

Most - Often - Needed

1959

Volume 19

**RADIO
DIAGRAMS**

and Servicing Information



Compiled by
M. N. BEITMAN

SUPREME PUBLICATIONS

RADIO DIAGRAM MANUALS

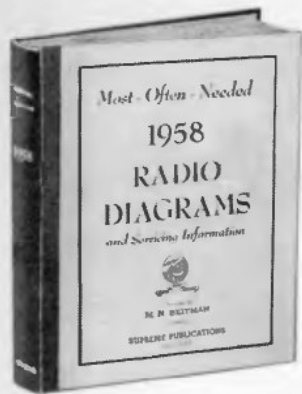

New 1958 **VOLUME 18**
Price \$2.50

Repair quickly all new 1958 sets as well as older radios. This big volume contains clearly printed, large schematics, needed alignment data, replacement parts lists, voltage values, and information on stage gain, location of trimmers, and dial stringing, for all important new 1958 sets. Includes material on portables, clock radios, record changers, FM, and auto sets. A worthy companion to seventeen previous volumes used by over 143,000 shrewd radio servicemen. Large size: 8½ x 11 inches. Manual style binding. **\$250**
Postpaid, only

RADIO DIAGRAMS FOR PREVIOUS YEARS

Speed up and simplify all radio repairs. Service radios faster, better, easier, save money and time, use these **SUPREME Most-Often-Needed** diagram manuals to get ahead. At the low cost (only \$2 for most volumes) you are assured of having for every job needed diagrams and other essential repair data on 4 out of 5 sets you will ever service. Clearly printed circuits, parts lists, alignment data, and helpful service hints are the facts you need. Average volume has 192 pages, large size 8½ x 11 inches. Manual style binding.

- | | | | | | |
|--|--|--|--|--|--|
| <input type="checkbox"/> 1957 Volume 17 \$2.50 | <input type="checkbox"/> 1956 Volume 16 \$2.50 | <input type="checkbox"/> 1955 Volume 15 \$2.00 | <input type="checkbox"/> 1954 Volume 14 \$2.50 | <input type="checkbox"/> 1953 Volume 13 \$2.50 | <input type="checkbox"/> 1952 Volume 12 \$2.50 |
| <input type="checkbox"/> 1951 Volume 11 \$2.50 | <input type="checkbox"/> 1950 Volume 10 \$2.50 | <input type="checkbox"/> 1949 Volume 9 \$2.50 | <input type="checkbox"/> 1948 Volume 8 \$2.00 | <input type="checkbox"/> 1947 Volume 7 \$2.00 | <input type="checkbox"/> 1946 Volume 6 \$2.00 |
| <input type="checkbox"/> 1942 Volume 5 \$2.00 | <input type="checkbox"/> 1941 Volume 4 \$2.00 | <input type="checkbox"/> 1940 Volume 3 \$2.00 | <input type="checkbox"/> 1939 Volume 2 \$2.00 | <input type="checkbox"/> 1926-1938 Volume 1 \$2.50 | |
- INDEX for all Radio and TV Manuals25¢

RADIO SERVICING COURSE



Here is your practical radio course of 22 easy-to-follow lessons. Review fundamentals, learn new servicing tricks. Just like a \$200.00 correspondence course. Everything in radio servicing. With self-testing questions. New edition. Price only **\$250**

Simplified Radio Servicing by COMPARISON Method

Revolutionary different **COMPARISON** technique permits you to do expert work on all radio sets. Most repairs can be made without test equipment or with only a volt-ohmmeter. Many simple, point-to-point, cross-reference, circuit suggestions locate the faults instantly. Plan copyrighted. Covers every radio set - new and old models. This new servicing technique presented in handy manual form, size 8½ x 11 inches, 92 pages. Over 1,000 practical service hints. 26 large, trouble-shooting blueprints. Charts for circuit analysis. 114 tests using a 5c resistor. Developed by M. N. Beitman. New edition. Price only..... **\$150**



How to Modernize Radios

Cash in by improving and modernizing all out of date radio sets and cabinets. Practical job-sheets with schematics and photographs make this work easy. Size 8½ x 11 inches. Your price only..... **\$1**



SUPREME TELEVISION MANUALS

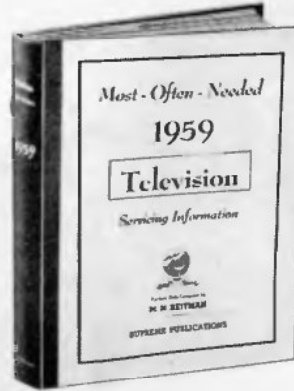

1959 TV Manual, TV-15

This new giant volume of 1959 television factory data will give you everything you need to repair and adjust all present-day TV sets. The **television series manual** are amazing bargains and defy competition. The 1959 volume contains circuit explanations, 192 pages of alignment facts, test patterns, response curves, waveforms, voltage charts, hints, and dozens of mammoth double-page work-bench diagrams. Large size 8½ x 11 inches. Sturdy covers. Book binding opens flat. Amazing value. Price postpaid, only. . . . **\$3**

EARLIER TV MANUALS FOR 1958 TO 1948

Supreme TV manuals cover all needed service material on every popular TV set of every important manufacturer. Here is helpful, practical, factory-prepared data that will really make TV servicing and adjustment easy for you. *Supreme* giant TV manuals have complete circuits, alignment facts, test patterns, response curves, service hints, recommended changes, voltage charts, waveforms, and many double-page diagram blueprints. Here is your TV service material to help you do more expert work quicker; and priced at only \$3. **Radio** manuals described at left.

- | | | | |
|---|---|--|---|
| <input type="checkbox"/> 1958 Television Manual, TV-14, \$3. | | | |
| <input type="checkbox"/> ADDITIONAL 1957 TV, Vol. TV-13, \$3. | | | |
| <input type="checkbox"/> EARLY 1957 TV Manual, TV-12, \$3. | | | |
| <input type="checkbox"/> 1956 TV Volume TV-11 \$3.00 | <input type="checkbox"/> 1955 TV Additional, TV-10 \$3.00 | <input type="checkbox"/> 1955 TV Early, Vol. TV-9 \$3.00 | <input type="checkbox"/> 1954 TV Volume TV-8 \$3.00 |
| <input type="checkbox"/> 1953 TV Volume TV-7 \$3.00 | <input type="checkbox"/> 1952 TV Volume TV-6 \$3.00 | <input type="checkbox"/> 1951 TV Volume TV-5 \$3.00 | <input type="checkbox"/> 1950 TV Volume TV-4 \$3.00 |
| <input type="checkbox"/> 1949 TV Volume TV-3 \$3.00 | <input type="checkbox"/> 1948 TV Volume TV-2 \$3.00 | <input type="checkbox"/> 1957-58 RCA Volume \$1.50 | |

TELEVISION SERVICING COURSE

Let this new course teach you TV servicing. Amazing bargain, complete only \$3, full price for all lessons. Giant in size, mammoth in scope, topics just like a \$200.00 correspondence course. Lessons on picture faults, circuits, adjustments, short-cuts, UHF, alignment hints, antenna problems, trouble-shooting, test equipment, picture analysis. Special, only **\$3**

RADIO MATHEMATICS

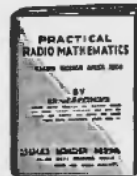

Explains arithmetic and simple algebra in connection with units, color code, meter scales, Ohm's law, alternating currents, ohmmeter testing, wattage rating, series and parallel connections, capacity, inductance, mixed circuits, vacuum tubes, curves, the decibel, etc., and has numerous examples. Only **25¢**

Practical Radio & Electronics Course

Here is your complete home study course of 35 lessons designed to train any beginner to be an expert in radio and electronics. Covers every topic of radio, electronics, with lessons on test equipment, FM, TV, radio, etc. Giant 8½ x 11 inches, 3-in-1 volume, includes all lessons, instructor's notes, test questions. New edition. Only. **\$395**

ANSWER BOOK to the above course.....25¢

Admiral

CHASSIS 6T2
MODELS 521 • 528

I. F. 455 KC.

TOTAL CURRENT DRAIN APPROXIMATELY
10.5 MA WITH VOLUME CONTROL AT MINIMUM
AND NO SIGNAL APPLIED.

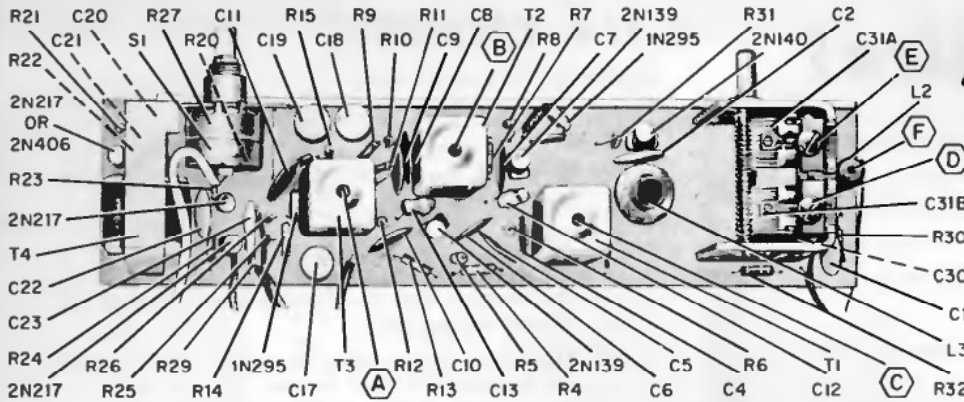

REMOVING THE CHASSIS

1. Remove **Tuning knob** and **Volume control knob** by working them forward and off the shaft.
2. Open cover on rear of cabinet.
3. Remove the battery case.
4. On the front of the cabinet, *loosen* the two Phillips head screws adjacent the tuning shaft.
5. *Loosen* the hex nut that secures the **Volume control** to front of case.
6. Hold the printed circuit board while removing the two screws and hex nut, to prevent damage.
7. Gently lift the circuit board from within cabinet.

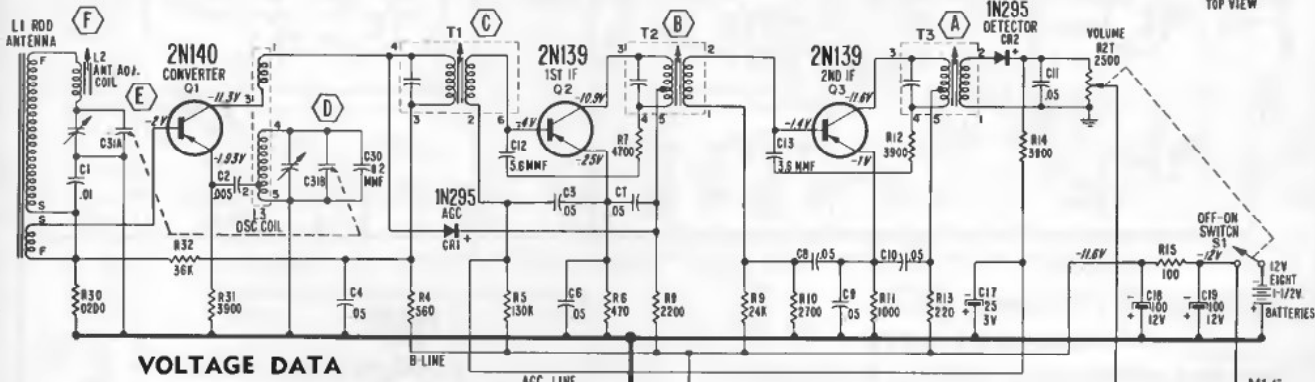
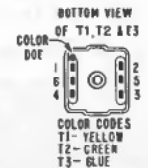

VOLTAGE DATA

DC voltages shown measured with no signal, using fresh batteries.

Volume control at minimum; dial set a low frequency end.

All readings made between transistor socket terminals and B plus (ground).

All voltage readings are negative.

- NOTES:
- IF-455K
 - CHASSIS GROUND
 - COMMON GROUND
 - * MATCHED PAIR
 - CAPACITOR VALUES IN MICROFARADS UNLESS OTHERWISE SPECIFIED
 - 1 NOT USED ON ALL CHASSIS.

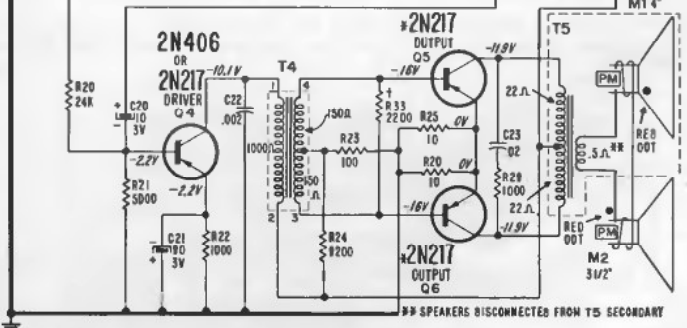
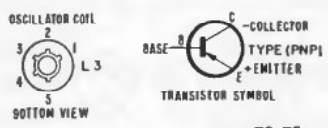

View of Printed Wiring Board. NOTE: Gray area represents printed wiring; black symbols and lines represent components and wiring on opposite side.

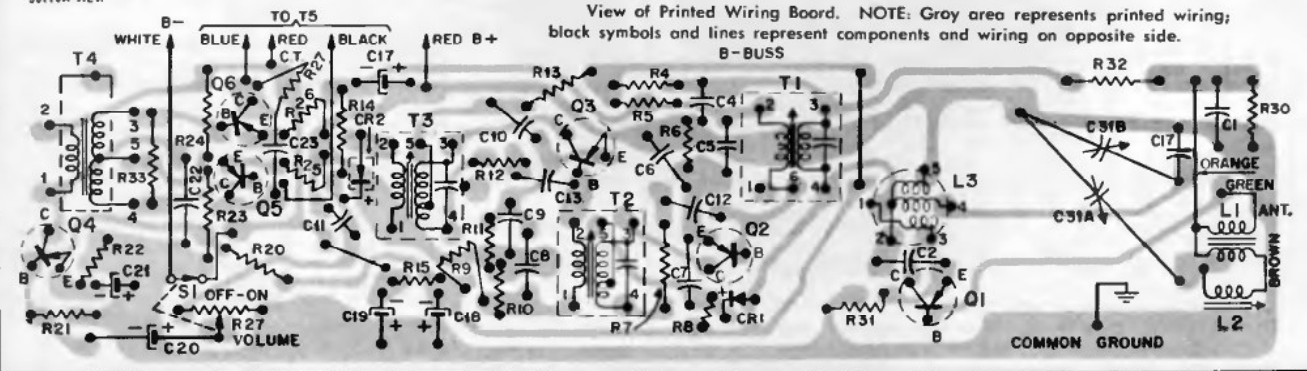

Admiral

CHASSIS 8M1 MODELS 801 • 802 • 808

REMOVING THE CHASSIS

To remove the cabinet front from the chassis, proceed as follows:

1. Remove the battery compartment cover.
2. Remove the batteries.
3. Remove the four Phillips head screws that are visible within the battery compartment.
4. The tuning knob hub is a thumb screw. Remove it by turning counterclockwise.
5. Remove tuning knob by working it forward and off the tuning shaft.

6. Remove the Phillips head screw at the left of the tuning shaft.

7. Gently lift the cabinet front from the cabinet back and chassis.

To remove chassis from cabinet back for servicing the wiring side of the chassis:

8. Make sure tuning gang is closed. Then remove the two Phillips head screws that are visible—one near the tuning capacitor and the other in lower left corner as radio is viewed from the front.
9. Lift speaker from cabinet and away from chassis.
10. Gently lift out wiring side of chassis from cabinet.

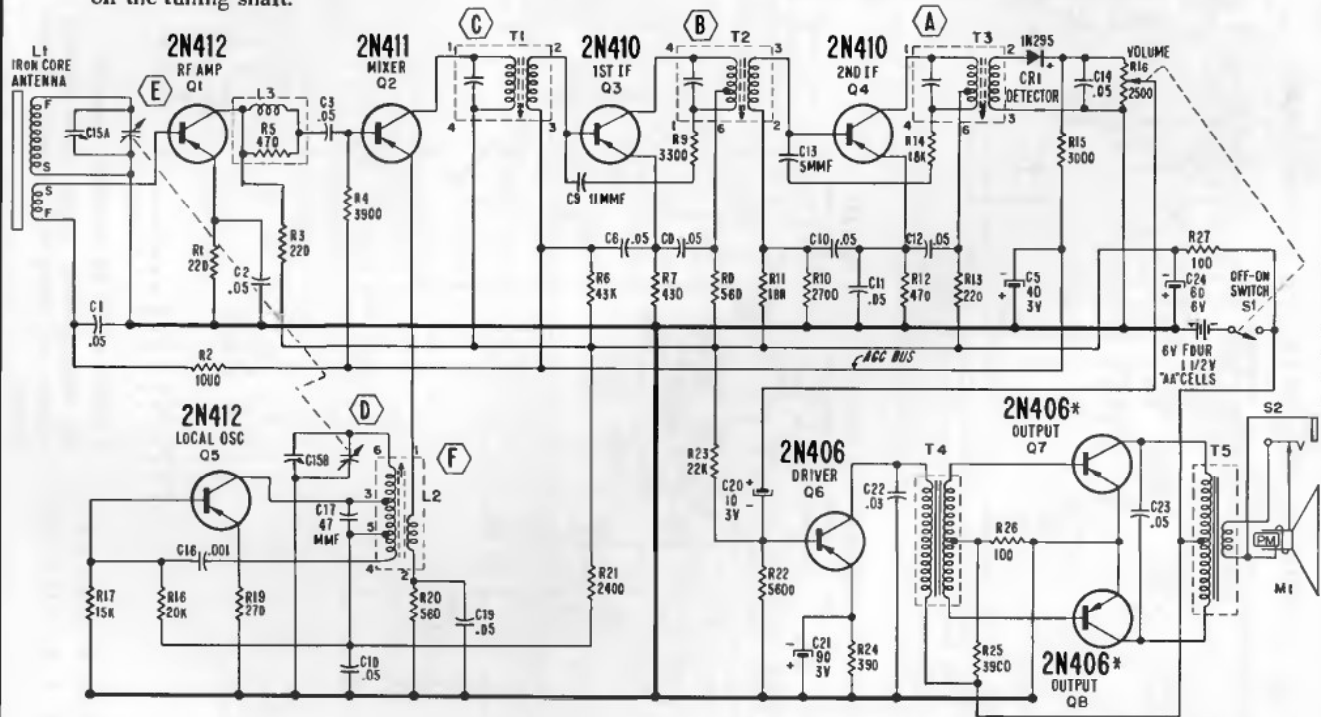

IF • 455 KC
 COMMON GROUND (B+)
 * MATCHED PAIR
 CAPACITOR VALUES IN MICROFARADS UNLESS OTHERWISE SPECIFIED.

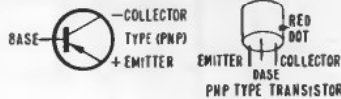

I. F. 455 KC.

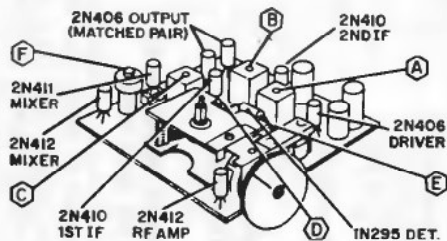

Transistor and Alignment Locations

VOLTAGE DATA

Voltages shown measured with no signal, using fresh batteries. Volume control at minimum; dial set at low frequency end. All readings made with VTVM between transistor terminals and B plus (ground). All voltages are negative.

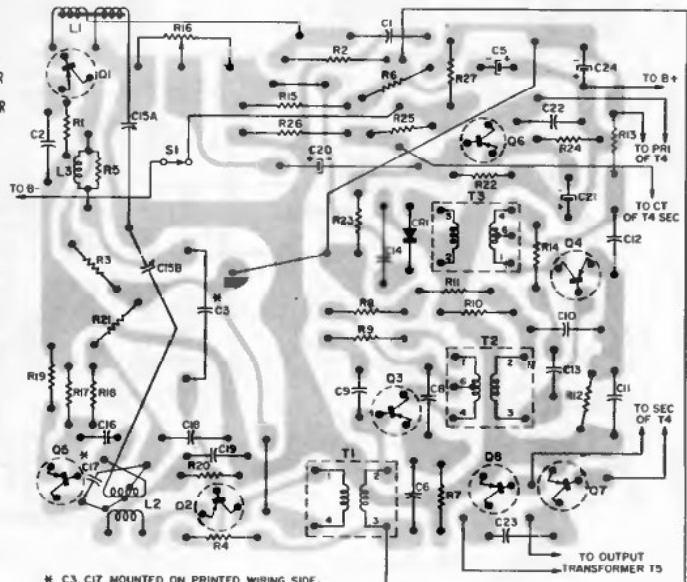

* C3, C17 MOUNTED ON PRINTED WIRING SIDE.

View of Printed Wiring Board. Gray area represents printed wiring, black symbols and lines represent components.

Admiral

Models 392 and 393, use
7N1 Tuner & 4S2 Amplifier;
Models 462 and 463, use
7N1A Tuner & 4S2 Amplifier.

(Schematic of 7N1A Tuner on
this page, balance of material
on page 7.)

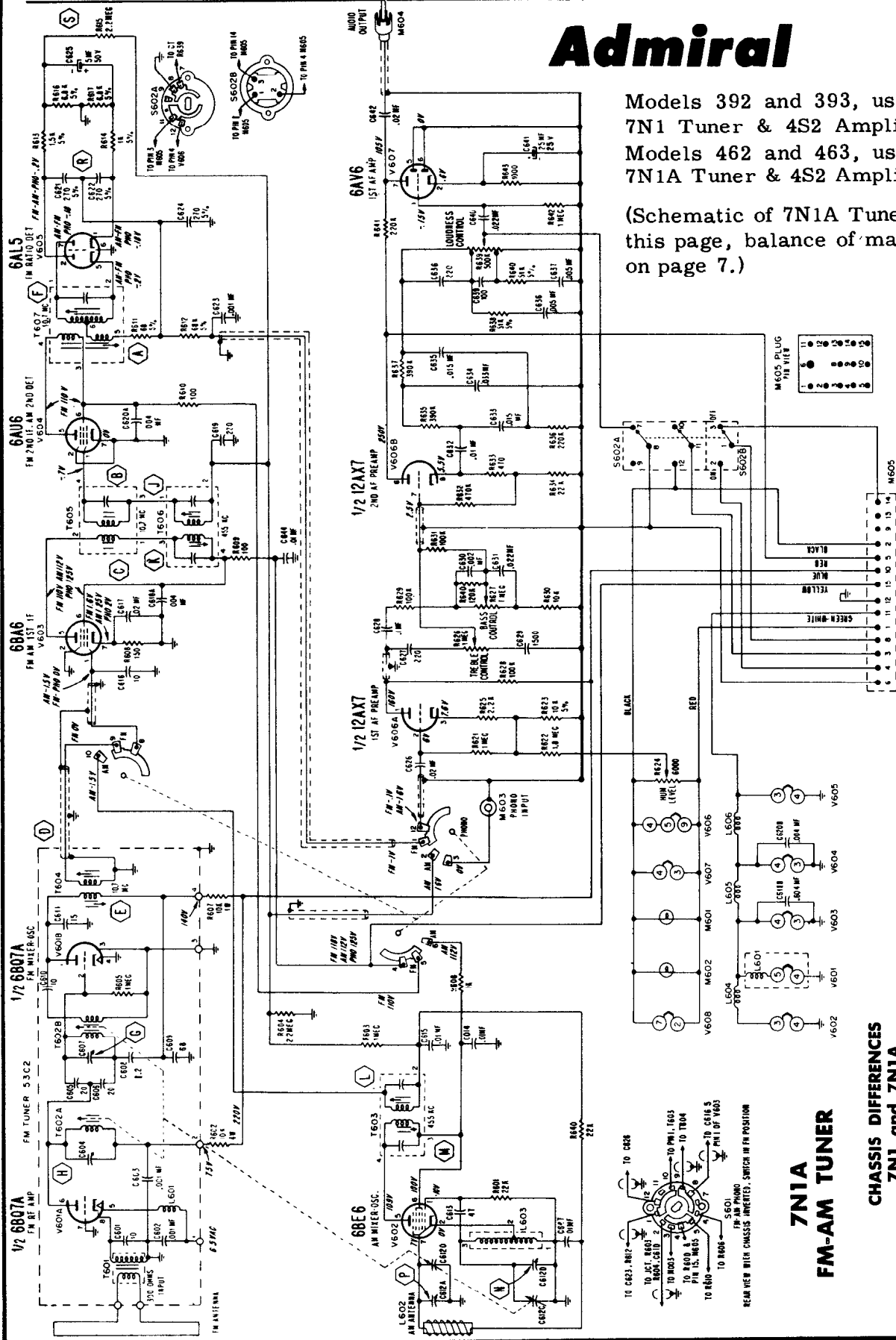

Volts shown on schematic diagram.
All measurements, except some filament
voltages, are taken with respect to chassis
ground.

A. M. I. F. 455 KC.
F. M. I. F. 10.7 MC.

CHASSIS DIFFERENCES 7N1 and 7N1A

The 7N1A FM-AM Tuner is similar to the 7N1
FM-AM Tuner covered in S810. The 7N1A has a
new AM converter circuit. All 7N1A chassis are
mounted in the inverted position in the cabinet.

7N1A FM-AM TUNER

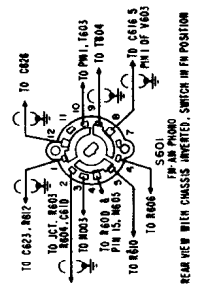

Admiral

Models 392, 393, 462, and 463.

7N1 and 7N1A AM-FM TUNERS and 4S2 HI-FI AMPLIFIER

(Continued from page 6)

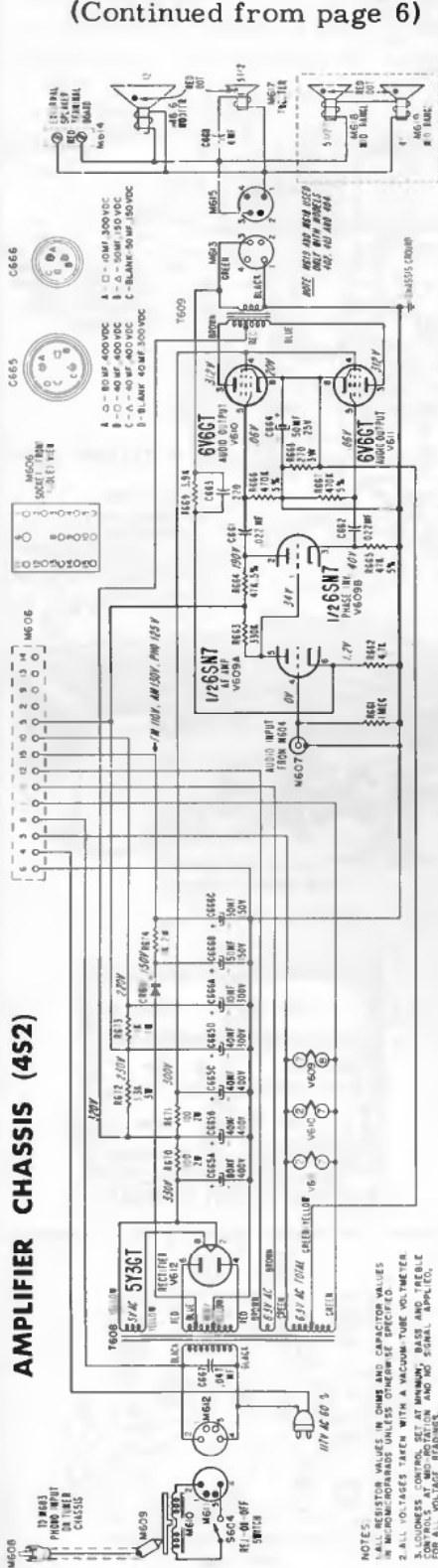

AMPLIFIER CHASSIS (4S2)

4S2B

- NOTES:
1. ALL RESISTOR VALUES IN OHMS UNLESS OTHERWISE SPECIFIED.
 2. ALL VOLTAGES TAKEN WITH A VACUUM TUBE VOLTMETER.
 3. LOUDNESS CONTROL SET AT MAXIMUM, BASS AND TREBLE CONTROLS AT MID POSITION, AND NO SIGNAL APPLIED.
 4. AMPLIFIER AND TUNER CONNECTED FOR ALL VOLTAGE READINGS.

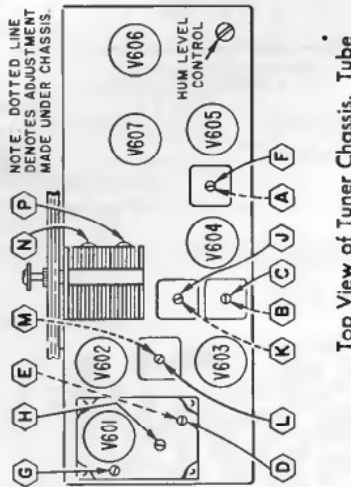
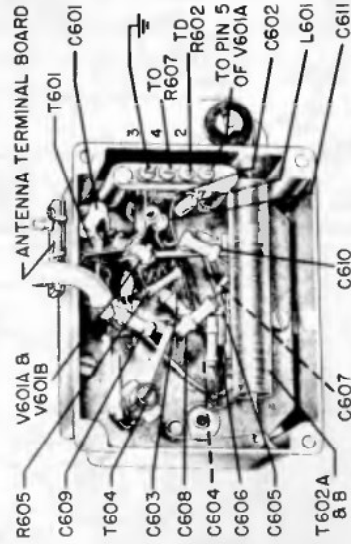

Bottom View of FM Tuner Sub-chassis. Location of components shown.

Top View of Tuner Chassis. Tube locations and alignment points shown.

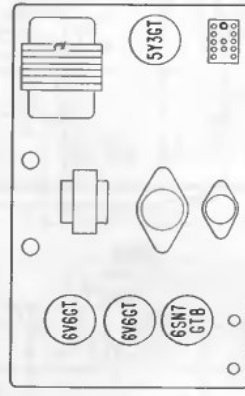

Top View of Amplifier Chassis. Tube locations shown.

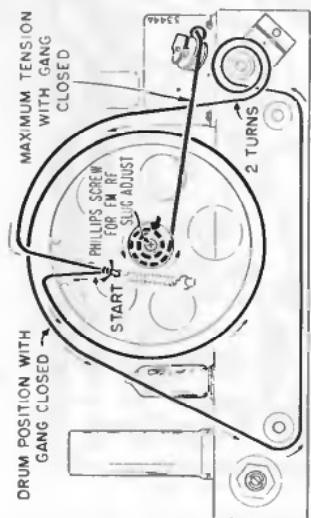

Dial Stringing (Early Production).

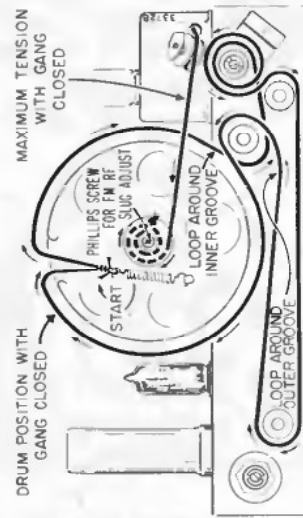

Dial Stringing (Present Production).

Dial Stringing (Chassis 7N1A).

Material applicable to 7N1 and 7N1A Tuners and 4S2 Amplifier.

Admiral

Chassis 8S1, Models 561, 566, exact material.
Chassis 8S1A, Models 811, 816, include clock.

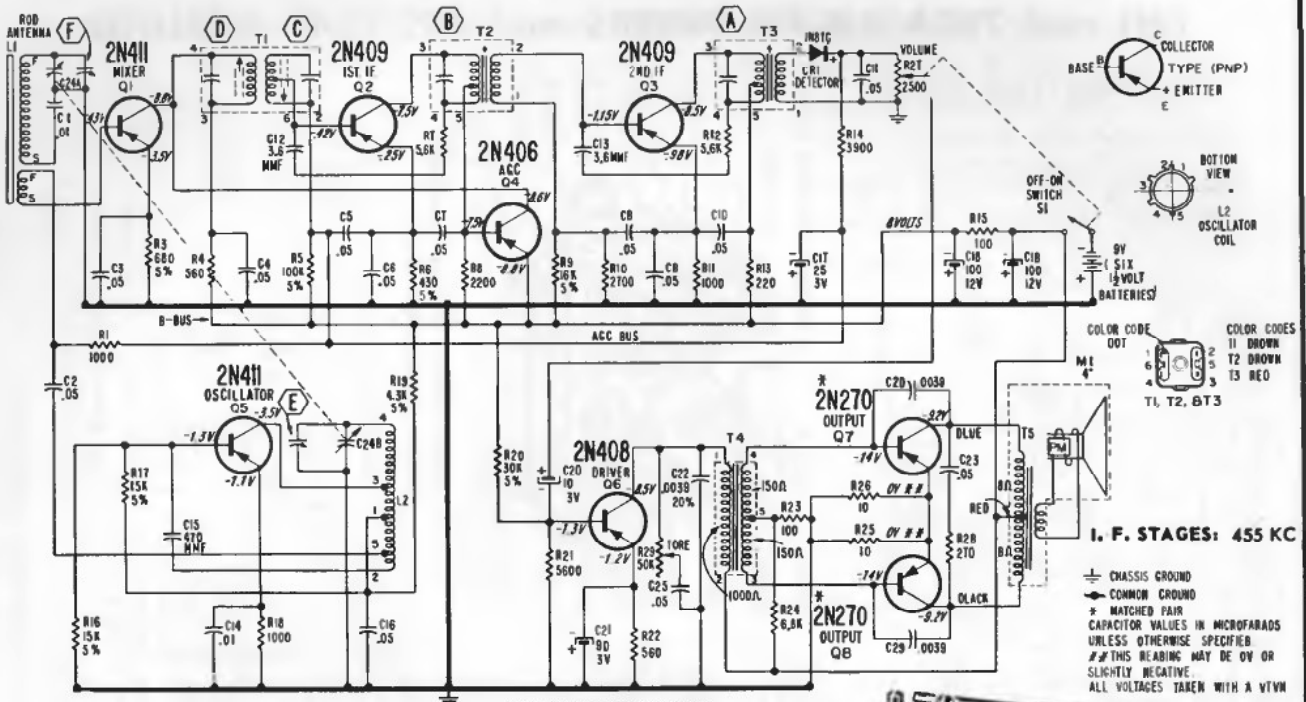

REMOVING CHASSIS

TOTAL CURRENT DRAIN WITH NO SIGNAL AND VOLUME CONTROL SET AT MINIMUM-8.5 MA

1. Remove 2 screws near front edge of cabinet bottom.
2. Remove 2 screws from upper section of cabinet back.
3. Pull chassis and front panel free of cabinet.

The speaker, volume and tone control, and printed chassis board are all fastened separately with screws to the front panel. Remove them individually as required by removing their mounting screws.

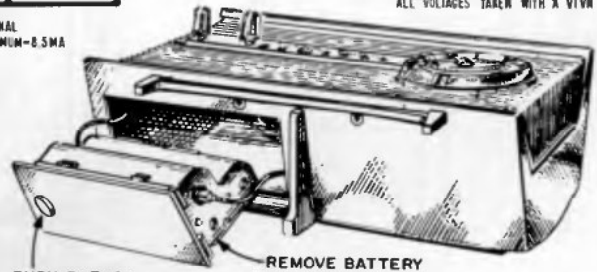

PUSH BUTTON

REMOVE BATTERY CASE FROM CABINET

Removing Battery Case.

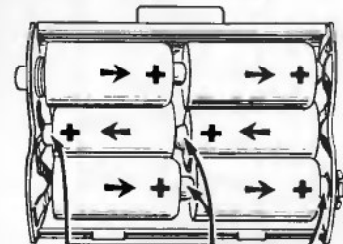

CENTER CAPS (POSITIVE TERMINALS(+))

Battery Case Showing Batteries in Correct Position.

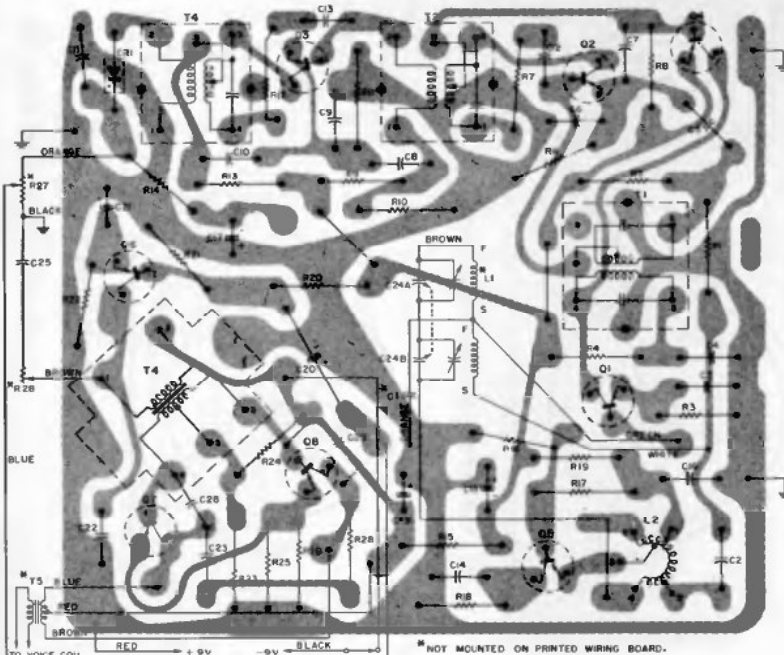

View of Printed Wiring Board. Gray area represents printed wiring, black symbols and lines represent components.

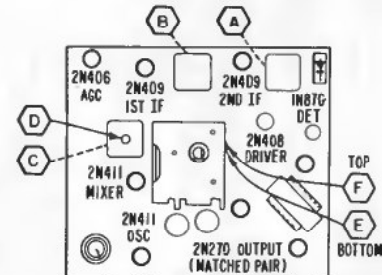

NOTE: DOTTED LINES INDICATE ADJUSTMENT UNDER BOARD
Transistor and Alignment Locations.

I. F. STAGES: 455 KC

CHASSIS GROUND
 COMMON GROUND
 * MATCHED PAIR
 CAPACITOR VALUES IN MICROFARADS UNLESS OTHERWISE SPECIFIED
 # THIS READING MAY BE 0V OR SLIGHTLY NEGATIVE.
 ALL VOLTAGES TAKEN WITH A VTVM

Admiral 12B1-12B1A-5T4A CHASSIS

Models 632, 633, 634, 642, 643, 644, 649, 654, 662, 663, 664, 671, use Chassis 12B1. Chassis 12B1A has a different panel; used in later Model 649. Same model numbers with prefix SS use auxiliary stereo unit 5T4A.

(Additional material on pages 10-11)

Run changes refer to 12B1 schematic diagram on next two pages.

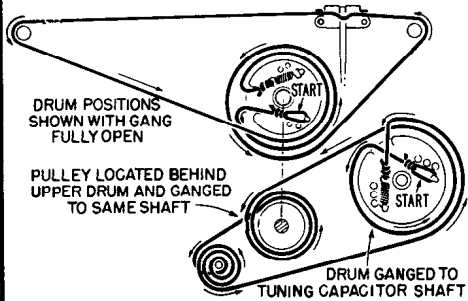

Stringing Diagram. (Early Production)

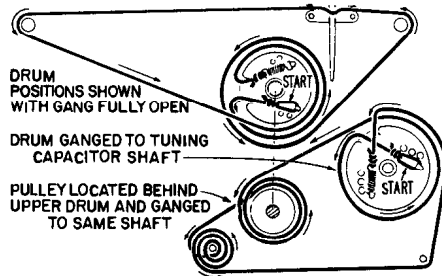

Stringing Diagram.

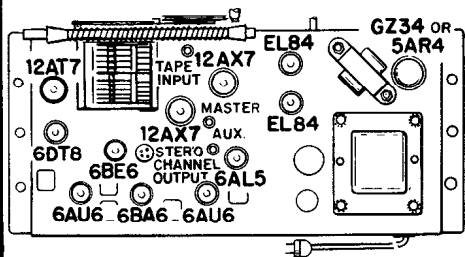

Top View of 12B1 Chassis, Tube Locations Shown.

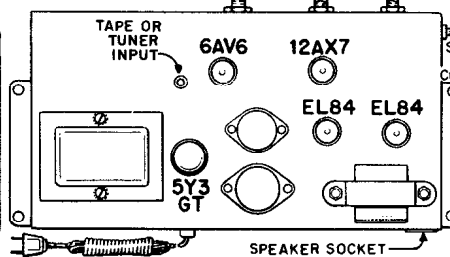

Top View of 5T4A Chassis

- 10 Start of production 12B1.
- 11 R25 (15K, 1W) changed to (22K, 1W) to permit full interchangeability 6BE6 tubes. R33 changed to (390K, 1/2W); R34 to (100K, 1/2W); and C39 to (.002MF) to improve AM operation. R70 (470K, 1/2W) added between M11 and M12 to minimize rumble.
- 12 R70 (470K, 1/2W) removed to increase channel separation for stereo operation.
- 13 To insure proper operation of OFF-ON-POWER relay at low line voltages, R45 (33K, 2W) removed and R71 (33K, 2W) added in its place.
- 14 To reduce possibility of regeneration in strong signal areas, C18 (.02MF) and C21 (.02MF) removed. R72 (75K 5%) and R73 (75K, 5%) added to 1F section. R65 (160K) connected to B + 200V. For standardization of parts, C19A and B (dual .004MF; V2 screen and filament bypass) removed. C18 (.01MF) V2 screen bypass and C72 (.005MF) V2 filament bypass added. C22A and B (dual .004MF; V3 screen and filament bypass) removed. C22 (.01MF) V3 screen bypass and C73 (.005MF) V3 filament bypass added. C24A and B (dual .004MF; V4 screen and filament bypass) removed. C24 (.01MF) V4 screen bypass and C74 (.005MF) V4 filament bypass added. VB changed to ECC83. For improved frequency response, C55 changed to .02MF. C64 changed to .02MF. C66 and C67 each changed to .022MF. C75 (.001MF) added from plate to screen of V12. To increase AM audio output, R33 changed to 100K and R34 changed to 390K. R74 (100K, 1W) added.
- 15 R75 (10 ohms, 1/2 watt) added between pin 2 of V1B and R2 to reduce possibility of RF regeneration.

Schematic of 5T4A Amplifier Chassis Stamped Run 10.

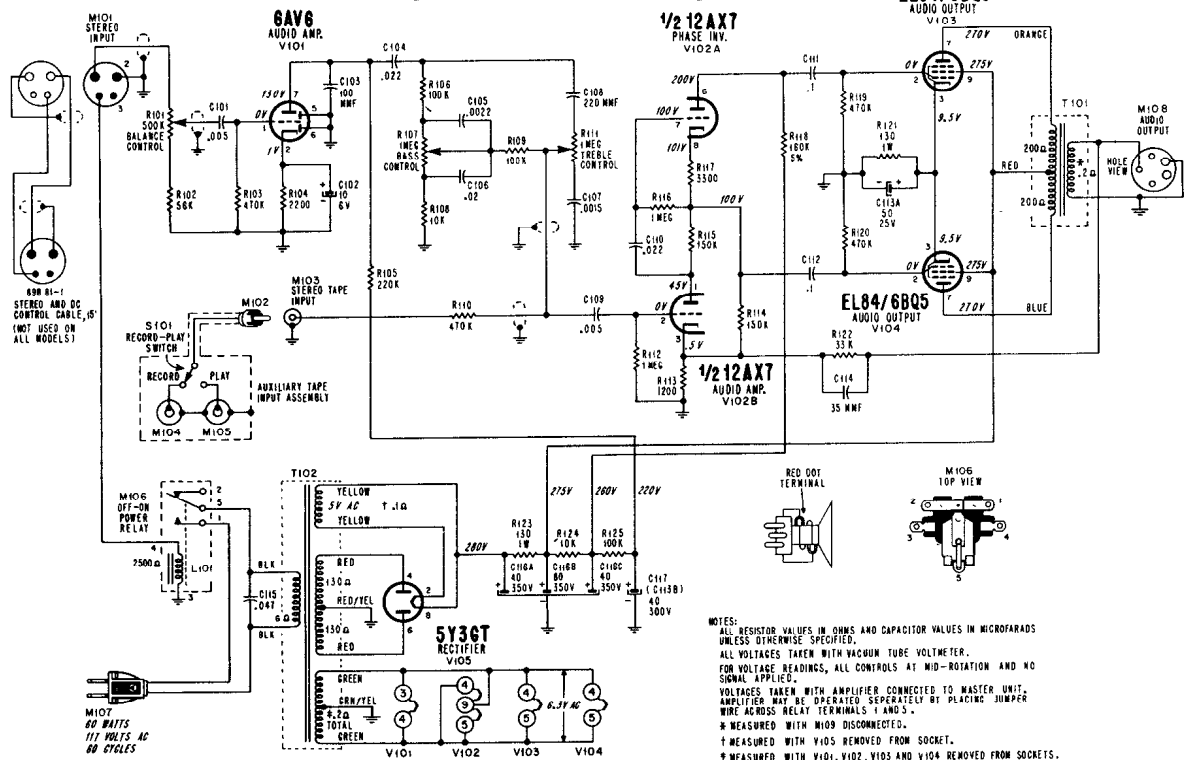

ADMIRAL Schematic diagram of 12B1, 12B1A, Run 15, Continued

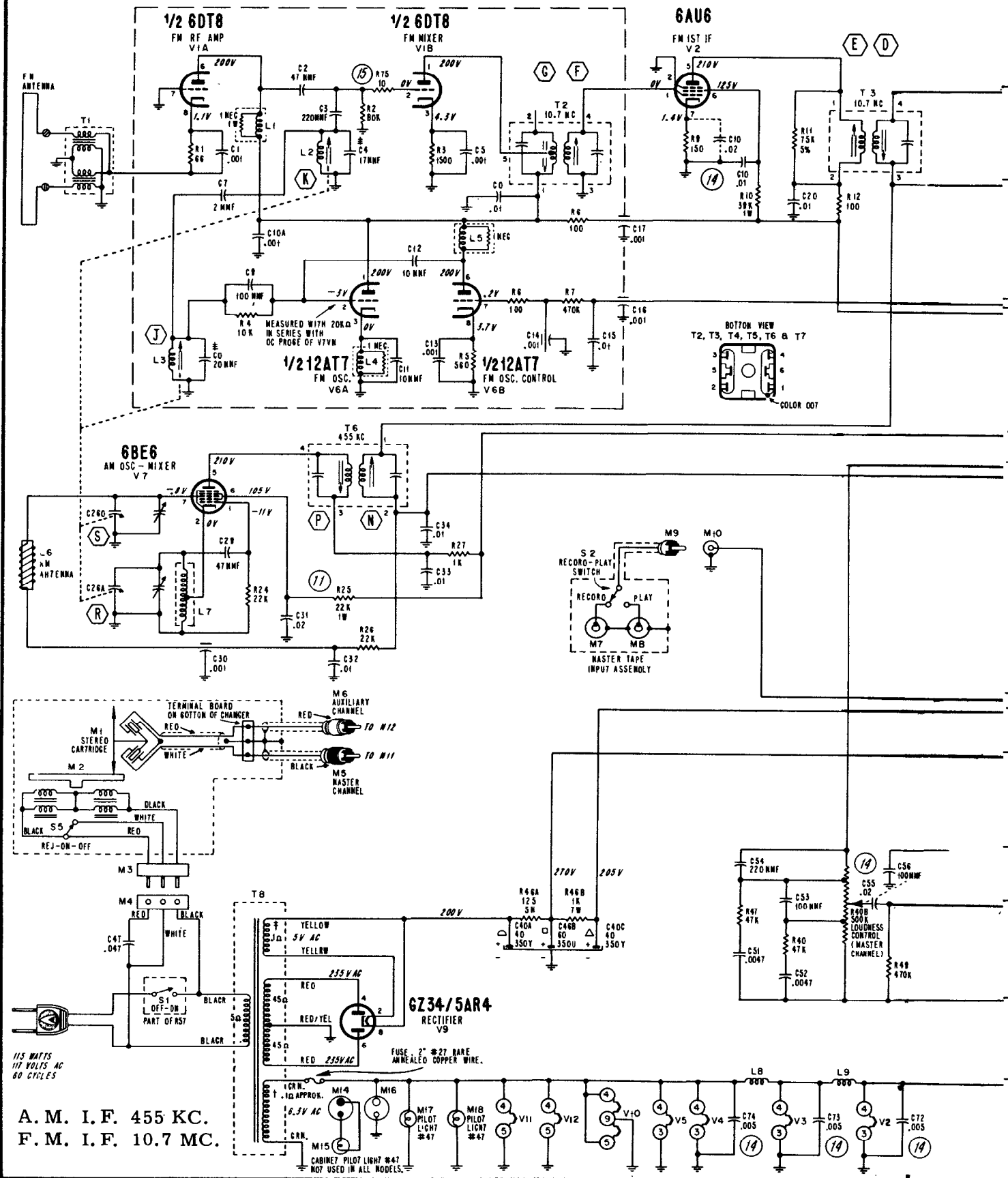

A. M. I. F. 455 KC.
F. M. I. F. 10.7 MC.

VOLUME R-19, MOST-OFTEN-NEEDED 1959 RADIO SERVICING INFORMATION

ADMIRAL Schematic Diagram of 12B1-12B1A Radio Chassis Stamped Runs 10 through 15.

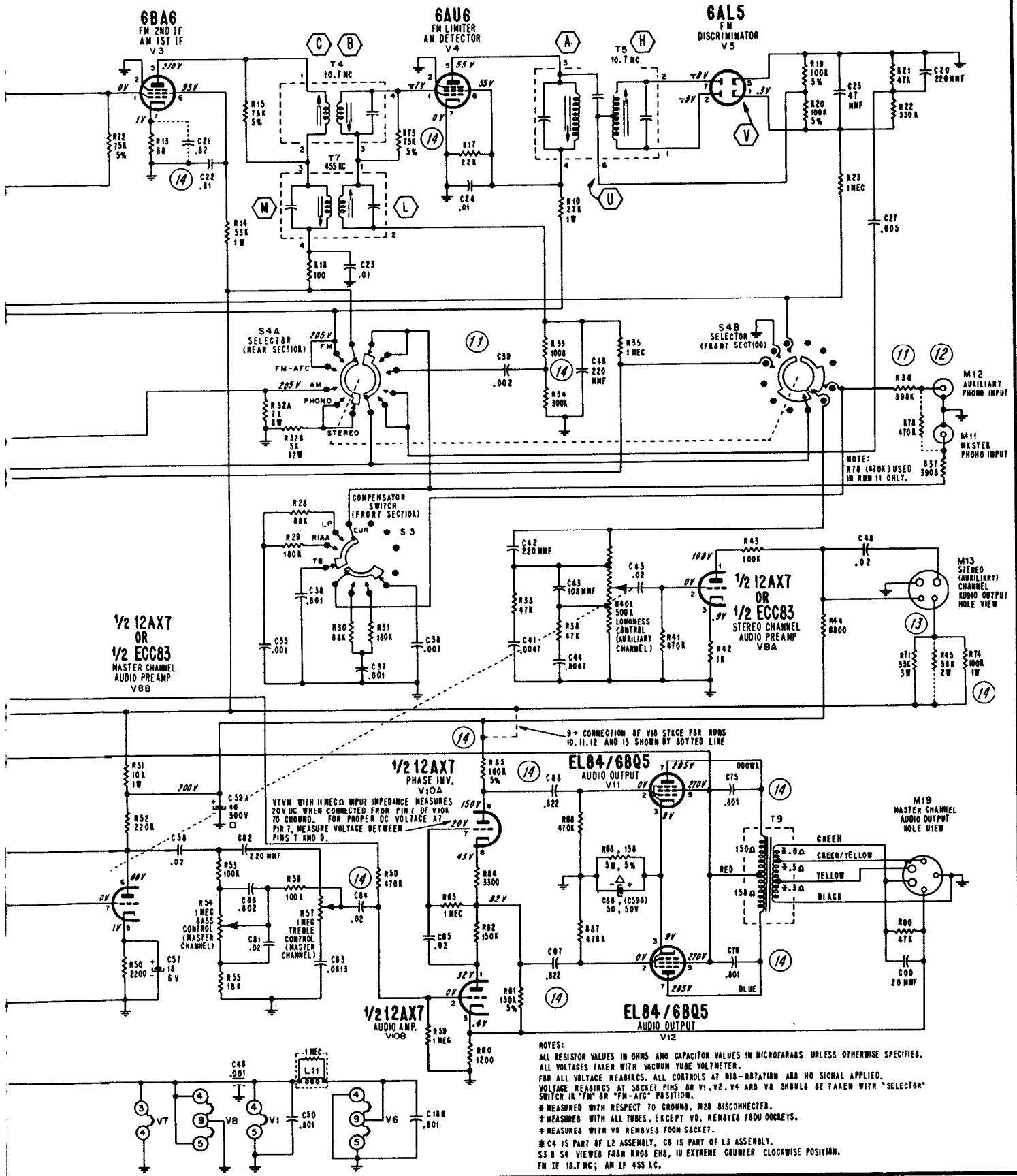

MOST-OFTEN-NEEDED 1959 RADIO SERVICING INFORMATION

ARVIN
 Model 2581
 Chassis 1.43800

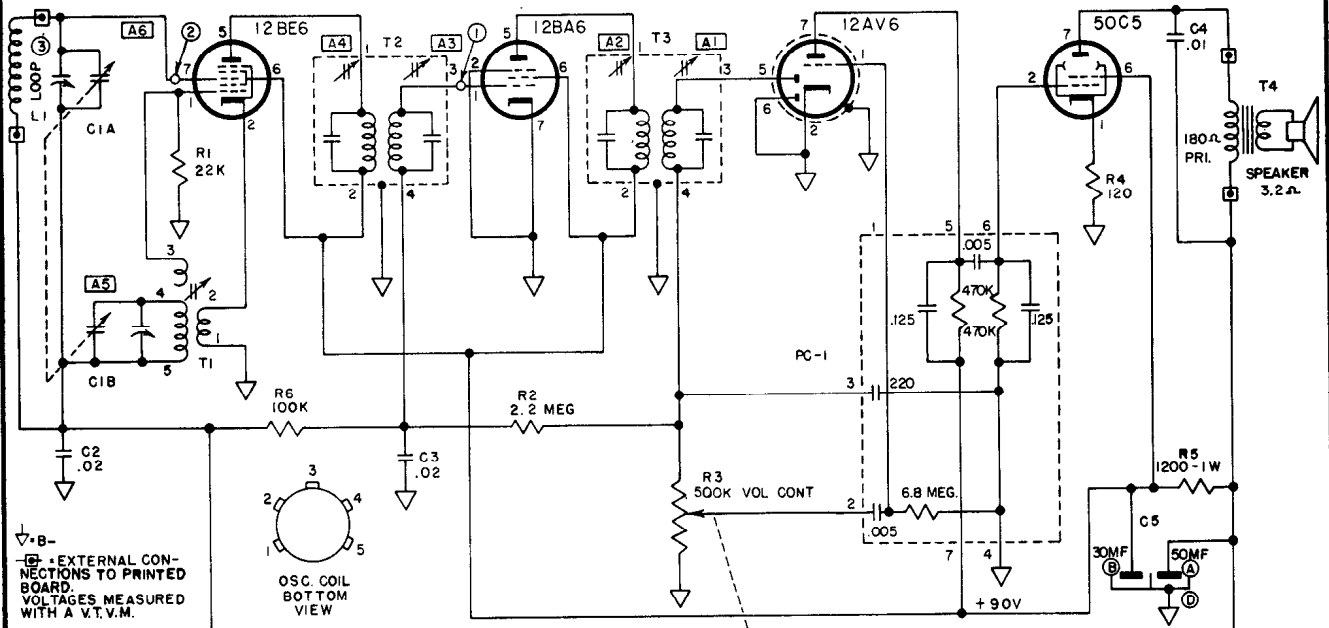
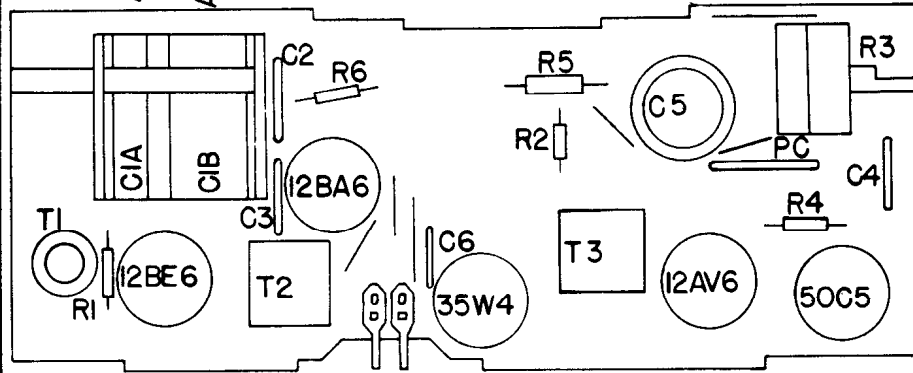

EXTERNAL CONNECTIONS TO PRINTED BOARD. VOLTAGES MEASURED WITH A V.T.V.M.

RESISTANCE VALUES ARE IN OHMS K=1,000, MEG=1,000,000. CAPACITANCE VALUES LESS THAN (1) ARE IN MICROFARADS (μF), AND VALUES OF (1) OR GREATER ARE IN MICROMICROFARADS (μμF), UNLESS OTHERWISE INDICATED.

APPROXIMATE SENSITIVITIES

| CIRCUIT POINT | DUMMY TO GENERATOR | INPUT FOR .05 WATT OUTPUT (0.4 VOLTS ACROSS VC) | INPUT FOR .5 WATT OUTPUT (1.26 VOLTS ACROSS VC) |
|---------------|--------------------------|---|---|
| 1 | 05 μF AT 455 KC | 2000 UV | 5000 UV |
| 2 | 05 μF AT 455 KC | 60 | 150 |
| 3 | STANDARD LOOP AT 1000 KC | 200 UV/M | 500 UV/M |

ALIGNMENT PROCEDURE Output meter connection Across speaker voice coil
 Output meter reading to indicate 500 milliwatts (standard output)... 1.26 volts
 Connection of generator ground lead..... Floating ground
 Generator modulation 30% 400 cycles

| Position of Variable | Frequency of Generator | Dummy Antenna | Generator Output Connection | Trimners Adjusted in Order Shown for Maximum Output | Function of Trimmer |
|----------------------|------------------------|---------------|-----------------------------|---|---------------------|
| Open | 455 Kc | .05 μ fd | Pin 7 12BE6 | A1, A2, A3, A4 | I. F. |
| Open | 1670 Kc | | * Test Loop | A5 | Oscillator |
| 1400 | 1400 Kc | | * Test Loop | A6 | Antenna |
| 1000 | 1000 Kc | | * Test Loop | Fan C1A Plates | |
| 600 | 600 Kc | | * Test Loop | Fan C1A Plates | |

* Standard Hazeltine Test Loop Model 1150 or 3 turns of wire about 6" in diameter placed about one foot from the set loop.

VOLUME R-19, MOST-OFTEN-NEEDED 1959 RADIO SERVICING INFORMATION

ARVIN Industries
 Model 3588
 Chassis 1.45200

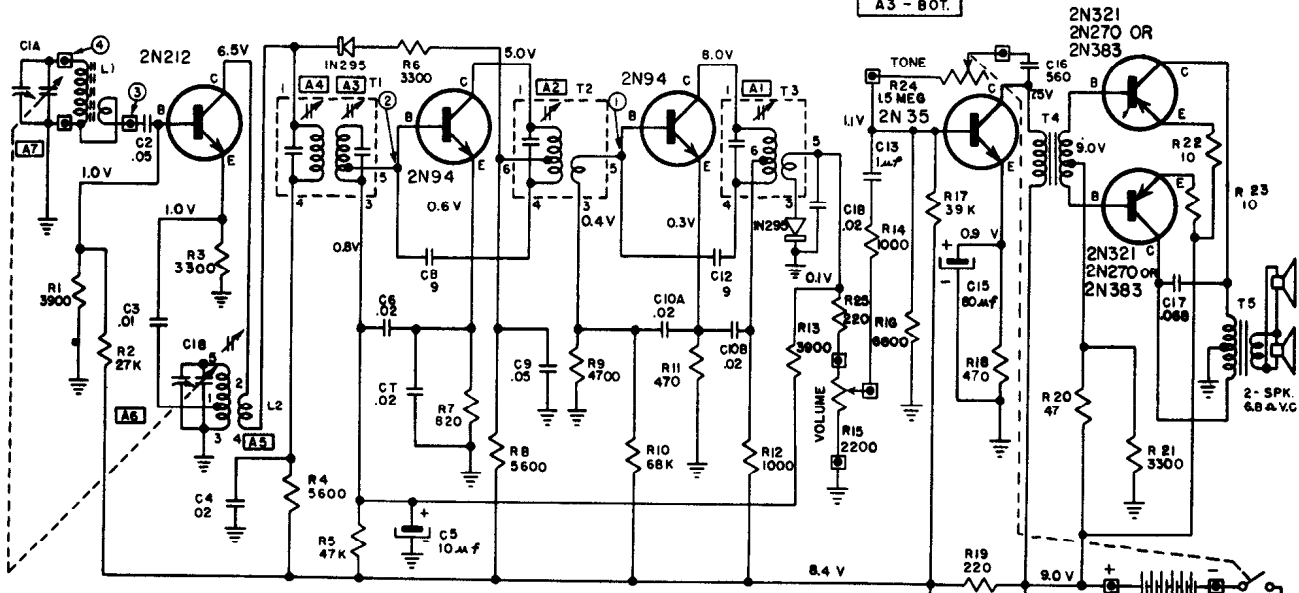
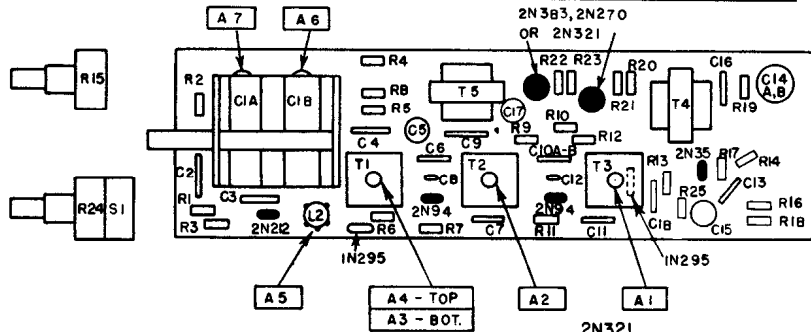

RESISTANCE VALUES ARE IN OHMS; K = 1000.
 CAPACITANCE VALUES LESS THAN 1.0 ARE IN MICROFARADS (μmf) AND VALUES GREATER THAN 1.0 ARE IN MICRO-MICROFARADS (μmf) EXCEPT WHERE NOTED.
 VOLTAGE READINGS TO COMMON GROUND ARE MEASURED WITH VACUUM TUBE VOLT-METER UNDER NO SIGNAL CONDITIONS WITH TUNING CAPACITOR CLOSED AND VOLUME CONTROL AT MAXIMUM CLOCKWISE ROTATION.

| SIGNAL TEST POINT | TEST FREQUENCY | SERIES CAPACITOR TO GENERATOR | INPUT FOR .05 WATT OUTPUT (0.4 V ACROSS 3.2 Ω) |
|-------------------|----------------|-------------------------------|--|
| ① | 455 KC | .05 μf | 2000 μV |
| ② | 455 KC | .05 μf | 65 μV |
| ③ | 455 KC | .05 μf | 5 μV |
| ④ | 1000 | STANDARD LOOP | 150 $\mu\text{V}/\text{M}$ |

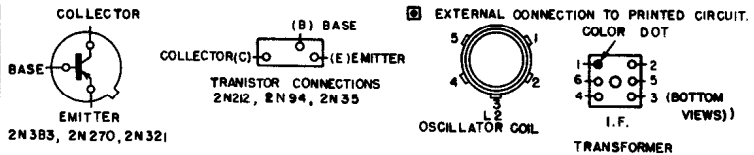

ALIGNMENT PROCEDURE

- Output meter reading to indicate 50 milliwatts 0.4V
- Output meter connection..... Across speaker voice coil
- Connection of generator ground lead..... Common Ground
- Generator Modulation..... 30% 400 cycles
- Position of volume control..... Fully clockwise

| Position of Variable | Generator Frequency | Dummy Antenna | Generator Connections | Trimmers Adj. in order shown for Max. Output | Function of Trimmer |
|----------------------|---------------------|-------------------|-----------------------|---|----------------------------------|
| Open | 455 Kc | .05 μf | C1A | A1 (Top of T3) A2 (Top of T2) A3 (Bottom of T1) A4 (Top of T1) | I. F. I. F. I. F. I. F. |
| Open | 1670 Kc | | *Test Loop | A6 | Oscillator |
| 1400 Kc | 1400 Kc | | *Test Loop | A7 | Antenna |
| 600 Kc | 600 Kc | | *Test Loop | Check Point | |

*Standard Hazeltine Test Loop Model 1150 or 3 turns of wire about 6" in diameter placed about one foot from the set loop.

VOLUME R-19, MOST-OFTEN-NEEDED 1959 RADIO SERVICING INFORMATION

ARVIN Industries
Model 5583, Chassis 1.44200
Model 2584, Chassis 1.44100
 differs from this material by
 not using a clock timer and in
 employing two speakers.

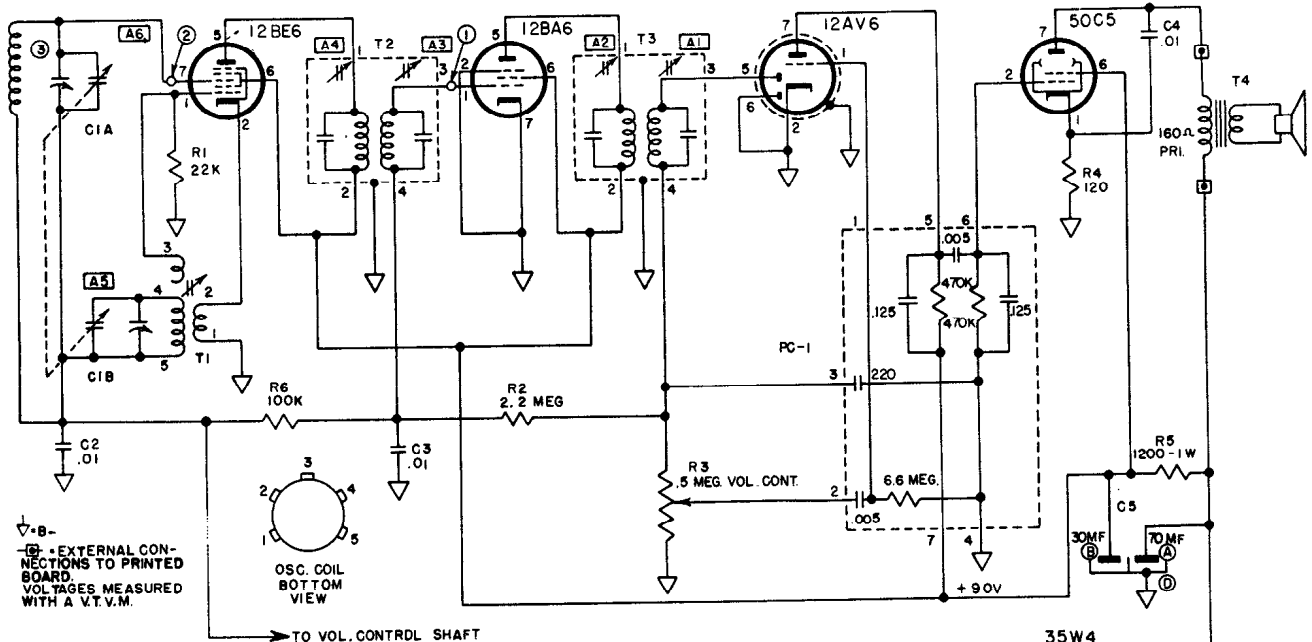
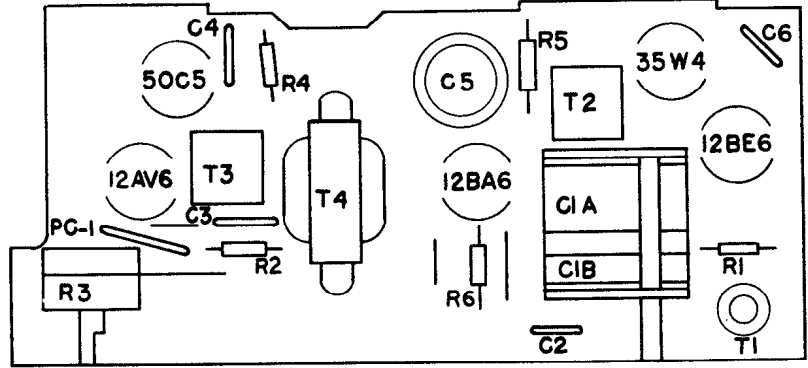

▽B-
 [Symbol] - EXTERNAL CON-
 NECTIONS TO PRINTED
 BOARD.
 VOLTAGES MEASURED
 WITH A V.T.V.M.

RESISTANCE VALUES ARE IN OHMS K=1,000, MEG=1,000,000.
 CAPACITANCE VALUES LESS THAN (1) ARE IN MICROFARADS (μF),
 AND VALUES OF (1) OR GREATER ARE IN MICROMICROFARADS
 (μμF), UNLESS OTHERWISE INDICATED.

APPROXIMATE SENSITIVITIES

| CIRCUIT POINT | DUMMY TD GENERATOR | INPUT FOR 0.5 WATT OUTPUT (0.4 VOLTS ACROSS VC) | INPUT FOR 5 WATT OUTPUT (1.26 VOLTS ACROSS VC) |
|---------------|--------------------------|---|--|
| 1 | .05 μF AT 455 KC | 2000 UV | 5000 UV |
| 2 | 05 μF AT 455 KC | 60 | 150 |
| 3 | STANDARD LOOP AT 1000 KC | 200 UV/M | 500 UV/M |

ALIGNMENT PROCEDURE Output meter connection Across speaker voice coil
 Output meter reading to indicate 500 milliwatts (standard output)... 1.26 volts
 Connection of generator ground lead Floating ground
 Generator modulation 30% 400 cycles

| Position of Variable | Frequency of Generator | Dummy Antenna | Generator Output Connection | Trimmers Adjusted in Order Shown for Maximum Output | Function of Trimmer |
|----------------------|------------------------|---------------|-----------------------------|---|--------------------------|
| Open | 455 Kc | .05 μ fd | Pin 7 12BE6 | A1, A2, A3, A4 | I. F. Oscillator Antenna |
| Open | 1670 Kc | | * Test Loop | A5 | |
| 1400 | 1400 Kc | | * Test Loop | A6 | |
| 1000 | 1000 Kc | | * Test Loop | Fan C1A Plates | |
| 600 | 600 Kc | | * Test Loop | Fan C1A Plates | |

* Standard Hazeltine Test Loop Model 1150 or 3 turns of wire about 6" in dia-
 meter placed about one foot from the set loop.

VOLUME R-19, MOST-OFTEN-NEEDED 1959 RADIO SERVICING INFORMATION

ARVIN Industries

Model 8584, Chassis 1.44600

| SIGNAL TEST POINT | TEST FREQUENCY | SERIES CAPACITOR TO GENERATOR | INPUT FOR .05 WATT OUTPUT (0.4 V ACROSS 3.2A) |
|-------------------|----------------|-------------------------------|---|
| ① | 455 KC | .05 μ f | 5000 μ V |
| ② | 455 KC | .05 μ f | 200 μ V |
| ③ | 455 KC | .05 μ f | 8 μ V |
| ④ | 1000 KC | STANDARD LOOP | 250 μ V/M |

ALIGNMENT PROCEDURE

Output meter reading to indicate 50 milliwatts 0.4V
 Output meter connection Across speaker voice coil
 Connection of generator ground lead Common Ground
 Generator Modulation 30% 400 Cycles
 Position of volume control Fully Clockwise

| Position of Variable | Generator Frequency | Dummy Antenna | Generator Connections | Trimmers Adj. in order shown for Max. Output | Function of Trimmer |
|----------------------|---------------------|---------------|-----------------------|--|---------------------|
| Open | 455 Kc | .05 μ f | C1A | A1 (Top of T3) A2 (Top of T2) A3 (Top of T1) | I. F. |
| Open | 1670 Kc | | *Test Loop | A4 | I. F. |
| 1400 Kc | 1400 Kc | | *Test Loop | A6 | Oscillator |
| 600 Kc | 600 Kc | | *Test Loop | Check Point | Antenna |

*Standard Hazeltine Test Loop Model 1150 or 3 turns of wire about 6" in diameter placed about one foot from the set loop.

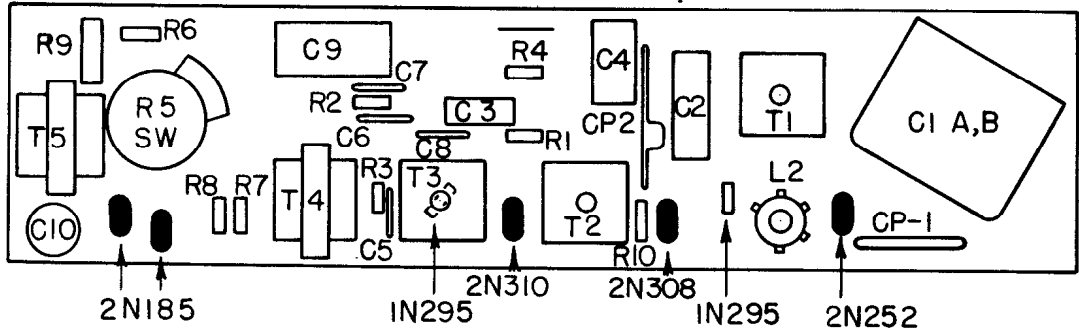
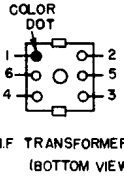
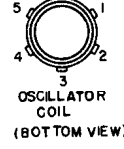
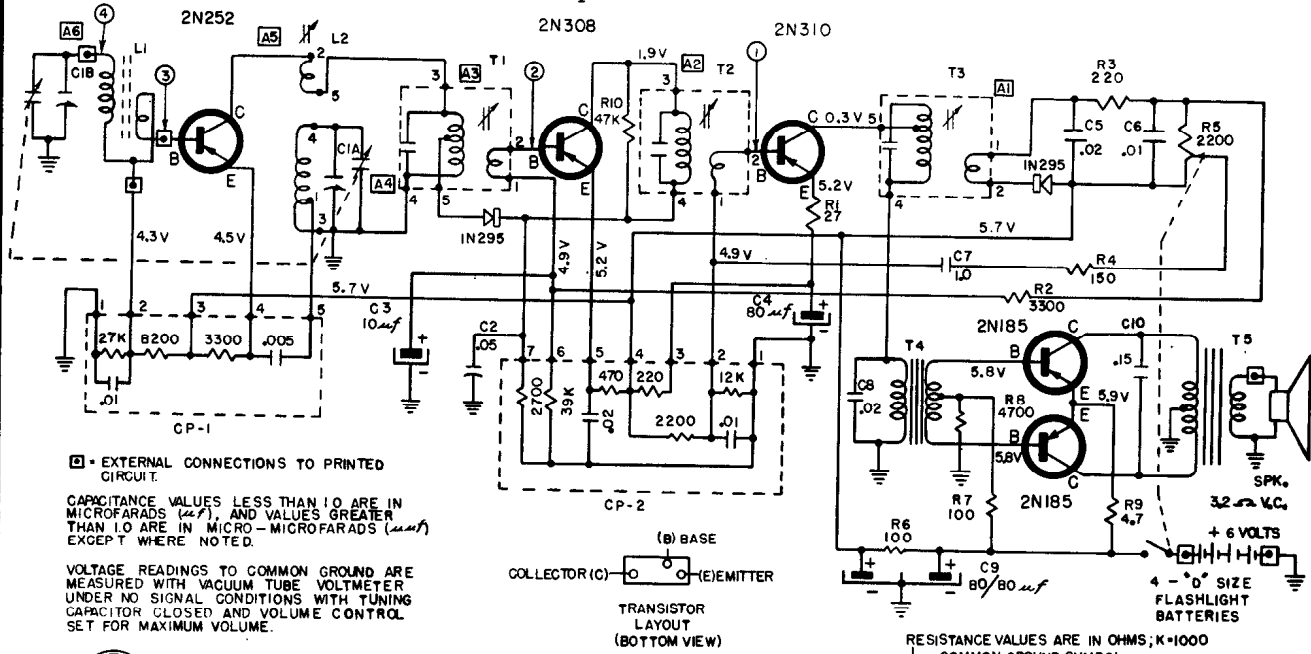

VOLUME R-19, MOST-OFTEN-NEEDED 1959 RADIO SERVICING INFORMATION

ARVIN Industries, Models 8581, 8583, Chassis 1.43700, 1.43900

ALIGNMENT PROCEDURE

Output meter reading to indicate .05 watt across voice coil..... 0.4V
 Generator ground lead connected..... floating ground
 Generator modulation..... 30% 400 cycles
 Position of Volume Control fully on

| Position of Variable | Generator Frequency | Dummy Antenna | Generator Connections | Adjust Trimmers (In order shown) | Function of Trimmer |
|----------------------|---------------------|---------------|-----------------------|----------------------------------|---------------------|
| Open | 455 Kc | .05 μ f | Mixer Grid | A1, A2, A3, | I. F. |
| Open | 1670 Kc | | Test Loop | A4 | Oscillator |
| 1400 Kc | 1400 Kc | | Test Loop | A5 | Antenna |
| 600 Kc | 600 Kc | | Test Loop | Check Point | |

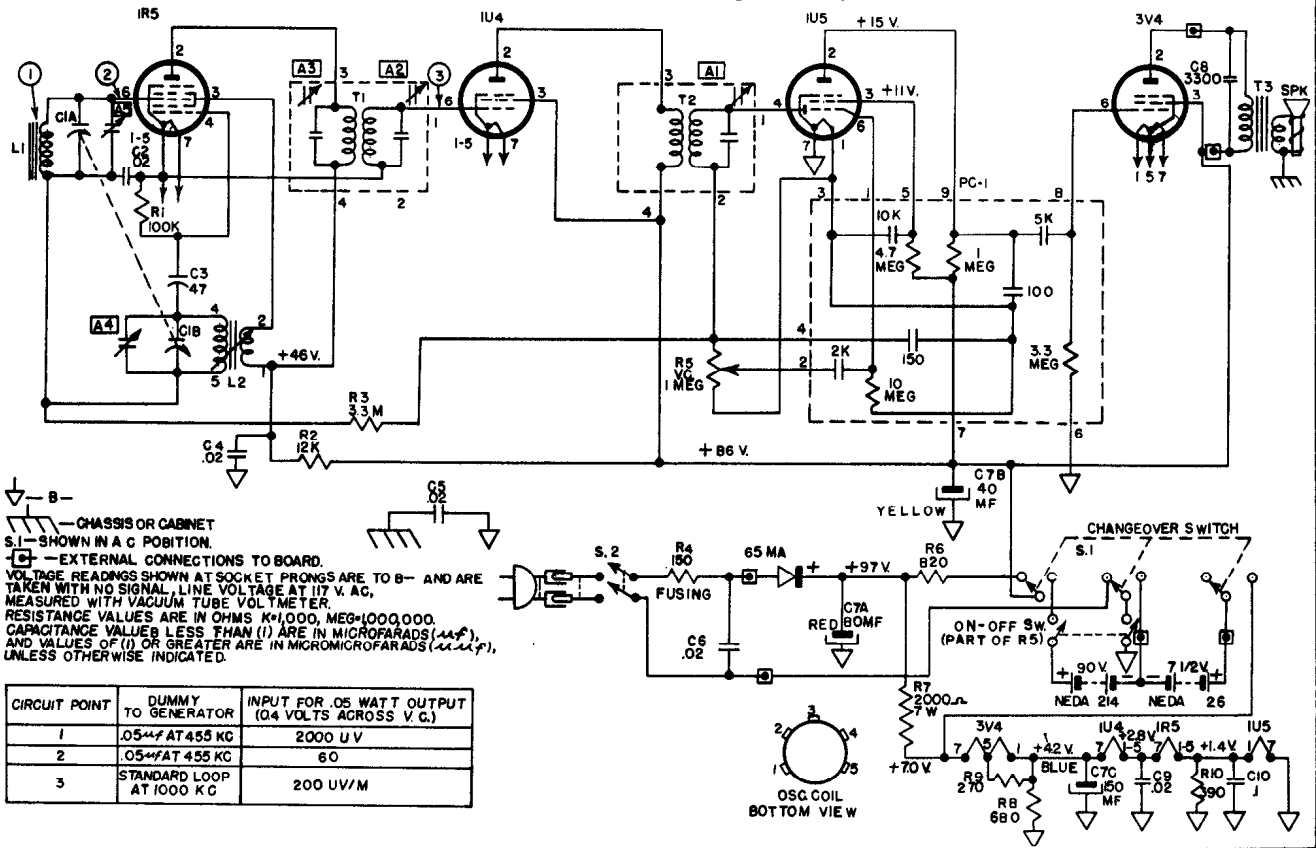
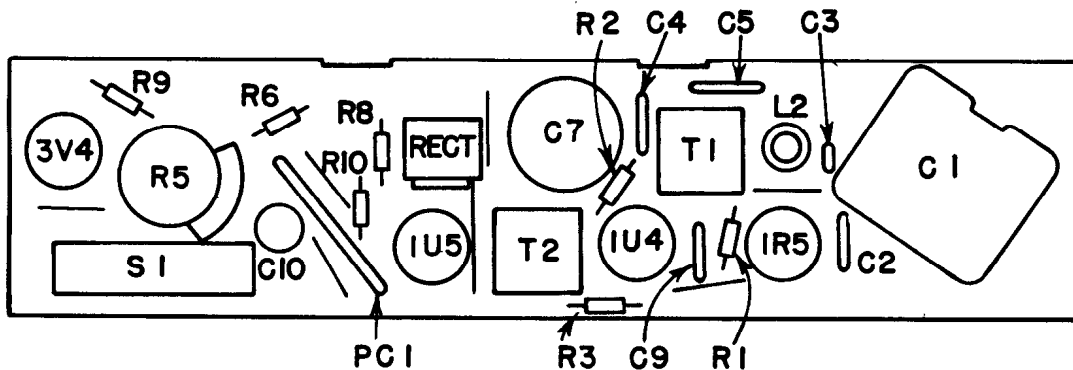

DELCO

BUICK 981968
(Continued from preceding page)

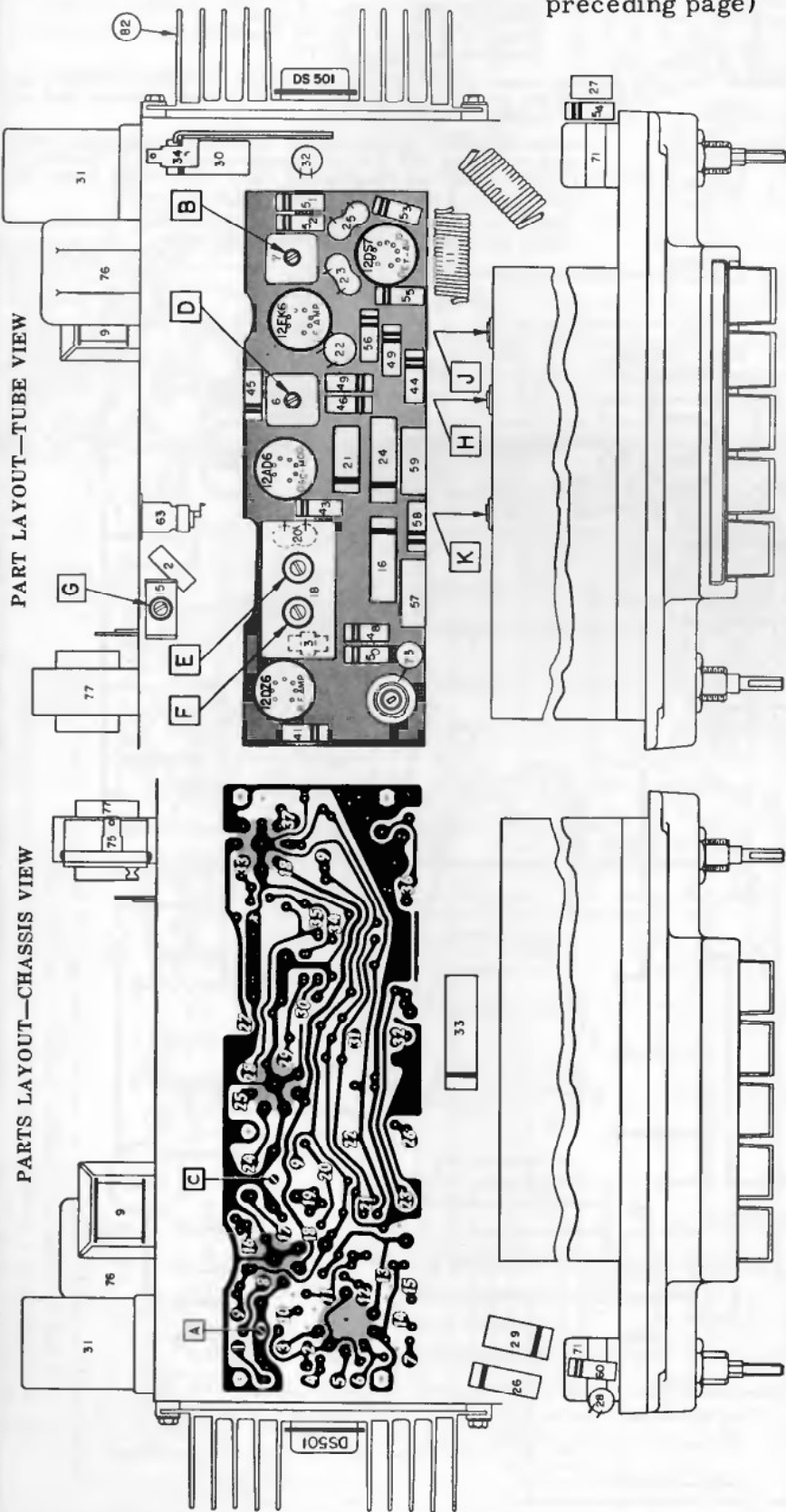

WHITE NUMBERS ON PRINTED CIRCUIT BOARD DRAWING CORRESPOND TO NUMBERS ENCIRCLED ON SCHEMATIC.

ALIGNMENT PROCEDURE

- Output Meter Connections.....Across Voice Coil
- Generator Return.....To Receiver Chassis
- Dummy Antenna.....In Series With Generator
- Volume Control Position.....Maximum Volume
- Tone Control Position.....Treble
- Generator Output...Minimum for Readable Indication

| STEP | SERIES CONDENSER OR DUMMY ANTENNA | CONNECT SIGNAL GENERATOR TO | SIGNAL GENERATOR FREQUENCY | TUNE RECEIVER TO | ADJUST IN SEQUENCE FOR MAX. OUTPUT |
|------|-----------------------------------|-----------------------------|----------------------------|-------------------------|------------------------------------|
| 1 | 0.1 Mfd. | 12DA6 Grid (Pin #7) | 262 KC | High Frequency Stop | A, B, D, C |
| 2 | .000082 Mfd. | Antenna Connector | 1615 KC | High Frequency Stop | *E, F, G |
| 3 | .000082 Mfd. | Antenna Connector | 600 KC | Signal Generator Signal | J, K |
| 4 | .000082 Mfd. | Antenna Connector | 1615 KC | High Frequency Stop | F, G |
| 5 | .000082 Mfd. | Antenna Connector | 900 KC | Signal Generator Signal | L** |

*Before making this adjustment check mechanical setting of oscillator core "H." The rear of the core should be 1% from the mounting end of the coil form. (This measurement is readily made by inserting a suitable plug in the mounting end of the coil form.) Core adjustment should be made with a non-metallic screwdriver.
**L is the pointer adjustment screw which is on the connecting link, between the pointer assembly and the parallel guide bar. It should be adjusted so that the dial pointer corresponds with the 900 KC mark on the dial.

DELCO

BUICK 981970
 OLDSMOBILE 989172
 PONTIAC 988978

Continued on the next page,
 adjacent at right.

SCHEMATIC DATA

Voltages measured terminal to chassis with a VTVM—no signal. The portable unit voltages are taken with a battery voltage of 5.2 volts. Rack unit voltages taken with 12 volts at illus. 37.

Total "A" Drain in Car 1.3 amps.
 Total "A" Drain of Portable 6 ma.
 Tolerance on Voltage $\pm 10\%$.

Resistances are $\pm 20\%$. Ohmmeter reading in transistor circuits are affected by meter battery polarity. Check in both directions and use highest reading.

*—Before measuring transistor voltages, the shorting type speaker socket must be opened and a 4 ohm speaker connected. If transistor is replaced, adjust bias potentiometer (Illus. 84) to obtain proper collector voltage with 12 volts input to radio.

**—Illus. 77 is a fuse resistor for the DS 501 transistor. An open fuse resistor will cause 0 volts at transistor collector.

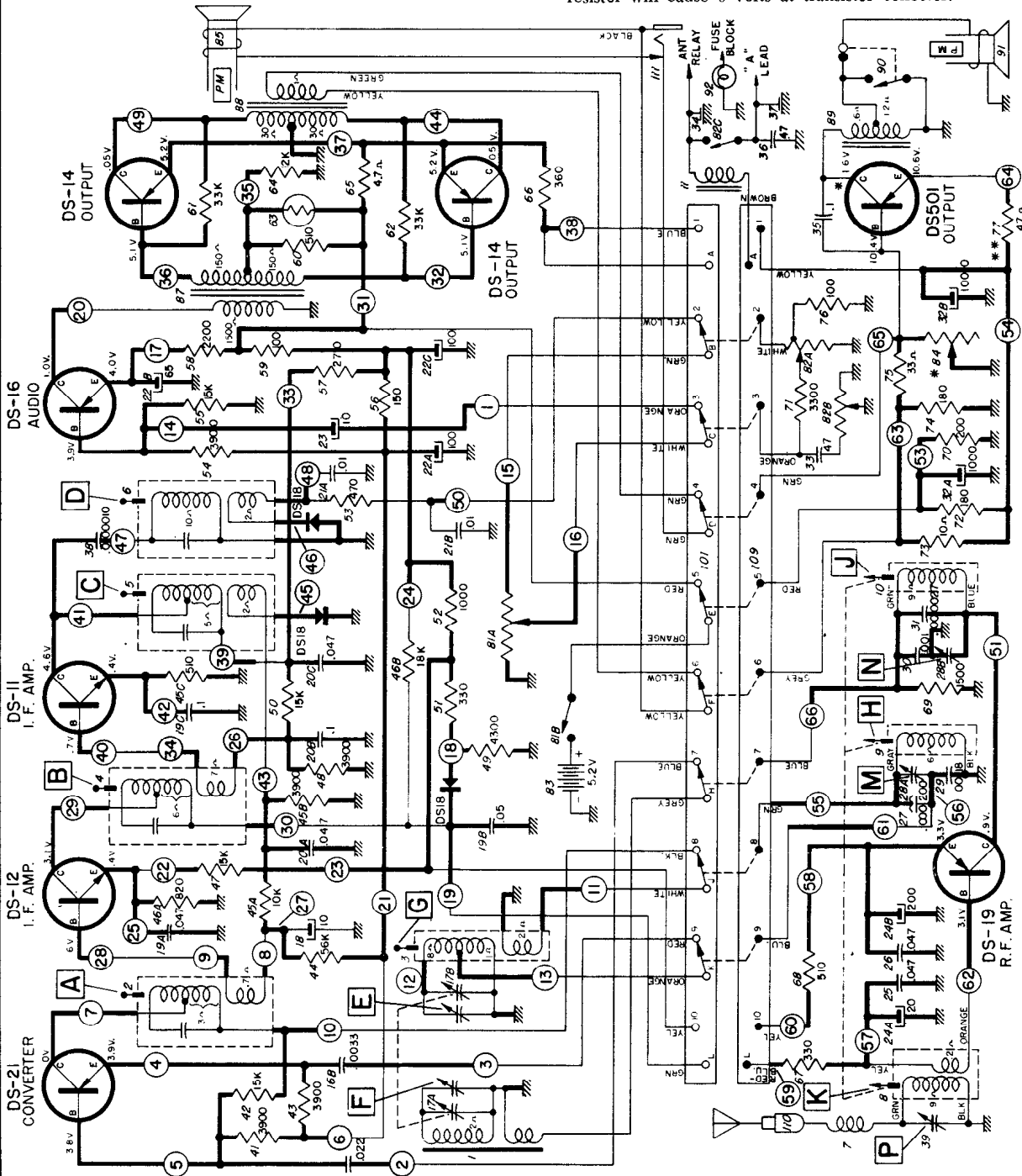

Isolate trouble to portable section or car unit by pulling portable section out of car.

- A. If it fails to operate as a portable, trouble is in portable unit.
- B. If it operates as a portable but not in the car, trouble is in car unit or car antenna.
- C. If it operates in car but not as a portable, check batteries, portable antenna and interconnecting socket

VOLUME R-19, MOST-OFTEN-NEEDED 1959 RADIO SERVICING INFORMATION

DELCO
 BUICK 981970
 OLDSMOBILE 989172
 PONTIAC 988978

(Continued)

NOTE: WHITE NUMBERS ON PRINTED CIRCUIT DRAWINGS CORRESPOND TO ENCIRCLED NUMBERS ON SCHEMATIC DIAGRAM.

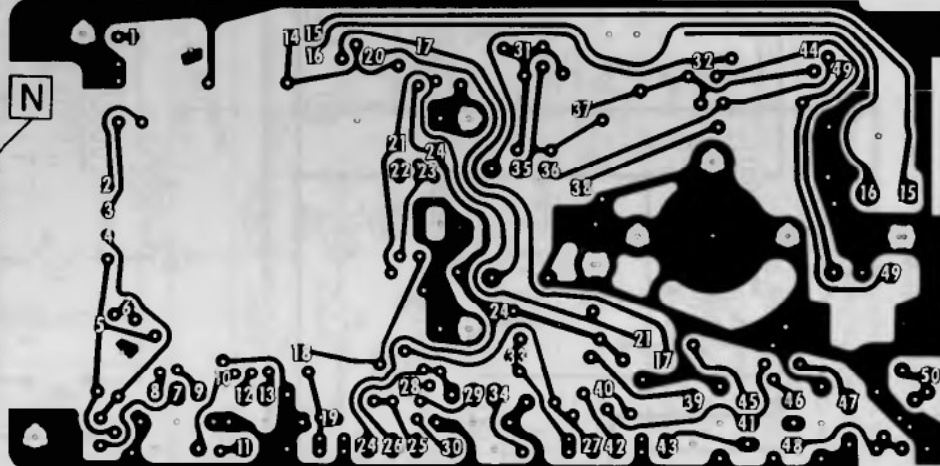
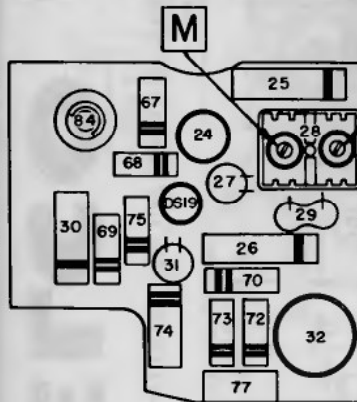
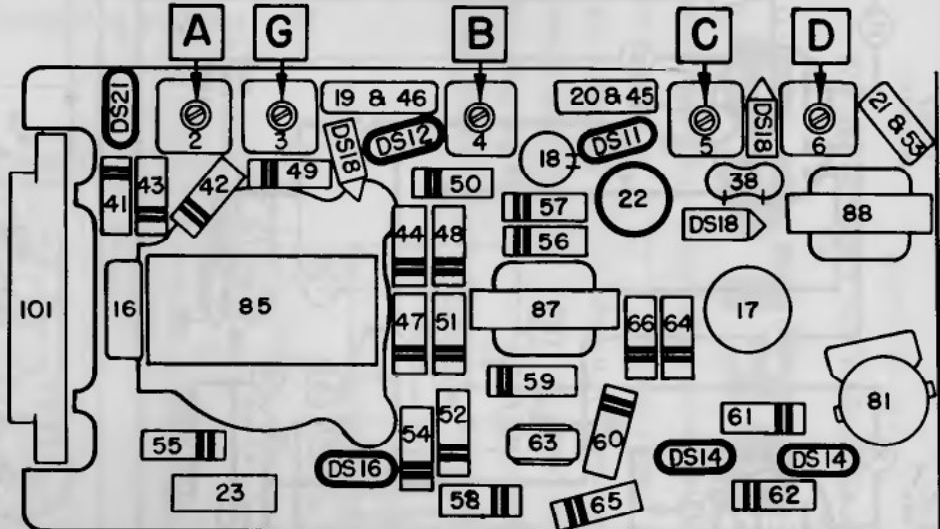
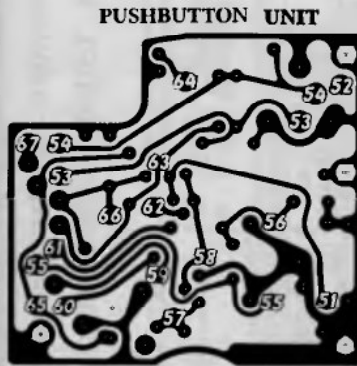

ALIGNMENT

Set radio volume control to maximum. Read output at speaker; keep below .5 volt.

| Step | Method Of Connecting Generator | Connect Generator To | Signal Frequency | Tune Receiver To | Adjust In Sequence For Max. Output |
|--|--------------------------------|--------------------------------------|------------------|-------------------|---|
| 1 | Thru .1 mfd. Cap. | Converter Base (Island 5) | 465 KC | High freq. stop | A, B, C, D E Trimmer on variable (nearest batteries) |
| 2 | Pick up loop | By induction to antenna | 1680 KC | High freq. stop | F Trimmer on variable (nearest vol. control) |
| 3 | Do not use | Align on noise (Lights, razor, etc.) | Noise | Near 600 KC | G |
| 4 | Pick up loop | By induction to antenna | 1400 KC | Signal Gen. freq. | F |
| If it is necessary to align pushbutton tuner, connect portable to it and follow the steps below. | | | | | |
| 5 | .000068 mfd., Cap. | Antenna connector | 1615 KC | High freq. stop | *M, N, P |
| 6 | .000068 mfd., Cap. | Antenna connector | 600 KC | Signal Gen. freq. | J, K |
| 7 | .000068 mfd., Cap. | Antenna connector | 1615 KC | Signal Gen. freq. | N, P |
| 8 | .000068 mfd., Cap. | Antenna connector | 1000 KC | Signal Gen. freq. | L** |

*Before making this adjustment, check mechanical setting of oscillator core "H," with radio tuned to high frequency limit. The rear of the core should be 1/8" from the mounting end of the coil form. (This measurement is readily made by inserting a ruled plug in the rear of the coil form.)

**L is the pointer adjustment screw which is on the connecting link, between the pointer assembly and the parallel guide bar. It should be adjusted so that the dial pointer corresponds with the 1100 KC mark on the dial.

DELCO CHEVROLET MODEL 987888
(Continued from preceding page at left)

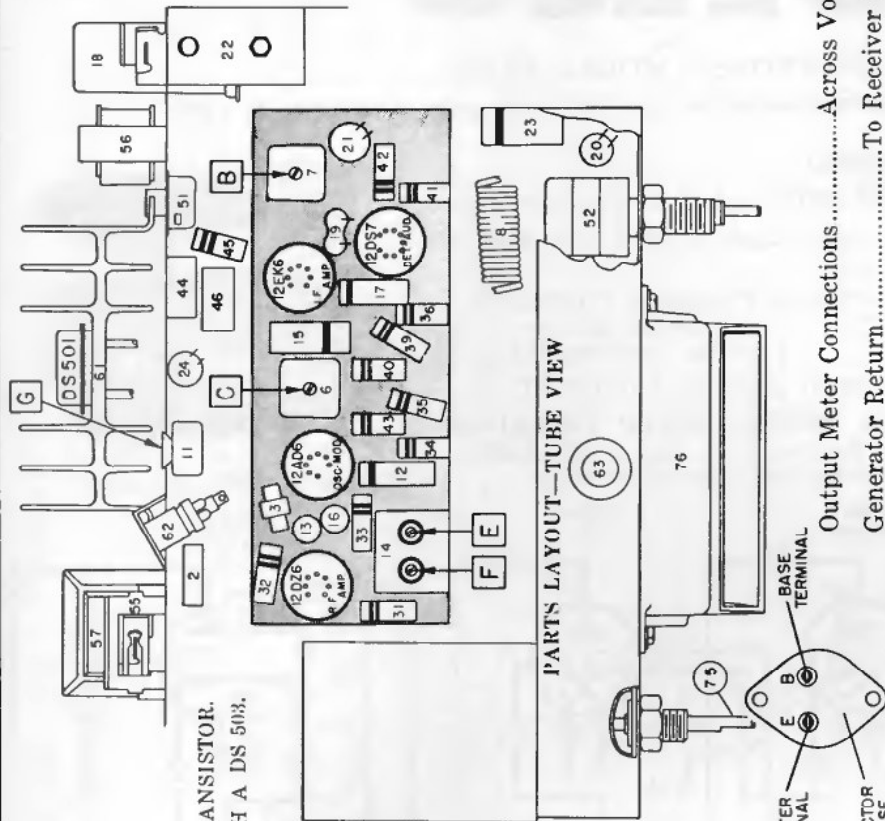

SOME RADIOS USE A DS 503 TRANSISTOR.
IT SHOULD BE REPLACED WITH A DS 503.

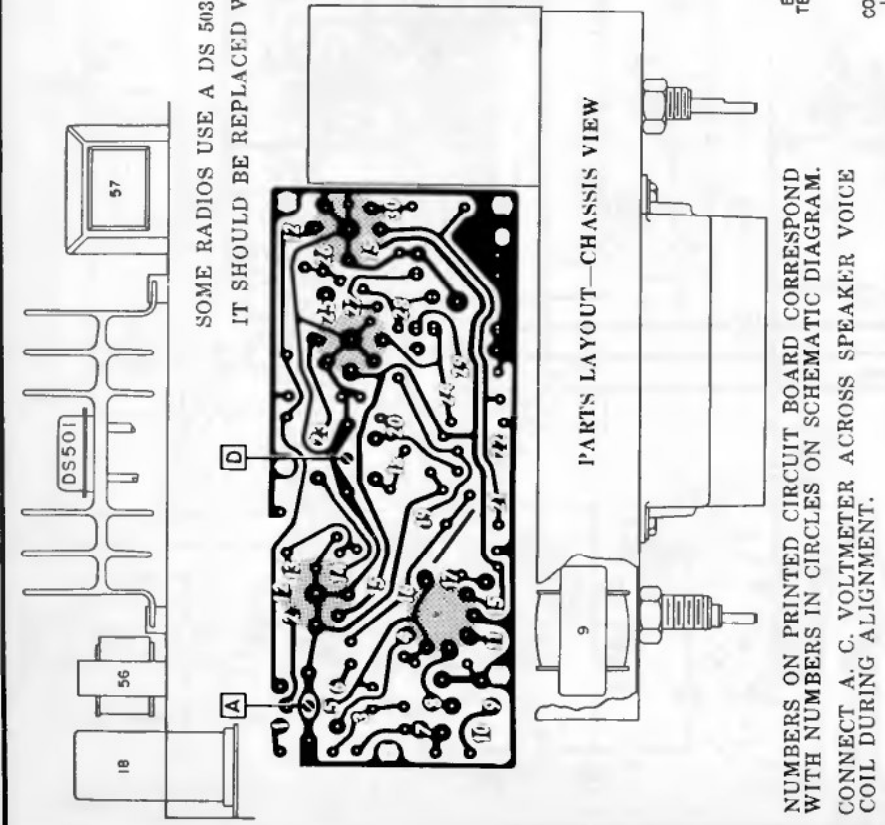

ALIGNMENT PROCEDURE

| STEPS | SERIES CAPACITOR OR DUMMY ANTENNA | SIGNAL GENERATOR CONNECT TO | SIGNAL GENERATOR FREQUENCY | TUNE RECEIVER TO | ADJUST IN SEQUENCE FOR MAX. OUTPUT |
|-------|-----------------------------------|-----------------------------|----------------------------|-------------------------|------------------------------------|
| 1 | 0.1 Mfd. | 12AD6 Grid (Pin #7) | 262 KC | High Frequency Stop | A, B, C, D, |
| 2 | 0.000082 Mfd. | Antenna Connector | 1615 KC | High Frequency Stop | *E, F, G, |
| 3 | 0.000082 Mfd. | Antenna Connector | 600 KC | Signal Generator Signal | J, K |
| 4 | 0.000082 Mfd. | Antenna Connector | 1615 KC | High Frequency Stop | F, G |

*Before making this adjustment check mechanical setting of oscillator core "H." The rear of the core should be 1 1/2" from the mounting end of the coil form. (This measurement is readily made by inserting a suitable plug in the mounting end of the coil form.) Core adjustment should be made with a non-metallic screw driver. With the radio installed and the car antenna plugged in adjust the antenna trimmer "G" for maximum volume with the radio tuned to a weak station between 600 and 1000 KC (see sticker on case.)

- Output Meter Connections.....Across Voice Coil
- Generator Return.....To Receiver Chassis
- Dummy Antenna.....In Series With Generator
- Volume Control Position.....Maximum Volume
- Tone Control Position.....Treble Position
- Generator Output.....Minimum for Readable Indication

DELCO

CHEVROLET MODEL 987888
(Continued)

DELCO

CHEVROLET MODEL 987891
(Continued from preceding page)

PARTS LAYOUT—TUBE VIEW

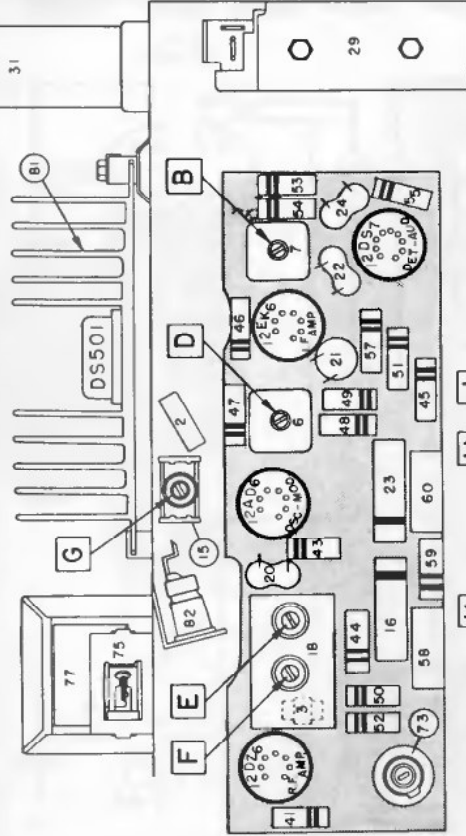

PARTS LAYOUT—CHASSIS VIEW

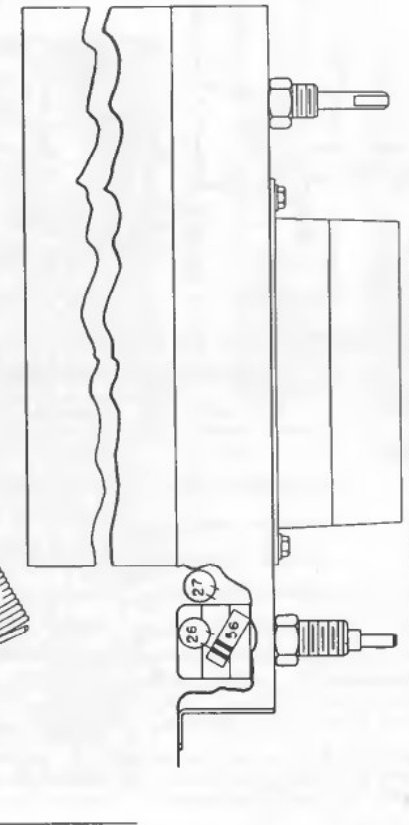
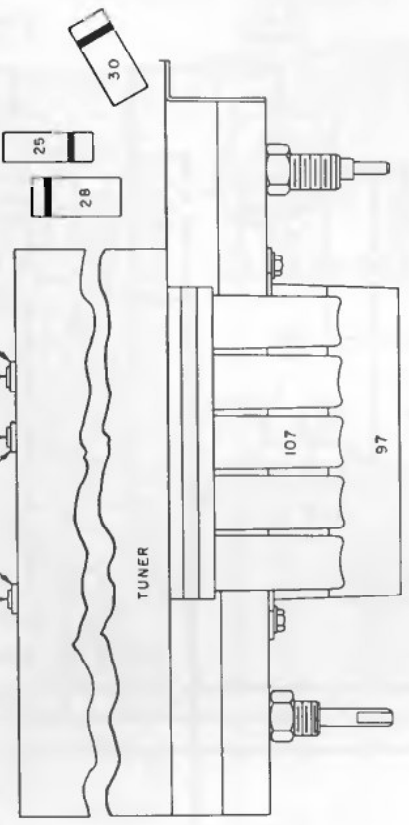
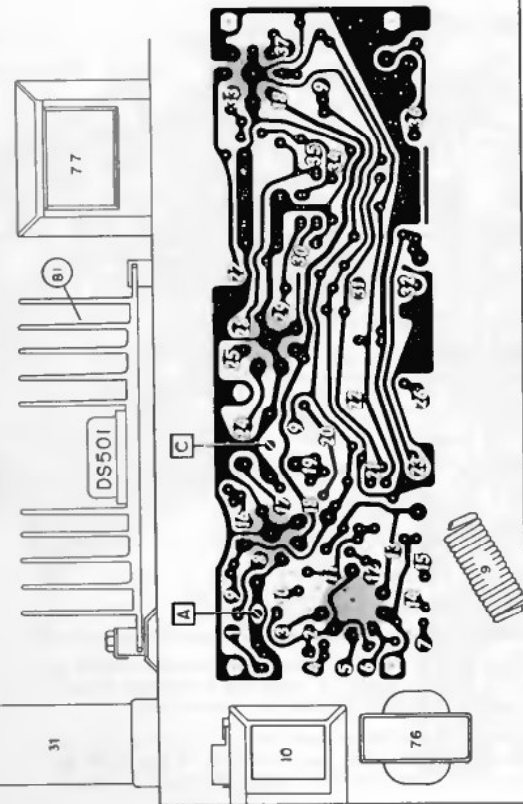

BASIC TROUBLESHOOTING PROCEDURE

1. Put ear next to speaker and turn radio on; if slight "thump" is heard as this is done, trouble is not in transistor stage—try new tubes.
2. If no "thump" at all is heard, measure voltage from transistor case to radio chassis. If 1-2 volts is present, transistor is operating normally and trouble is either in speaker or one of the tube circuits.
3. If no voltage is present in step 2, check transistor circuits and particularly the transistor fuse resistor, Illustration No. 60. This resistor is mounted between points 32 and 26 on circuit board.

NOTE: ILLUS. 60 IS FUSE RESISTOR. OPEN FUSE RESISTOR MAKES TRANSISTOR COLLECTOR VOLTAGE 0 VOLTS.
CONNECT A. C. VOLTMETER ACROSS SPEAKER VOICE COIL DURING ALIGNMENT.
NUMBERS ON PRINTED CIRCUIT BOARD CORRESPOND WITH NUMBERS IN CIRCLES ON SCHEMATIC DIAGRAM.
ILLUS. 17, 19, AND 42 ARE LOCATED UNDER SHIELD OF DUAL TRIMMER ILLUS. 18.

Follow alignment procedure shown for Buick Model 981968, but use the above drawings for location of trimmers.



DS 501—Transistor Terminals

DELCO

PONTIAC MODEL 988976
(Additional material on next page at right)

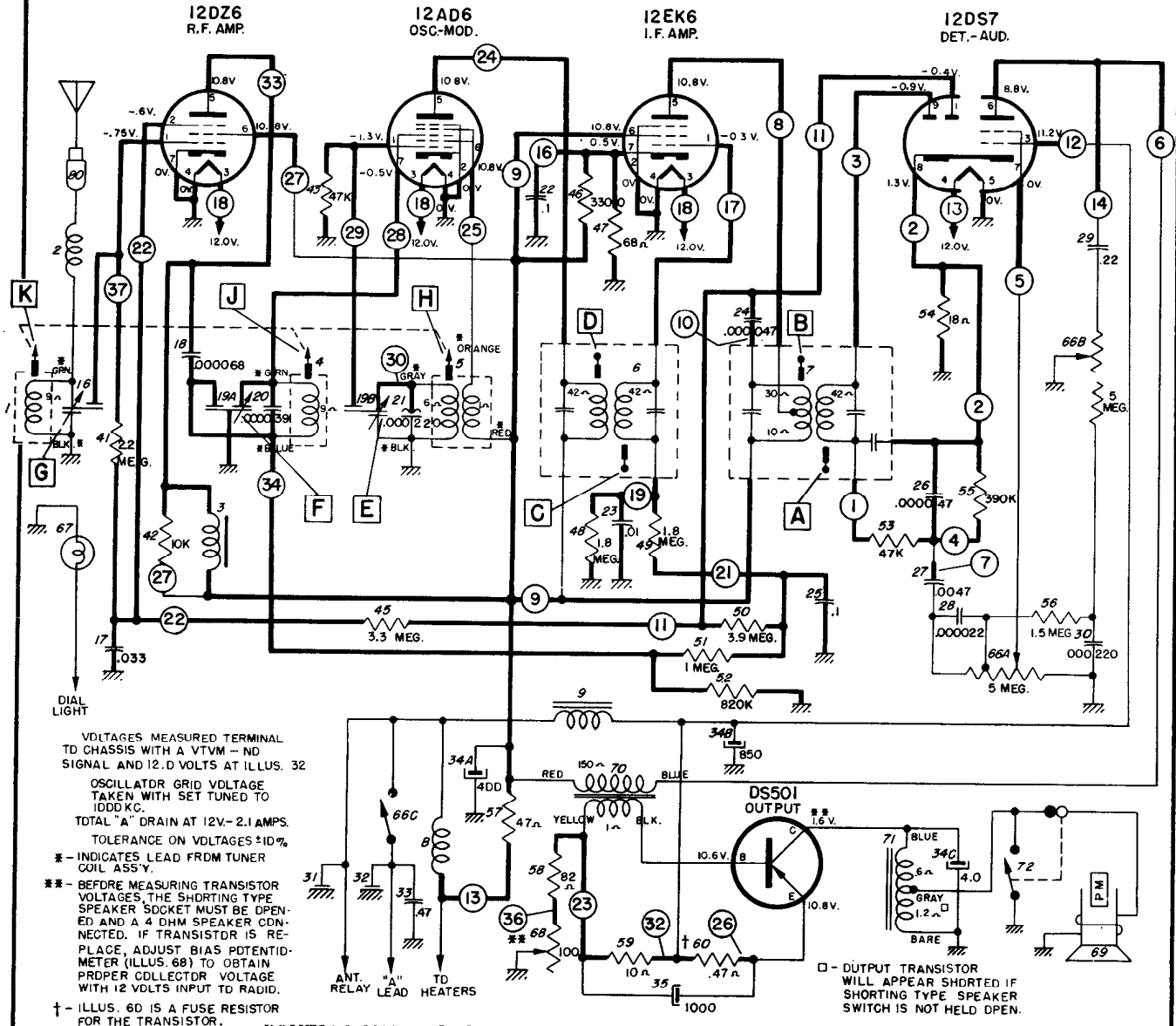

PONTIAC 988976—PRINTED CIRCUIT SHOWN IN HEAVY LINES.

ALIGNMENT PROCEDURE:

| STEPS | SERIES CAPACITOR TO DUMMY ANTENNA | CONNECT SIGNAL GENERATOR TO | SIGNAL GENERATOR FREQUENCY | TUNE RECEIVER TO | ADJUST IN SEQUENCE FOR MAX. OUTPUT |
|-------|-----------------------------------|-----------------------------|----------------------------|-------------------------|------------------------------------|
| 1 | 0.1 Mfd. | 12AD6 Grid (Pin #7) | 262 KC | High Frequency Stop | A, B, C, D |
| 2 | 0.000068 Mfd. | Antenna Connector | 1615 KC | High Frequency Stop | *E, F, G |
| 3 | 0.000068 Mfd. | Antenna Connector | 600 KC | Signal Generator Signal | J, K |
| 4 | 0.000068 Mfd. | Antenna Connector | 1615 KC | High Frequency Stop | F, G |
| 5 | 0.000068 Mfd. | Antenna Connector | 1100 KC | Signal Generator Signal | L** |

*Before making this adjustment check mechanical setting of oscillator core "H." The rear of the core should be 1/16" from the mounting end of the coil form. (This measurement is readily made by inserting a suitable plug in the mounting end of the coil form.) Core adjustment should be made with a non-metallic screwdriver.

**L is the pointer adjustment which is on the connecting link, between the pointer assembly and core guide bar (See tuner Dwg.). It should be adjusted so that when looking directly at the dial the pointer is on the 1100 KC mark. This setting is to give the correct relationship between the pointer and the dial when the radio is installed in a car.

DELCO

PONTIAC MODEL 988976

(Continued from preceding page at left)

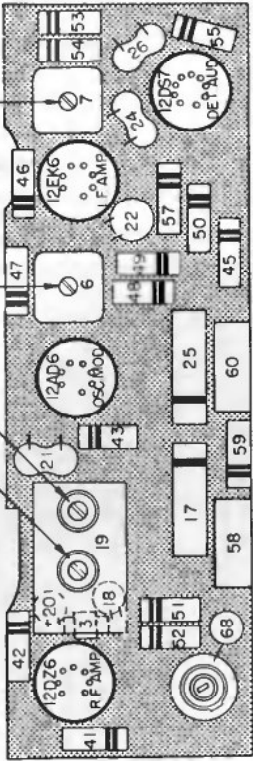
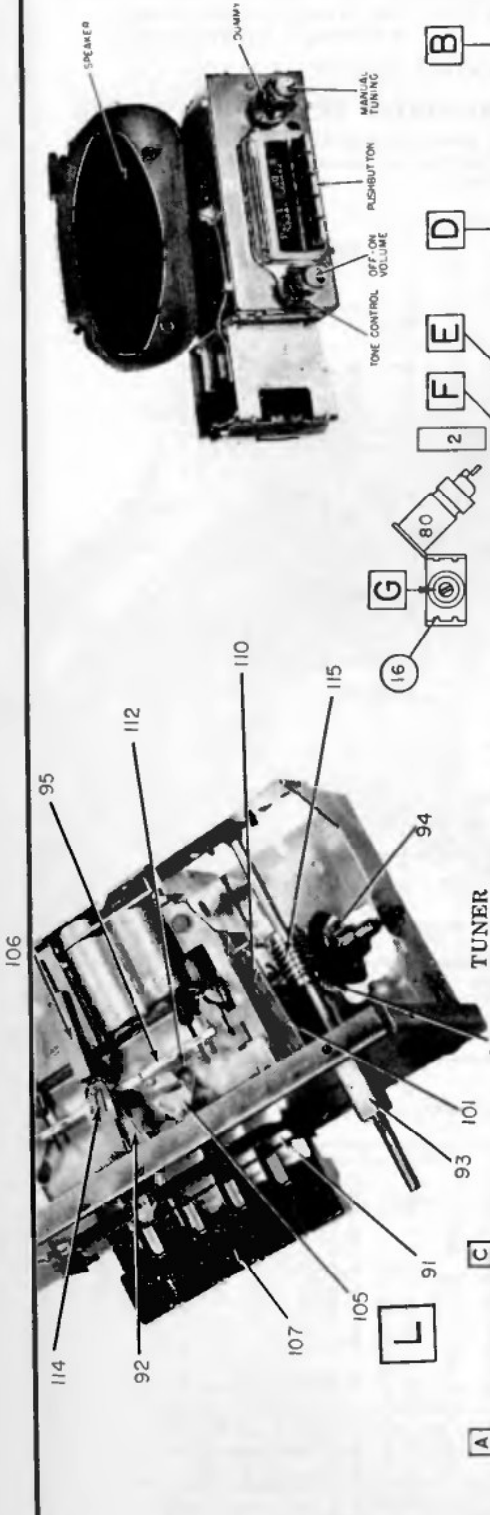

PARTS LAYOUT—TUBE VIEW

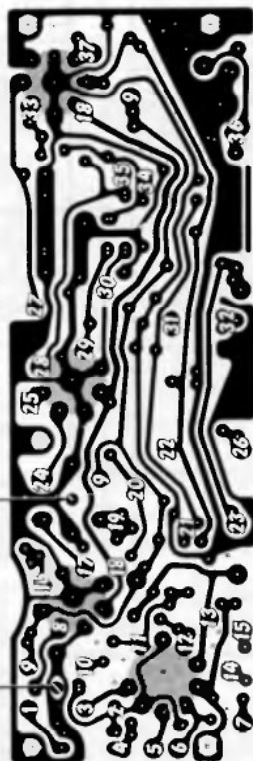

PARTS LAYOUT—CHASSIS VIEW

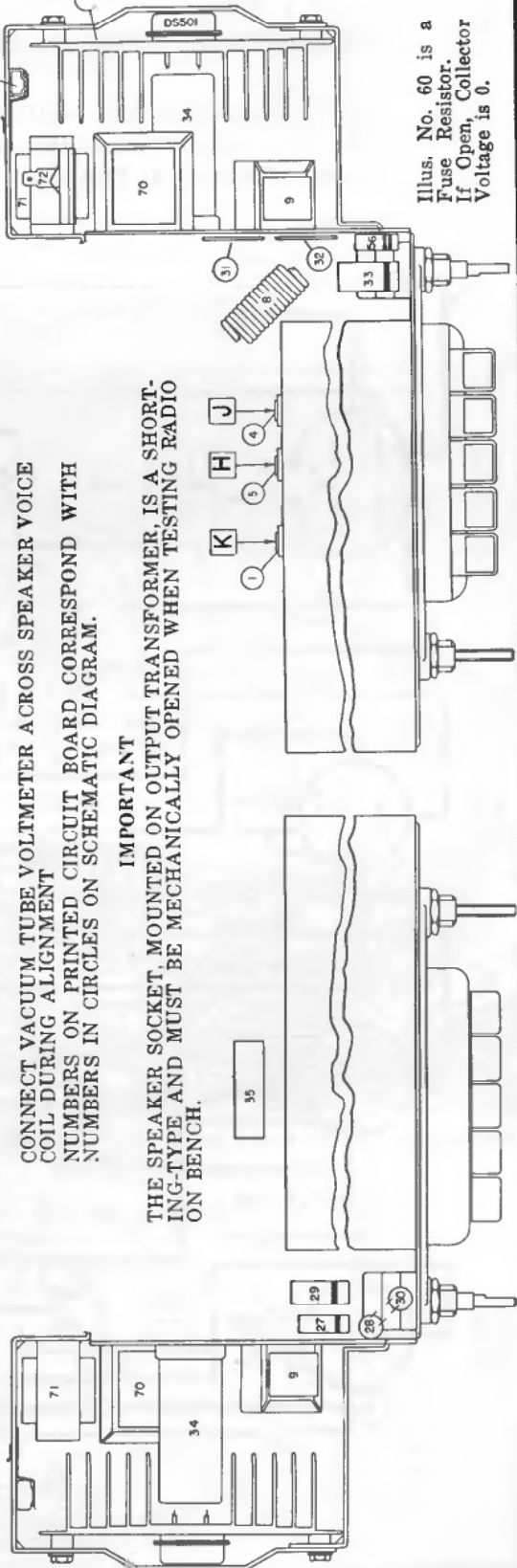

Illus. No. 60 is a Fuse Resistor. If Open, Collector Voltage is 0.

CONNECT VACUUM TUBE VOLTMETER ACROSS SPEAKER VOICE COIL DURING ALIGNMENT NUMBERS ON PRINTED CIRCUIT BOARD CORRESPOND WITH NUMBERS IN CIRCLES ON SCHEMATIC DIAGRAM.

IMPORTANT

THE SPEAKER SOCKET, MOUNTED ON OUTPUT TRANSFORMER, IS A SHORTING-TYPE AND MUST BE MECHANICALLY OPENED WHEN TESTING RADIO ON BENCH.

DELCO

OLDSMOBILE MODEL 989170

(For alignment and additional service information see next page adjacent at right)

GENERAL

MOUNTING—All 1959 Oldsmobile Cars.
SPEAKER—6"x9" Elliptical, Permanent Magnet.

TUNING—Manual and 5 P. B. Mechanical.

ANTENNA TRIMMER COMPENSATION—for Antennas Between 0.000050 - 0.000090 Mfd.

TUNING RANGE—540-1600 KC.

PUSHBUTTON SETUP PROCEDURE

Pull Pushbutton to the left and out. Tune in desired station manually. Push button all the way in.

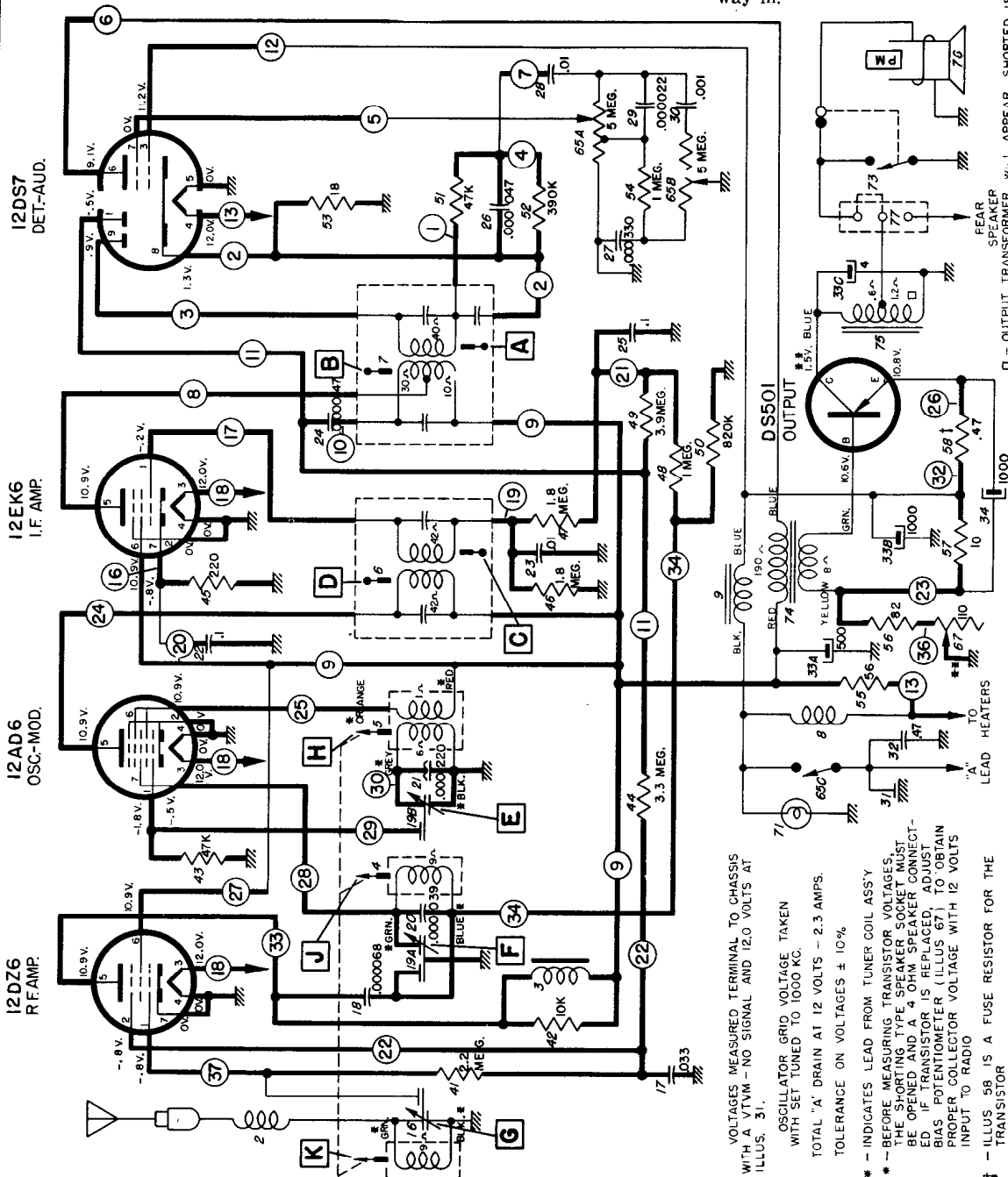

VOLTAGES MEASURED TERMINAL TO CHASSIS WITH A VTVM—NO SIGNAL AND 120 VOLTS AT ILLUS. 51.

OSCILLATOR GRID VOLTAGE TAKEN WITH SET TUNED TO 1000 KC. TOTAL "A" DRAIN AT 12 VOLTS - 2.3 AMPS. TOLERANCE ON VOLTAGES ± 10%.

* - INDICATES LEAD FROM TUNER COIL ASSY
 ** - BEFORE MEASURING TRANSISTOR VOLTAGES, BE OPENED AND A 50Ω SPEAKER CONNECTED. IF TRANSISTOR IS REPLACED, ADJUST BIAS POTENTIOMETER (ILLUS. 67) TO OBTAIN PROPER COLLECTOR VOLTAGE WITH 12 VOLTS INPUT TO RADIO
 † - ILLUS. 58 IS A FUSE RESISTOR FOR THE TRANSISTOR

□ - OUTPUT TRANSFORMER WILL APPEAR SHORTED IF SHORTING TYPE SPEAKER SWITCH IS NOT OPENED.

OLDSMOBILE 989170—PRINTED CIRCUIT SHOWN IN HEAVY LINES

ILLUS. 77 IS SOCKET FOR REAR SPEAKER CONTROL AND INCORPORATES A SHORTING SWITCH. WHEN JUMPER OR CONTROL ARE REMOVED THE OUTPUT TRANSFORMER IS SHORTED.

DELCO

OLDSMOBILE MODEL 989170
(Continued from preceding page)

ALIGNMENT PROCEDURE:

Output Meter Connections.....Across Voice Coil
Generator Return.....To Receiver Chassis
Dummy Antenna.....In Series With Generator
Volume Control Position.....Maximum Volume
Tone Control Position.....Treble Position
Generator Output.....Minimum for Readable Indication

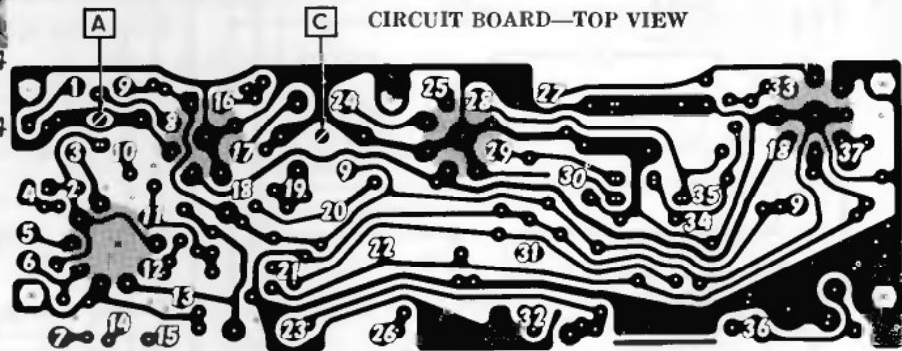
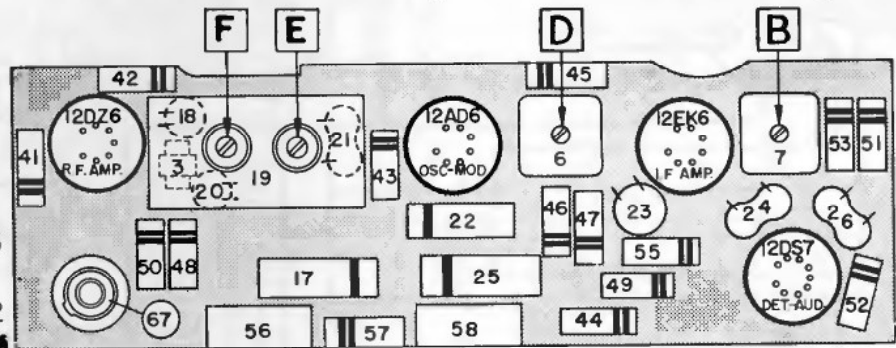
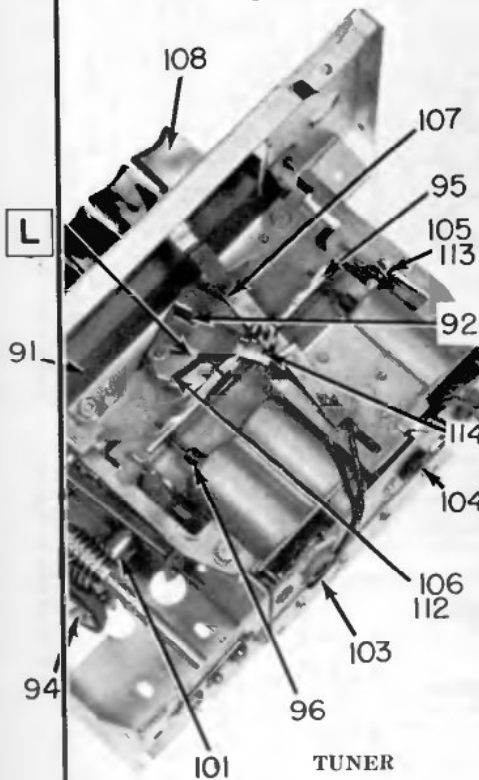
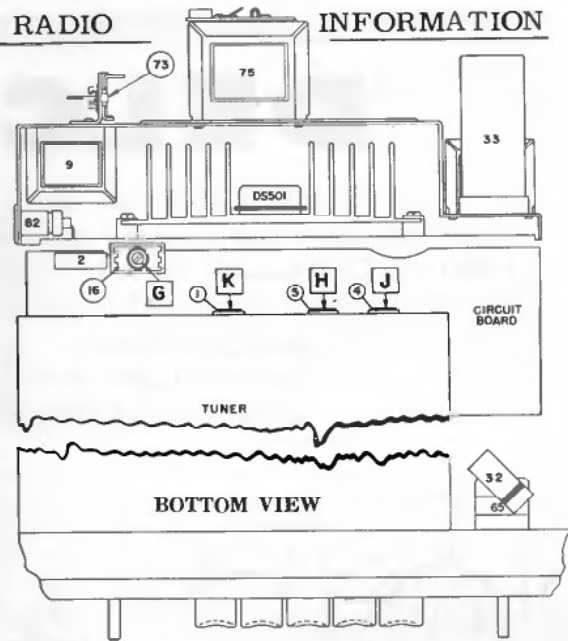

WHITE NUMBERS ON PRINTED CIRCUIT BOARD DRAWING CORRESPOND TO NUMBERS ENCIRCLED ON SCHEMATIC.

| STEPS | SERIES CAPACITOR OR DUMMY ANTENNA | CONNECT SIGNAL GENERATOR TO | SIGNAL GENERATOR FREQUENCY | TUNE RECEIVER TO | ADJUST IN SEQUENCE FOR MAX. OUTPUT |
|-------|-----------------------------------|-----------------------------|----------------------------|-------------------------|------------------------------------|
| 1 | 0.1 Mfd. | 12AD6 Grid (Pin #7) | 262 KC | High Frequency Stop | A, B, C, D |
| 2 | 0.000068 Mfd. | Antenna Connector | 1615 KC | High Frequency Stop | *E, F, G |
| 3 | 0.000068 Mfd. | Antenna Connector | 600 KC | Signal Generator Signal | J, K |
| 4 | 0.000068 Mfd. | Antenna Connector | 1615 KC | High Frequency Stop | F, G |
| 5 | 0.000068 Mfd. | Antenna Connector | 1100 KC | Signal Generator Signal | L** |

*Before making this adjustment check mechanical setting of oscillator core "H." The rear of the core should be 1/8" from the mounting end of the coil form. (This measurement is readily made by inserting a suitable plug in the mounting end of the coil form.) Core adjustment should be made with a non-metallic screwdriver.

**L is the pointer adjustment which is on the connecting link, between the pointer assembly and core guide bar (See tuner Dwg.). It should be adjusted so that when looking directly at the dial the pointer is on the 1100 KC mark. This setting is to give the correct relationship between the pointer and the dial when the radio is installed in a car.

DELCO

OLDSMOBILE 989171

Material below and the page adjacent at right is exact for Oldsmobile 989171. The following sets are practically the same electrically.

BUICK 981969,
CHEVROLET 987893,
PONTIAC 988977

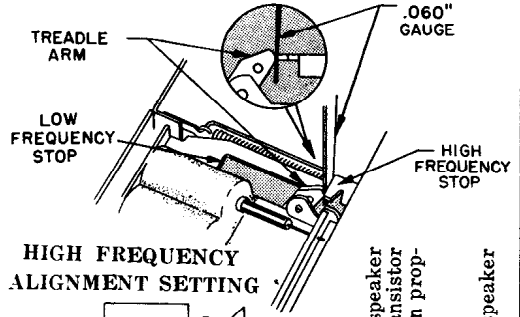

HIGH FREQUENCY ALIGNMENT SETTING

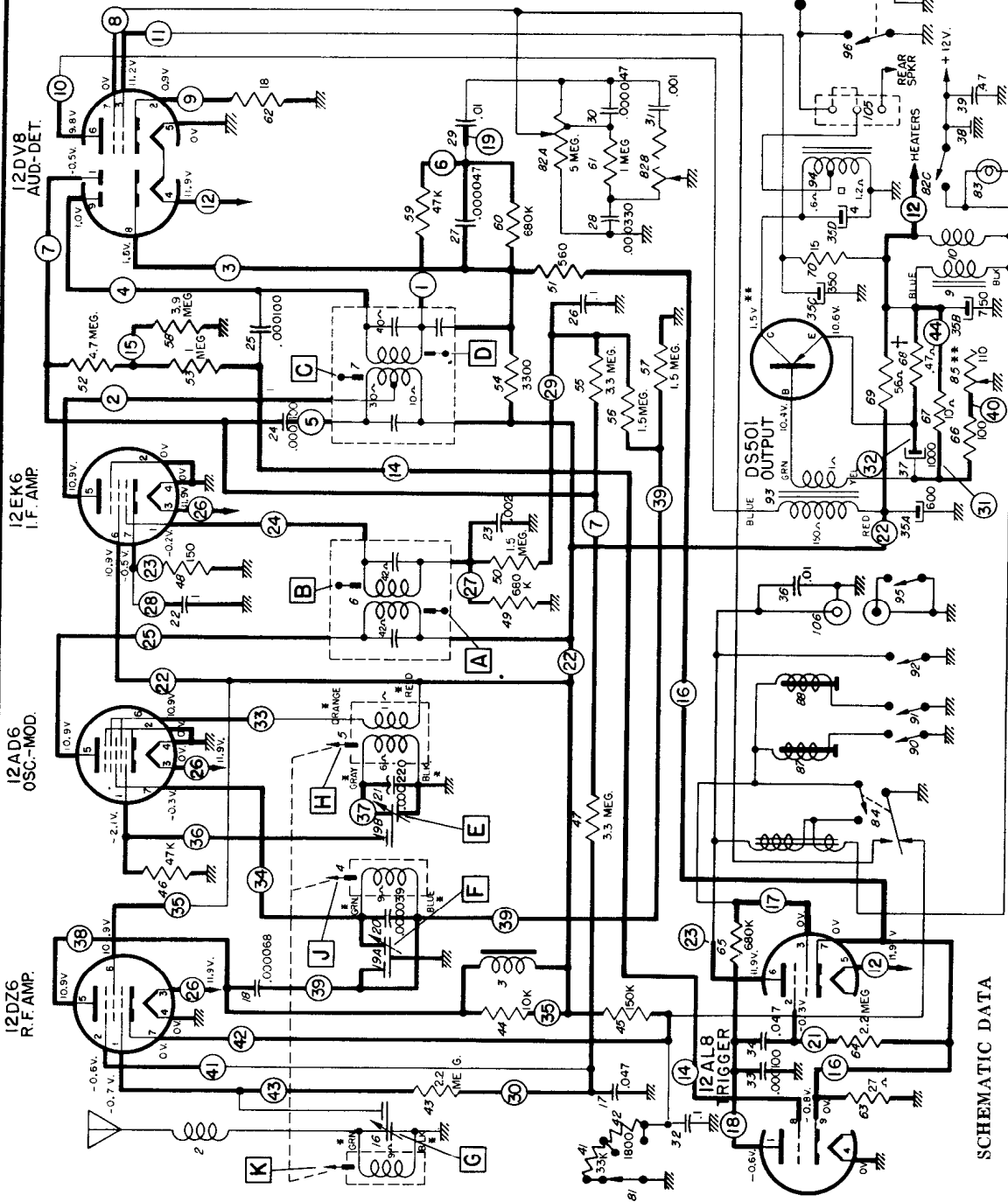

SCHEMATIC DATA

Voltages measured terminal to chassis with a VTVM - No signal and 12.0 volts at illustration 38.

Oscillator grid voltage taken with set tuned to 1000 kc.

Total "A" drain at 12 volts - 2.6 amps.

Tolerance on voltages ±10%.

*—Indicates lead from tuner coil assembly.

**—Before measuring transistor voltages, the shorting type speaker socket must be opened and a 4 ohm speaker connected. If transistor is replaced, adjust bias potentiometer (Illustration 85) to obtain proper collector voltage with 12 volts input to radio.

+—Illustration 68 is a fuse resistor for the transistor.

□—Output transformer may appear shorted if shorting type speaker socket is not held open.

OLDSMOBILE 989171 PRINTED CIRCUIT SHOWN IN HEAVY LINES

VOLUME R-19, MOST-OFTEN-NEEDED 1959 RADIO SERVICING INFORMATION

DELCO OLDSMOBILE 989171 (Continued)

For list of similar models, see preceding page.

WHITE NUMBERS ON PRINTED CIRCUIT DRAWING CORRESPOND TO THE ENCIRCLED NUMBERS ON SCHEMATIC.

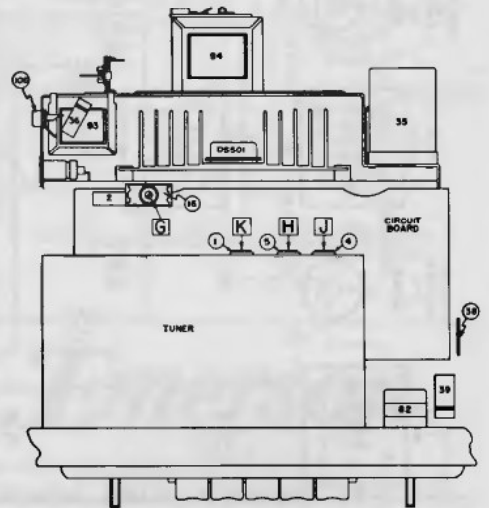
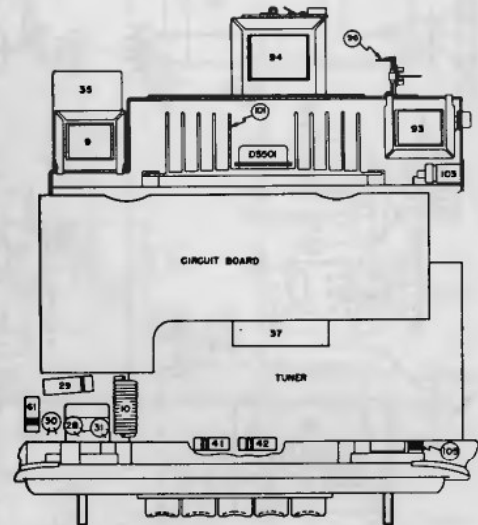
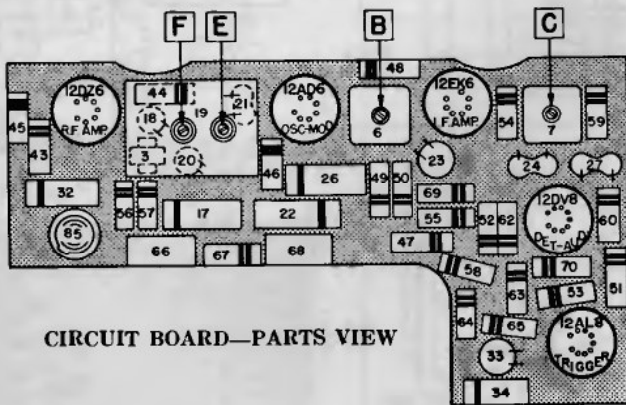
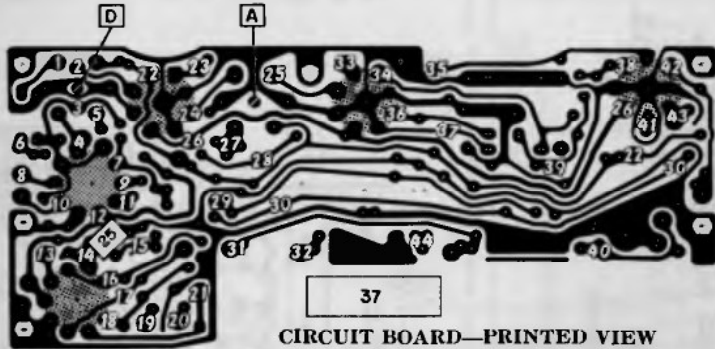

SIGNAL SEEKING TUNER ALIGNMENT PROCEDURE

NOTE: When aligning the signal seeker tuner type radio, be sure to use a vacuum tube voltmeter as indicated.

- Output Meter Connection.....VTVM from AVC line (#27 Island-Circuit Board) To Chassis
- Generator Return.....Receiver Chassis
- Dummy Antenna.....In Series With Generator
- Sensitivity Control.....Maximum
- Volume Control.....Maximum Volume
- Tone Control.....Treble
- Generator Output.....Not to exceed 2 volts at VTVM

| STEP | DUMMY ANTENNA | CONNECT SIGNAL GENERATOR TO | SIGNAL GENERATOR FREQUENCY | TUNE RECEIVER TO | ADJUST IN SEQUENCE FOR OUTPUT INDICATED |
|------|---------------|-----------------------------|----------------------------|-------------------------|---|
| 1 | 0.1 Mfd. | 12AD6 Grid (Pin 7) | 262 KC | *High Frequency Stop | A, B, C (Max.), D (Min.) |
| 2 | .000068 Mfd. | Antenna Connector | 1615 KC | High Frequency Stop | **E, F, G (Max.) |
| 3 | .000068 Mfd. | Antenna Connector | 600 KC | Signal Generator Signal | J, K (Max.) |
| 4 | .000068 Mfd. | Antenna Connector | 1615 KC | Signal Generator Signal | F, G (Max.) |
| 5 | .000068 Mfd. | Antenna Connector | 1100 KC | Signal Generator Signal | ***L |

*To tune to high frequency, put a .070" feeler gauge in slot against the high frequency stop. (See Page 30. Depress station selector bar and allow the treadle bar arm to run against the feeler gauge. Turn the radio off and then back on. This positions the tuner near the point where the treadle switch closes.

**Before making this adjustment, check the setting of oscillator core "H." The rear of the core should be 1/4" from the mounting end of the coil form. This measurement is readily made by inserting a suitable plug in the mounting end of the coil form. The core adjustment is made from the mounting end of the coil form with a non-metallic screwdriver.

***"L" is the pointer adjustment slot on the pointer assembly—adjust so pointer reads 1100 KC. With the radio installed and the antenna plugged in, adjust the antenna trimmer "C" for maximum volume with the radio tuned to a weak station between 600 and 1000 KC (see sticker on case.)

EMERSON RADIO
Model 877, Chassis 120392B

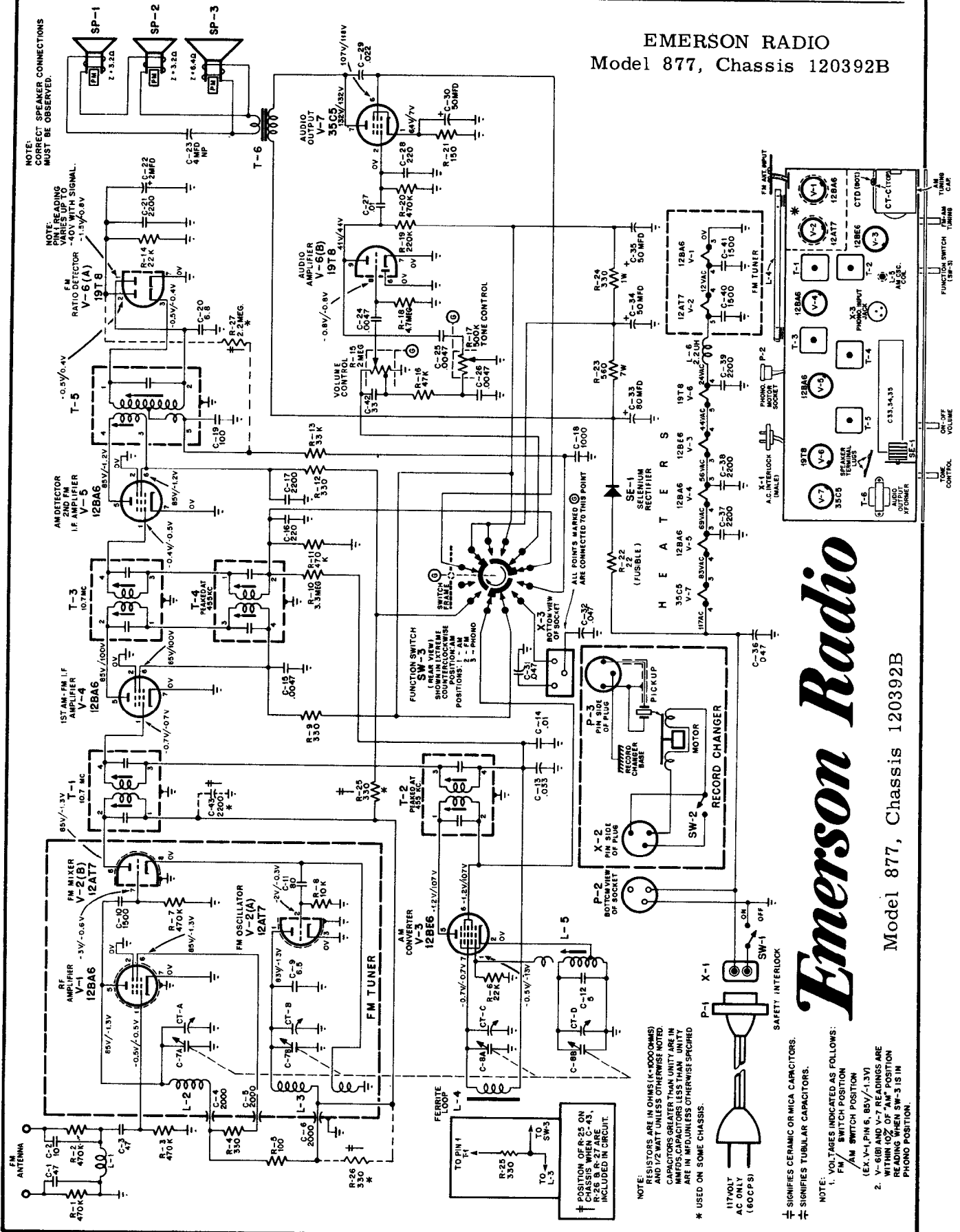

Emerson Radio

Model 877, Chassis 120392B

Emerson

Models 834X, 890, 892A, Chassis 120394B

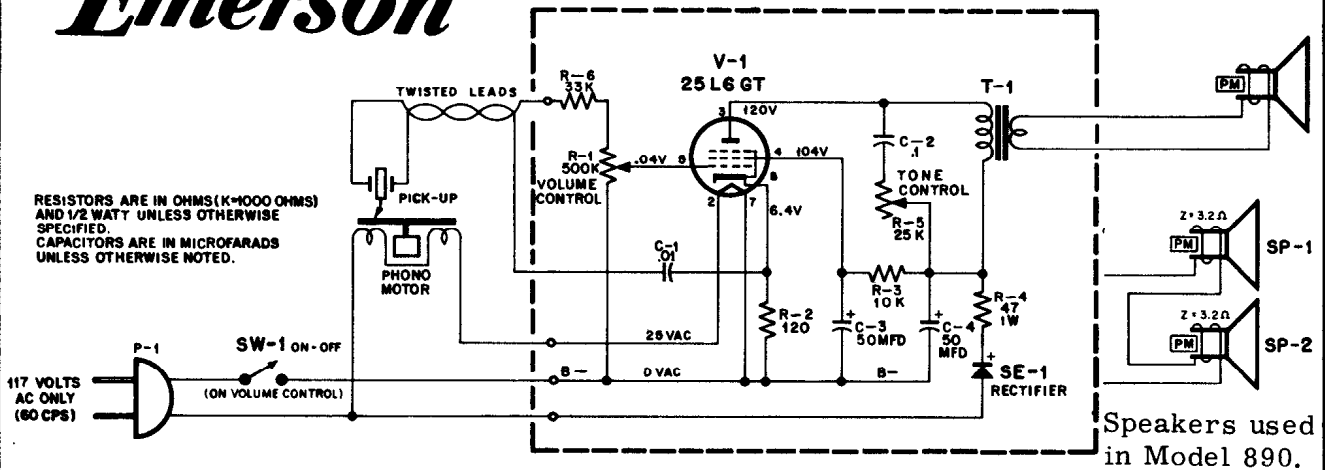

Emerson

MODELS:
893B, 894B

CHASSIS:
120430B, 432B

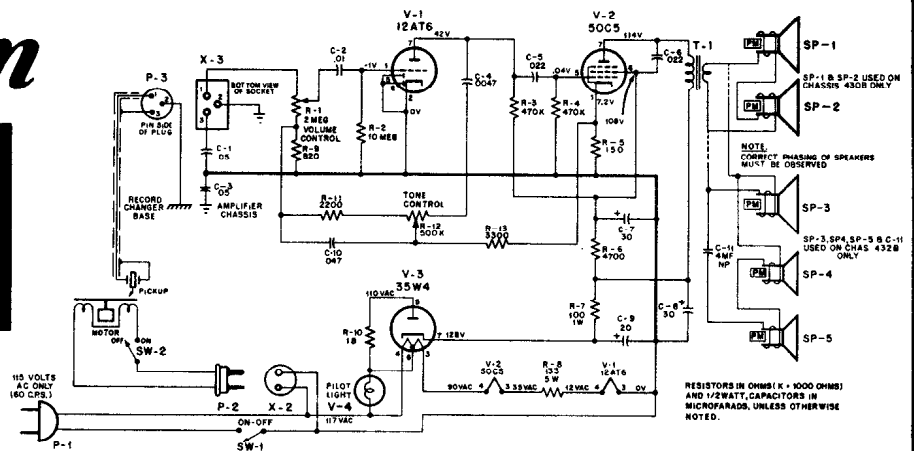

Emerson

Model 891B, Chassis 120399B

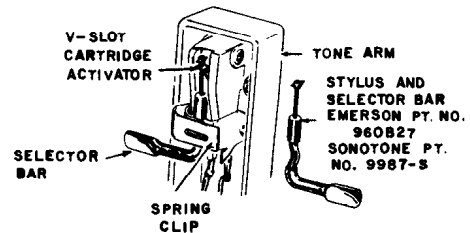
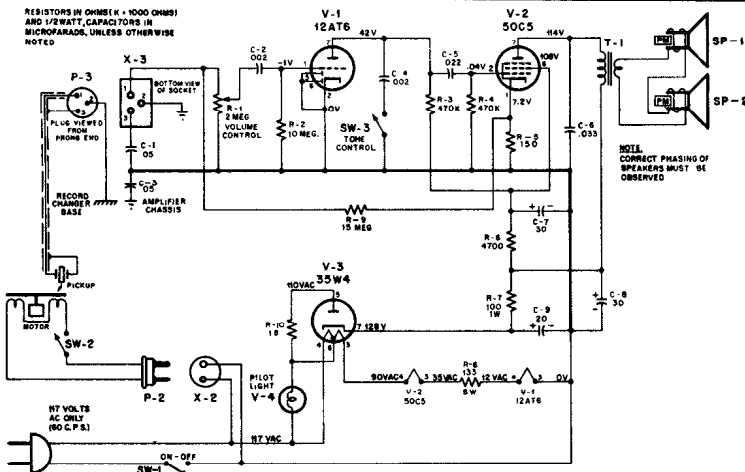

TO REPLACE STYLUS AND SELECTOR BAR

For best operation and record tracking, it is recommended that the stylus (needle) and selector bar (flip-over arm) be replaced as a single unit. To change this unit, proceed as follows:

1. Lift up tone arm.
2. With one hand, hold spring clip in a direction away from tone arm.
3. With other hand, slide out selector bar and stylus as shown in diagram.
4. To replace new stylus and selector bar, reverse above procedure.

1. Voltages indicated are positive d.c., resistances in ohms, unless otherwise indicated.
2. Measurements made with voltohmmyst or equivalent.
3. All measurements taken from pin to B neutral unless otherwise indicated.
4. Voltage measurements taken with:
 - a) Line voltage maintained at 117 volts a.c. only.
 - b) Volume control set for maximum volume.
 - c) Phono plugs disconnected.
5. Resistance measurements taken with:
 - a) Power line cord disconnected from outlet.
 - b) Volume control set for maximum volume.
 - c) Phono plugs disconnected.
6. Nominal tolerance on component values make possible a variation of $\pm 15\%$ in voltage and resistance readings.

Emerson Radio

MODEL 888
"TRANSTIMER"
CHASSIS 120416

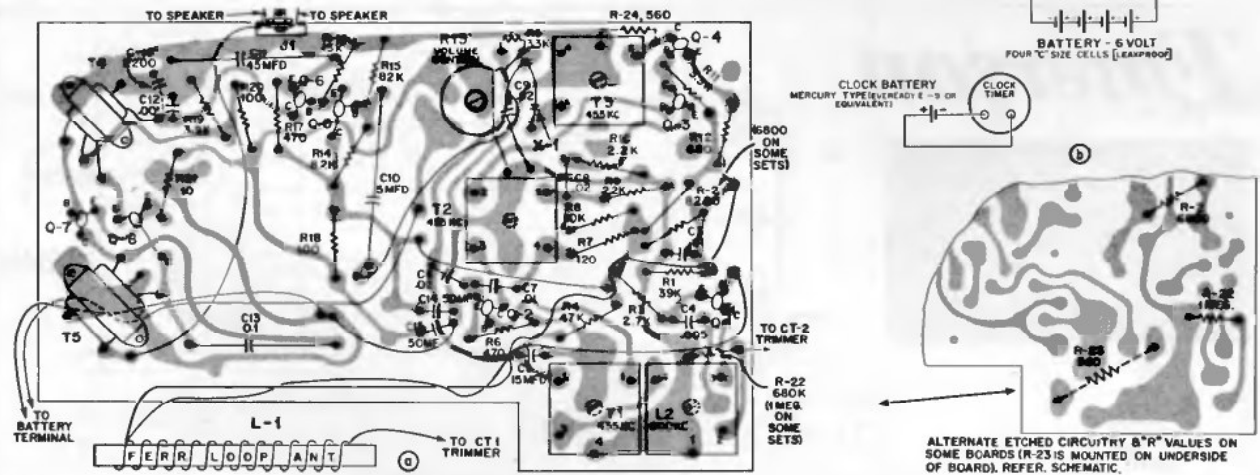
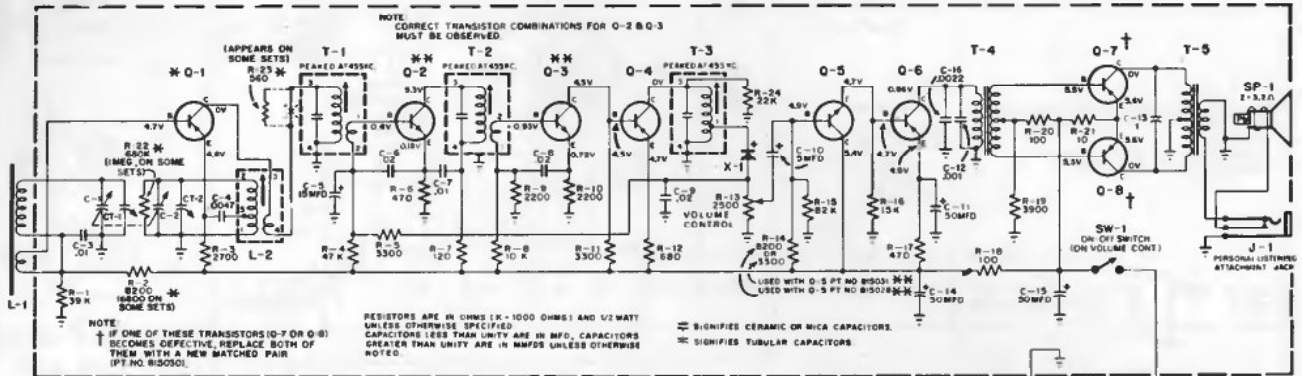

It will be seen from the schematic drawing of the 888 that certain transistors are used in pairs and are associated with specific resistors. Some individual transistors must likewise be used with specific resistors. Because of the small physical size of the transistors, the 1st three digits, "815", have been replaced by the letter, "E"

| TRANSISTOR PAIRS | | ASSOCIATED | TRANSISTOR PAIRS | | ASSOCIATED | TRANSISTOR | ASSOCIATED | TRANSISTOR | ASSOCIATED |
|------------------|---------|------------|------------------|---------|------------|------------|------------|------------|------------|
| Q2 | Q3 | R12 | Q2 | Q3 | R12 | Q5 | R14 | Q5 | R14 |
| 815026C | 815026A | 680 | 815026C | 815026E | 680 | 815031 | 3800 | 815033 | 6800 |
| 815026B | 815026B | 680 | 815026D | 815026D | 680 | 815028 | 8200 | 815034 | 8200 |
| 815026B | 815026D | 680 | 815026C | 815026F | 330 | 815032 | 4700 | 815035 | 10,000 |

| TRANSISTOR SUBSTITUTES | | TRANSISTOR NOS. |
|------------------------|-----------|-----------------|
| FDR | USE | NOS. |
| 815026B | 815026D | Q2/Q3 |
| 815026A | 815026E | Q2/Q3 |
| 815026C | No Subst. | Q2/Q3 |

| TRANSISTOR SUBSTITUTES | | TRANSISTOR NOS. |
|------------------------|------------|-----------------|
| FOR | USE | NOS. |
| 815026F | No. Subst. | Q2/Q3 |
| 815028 | 815032 | Q5 |
| 815031 | 815032 | Q5 |

| TRANSISTOR SUBSTITUTES | | TRANSISTOR NOS. |
|------------------------|--------|-----------------|
| FOR | USE | NOS. |
| 815033 | 815032 | Q5 |
| 815034 | 815032 | Q5 |
| 815035 | 815032 | Q5 |

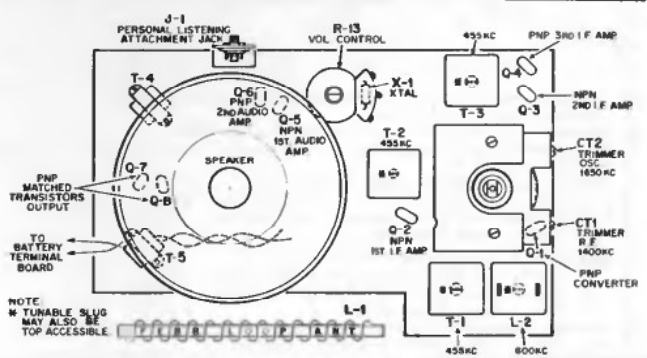
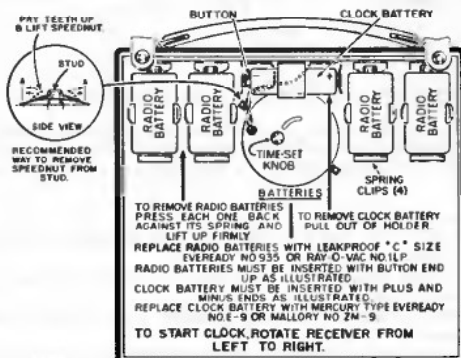

Emerson Radio

Model 895B, Chassis 120431B

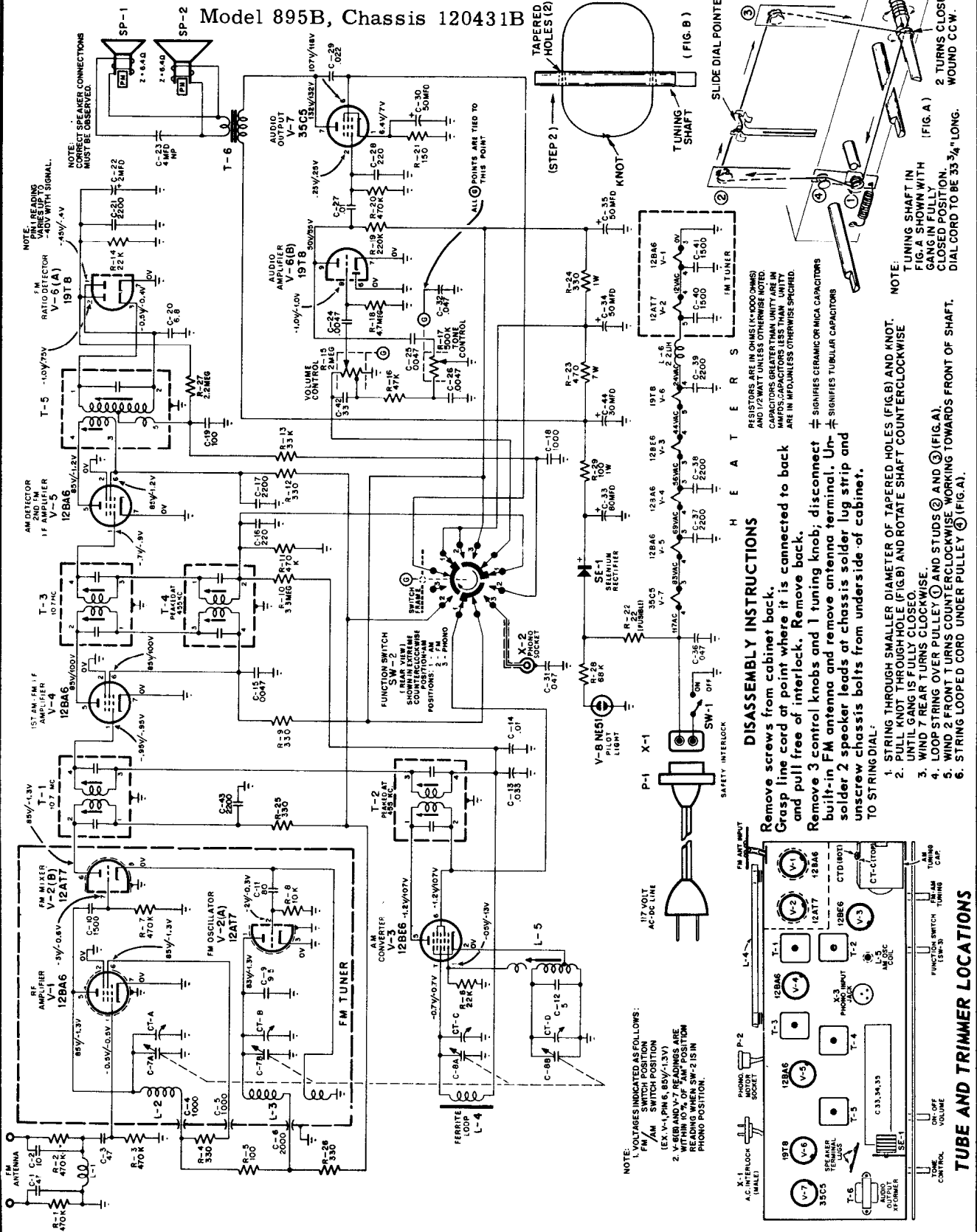

NOTE: PHIL READING -40V WITH SIGNAL. -45V/.4V

NOTE: CORRECT SPEAKER CONNECTIONS MUST BE OBSERVED.

ALL @ POINTS ARE TIED TO THIS POINT

RESISTORS ARE IN OHMS (K=1000 OHMS) UNLESS NOTED. CAPACITORS GREATER THAN 1000 μF ARE IN MFD. CAPACITORS LESS THAN 100 μF ARE IN PFD. UNLESS OTHERWISE SPECIFIED.

⊕ SIGNIFIES CERAMIC OR MICA CAPACITORS
⊕ SIGNIFIES TUBULAR CAPACITORS

DISASSEMBLY INSTRUCTIONS

- Remove screws from cabinet back. Grasp line cord at point where it is connected to back and pull free of interlock. Remove back. Remove 3 control knobs and 1 tuning knob; disconnect built-in FM antenna and remove antenna terminal. Unsolder 2 speaker leads at chassis solder lug strip and unscrew chassis bolts from underside of cabinet. TO STRING DIAL:
1. STRING THROUGH SMALLER DIAMETER OF TAPERED HOLES (FIG. B) AND KNOT.
 2. PULL KNOT THROUGH HOLE (FIG. B) AND ROTATE SHAFT COUNTERCLOCKWISE UNTIL GANG IS FULLY CLOSED.
 3. WIND 7 REAR TURNS CLOCKWISE.
 4. LOOP STRING OVER PULLEY ① AND STUDS ② AND ③ (FIG. A).
 5. WIND 2 FRONT TURNS COUNTERCLOCKWISE WORKING TOWARDS FRONT OF SHAFT.
 6. STRING LOOPED CORD UNDER PULLEY ④ (FIG. A).

NOTE: TUNING SHAFT IN FIG. A SHOWN WITH GANG IN FULLY CLOSED POSITION. 2 TURNS CLOSERLY WOUND CCW. 7 TURNS CLOSERLY WOUND CLOCKWISE.

NOTE: 1. VOLTAGES INDICATED AS FOLLOWS: FM AM SW-1 POSITION (EX. V-1 PH & 85V/.13V) 2. V-6 AND V-7 READINGS ARE WITHIN 10% OF "AM" POSITION READINGS WHEN SW-2 IS IN PHONO POSITION.

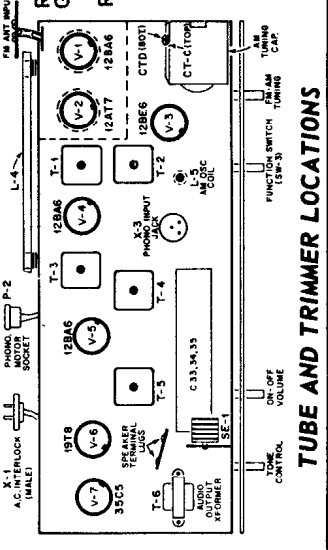

VOLUME R-19, MOST-OFTEN-NEEDED 1959 RADIO SERVICING INFORMATION
 EMERSON RADIO Model 999, Chassis 120433B, and Model 999R, Chassis 120433R

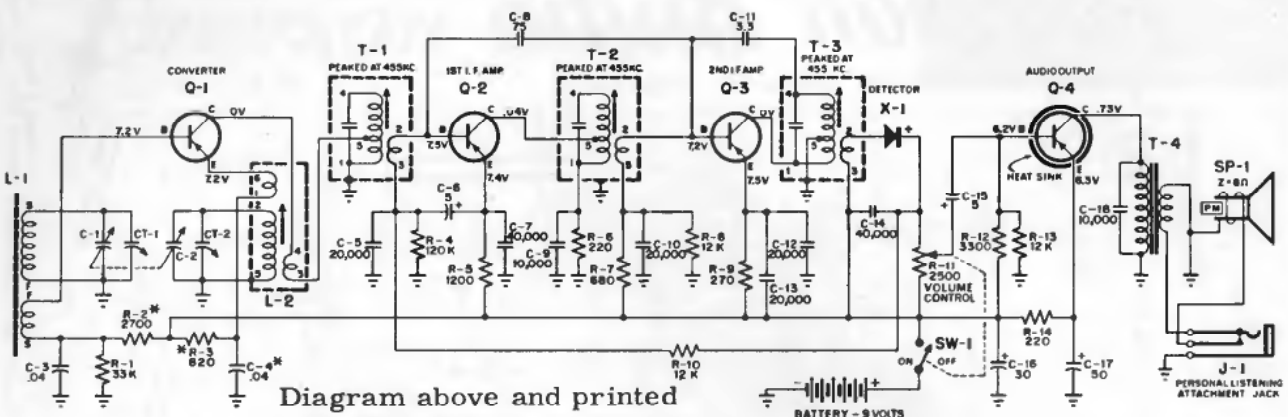
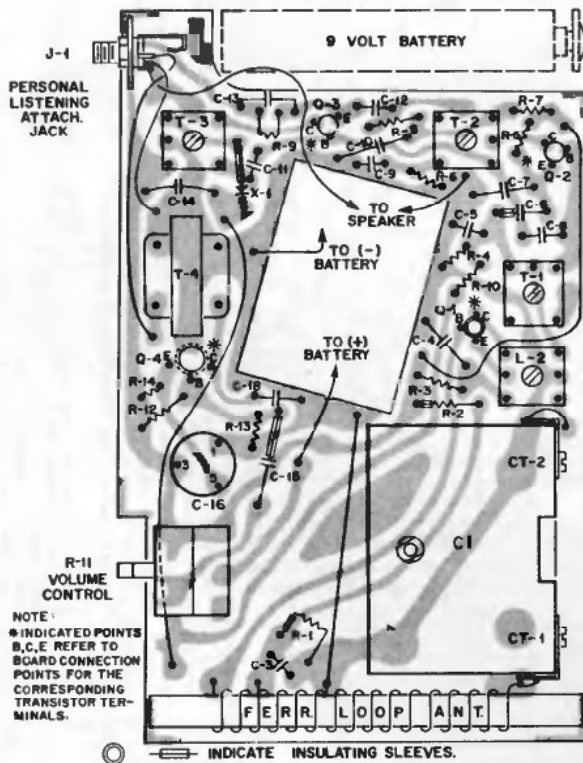
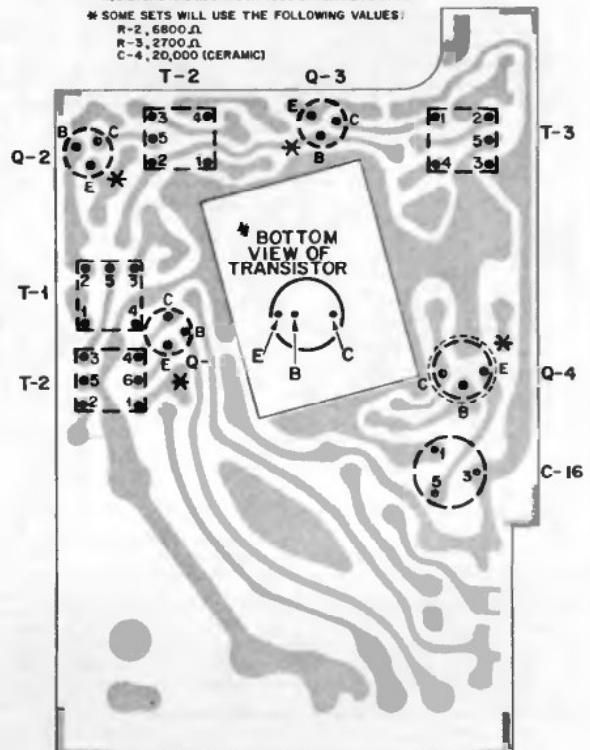

Diagram above and printed circuits below are exact for Chassis 120433B, Model 999.

- NOTES:
 * SIGNIFIES CERAMIC OR MICA CAPACITORS, CAPACITY IN MICRO-MICROFARADS.
 † SIGNIFIES TUBULAR CAPACITORS, CAPACITY IN MICROFARADS.
 RESISTORS ARE IN OHMS (K=1000 OHMS) AND 1/2 WATT.
 * SOME SETS WILL USE THE FOLLOWING VALUES:
 R-2, 6800 Ω
 R-3, 2700 Ω
 C-4, 20,000 (CERAMIC)



PRINTED CIRCUIT CHASSIS DIAGRAM (TOP VIEW)



PRINTED CIRCUIT CHASSIS DIAGRAM (BOTTOM VIEW)

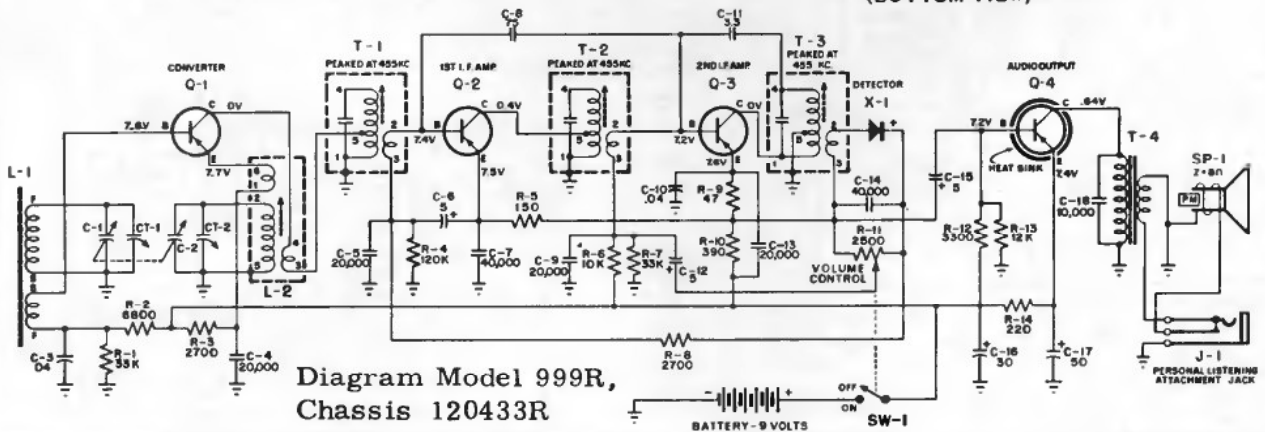
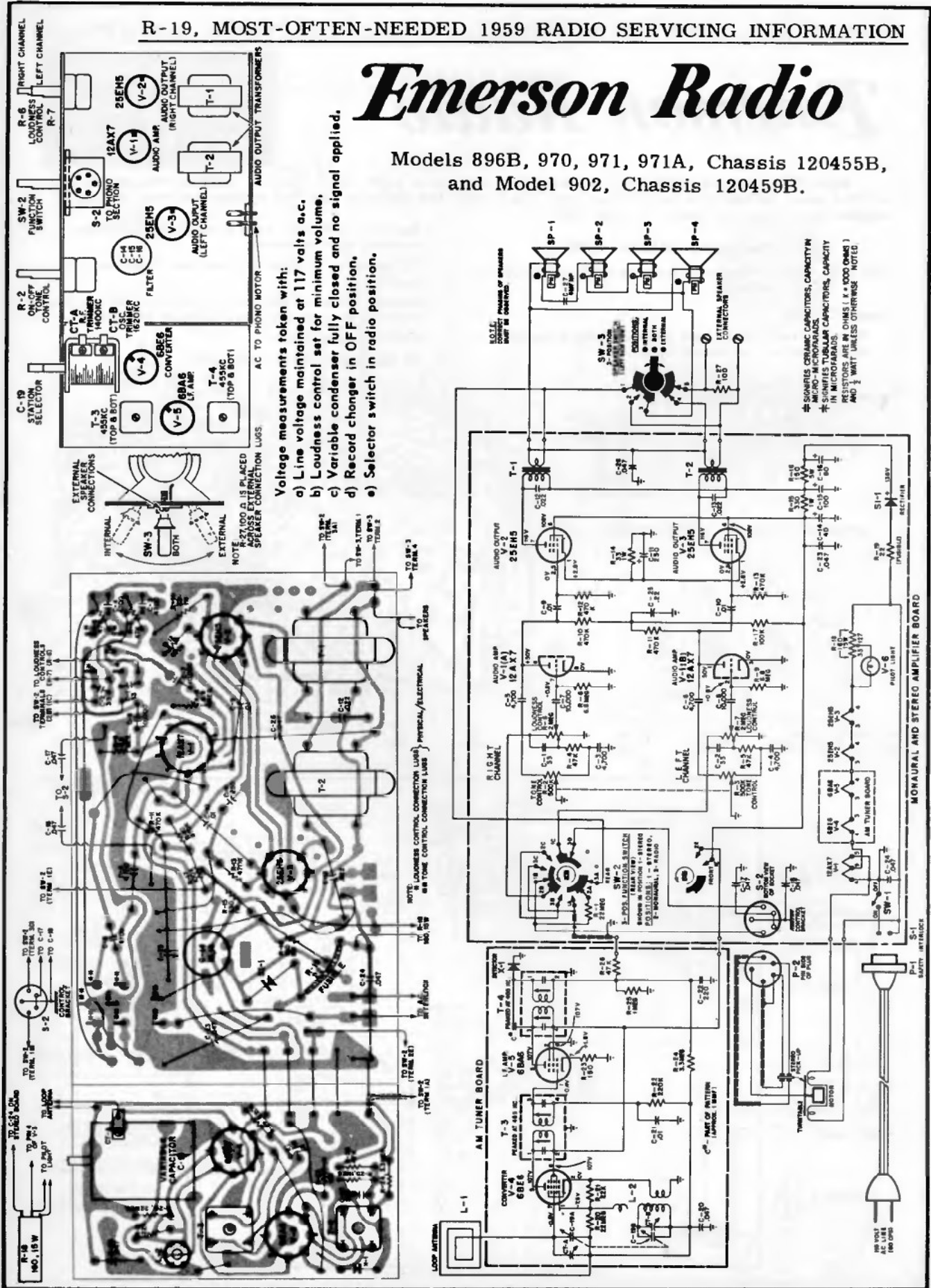

Diagram Model 999R, Chassis 120433R

Emerson Radio

Models 896B, 970, 971, 971A, Chassis 120455B,
and Model 902, Chassis 120459B.



GENERAL ELECTRIC COMPANY

MODEL S
T105A
T106A,B
T107B

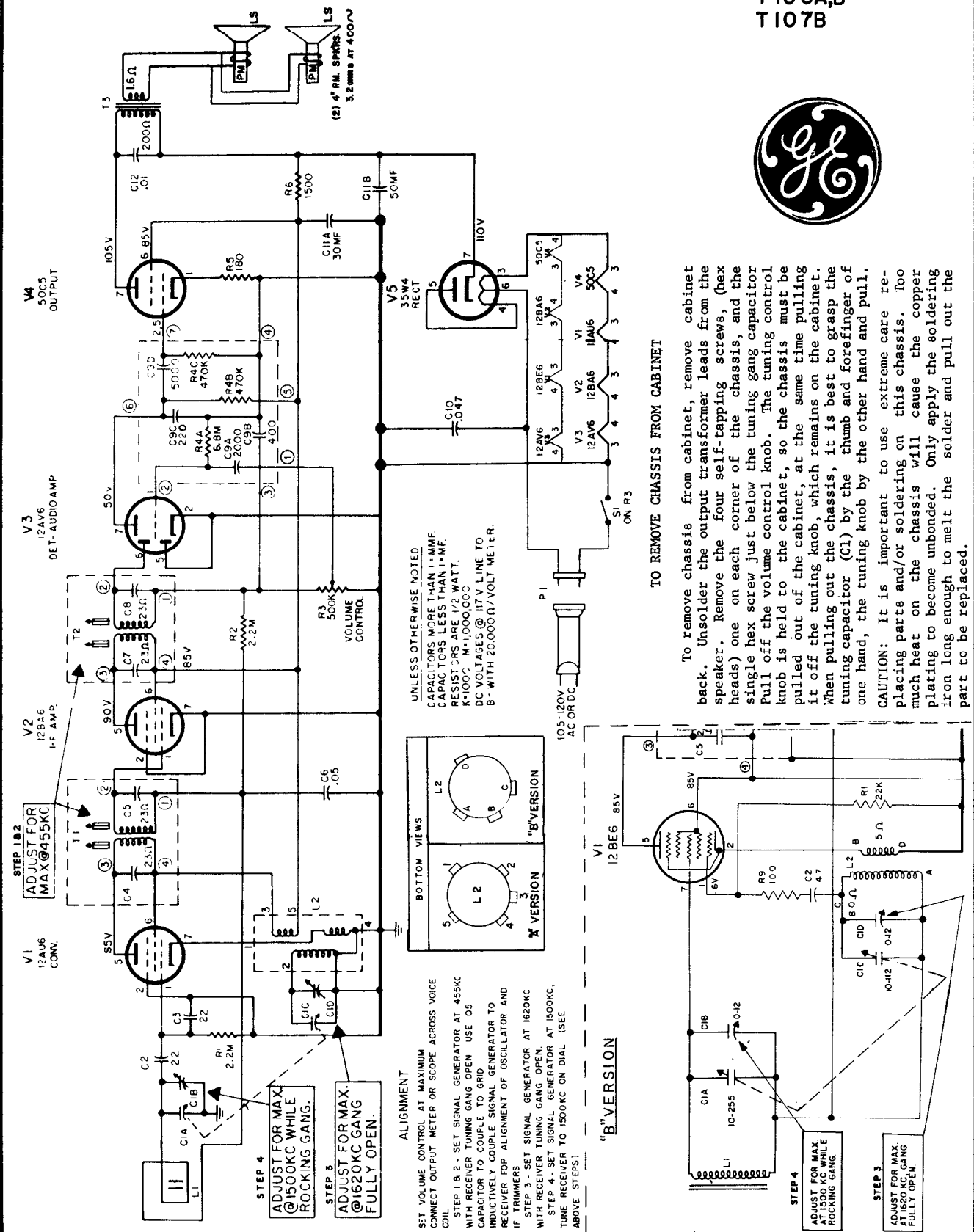

GENERAL ELECTRIC

MODELS
TII5A
TII6A

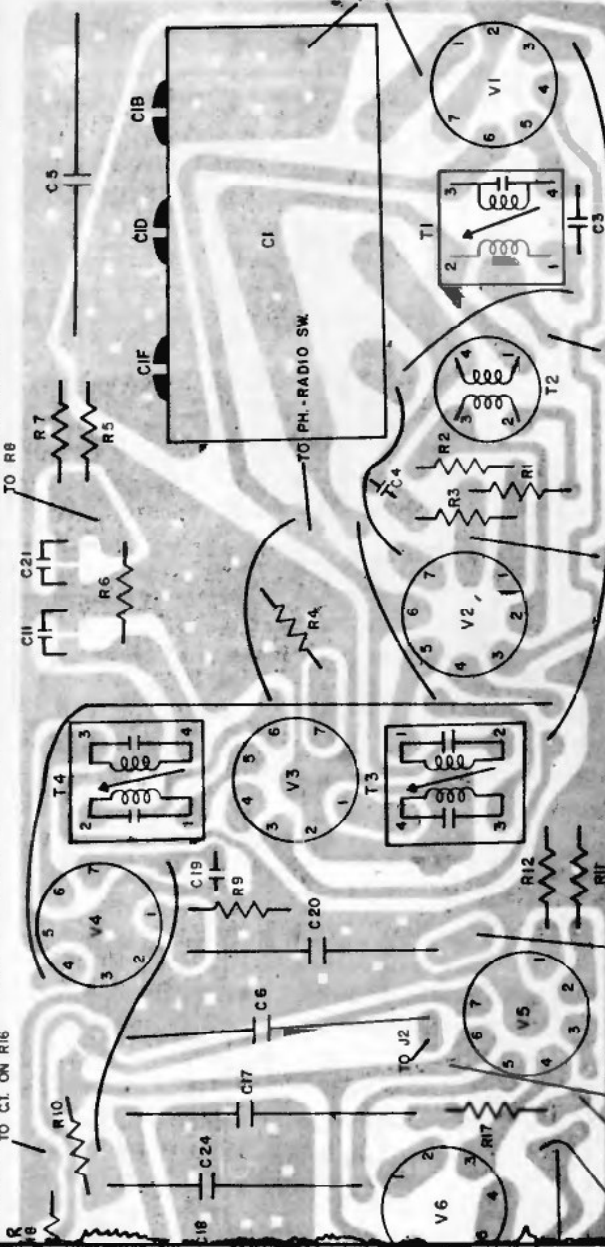
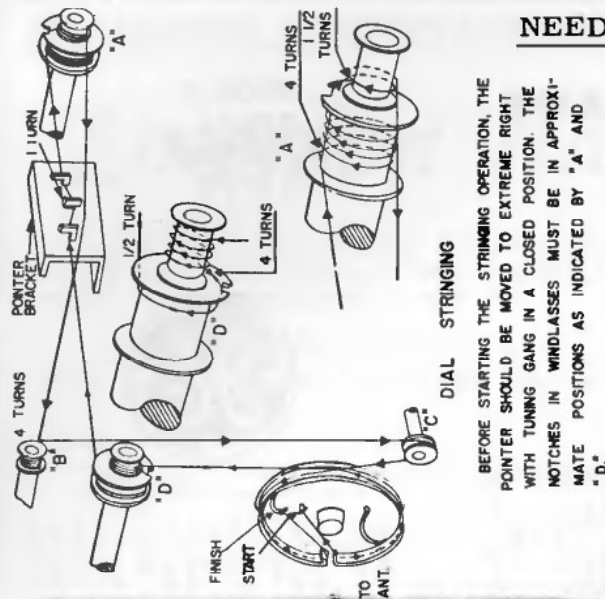

GENERAL ELECTRIC COMPANY

Models T125A, T126A, T127A

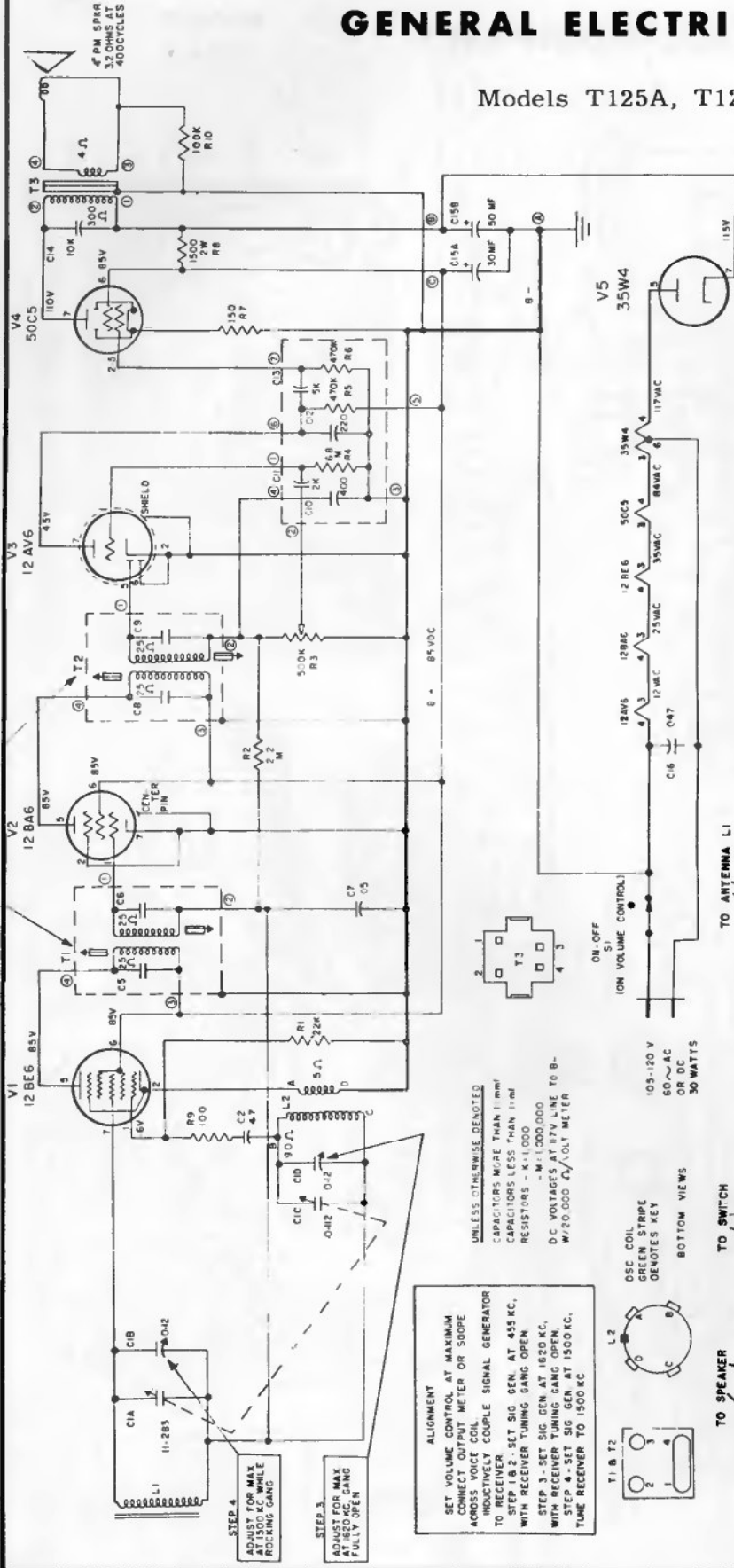

TO REMOVE CHASSIS FROM CABINET:

After removing cabinet back remove the screw on the cabinet bottom that holds the chassis board support. The tuning knob is a captive knob and remains in the cabinet front. Close the tuning gang to prevent any possible damage to the plates. Slide one hand under the printed chassis board placing the fingers over the front edge. Slide the board back out of the grooves on either end simultaneously removing the tuning gang shaft from the tuning knob. When replacing the chassis, close the tuning gang and line the flat side of the tuning gang shaft up with the flat in the tuning knob. Place the ends of the board in the grooves and push on the edge of the board, not on the components. The tuning shaft will enter the tuning knob and the front edge of the board will seat itself in the grooved bosses inside the cabinet front. Replace the board support and self-tapping screw.

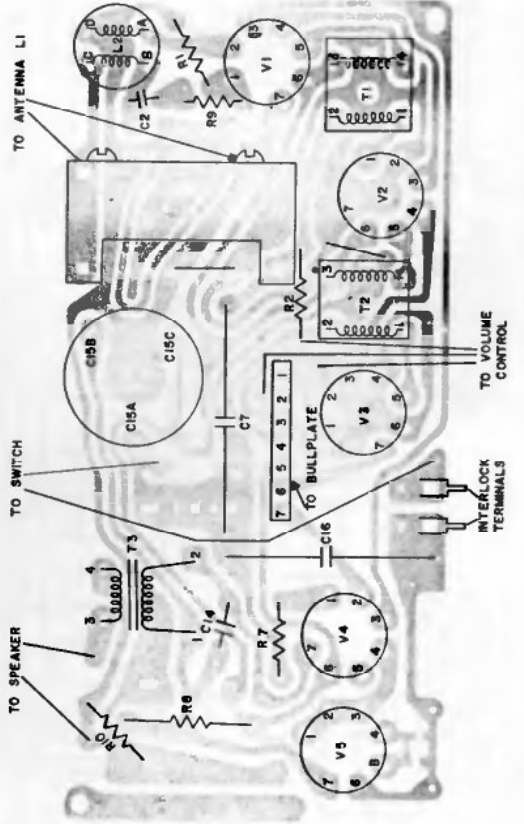

GENERAL ELECTRIC COMPANY

Models T130A, B, T131A, B, T132A, B

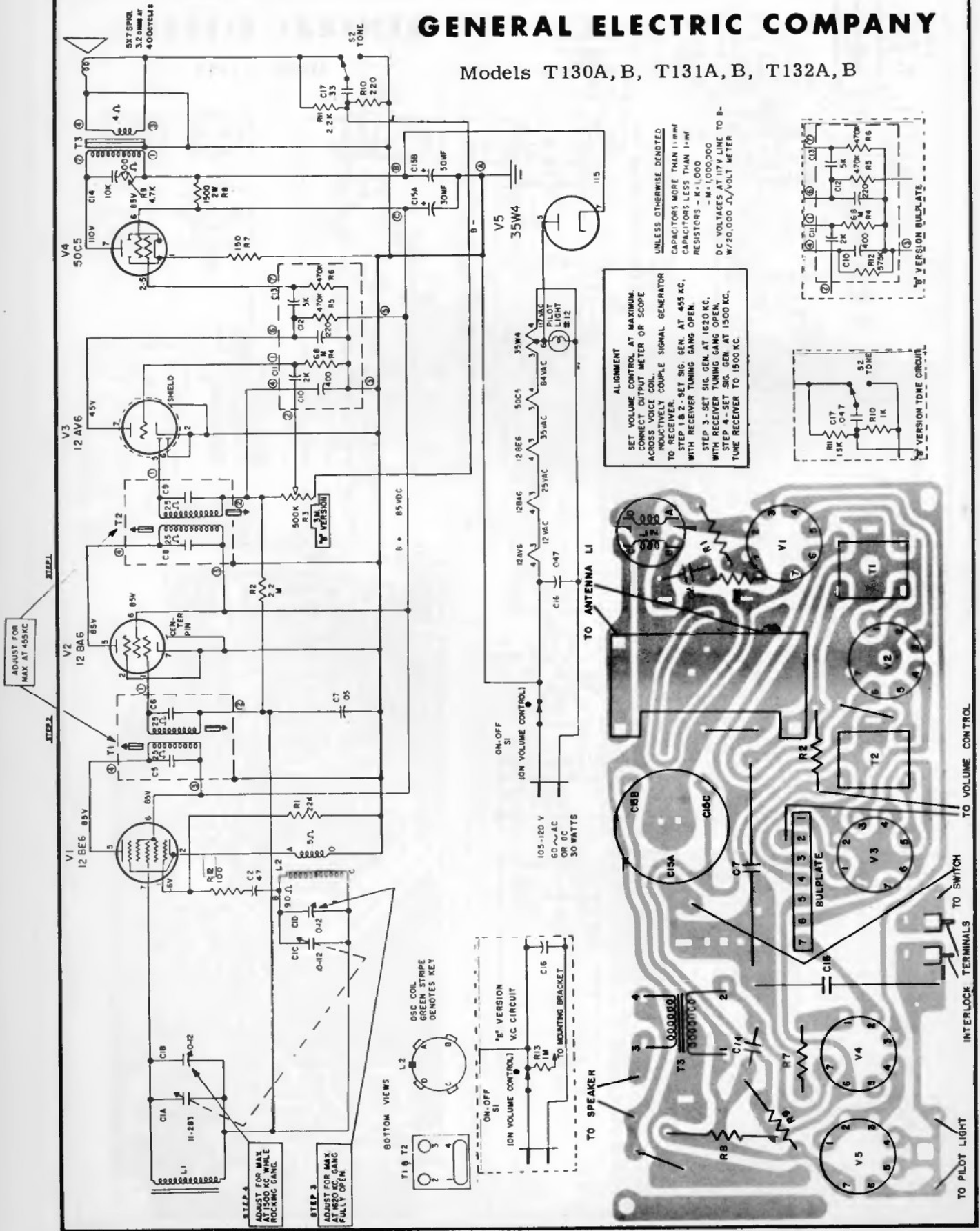

GENERAL ELECTRIC

Model T135A

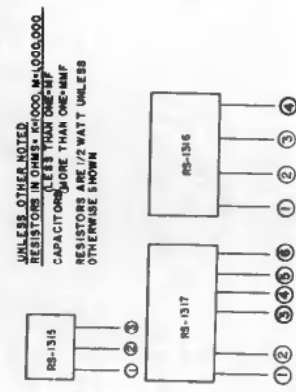
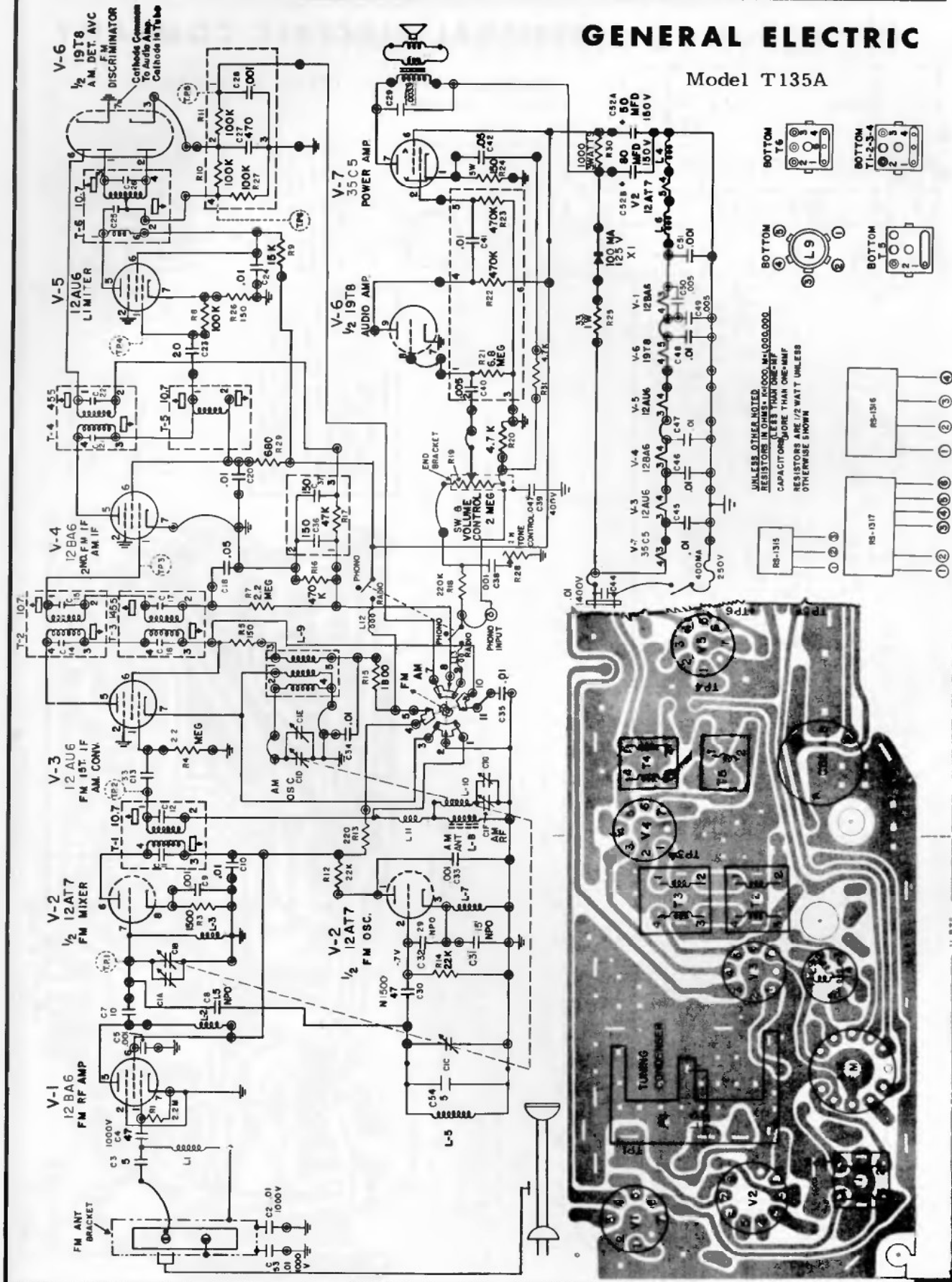

GENERAL ELECTRIC

Model T210A

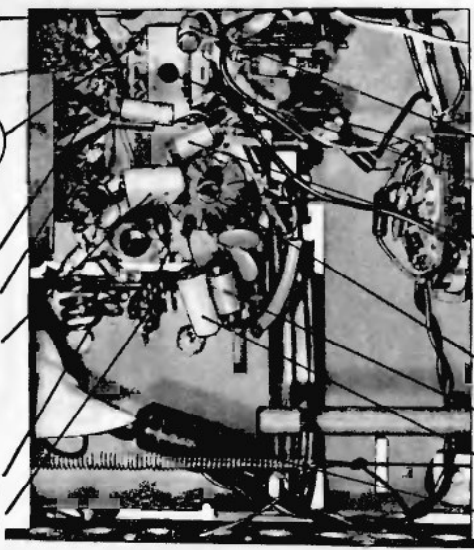
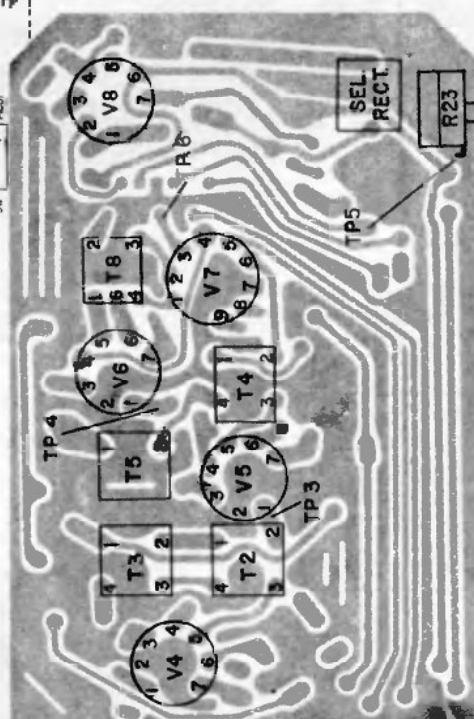
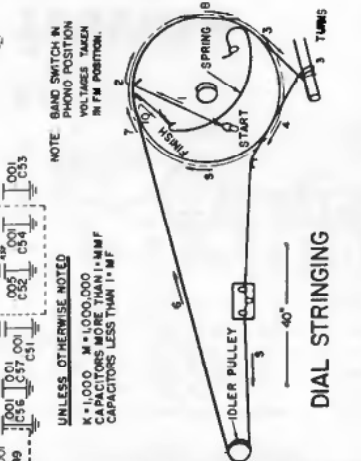
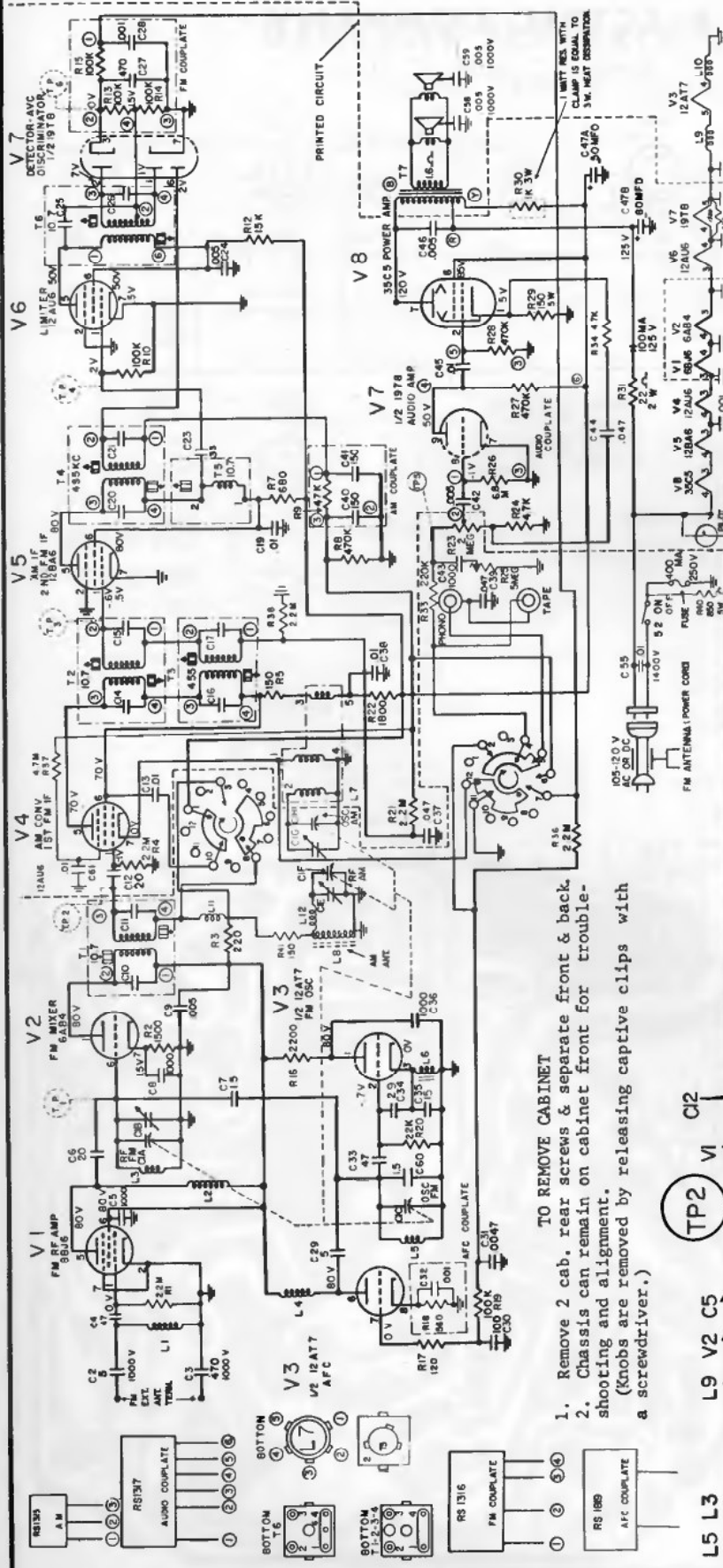

- TO REMOVE CABINET
1. Remove 2 cab. rear screws & separate front & back.
 2. Chassis can remain on cabinet front for troubleshooting and alignment.
(Knobs are removed by releasing captive clips with a screwdriver.)

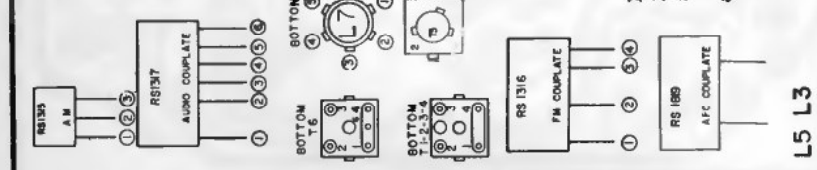

BOTTOM VIEW

GENERAL ELECTRIC COMPANY

Models C-400A, C-401A

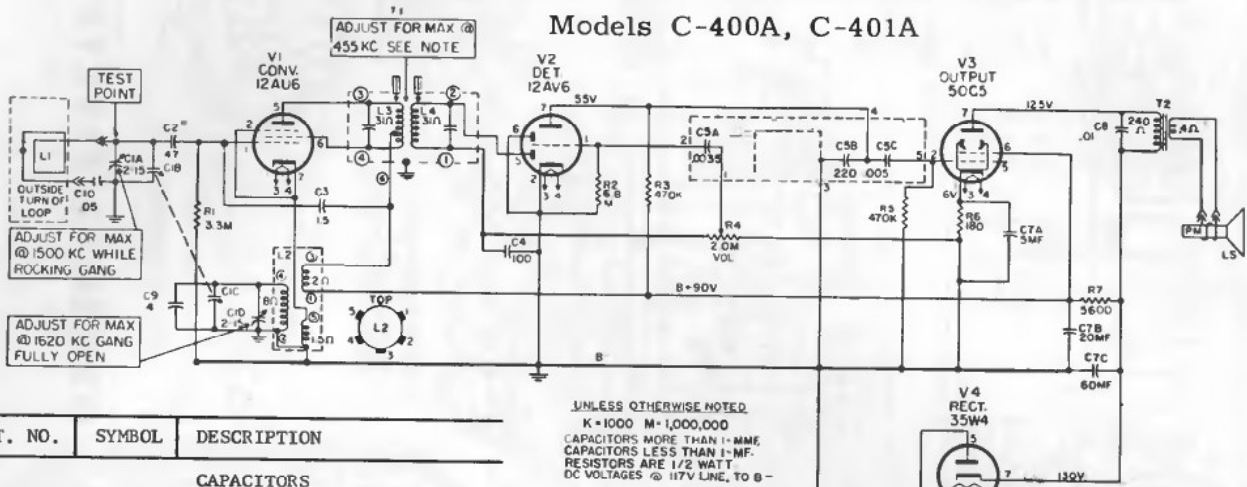

UNLESS OTHERWISE NOTED
 K = 1000 M = 1,000,000
 CAPACITORS MORE THAN 1-MF.
 CAPACITORS LESS THAN 1-MF.
 RESISTORS ARE 1/2 WATT
 DC VOLTAGES @ 117V LINE, TO B -

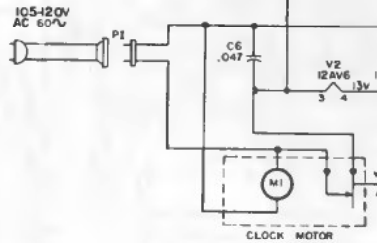

ALIGNMENT NOTE
 RF

STEP-1 ADJUST C1D
 STEP-2 ADJUST C1A
 STEP-3 READJUST C1D
 IF INPUT SIGNAL TO TEST POINT
 STEP-1 ADJUST L4.
 STEP-2 ADJUST L3.

| CAT. NO. | SYMBOL | DESCRIPTION |
|----------------------|----------------|---|
| CAPACITORS | | |
| RCE-217 | C7A, B, C | 5mf., @25V., 20mf., & 60mf., @150V., Electro..... |
| RCN-048 | C3 C6 | 1.5mmf., 20%, 500V., Ceramic .047mf., +40-10%, 600V., Molded..... |
| RCT-097 | C1A, B C, D | Tuning Capacitor, Two Gang |
| RCW-3036 | C5A, B, C | .0035mf., 220mf., .005mf. Bullplate..... |
| RCW-3079 | C4 | 100mmf., 20%, 500V., Ceramic |
| RCW-3209 | C9 | 4mmf., ±20%, 500V., Ceramic. |
| RS-1022 | | .01mf., +40-10%, 400V. Ceramic |
| POTENTIOMETERS | | |
| RS-1028 | R4 | Volume Control 2 meg..... |
| COILS & TRANSFORMERS | | |
| RLC-135 | L2 | Oscillator Coil C400..... |
| RS-1414 | L2 | Oscillator Coil C401..... |
| RS-1027 | T1 | I.F. Trans. C400-C401..... |
| RT0-176 | T2 | Output Trans. C400-C401.. |

TO REMOVE CHASSIS FROM CABINET:

Remove cabinet back and interlock. Remove the five self-tapping screws (hex heads), one on each corner of the chassis, and the single hex screw just below the tuning gang capacitor. Pull off the volume control knob.

The tuning control knob is a captive knob which remains with the cabinet. The chassis must be pulled out of the cabinet and separated from the tuning knob simultaneously. When pulling out the chassis, first close the tuning capacitor, grasp the tuning capacitor with the thumb and forefinger of one hand and the tuning knob with the other and pull the chassis out of the cabinet.

CAUTION:

It is important to use extreme care while replacing parts and or soldering on this chassis. Too much heat on the chassis will cause the copper plating to become unbonded. Only apply the soldering iron long enough to melt the solder and pull out the part to be replaced. A 35 watt soldering iron is recommended.

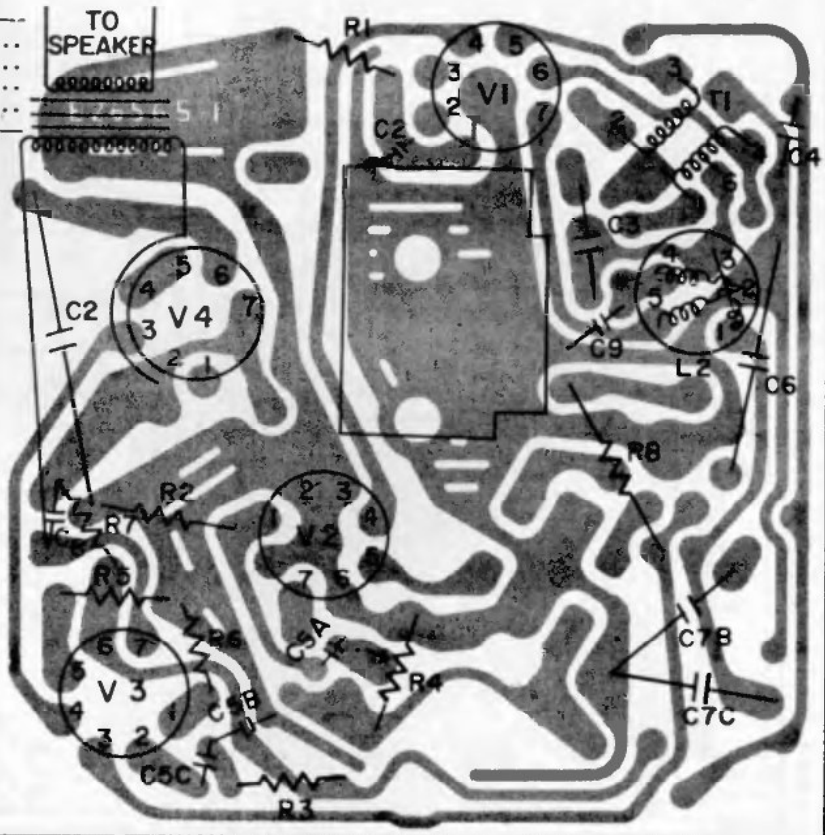

GENERAL ELECTRIC COMPANY

Models C405A,B, C406A,B

SPECIFICATIONS

| | |
|--------------------|--|
| CABINET: | Model C405A,B--Gray and White Model C406A,B--Pink |
| ELECTRICAL RATING: | 105-120 volts AC 30 Watts @117 Volts AC |
| OUTPUT: | Undistorted .9 Watts Maximum 1.5 Watts |

GENERAL INFORMATION

The main difference in the "A" and "B" versions of the C405 series of clock-radios is the oscillator-converter stage (V1). The "A" version uses a 12AU6 tube as V1 and the "B" version uses a 12BE6 as V1. The V1 stage for the "B" version is shown as a separate stage on the schematic.

The tuning knob is held to the cabinet and cannot be removed without first removing the chassis.

SERVICE NOTE

Always use an isolation transformer when servicing or aligning this receiver to protect personnel and test equipment.

When aligning, keep the signal input low so the AVC will not affect the output.

TO REMOVE CABINET FRONT

Remove the two screws located on each side of the cabinet back; unscrew the clock set knob; separate the cabinet front from the back. When separating the cabinet, the speaker leads must be unsoldered before complete separation of the cabinet can be accomplished. The speaker is mounted on the cabinet back with the radio chassis and clock mounted on the cabinet front.

TO REMOVE CHASSIS

Remove the volume control knob. Take out the four hexhead screws, one on each corner of the chassis board and one hexhead screw below the tuning condenser. Unsolder the one wire to switch on the clock and one to the clock motor.

Close the tuning condenser C1, and with the thumb and forefinger grasp the condenser and pull. The chassis will separate from the tuning knob which is left attached to the cabinet front.

TO REMOVE THE CLOCK

Separate the cabinet as described above. Unsolder the two leads, one from the switch to the circuit board and one from the clock motor to the circuit board. Remove the two screws holding the AC interlock to the cabinet. Remove the two clock knobs. Snap out the clock crystal starting from the left side. Then, remove the two nuts holding the clock to the cabinet and remove the clock.

TROUBLESHOOTING

Excessive loudness when adjusting the volume level to minimum is caused by excessive capacity between terminals 2 and 3 of RCW-3207. The excessive capacity can be eliminated without replacing the couplate or by removing the circuit board in the following manner:

1. Clip off couplate lead #3.
2. Solder a 220 mmf. capacitor (Cat. No. RS-1203) across the two outside terminals of the volume control, located on the component side of the chassis board.

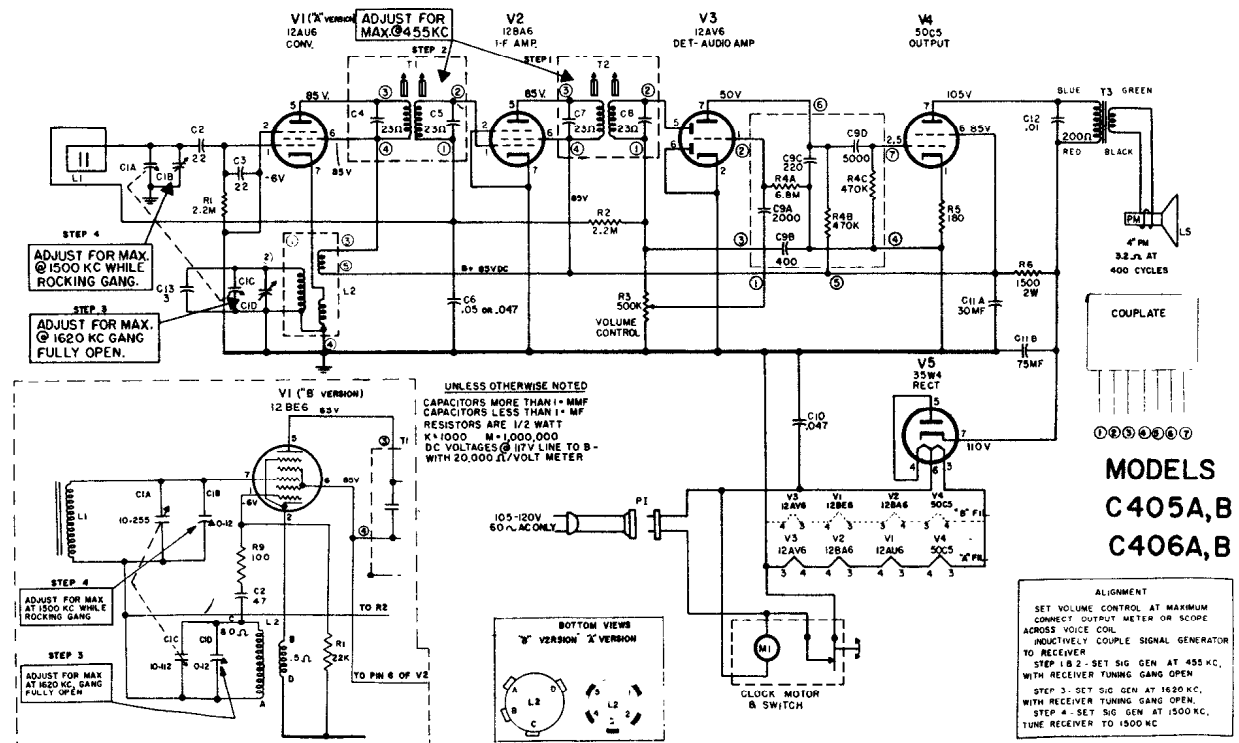

GENERAL ELECTRIC COMPANY

Model C435A

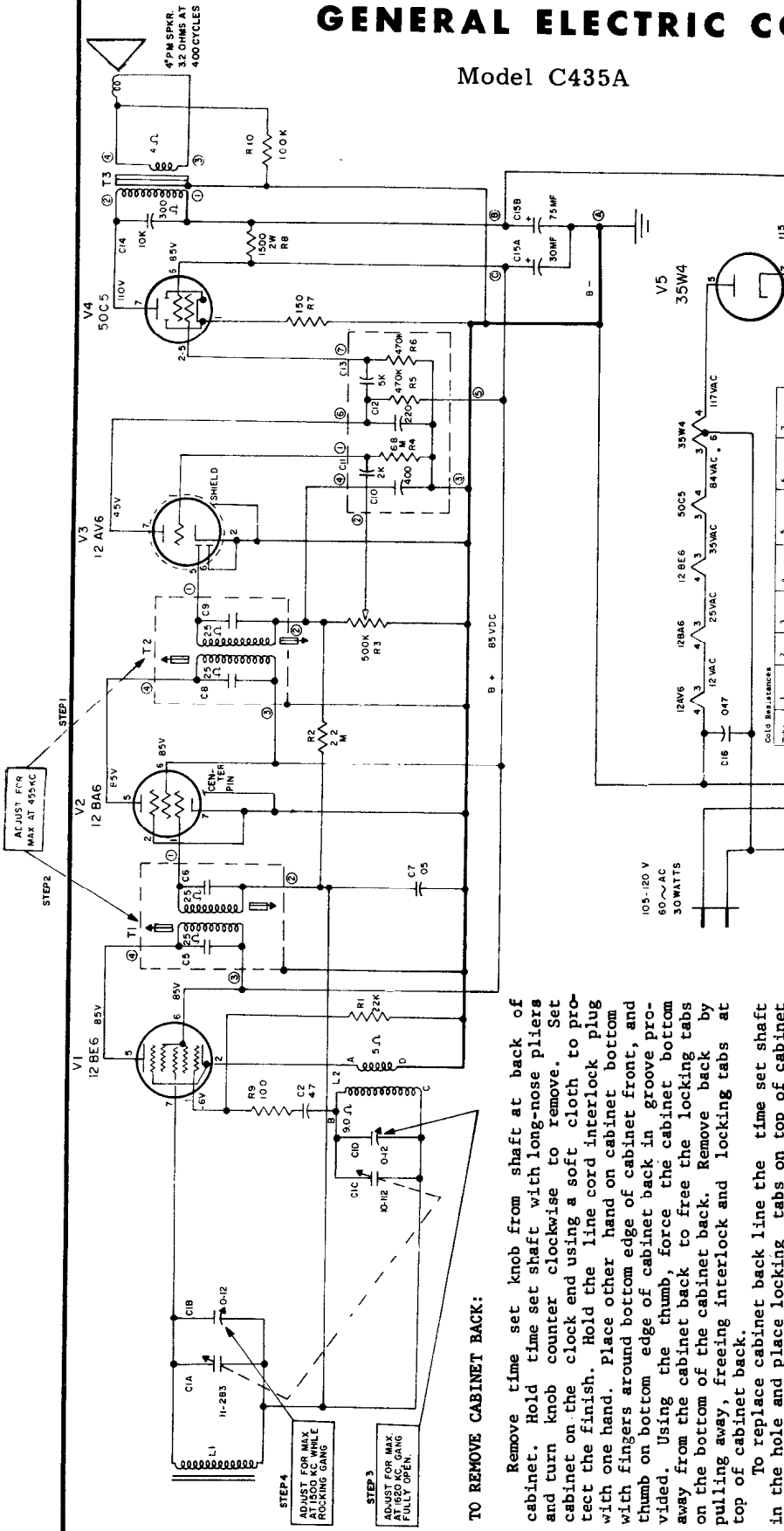

ALIGNMENT
 SET VOLUME CONTROL AT MAXIMUM.
 CONNECT OUTPUT METER OR SCOPE
 TO TUNING GANG AND ADJUST
 INDUCTIVELY COUPLE SIGNAL GENERATOR
 TO RECEIVER.
 STEP 1 & 2 - SET SIG. GEN AT 465 KC,
 WITH RECEIVER TUNING GANG OPEN
 STEP 3 - SET SIG GEN AT 1620 KC,
 WITH RECEIVER TUNING GANG OPEN.
 STEP 4 - SET SIG GEN AT 1500 KC,
 TUNE RECEIVER TO 1500 KC

UNLESS OTHERWISE DENOTED
 CAPACITORS MORE THAN 11 mmf
 CAPACITORS LESS THAN 11 mmf
 RESISTORS - K=1,000
 - M=1,000,000
 DC VOLTAGES AT RTV LINE TO B-
 W/20,000 Ω/VOLT METER

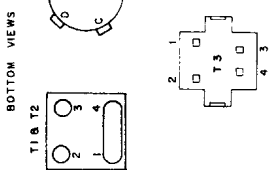

TO REMOVE CABINET BACK:

Remove time set knob from shaft at back of cabinet. Hold time set shaft with long-nose pliers and turn knob counter clockwise to remove. Set cabinet on the clock end using a soft cloth to protect the finish. Hold the line cord interlock plug with one hand. Place other hand on cabinet bottom with fingers around bottom edge of cabinet front, and thumb on bottom edge of cabinet back in groove provided. Using the thumb, force the cabinet bottom away from the cabinet back to free the locking tabs on the bottom of the cabinet back. Remove back by pulling away, freeing interlock and locking tabs at top of cabinet back.

To replace cabinet back line the time set shaft in the hole and place locking tabs on top of cabinet back in slots on cabinet top. Push on bottom of cabinet back sliding the locking tabs up the beveled inclines and snap in slots. Make certain the interlock terminals and plug engage. Replace time set knob by turning clockwise on shaft.

TO REMOVE CHASSIS FROM CABINET:

After removing cabinet back remove the screw on the cabinet bottom that holds the chassis board support. The tuning knob is a captive knob and remains in the cabinet front. Close the tuning gang to prevent any possible damage to the plates. Slide one hand under the printed chassis board placing the fingers over the front edge. Slide the board back out of the grooves on either end simultaneously removing the tuning gang shaft from the tuning knob. When replacing the chassis, close the tuning gang and line the flat side of the tuning gang shaft up with the flat in the tuning knob. Place the ends of the board in the grooves and push on the edge of the board, not on the components. The tuning shaft will enter the tuning knob and the front edge of the

board will seat itself in the grooved bosses inside the cabinet front. Replace the board support and self-capping screw.

TO REMOVE VOLUME CONTROL:

The volume control is attached to the cabinet and may be removed by pulling the knob straight off and removing the palmnut. When replacing the volume control place the tab on the control in the groove provided.

TO REMOVE SPEAKER:

After removing the chassis board remove four tubular speaker clips and lift the speaker out of the cabinet.

COLD Resistances

| Tube | 1 | 2 | 3 | 4 | 5 | 6 | 7 |
|-------|--------|-----|-------|--------|----------|----------|------------|
| 12AV6 | 6.8K | 0 | 12ohm | 0 | 50K | 0 | 470K |
| 12BA6 | 2.7K | 0 | 25ohm | 120ohm | *1500ohm | *1500ohm | 0 |
| 12BE6 | 22K | 0 | 36ohm | 75ohm | *1500ohm | 2.7K | 0 |
| 50C5 | 100ohm | 47K | 35ohm | 45ohm | 47K | *1500ohm | *500ohm |
| 35W4 | TP | TP | 85ohm | 115ohm | 115ohm | 100ohm | 22K (Min.) |

TP- The Pilot
 * - Measured from Pin 7 of V5
 All measurements made with switch S1 open



GENERAL ELECTRIC COMPANY

Models C440A and C441A

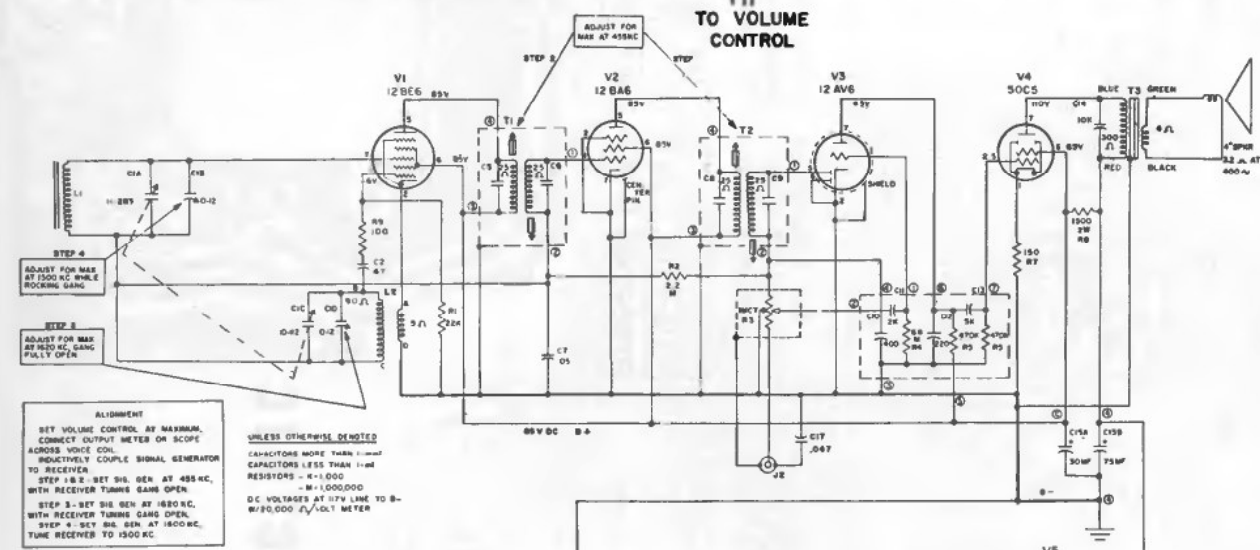
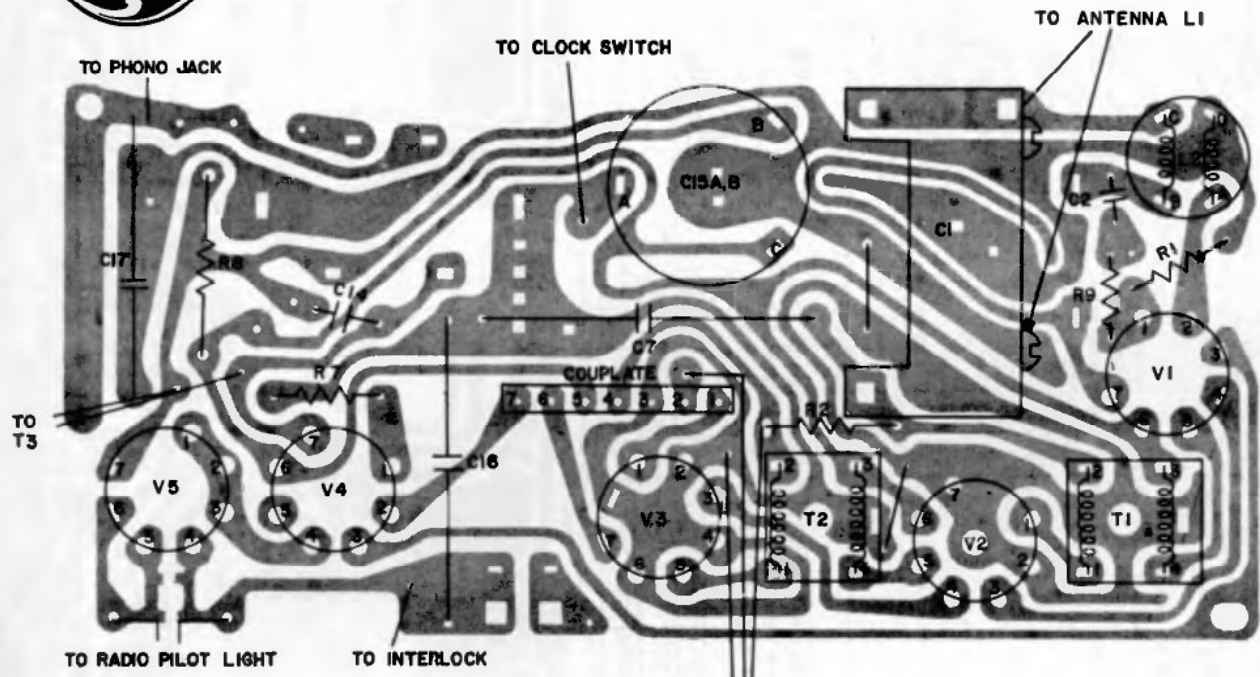

ALIGNMENT
 SET VOLUME CONTROL AT MAXIMUM. CONNECT OUTPUT METER OR SCOPE ACROSS VOICE COIL. INDUCTIVELY COUPLE SIGNAL GENERATOR TO RECEIVER.
STEP 1 - SET SIG. GEN. AT 455 KC. WITH RECEIVER TUNING GANG OPEN.
STEP 2 - SET SIG. GEN. AT 1680 KC. WITH RECEIVER TUNING GANG OPEN.
STEP 3 - SET SIG. GEN. AT 1680 KC. WITH RECEIVER TUNING GANG OPEN.
STEP 4 - SET SIG. GEN. AT 1680 KC. TUNE RECEIVER TO 1500 KC.

UNLESS OTHERWISE DESIGNATED
 CAPACITORS MORE THAN 1 μF
 CAPACITORS LESS THAN 1 μF
 RESISTORS - K = 1,000
 M = 1,000,000
 DC VOLTAGES AT 17V LINE TO B- W/10,000 Ω/10.1 METER

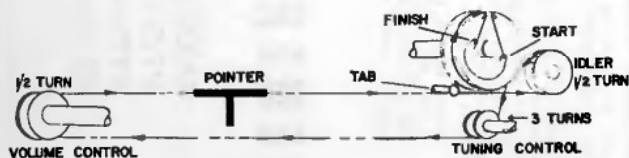
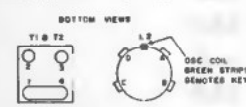

Tube Pin Resistance Chart

| Tube | 1 | 2 | 3 | 4 | 5 | 6 | 7 |
|-------|--------|------|----|-----|----------|----------|------------|
| 12AV6 | 6.8M | 0 | 15 | 0 | 500K | 0 | ≈470K |
| 12BA6 | 2.7M | 0 | 25 | 15 | *1500ohm | *1500ohm | 0 |
| 12BE6 | 22K | 0 | 35 | 25 | *1500ohm | *1500ohm | 2.7M |
| 50C5 | 150ohm | 470K | 35 | 80 | 470K | *1500ohm | *300ohm |
| 35W4 | TP | TP | 80 | 110 | 105 | 105 | 20% (min.) |

TP-Tie Point
 * Measure from Pin 7 of V5
 Resistances measured with pilot light (Mezco # 12) in socket
 All measurements taken with respect to B- unless otherwise designated.

GENERAL ELECTRIC

MODELS
P725B
P726B

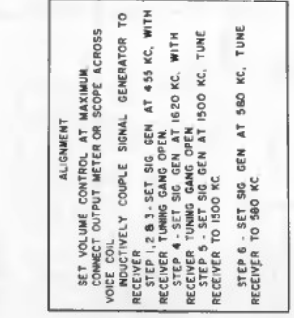
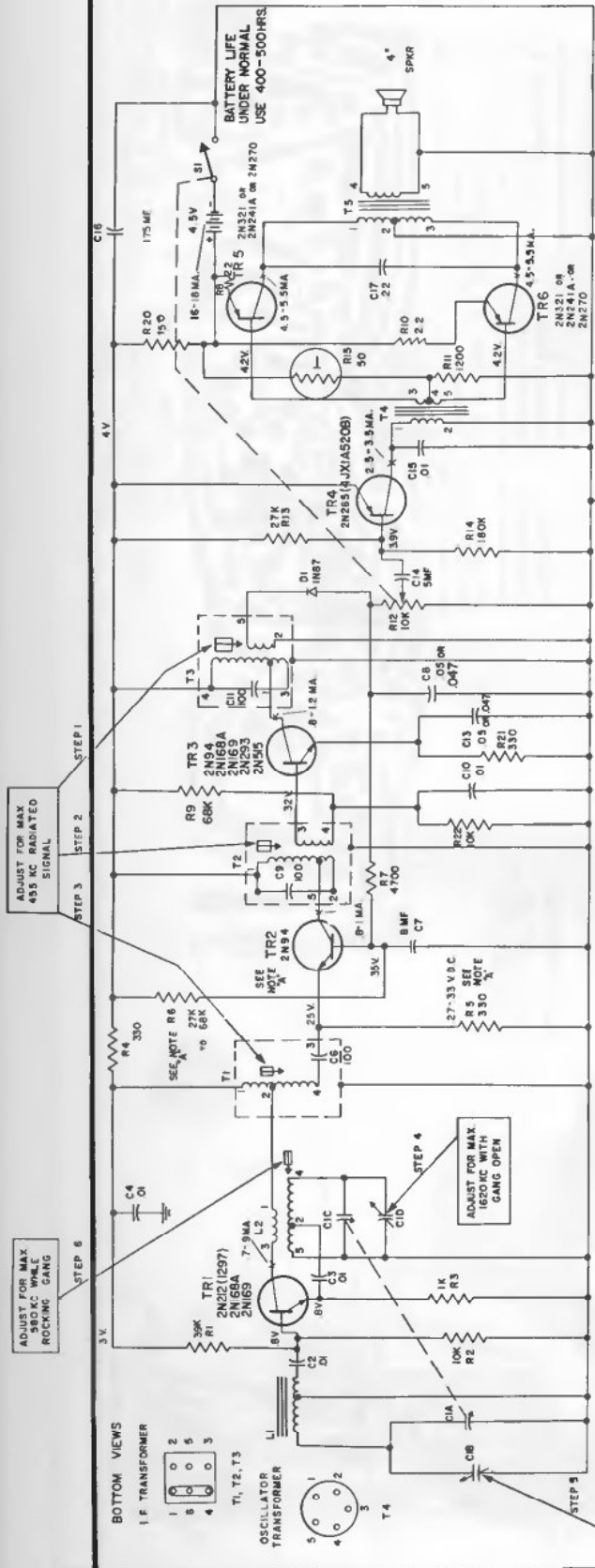

TROUBLESHOOTING

A check of battery condition and total current drain of the receiver should be made first. All current measurements are made at quiescence with the receiver turned on, volume control at maximum, tuning gang closed, and with no signal conditions. The total receiver current drain is 16 to 18 mls. This is measured by inserting a milliammeter in series with the batteries.

If an excessive total current drain is recorded, the individual collector currents of each transistor should be checked. An excessive current reading may mean a shorted transistor; no current will indicate that a transistor or associated circuit component is defective.

A single-edge razor blade is a satisfactory tool for cutting the copper circuit wiring so that a milliammeter can be inserted in series with the break to measure the current flow. After each current check is completed, solder the cut carefully to complete the circuit again.

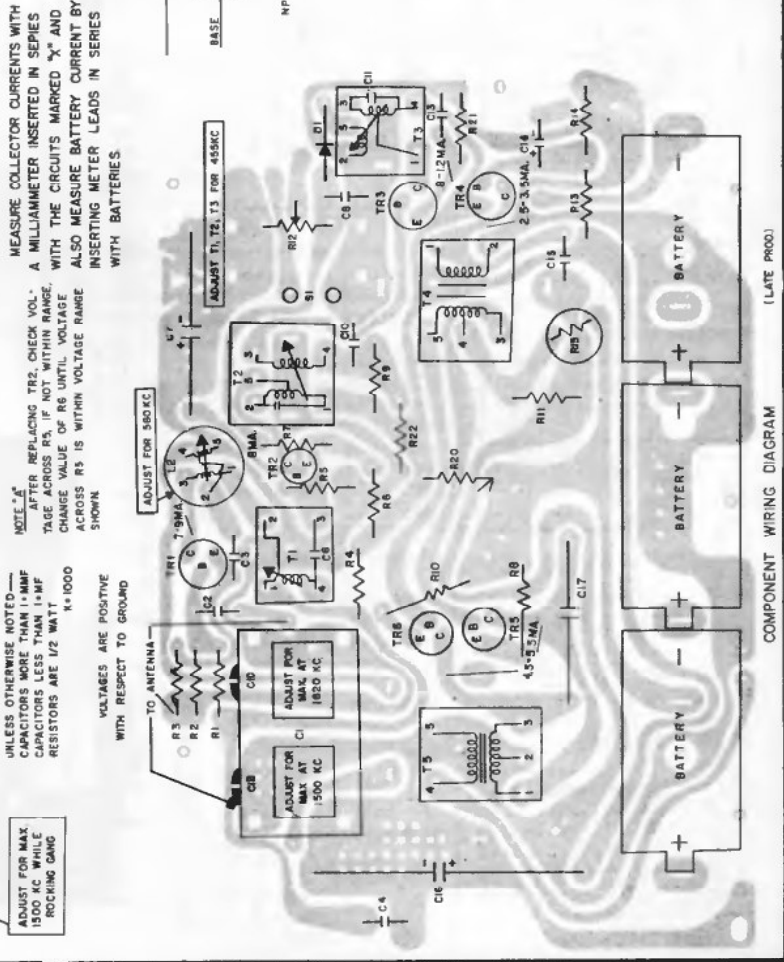

GENERAL ELECTRIC

MODELS
P735A
P736A

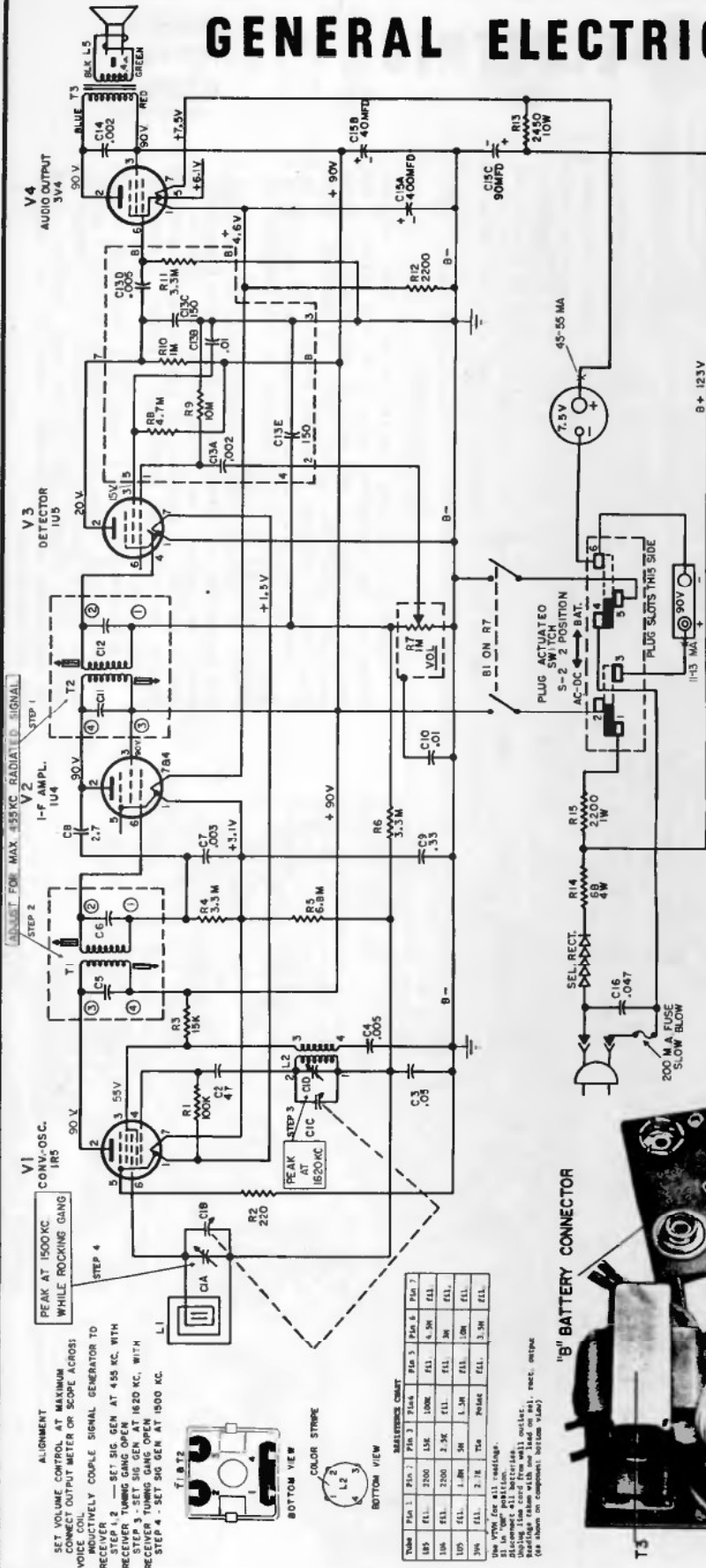

| | | |
|------------------------|---------------------|--------------------|
| OPERATING FREQUENCIES: | Tuning range | 540-1600 KC |
| AUDIO POWER OUTPUT: | I-F Amplifier | 455 KC |
| | Maximum - | 250-300 Milliwatts |
| | 10% distortion | 150 Milliwatts |

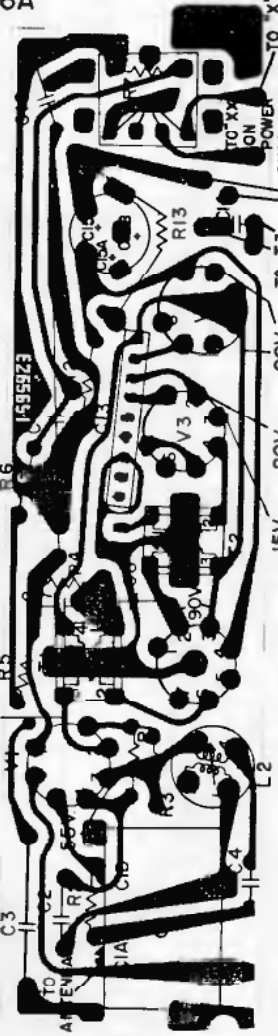

TO "A" BATTERY CONNECTION ON POWER SUPPLY BOARD.
TO "B" BATTERY CONNECTION ON POWER SUPPLY BOARD.
TO "A" BATTERY CONNECTION ON POWER SUPPLY BOARD.
TO "B" BATTERY CONNECTION ON POWER SUPPLY BOARD.

ALIGNMENT
SET VOLUME CONTROL AT MAXIMUM
SET OUTPUT METER OR SCOPE ACROSS
VOICE COIL OF SPEAKER
INDUCTIVELY COUPLE SIGNAL GENERATOR TO
RECEIVER
STEP 1 - SET BIG GEN AT 455 KC. WITH
RECEIVER TUNING GANG OPEN
STEP 2 - SET SIG GEN AT 1620 KC. WITH
RECEIVER TUNING GANG OPEN
STEP 3 - SET SIG GEN AT 1500 KC.
STEP 4 - SET SIG GEN AT 1500 KC.



REFERENCE CHART

| Tube | Pin 1 | Pin 2 | Pin 3 | Pin 4 | Pin 5 | Pin 6 | Pin 7 |
|------|-------|-------|-------|-------|-------|-------|-------|
| 1R5 | ELL | 2300 | 15K | 100K | ELL | 4.5M | ELL |
| 1U4 | ELL | 2300 | 2.5K | ELL | ELL | 2M | ELL |
| 1U5 | ELL | 1.8M | 5M | 1.5M | ELL | 2M | ELL |
| 3V4 | ELL | 2.1K | 75K | 100K | ELL | 3.5M | ELL |

UNLESS OTHERWISE NOTED
RESISTORS ARE 1/2 WATT
CAPACITORS ARE 50V UNLESS OTHERWISE NOTED
M.F. CAPACITORS ARE 50V UNLESS OTHERWISE NOTED
M.F. CAPACITORS ARE 50V UNLESS OTHERWISE NOTED

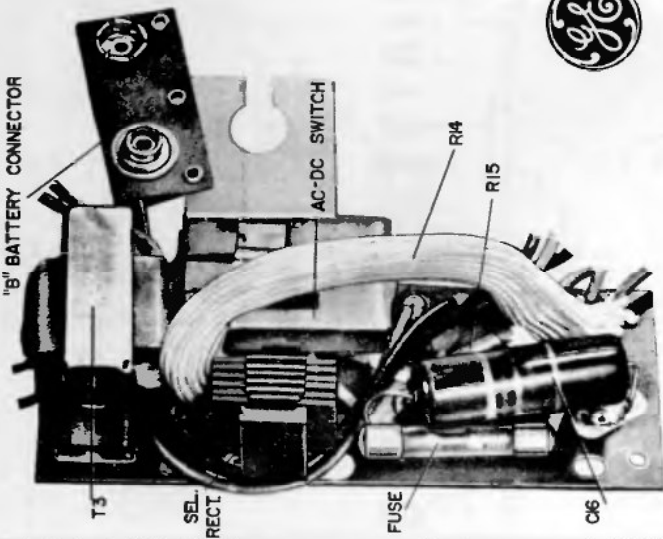

POWER CHASSIS TOP VIEW

GENERAL ELECTRIC

Models P755A, P805, and P806

TRANSISTOR CHART

| TR1* | TR2 | TR3 | TR4 | TR5 |
|--------|-------|--------|-------|--------|
| 2N194A | 2N135 | 2N169 | 2N192 | 2N241A |
| 2N212 | | 2N233A | 2N324 | 2N270 |
| (1297) | | 2N293 | 2N406 | 2N321 |
| | | 2N314 | | 2N408 |

*When TR1 is 2N169, resistor R1 is 82K.
When 2N212(1297) is used, R1 is 33K.

TO REMOVE CIRCUIT BOARD

1. Remove screw from the cabinet back.
2. Insert a coin in either slot on the cabinet bottom and twist to remove the cabinet back.
3. Remove screw holding tuning dial.
4. Remove 3 screws under tuning dial to release tuning gang from cabinet front.
5. Remove 3 hexhead screws and one 11/32" nut (bottom center of circuit board) holding circuit board to bosses on cabinet front.
6. Fold tuning gang and circuit board out of cabinet front toward the volume control end. It is not necessary to remove volume control to repair the circuit board.

TO REMOVE VOLUME CONTROL

1. Remove cabinet back.
2. Remove hex head screw from center of volume control knob.
3. Remove chassis.
4. Remove pal nut holding volume control to cabinet front boss.

TO REMOVE SPEAKER

1. Remove cabinet back.
2. Remove chassis.
3. Unsolder speaker wires.
4. Remove clips holding speaker to cabinet front.

TROUBLE SHOOTING

A check of battery current drain will indicate if a receiver is operating properly. To measure the current drain, remove cabinet back, unsnap ground section of battery terminal and swing away from battery. Connect milliammeter between battery terminal and battery contact.

The total current drain should be between 19.0 and 24.0 ma. The current drain is measured with no-signal-conditions (tuning gang closed) and volume control at maximum.

If an excessive current drain is recorded, the individual collector current readings should be checked on each transistor. Current drain is an important indication of the transistor operating conditions.

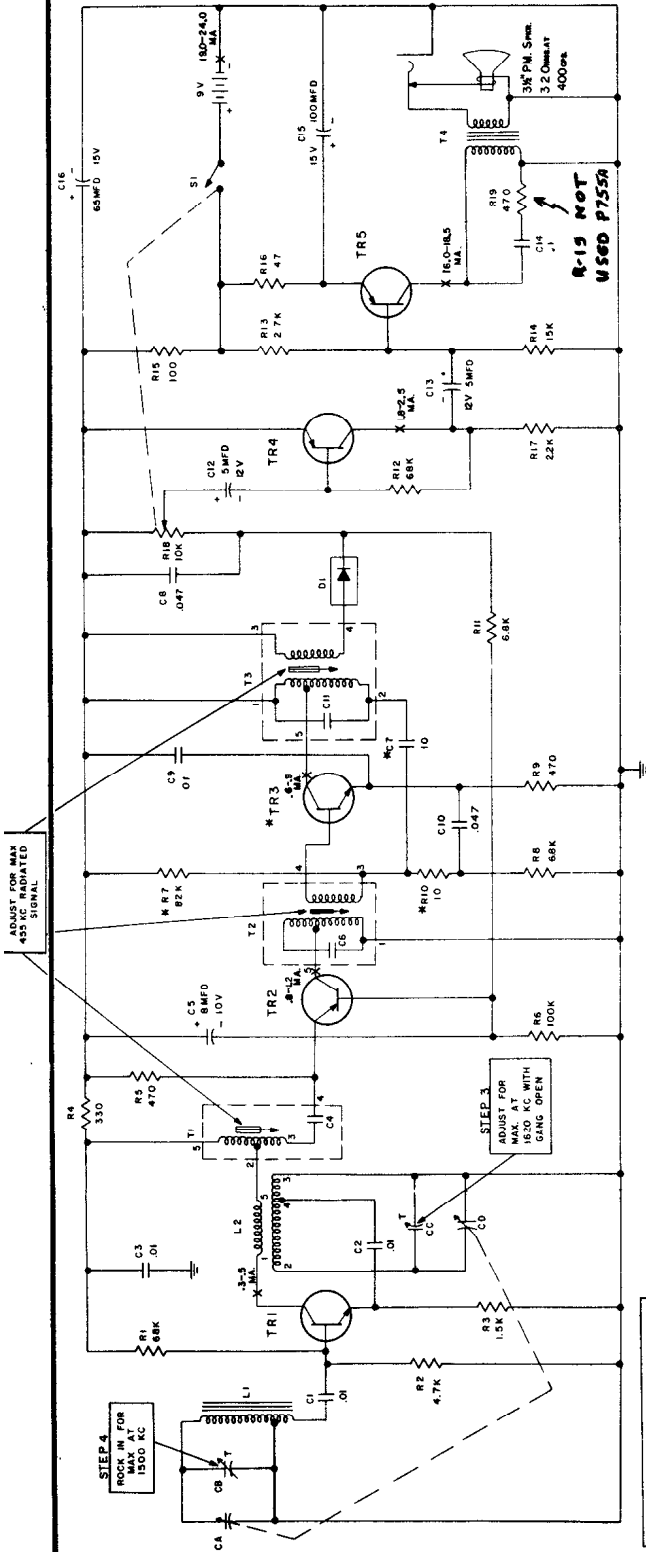

ALIGNMENT
SET VOLUME CONTROL AT MAXIMUM.
CONNECT OUTPUT METER OR SCOPE
TO POINT MARKED "X" ON TUNING GANG.
TO RECEIVER.
STEP 1. SET SIG. GEN. AT 455 KC.
WITH RECEIVER TUNING GANG OPEN.
STEP 2. SET SIG. GEN. AT 1620 KC.
WITH RECEIVER TUNING GANG OPEN.
STEP 3. SET SIG. GEN. AT 1500 KC.
TUNE RECEIVER TO 1500 KC.

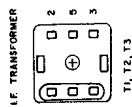
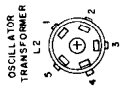

T1, T2, T3
BOTTOM VIEWS

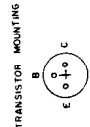

UNLESS OTHERWISE NOTED...
CAPACITORS MORE THAN 1.0 MF
SHOULD BE ELECTROLYTIC.
RESISTORS ARE 1/2 WATT, K = 1000.
MEASURE COLLECTOR CURRENTS WITH A
MILLIAMMETER. ALWAYS MEASURE WITH
THE CIRCUIT MARKED "X" AND ALSO
BATTERY CURRENT AT POINT MARKED "X"
IN BATTERY CIRCUIT.
*WHEN TR3 IS 2N169
C7, C10, C11, C12, C13, C14, C15
R10 IS REPLACED BY A JUMPER.

GENERAL ELECTRIC COMPANY

Models P671A,B, P672A,B, P673A,B, P674B

SPECIFICATIONS

| | |
|-------------------------------|---|
| CABINETS: (Plastic) | Models P671A,B - Black and White Models P672A,B - White and Terra Cotta Models P673A,B - Turquoise and White Model P674B - Green |
| ELECTRICAL RATING: | 105-120 Volts A-C (50 to 60 cycles) or DC 1 "A" battery - 7 1/2 volt Eveready No. 717 or equivalent 1 "B" Battery - 90 Volt Eveready No. 479 or equivalent |
| OPERATING FREQUENCIES: | Tuning range 540-1600 KC I-F 455 KC |

CHASSIS REMOVAL:

The chassis is easily removed by means of the following procedure:

1. Swing down cabinet front by grasping front at top edge under handle.
2. Remove tuning and volume control knobs by pulling straight off their shafts.
3. Remove the two small Phillips-head screws from the top rear edge of the metal chassis mounting bracket.
4. Slide chassis and bracket out of cabinet.
5. Remove bracket from chassis by unscrewing the 1/4" mounting screw from the bracket.

The power supply chassis is removed from the cabinet by removing the four small hex-head mounting screws.

The speaker is mounted on the cabinet front and may be removed by taking off the four speaker mounting clips which secure the speaker to the four bosses on the inside of the cabinet front.

IMPORTANT: Use care when replacing defective parts. Apply as little heat to terminals and connections as possible to remove parts, as excessive heat will damage the plated wiring on the chassis boards.

When replacing knobs, do not force them on, as too much pressure may cause circuit board to bend and crack.

VOLUME CONTROL REPLACEMENT:

The chassis must first be removed from the cabinet as described under CHASSIS REMOVAL, then replace volume control as follows:

1. Cut off the three control lugs and the four on-off lugs.
2. Heat the remaining part of the lugs on the circuit board and pull out with long-nose pliers.
3. Clean all mounting holes of all excess solder.
4. The volume control on-off switch (catalog no. RRC-367) is used as the replacement. This control has a combined mounting bracket which can be mounted with the control on the circuit board. There are four holes on the board in which the mounting bracket can be inserted and soldered on the dip-soldered side of the circuit board.

TO REPLACE A TUBE SOCKET:

Cut the socket free by cutting all of the socket terminals at the chassis. One socket (V2) has a center terminal which must be unsoldered. Now, heat the pieces of terminals remaining in the board only enough so they may be pushed out. The new socket can now be inserted into the holes left by the old one and soldered into place.

BATTERY INSTALLATION:

Insert batteries in place as shown in the Tube and Battery location illustration. Make sure the battery connections are well seated.

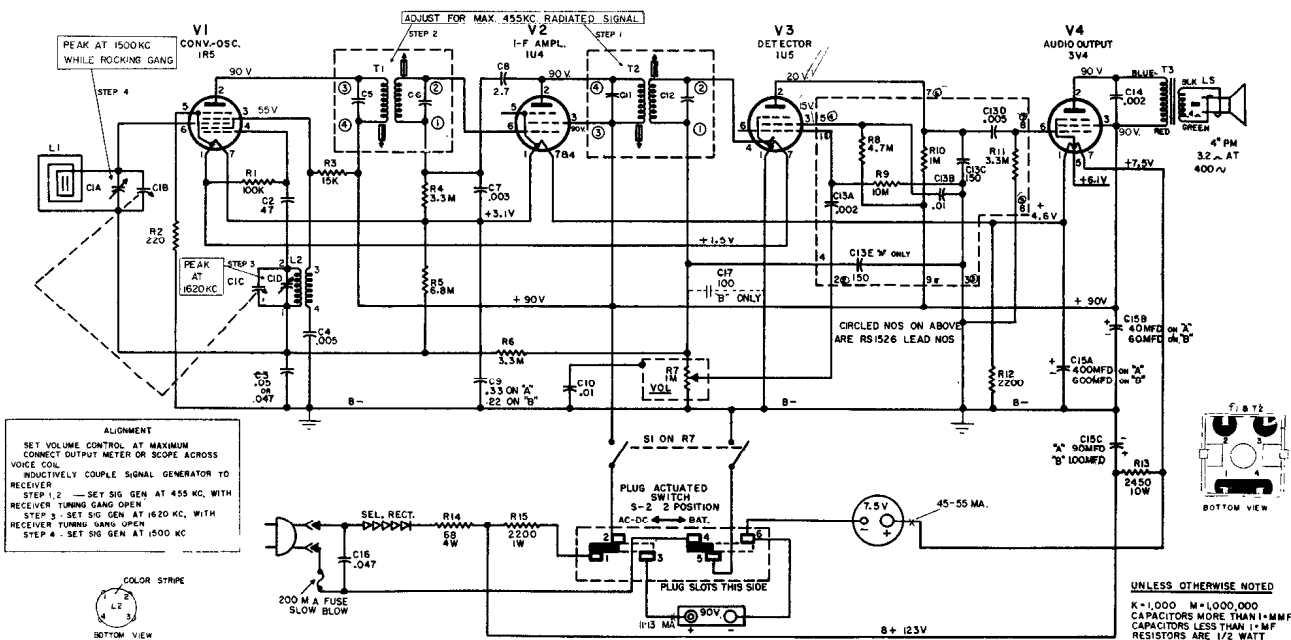

GENERAL ELECTRIC COMPANY

Model RP1110A

SPECIFICATIONS

| | |
|---------------------|--|
| ELECTRICAL RATING: | 105-120 Volts 60 Cycle AC 45 Watts |
| POWER OUTPUT: | Undistorted: 1.5 Watts Maximum: 2 Watts |
| RECORD CHANGER: | Model CH10 four speed automatic with 90 Volt AC motor |
| PHONOGRAPH PICK-UP: | Dual Sapphire Stylus Astatic 81T or equivalent |

TROUBLESHOOTING

The tube filaments and changer motor are connected in series. An open filament in an amplifier tube will prevent the operation of the changer motor. Be sure the tubes are operating properly before troubleshooting changer.

The input AC voltage rating of the changer is 90 volts. When testing a changer disconnected from amplifier, a 100 ohm 10 watt resistor may be used as a substitute in place of tube filaments, or a variac set at 90 volts must be inserted between changer and power line. Do not plug changer into a 105-120 volt outlet.

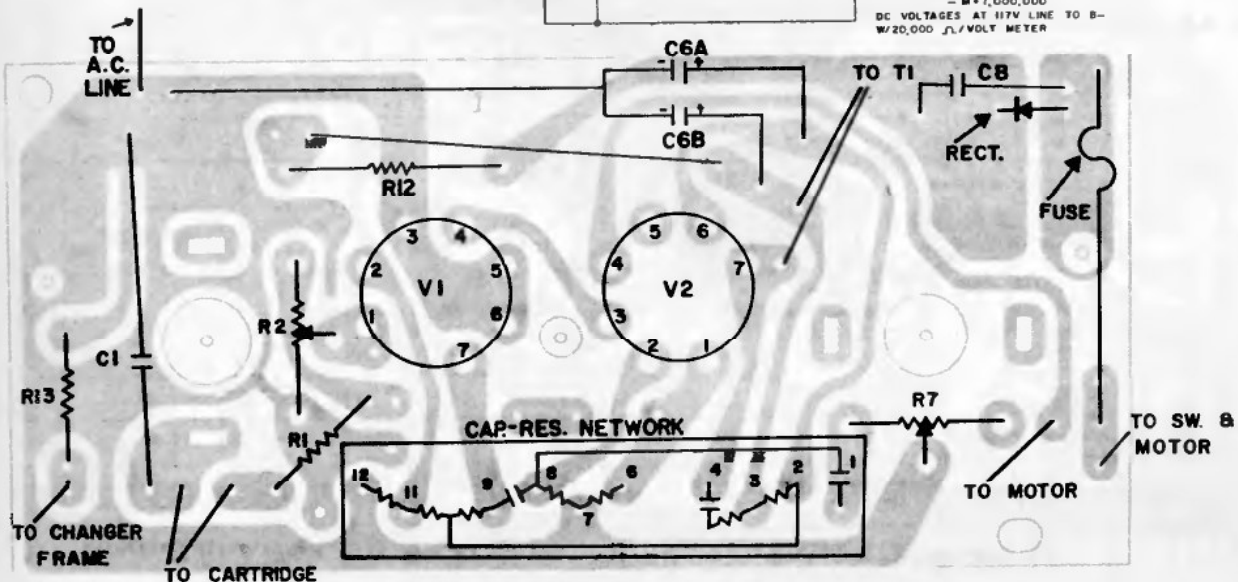
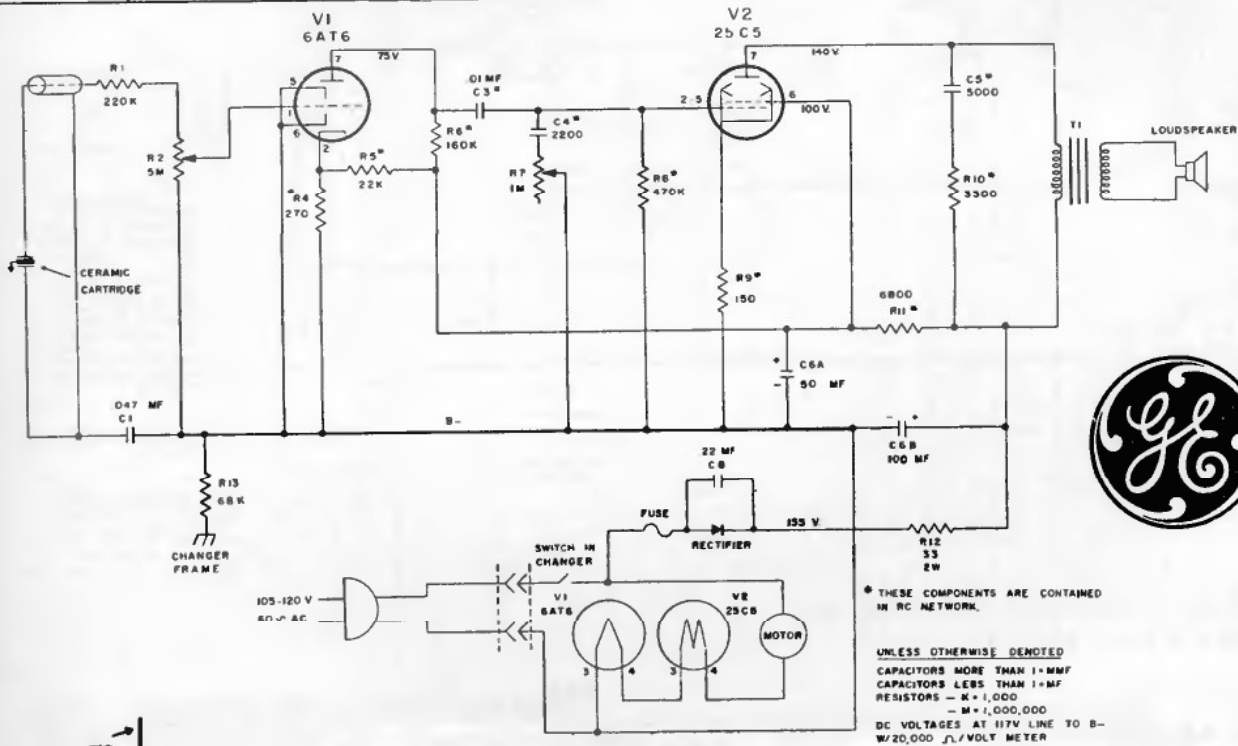

COMPONENT LOCATIONS - BOTTOM VIEW - RP-1110A

GENERAL ELECTRIC COMPANY Models RP1120A, RP1120B

TO REPLACE TUBES

1. Open cabinet lid.
2. Remove screws holding vent panel board and interlock.
3. Remove vent panel board (interlock is automatically disconnected.)

TO REMOVE AMPLIFIER CHASSIS

1. Follow steps 1 through 3 as above.
2. Remove loudness and tone knobs.
3. Loosen screws on interlock bracket; slide interlock out of mounting slot. (Mark location of bracket on cabinet before removing so that bracket can be "keyed" to correct location when replacing.)

4. Remove the three hexhead nuts from screws on cabinet brace above speakers and the three hexhead nuts from screws on cabinet brace under speakers.
5. Lift out grille (with all electronic components) and place down in front of cabinet carefully.
6. Unscrew two clamps holding wires from chassis to changer.
7. Remove amplifier chassis by unscrewing the three screws holding chassis to grille.
Before replacing knobs, turn control shafts fully counterclockwise; press on knobs with the knob indicator dot to the left of center at the bottom.

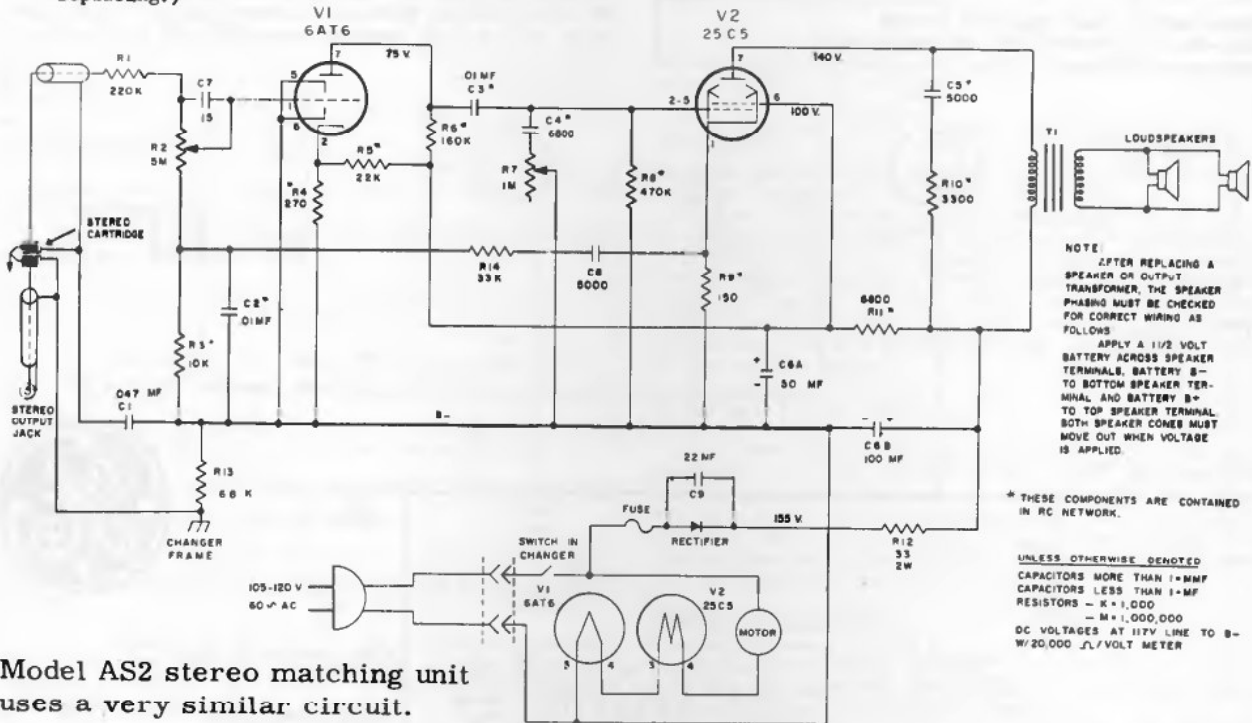

Model AS2 stereo matching unit uses a very similar circuit.

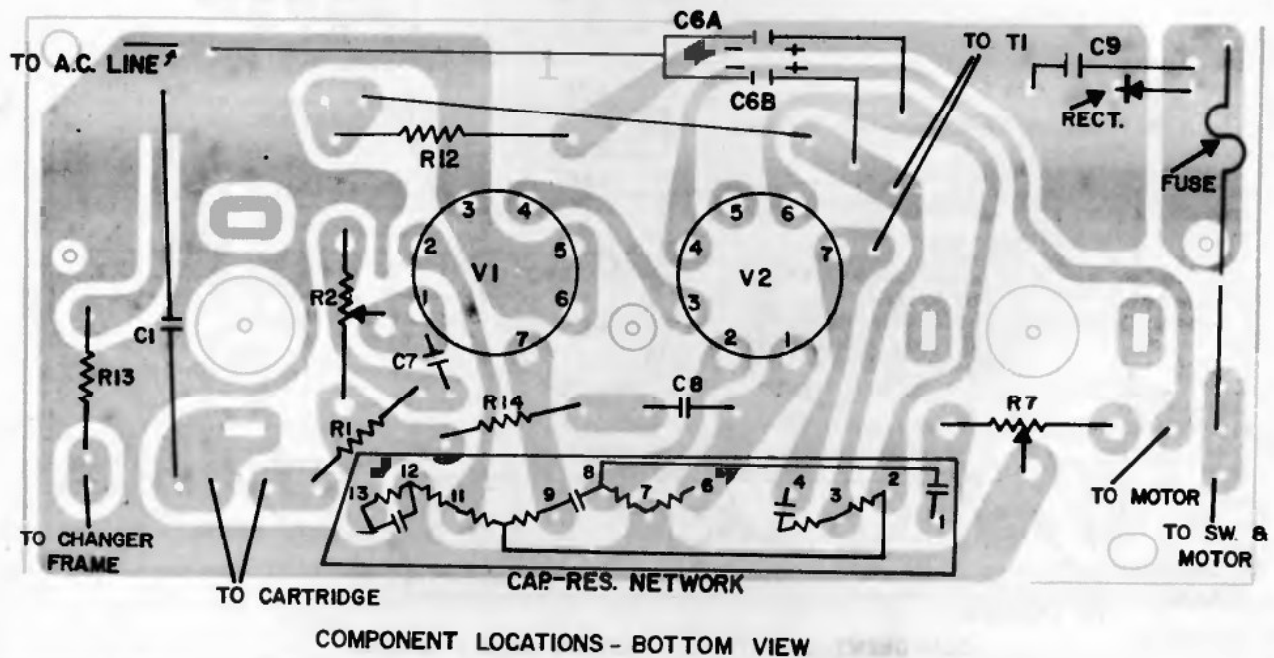

GENERAL ELECTRIC

RADIO/PHONO
MODEL
RPI160A

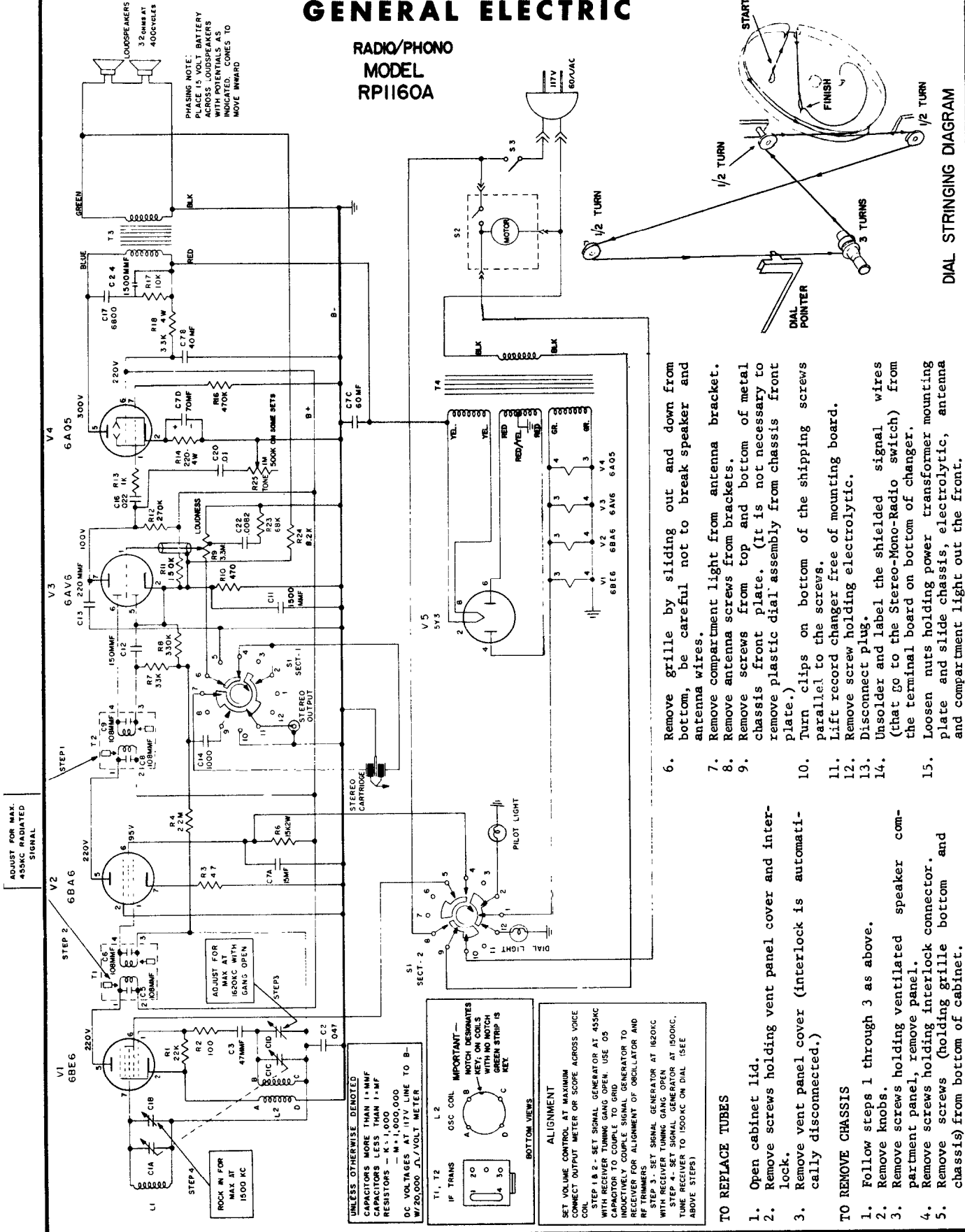

6. Remove grille by sliding out and down from bottom, be careful not to break speaker and antenna wires.
7. Remove compartment light from antenna bracket.
8. Remove antenna screws from brackets.
9. Remove screws from top and bottom of metal chassis front plate. (It is not necessary to remove plastic dial assembly from chassis front plate.)
10. Turn clips on bottom of the shipping screws parallel to the screws.
11. Lift record changer free of mounting board.
12. Remove screw holding electrolytic.
13. Disconnect plug.
14. Unsolder and label the shielded signal wires (that go to the Stereo-Mono-Radio switch) from the terminal board on bottom of changer.
15. Loosen nuts holding power transformer mounting plate and slide chassis, electrolytic, antenna and compartment light out the front.

GENERAL ELECTRIC COMPANY

MODELS
RT1230A
RT1231A

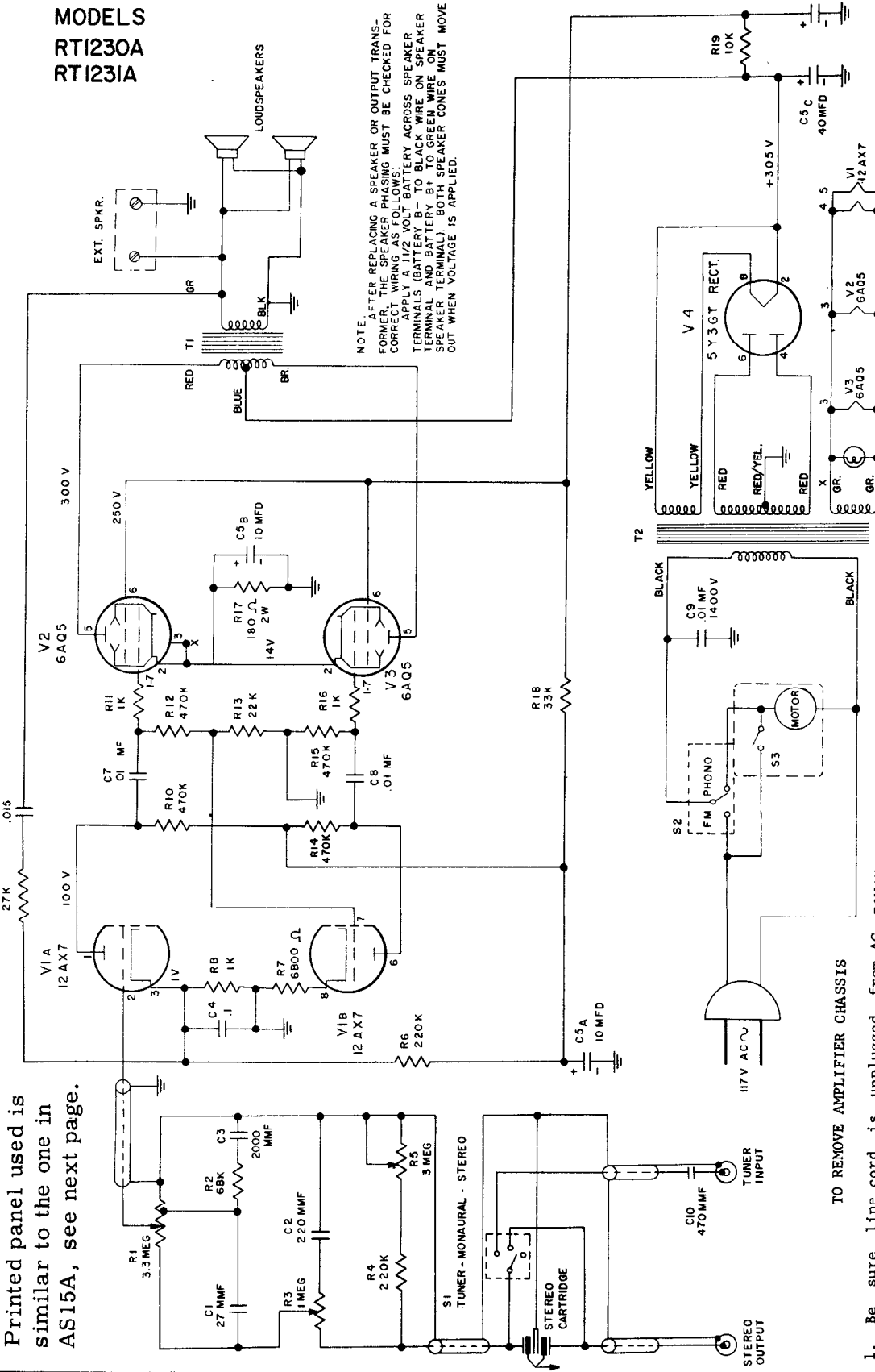

Printed panel used is similar to the one in AS15A, see next page.

NOTE: AFTER REPLACING A SPEAKER OR OUTPUT TRANSFORMER, THE SPEAKER PHASING MUST BE CHECKED FOR CORRECT WIRING AS FOLLOWS: APPLY A 1 1/2 VOLT BATTERY ACROSS SPEAKER TERMINALS (BATTERY B+ TO BLACK WIRE ON SPEAKER TERMINAL, BATTERY B- TO GREEN WIRE ON SPEAKER TERMINAL). BOTH SPEAKER CONES MUST MOVE OUT WHEN VOLTAGE IS APPLIED.

UNLESS OTHERWISE DENOTED
CAPACITORS MORE THAN 1: mmf
CAPACITORS LESS THAN 1: mf
RESISTORS - K = 1,000
- M = 1,000,000
DC VOLTAGES AT 117V LINE TO B-
W/20,000 Ω/VOLT METER

TO REMOVE AMPLIFIER CHASSIS

1. Be sure line cord is unplugged from AC power source.
2. Remove cabinet bottom.
3. Remove the 5Y3 tube from tube socket.
4. Remove the two hex head screws holding chassis to cabinet brace.
5. Remove clamps holding power cord and wires.
6. Carefully lift chassis up, tilt and slide out.
7. Remove circuit board by removing screws holding circuit board to chassis.

TO REMOVE SPEAKERS

1. Be sure line cord is unplugged from AC power source.
2. Remove cabinet bottom.
3. Remove two screws under speakers that hold grille to cabinet.
4. Pull grille with speakers attached straight out through cabinet bottom. Keep grille flush with cabinet front when pulling out.

GENERAL ELECTRIC

Models AS15A and AS16A

SPECIFICATIONS

| | |
|--------------------|--|
| CABINET: | AS15A - Mahogany AS16A - Blond Oak |
| ELECTRICAL RATING: | 105-120 volts 60 cycles AC 75 watts |
| POWER OUTPUT: | Maximum 10 watts 10% Distortion 8 watts |

TO REMOVE CHASSIS FROM CABINET

1. Remove cabinet back.
2. Remove two screws holding chassis to cabinet.
3. Unscrew clamps holding connecting wires and remove screws holding electrolytic condenser and output transformer.
4. Pull pilot light holder off bracket.
5. Remove Chassis.

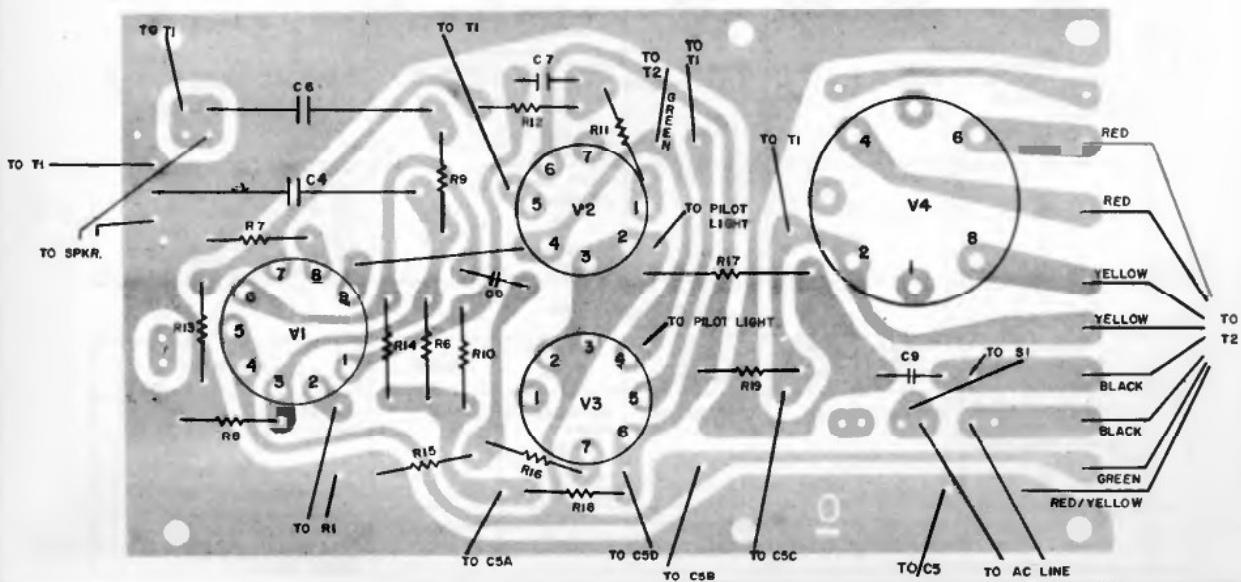
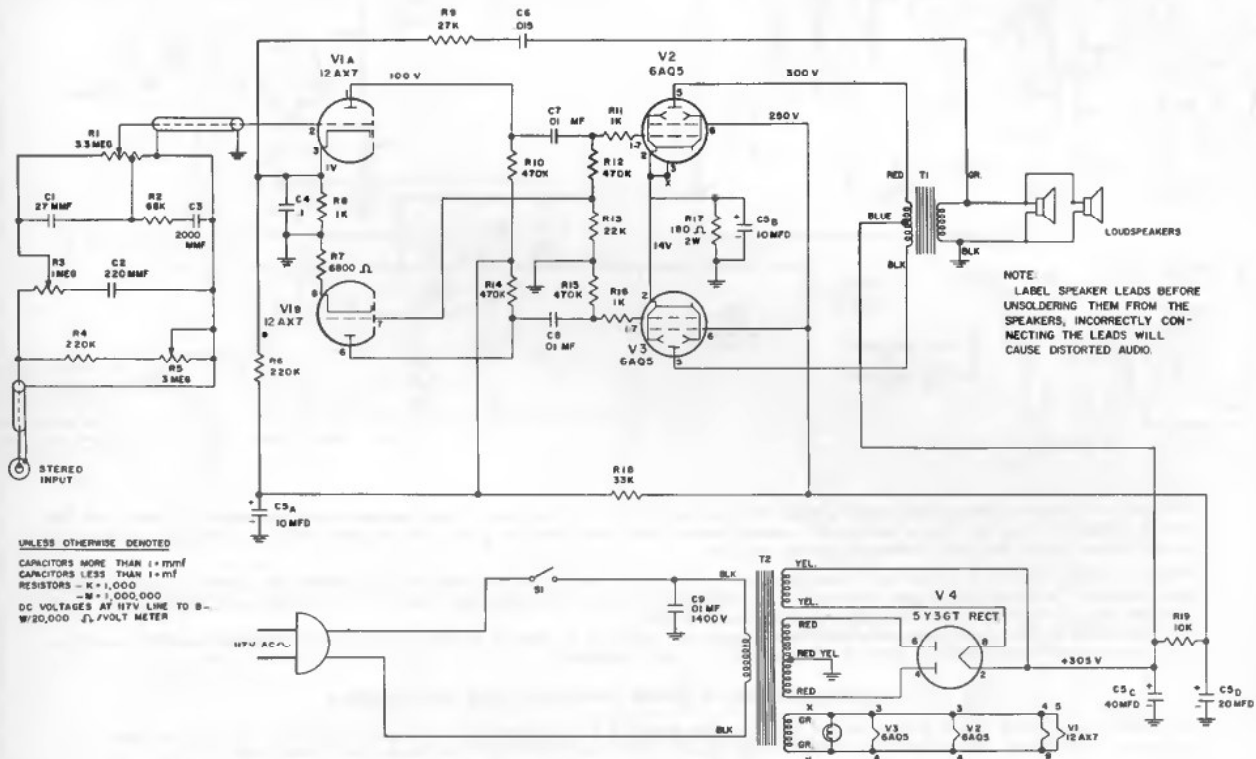

VOLUME R-19, MOST-OFTEN-NEEDED 1959 RADIO SERVICING INFORMATION

GRANCO PRODUCTS INC. MODEL 601 FM RADIO

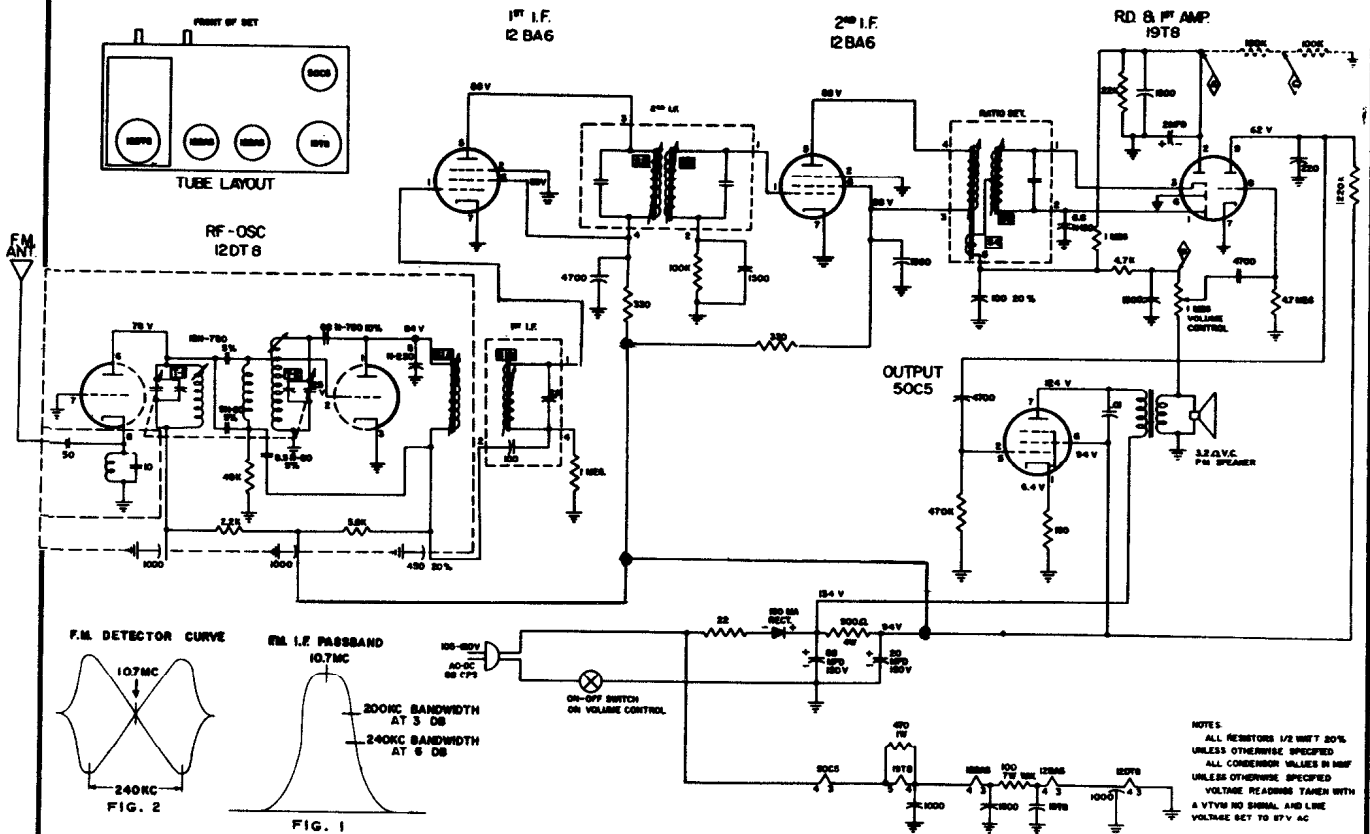

NOTE #1 - To remove chassis from cabinet, place receiver face down on flat surface. Remove bottom screw and proceed to remove rear portion of cabinet by slipping sides of cabinet with palm of hands and at same time lifting set. The chassis, which is mounted on the front portion of cabinet, should fall out. Proceed to service chassis.

NOTE #2 - This chassis is connected to one side of the power line. On AC operation an isolation transformer should be used to prevent shock hazard. To protect the signal generator, if no isolation transformer is available or if the radio is operated on DC, connect a 0.1 MFD capacitor between the high side of the signal generator and the radio.

The output of the signal generator should be no higher than necessary to obtain a usable output reading. Use a non-metallic type alignment screw-driver for adjustments. Connect signal generator ground to chassis.

FM IF ALIGNMENT USING FM SIGNAL GENERATOR AND OSCILLOSCOPE

FREQUENCY MODULATE THE IF SIGNAL WITH A 60 CYCLE SINE WAVE TO A TOTAL DEVIATION OF 450 KC. ADJUST THE OSCILLOSCOPE INTERNAL HORIZONTAL DEFLECTION VOLTAGE TO 120 CYCLES, AND SYNCHRONIZE IT WITH THE 60 CYCLE SINE WAVE.

| | SIGNAL GENERATOR COUPLING | SIGNAL GEN. FREQ. | BAND SWITCH POS. | RADIO DIAL SETTING | CONNECT SCOPE | ADJUST | REMARKS |
|----|---|---------------------------|------------------|---------------------------|---|-----------------------|---|
| 6. | TO PIN 8 (CATHODE) OF 12DT6 THROUGH A 50 MMF (REMOTE ANT. HANK) | 10.7MC (450KC TOTAL DEV.) | FM | POINT OF NON-INTERFERENCE | VERT. AMP TO POINT ◇ LOW SIDE TO CHASSIS. | S4, S3, S2, S1B, S1A. | DISCONNECT STABILIZER CAPACITOR 2MFD. ADJUST FOR CURVE OF MAXIMUM AMPLITUDE AND SYMMETRY SIMILAR TO FIG. 1. |
| 7. | " | " | " | " | VERT. AMP TO POINT ◇ LOW SIDE TO CHASSIS. | S5 | RECONNECT STABILIZING CAPACITOR 2MFD. ADJUST SO THAT 10.7MC OCCURS AT CENTER OF CROSSOVER LINES, SIMILAR TO FIG. 2. SLIGHTLY RETOUCH S-4 FOR MAXIMUM AMPLITUDE AND STRAIGHTNESS OF CROSSOVER LINE, PROCEED WITH STEP 8. |

FM RF ALIGNMENT

| | SIGNAL GENERATOR COUPLING | SIGNAL GEN. FREQ. | BAND SWITCH POS. | RADIO DIAL SETTING | CONNECT VTVM | ADJUST | REMARKS |
|----|---|-------------------|------------------|--------------------|--|--------------|---|
| 8. | TO PIN 8 (CATHODE) OF 12DT6 THROUGH A 50 MMF (REMOTE ANT. HANK) | 108MC | FM | 108MC (SLUGS OUT) | DC PROBE TO POINT ◇ COMMON TO CHASSIS. | T1, T2 | ADJUST FOR MAXIMUM DEFLECTION. |
| 9. | " | 88MC | " | 88MC (SLUGS IN) | " | PADDER FLAPS | MOVE PADDER FLAP'S CLOSER OR FURTHER FROM D.C. & RF COILS FOR MAX. DEFLECTION. REPEAT STEP 8 & 9 FOR HIGHEST READING. |

GRANCO PRODUCTS INC. MODEL 701 FM-AM RADIO

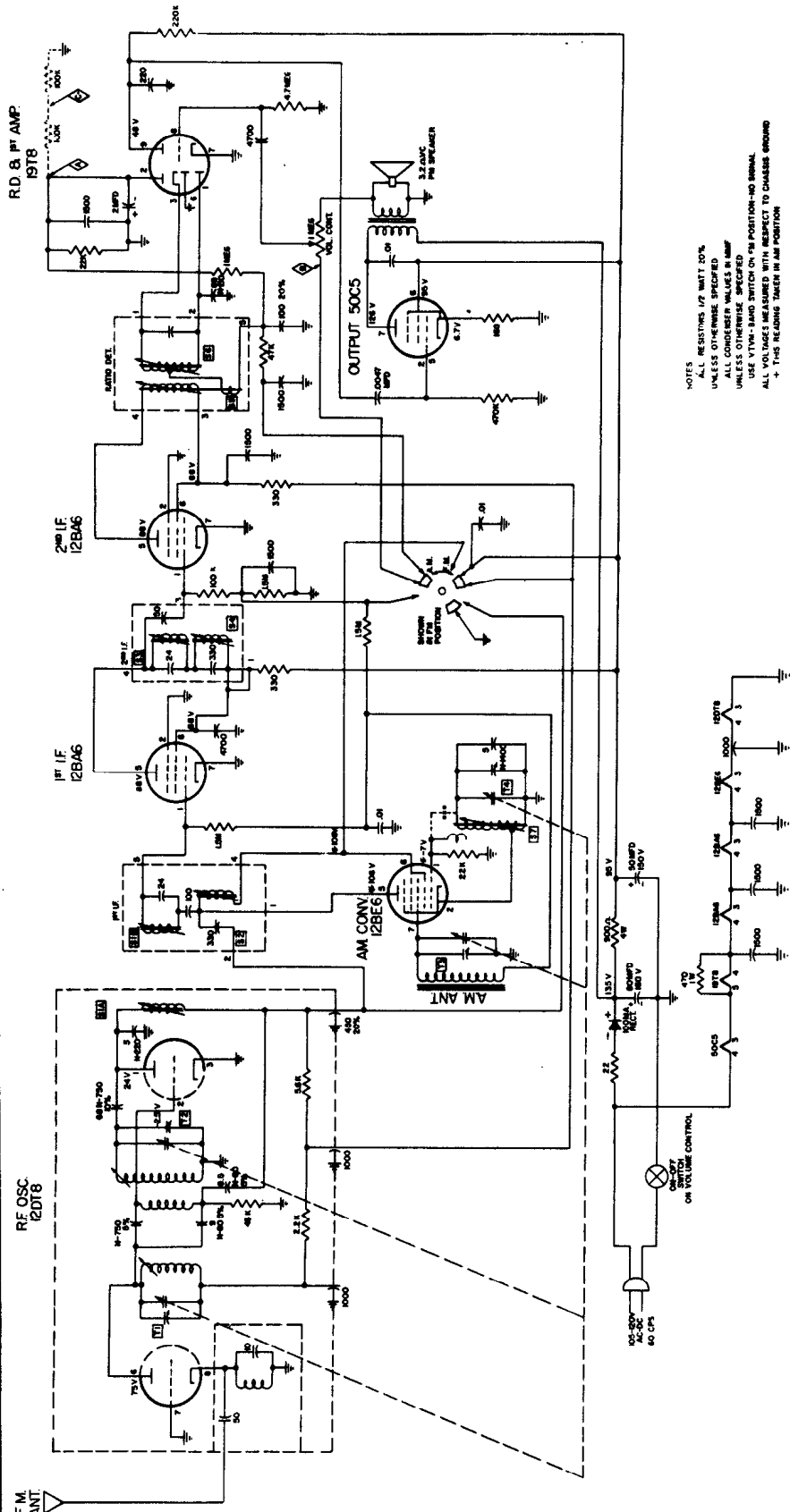

NOTES
 ALL RESISTORS 1/2 WATT 5%
 UNLESS OTHERWISE SPECIFIED
 UNLESS OTHERWISE SPECIFIED
 USE VTVM - BAND SWITCH ON "FM" POSITION - NO SIGNAL
 ALL VOLTAGES MEASURED WITH RESPECT TO CHASSIS GROUND
 → THIS READING TAKEN IN AM POSITION

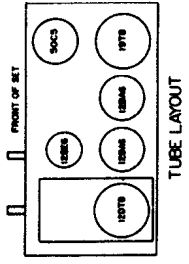

AM IF & RF ALIGNMENT

| SIGNAL GENERATOR COUPLING | SIGNAL GEN. FREQ. | BAND SWITCH POS. | RADIO DIAL SETTING | CONNECT VTVM | ADJUST | REMARKS |
|------------------------------|-------------------|------------------|-------------------------|-------------------|--------|---|
| 1. TO PIN 7 (GRID) OF 12BE6. | 485KC (400 MOD.) | AM | TUNING GANG FULLY OPEN. | ACROSS VOICE COIL | S4, S2 | ADJUST FOR MAXIMUM DEFLECTION. |
| 2. LOOP (RADIATED) | 610KC | " | TUNE TO 610KC SIGNAL | " | S7 | ADJUST FOR MAXIMUM DEFLECTION. WHILE ROCKING TUNING GANG. |
| 3. | 1650KC | " | TUNING GANG FULLY OPEN. | " | T3, T4 | ADJUST FOR MAXIMUM DEFLECTION. REPEAT STEPS 1, 2, & 3. |

For FM alignment information see instruction under Model 601, on preceding page, which can be applied to this set as well.

MONTGOMERY WARD & CO.

Model 1120A, -B

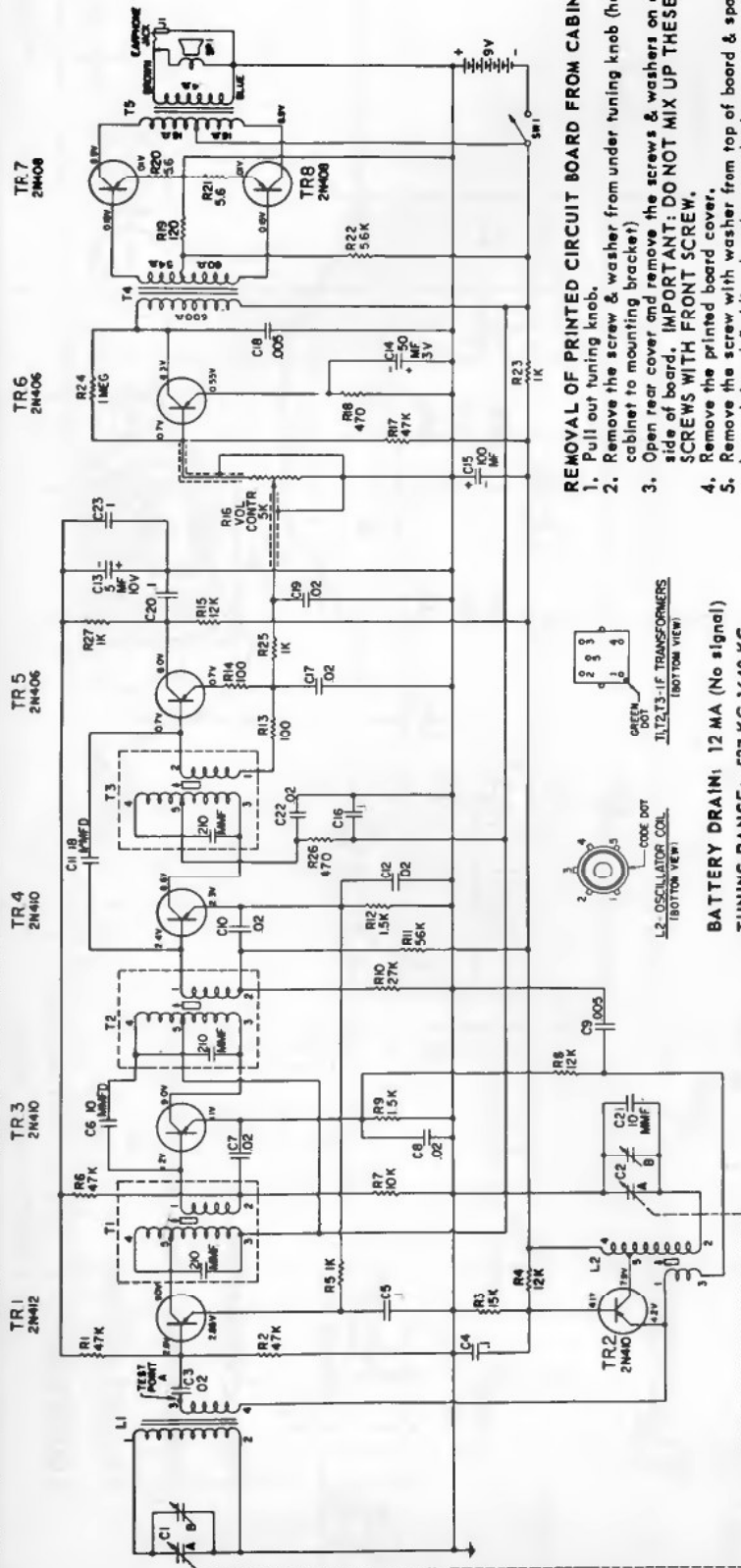

REMOVAL OF PRINTED CIRCUIT BOARD FROM CABINET

1. Pull out tuning knob.
2. Remove the screw & washer from under tuning knob (holding cabinet to mounting bracket)
3. Open rear cover and remove the screws & washers on each side of board. **IMPORTANT: DO NOT MIX UP THESE SCREWS WITH FRONT SCREW.**
4. Remove the printed board cover.
5. Remove the screw with washer from top of board & spacer beneath board (holding board to speaker).
6. Lift the printed board out of cabinet.
7. Unsolder speaker leads, if servicing requires removal of board from cabinet.

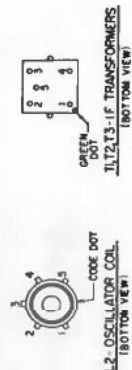

BATTERY DRAIN: 12 MA (No signal)
 TUNING RANGE: 537 KC-1640 KC
 I. F. STAGES: 455 KC

NOTES
 1. VOLTAGES SHOWN AT EACH TRANSISTOR ELECTRODE ARE WITH NO SIGNAL AND VOLUME CONTROL SET AT MAXIMUM.
 2. UNLESS OTHERWISE INDICATED, ALL RESISTANCE VALUES ARE IN OHMS-1/2 W.
 3. ALL RESISTANCE VALUES ARE IN OHMS-1/2 W.

TOP VIEW OF BOARD SHOWING ALIGNMENT ADJUSTMENT LOCATIONS.

- 1) 1st I.F.
- 2) OSC. COIL
- 3) TRIM. C1B
- 4) TRIM. C2B
- 5) 2nd I.F.
- 6) 3rd I.F.



MONTGOMERY WARD & CO.
Model GEN-1628A

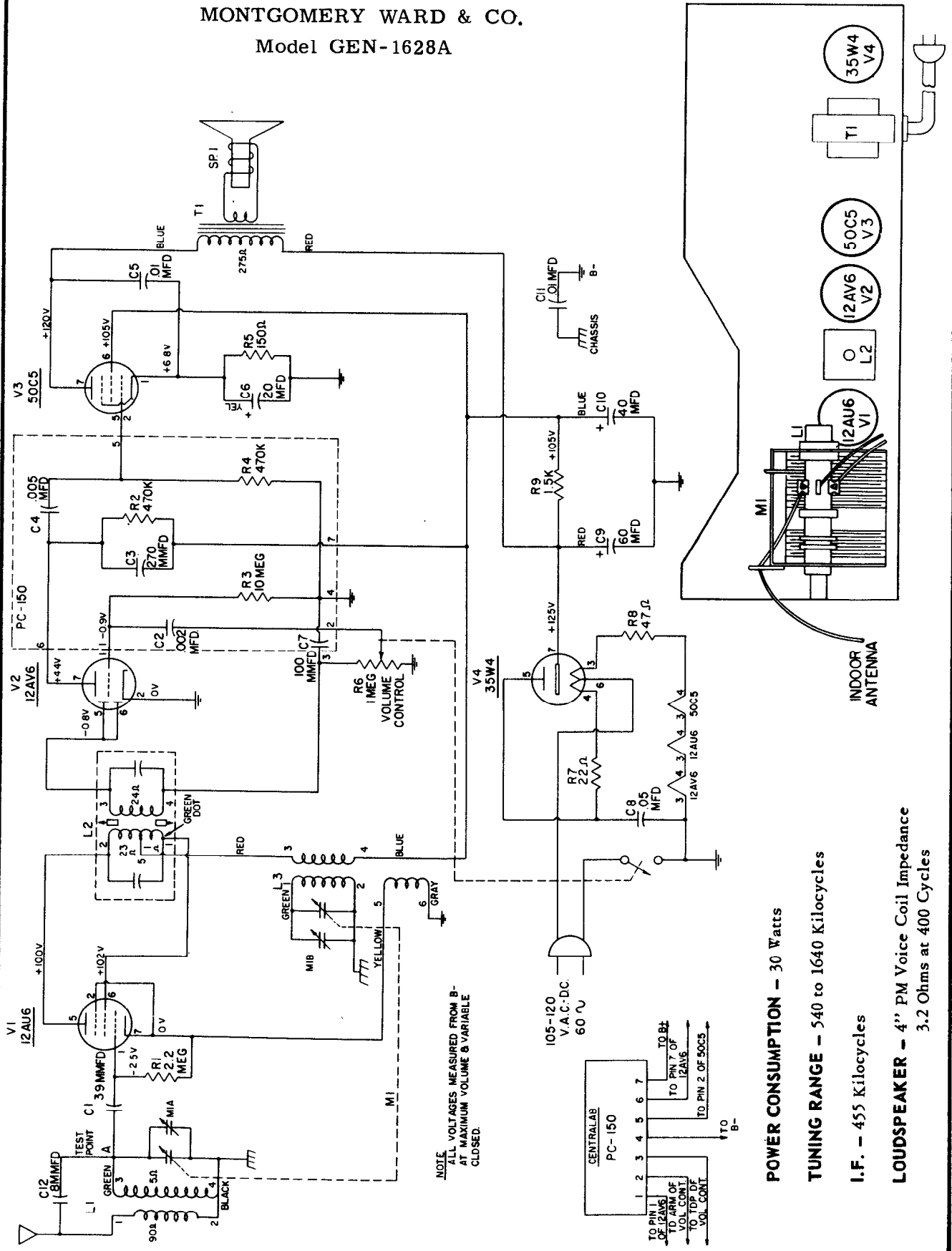

MOTOROLA

AUTO RADIO

MODEL
9AX

2N176
PWR AMP
MN63 OR 2N652
DRIVER

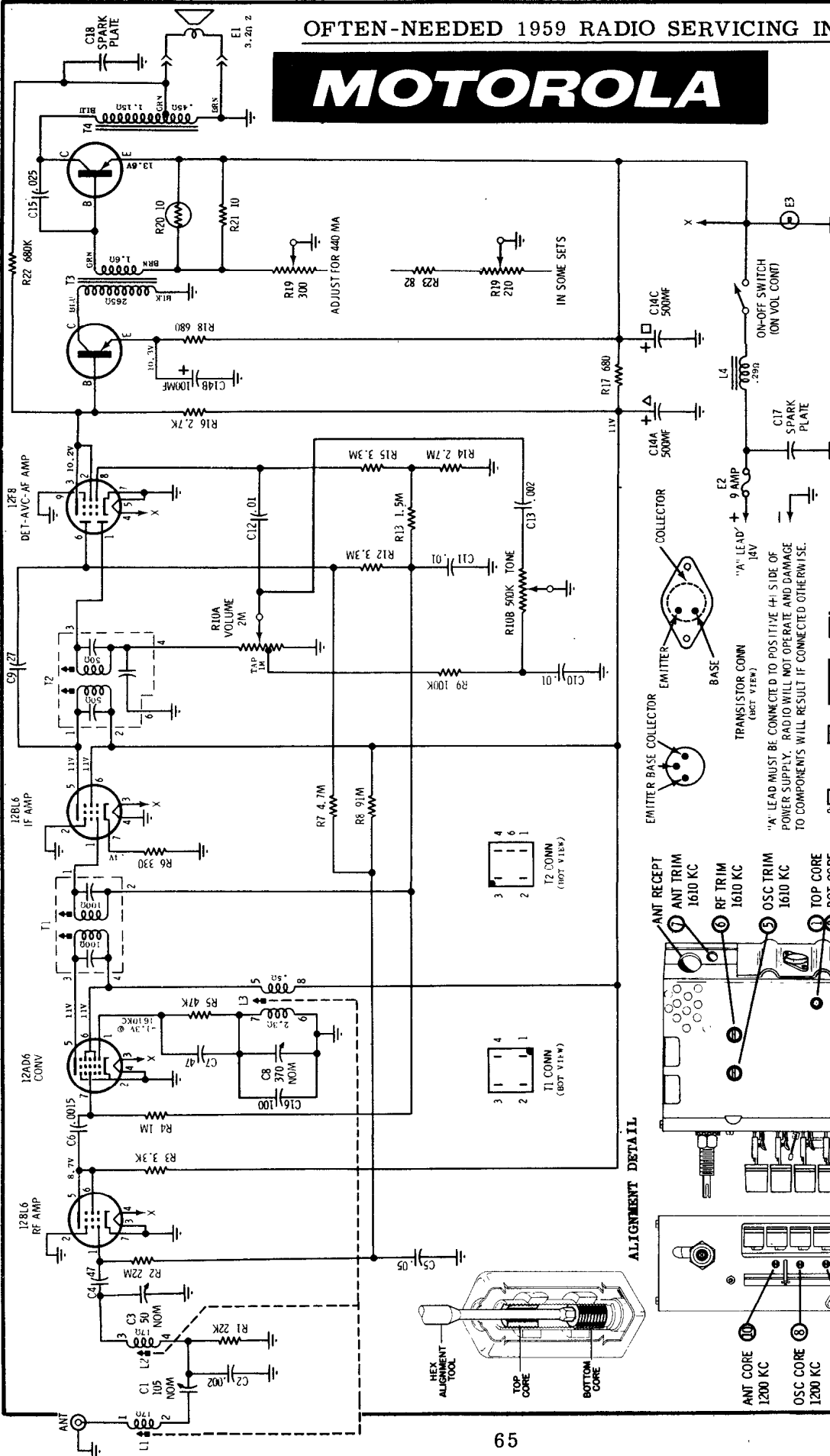

NOTES:
CAPACITORS - Decimal values in MF, all others in MMF unless otherwise specified.
VOLTAGES - Measured from point indicated to chassis with a VTVM. No signal input. Tolerance $\pm 10\%$.
INPUT VOLTAGE - 14V DC
TUNING RANGE - 540 KC TO 1610 KC.
IF FREQ. - 262.5 KC.

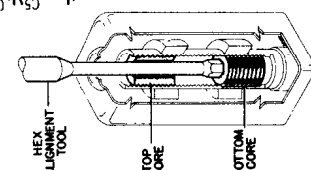
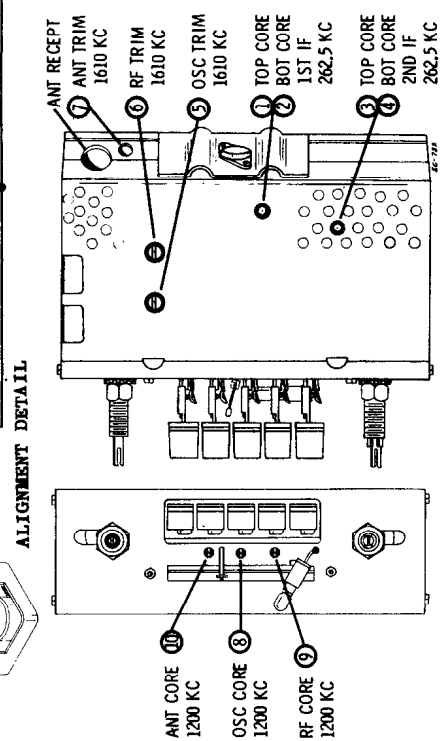
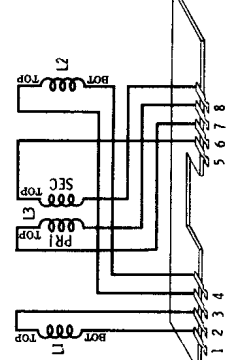
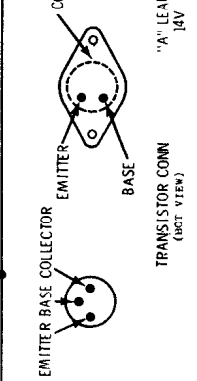

MOTOROLA

Model CTA9X
 Models BKA9X, OEA9X, PCA9X,
 are electrically very similar to
 CTA9X covered on this page.

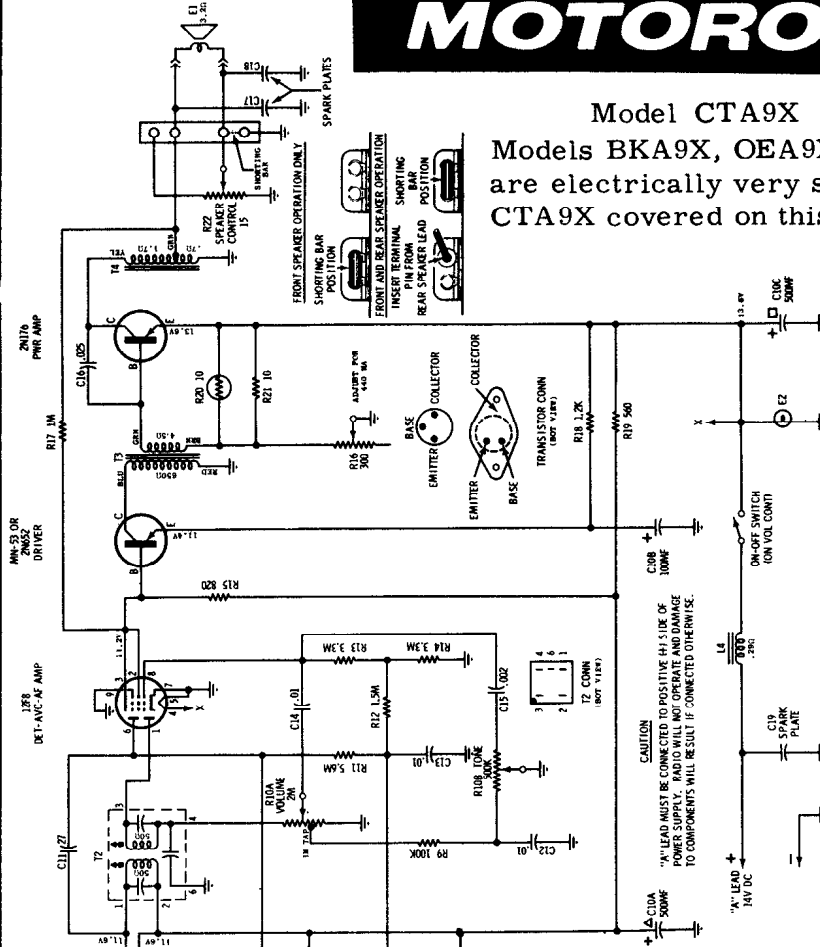

POWER TRANSISTOR CURRENT ADJUSTMENT - After a power transistor has been replaced, the collector current should be checked and adjusted for proper operation.

- Connect a 0-3 amp DC ammeter in series with the "A" lead.
- Remove output transistor from its socket.
- Turn radio on and read ammeter with 12.6 volts input to "A" lead (approximately 800 ma). **NOTE READING.**
- Turn radio off and replace transistor
- Turn radio on and adjust R-16 for a 360 ma increase over reading noted in step c with 12.6 volts input to "A" lead.

NOTE: Two values of radio input voltage are given as a convenience to service personnel in order to accommodate different power sources. The current value of 440 ma stated on the schematic is for 14 volts DC input to receiver "A" lead.

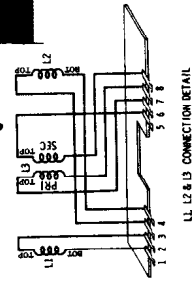
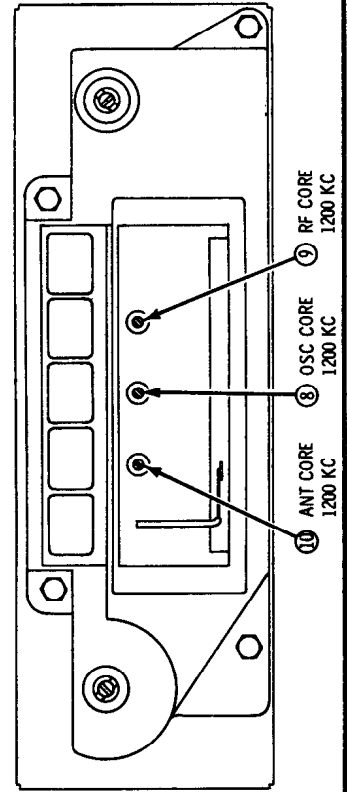
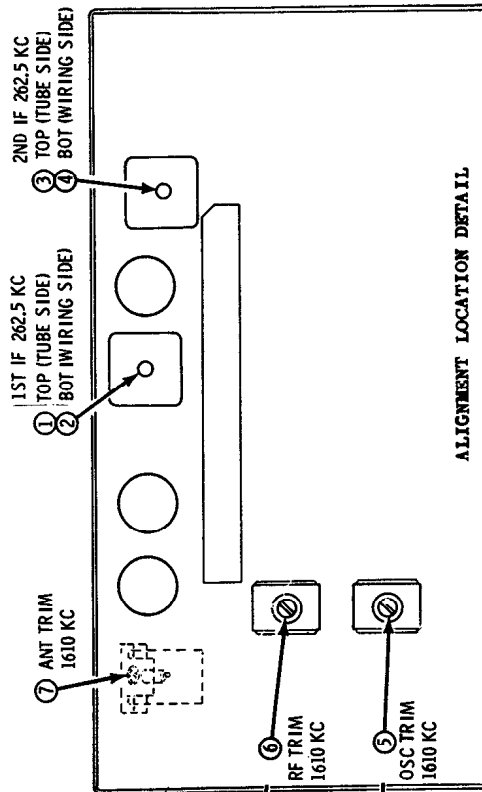

NOTES:
 CAPACITORS - Decimal values in MF, all others in MUF unless otherwise specified.
 VOLTAGES - Measured from point indicated to chassis with a VTVM. No signal input. Tolerance ±10%.
 INPUT VOLTAGE - 14V DC.
 WIRING POINTS - 400 KC to 1610 KC.
 IF FREQ. - 262.5 KC.

MOTOROLA

MODEL
CTM9X

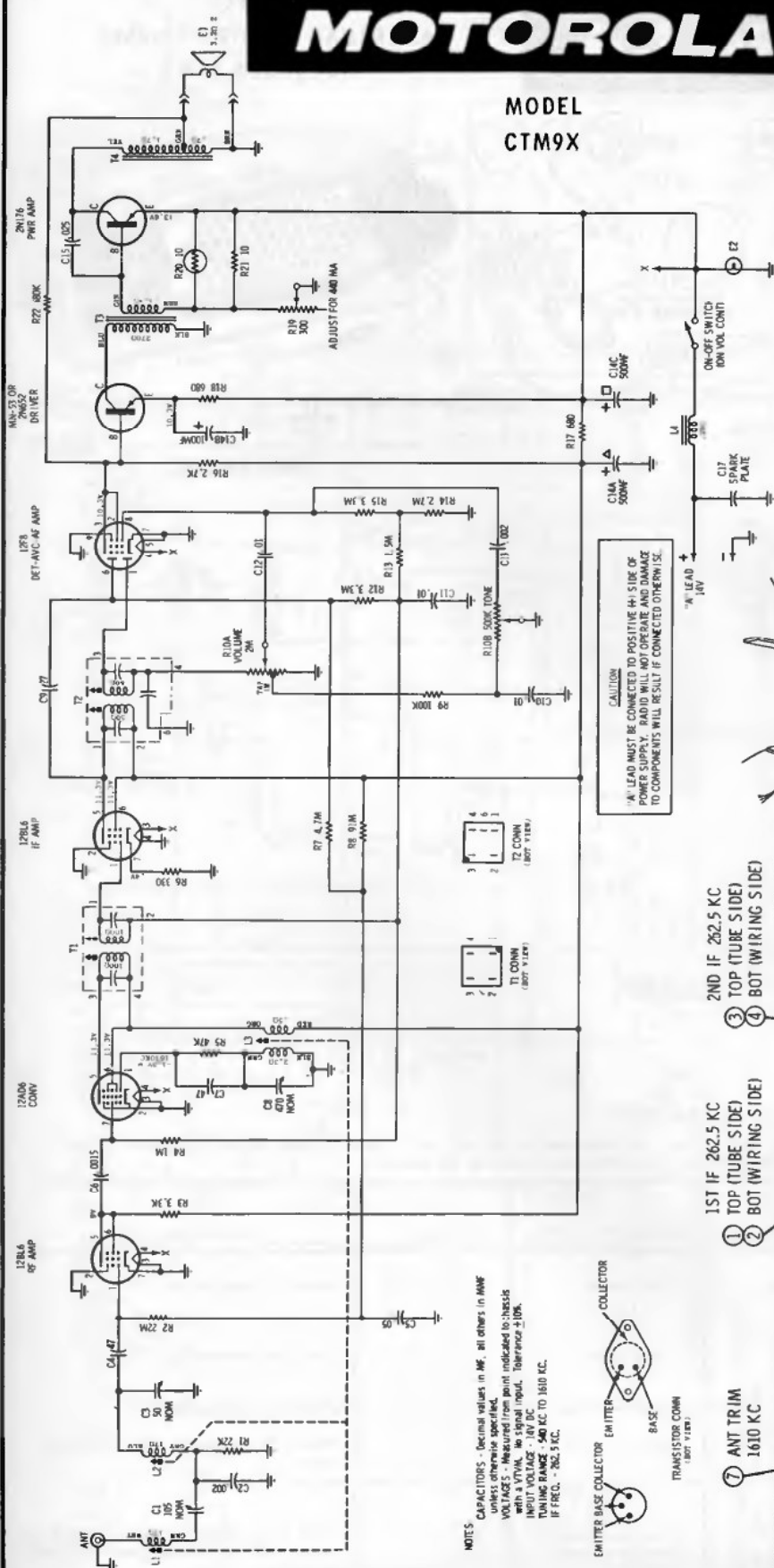

NOTES:
CAPACITORS - Decimal values in μ F. All others in M μ F unless otherwise specified.
VOLTAGES - Measured from point indicated to chassis with a VTVM. No signal input. Tolerance $\pm 10\%$.
TUNING RANGE - 540 KC TO 1610 KC.
IF FREQ. - 262.5 KC.



CAUTION
"A" LEAD MUST BE CONNECTED TO POSITIVE B+ SIDE OF POWER SUPPLY. BONDING WILL NOT OPERATE AND DAMAGE TO COMPONENTS WILL RESULT IF CONNECTED OTHERWISE.

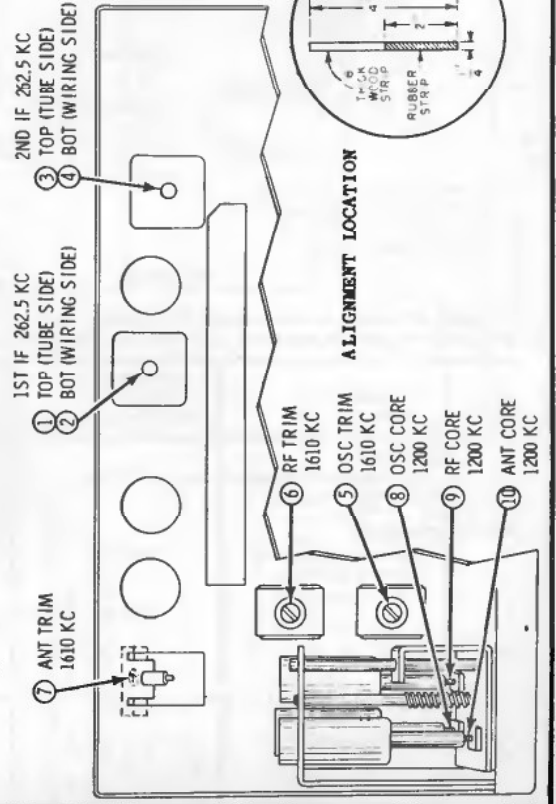

- 1 ANT TRIM 1610 KC
- 2 1ST IF 262.5 KC TOP (TUBE SIDE)
- 3 1ST IF 262.5 KC BOT (WIRING SIDE)
- 4 2ND IF 262.5 KC TOP (TUBE SIDE)
- 5 2ND IF 262.5 KC BOT (WIRING SIDE)
- 6 RF TRIM 1610 KC
- 7 OSC TRIM 1610 KC
- 8 OSC CORE 1200 KC
- 9 RF CORE 1200 KC
- 10 ANT CORE 1200 KC

ALIGNMENT LOCATION

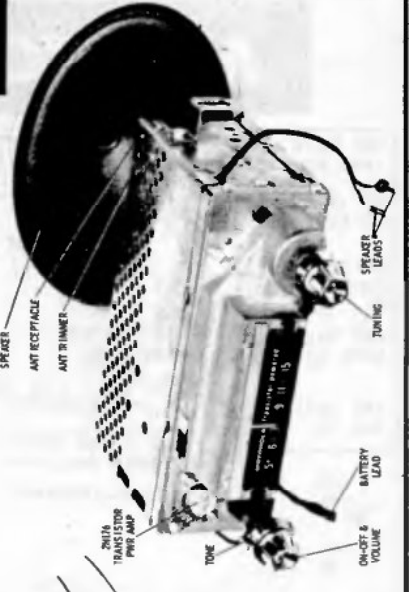

CORE ALIGNMENT TOOL DETAIL

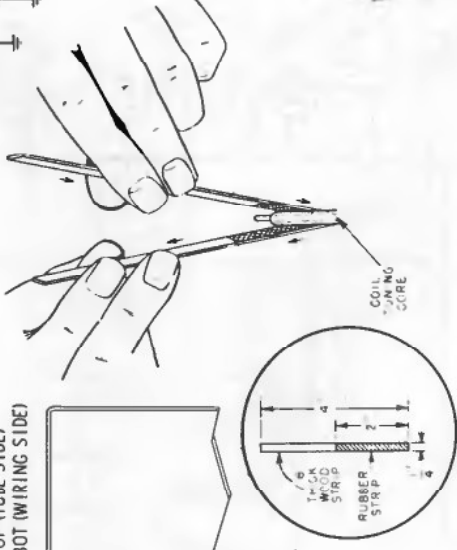



MODEL
AMERICAN MOTORS 8990582
MOTOROLA 93MR

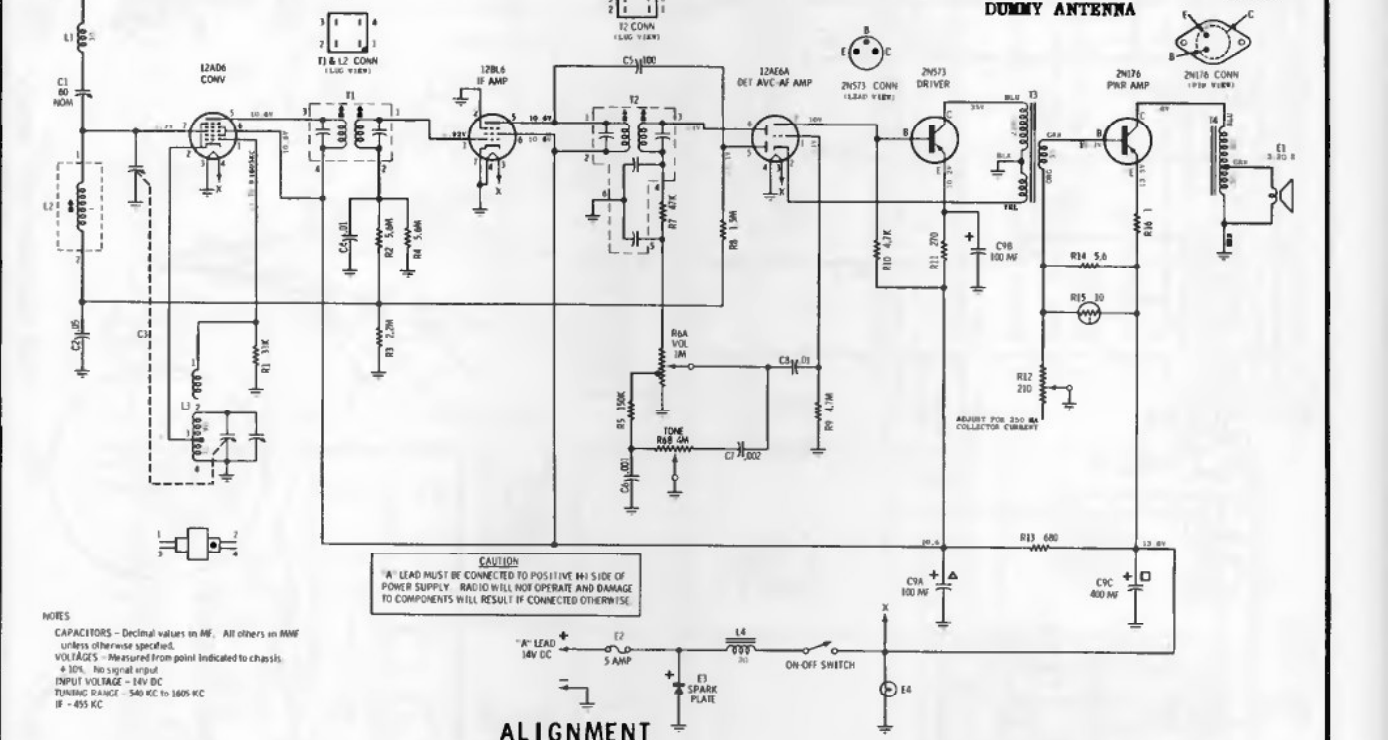
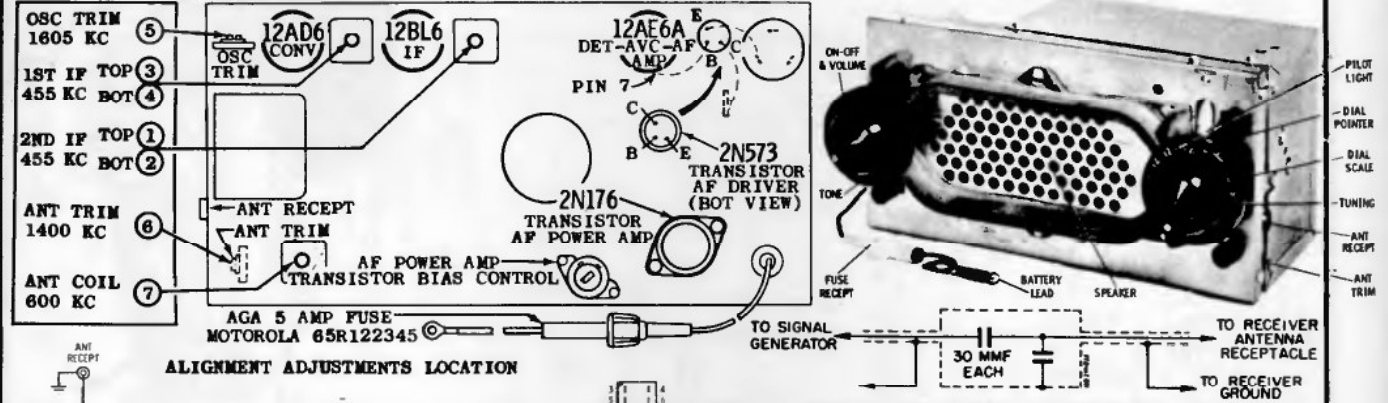

NOTES
CAPACITORS - Decimal values in MF. All others in MUF unless otherwise specified.
VOLTAGES - Measured from point indicated to chassis.
40K - No signal input.
INPUT VOLTAGE - 14V DC
TUNING RANGE - 540 KC to 1605 KC
IF - 455 KC

ALIGNMENT

Connect an output meter across the speaker voice coil. Set tone control to high and volume to maximum. Attenuate signal generator output to maintain 1.3 volts on output meter to prevent overloading the receiver.

| STEP | GENERATOR CONNECTION | GENERATOR FREQUENCY (400 cycle mod) | GANG SETTING | ADJUST | REMARKS |
|------------------------|--|-------------------------------------|---------------------------------------|-------------|---|
| IF ALIGNMENT | | | | | |
| 1. | Ant recept through .1 mf & chassis | 455 Kc | Fully open | 1, 2, 3 & 4 | Peak for maximum. |
| RF ALIGNMENT | | | | | |
| 2. | Ant recept through dummy antenna | 1605 Kc | Fully open | 5 | Peak for maximum. |
| 3. | " | 1400 Kc | Tune for max | 6 | Peak for maximum. |
| 4. | " | 600 Kc | Tune for max | 7 | Peak for maximum while rocking gang. |
| 5. | Repeat steps 3 & 4 until no further increase. The last adjustment should be the trimmer (6). | | | | |
| ANTENNA TRIMMER | | | | | |
| 6. | - | - | Tune to a weak station around 1400 Kc | 6 | With radio installed in car and antenna fully extended, peak antenna trimmer for max. |

MOTOROLA

MODELS
MOTOROLA 94MF, 94MFM
FORD B9FA-18806-C, B9FA-18805-E

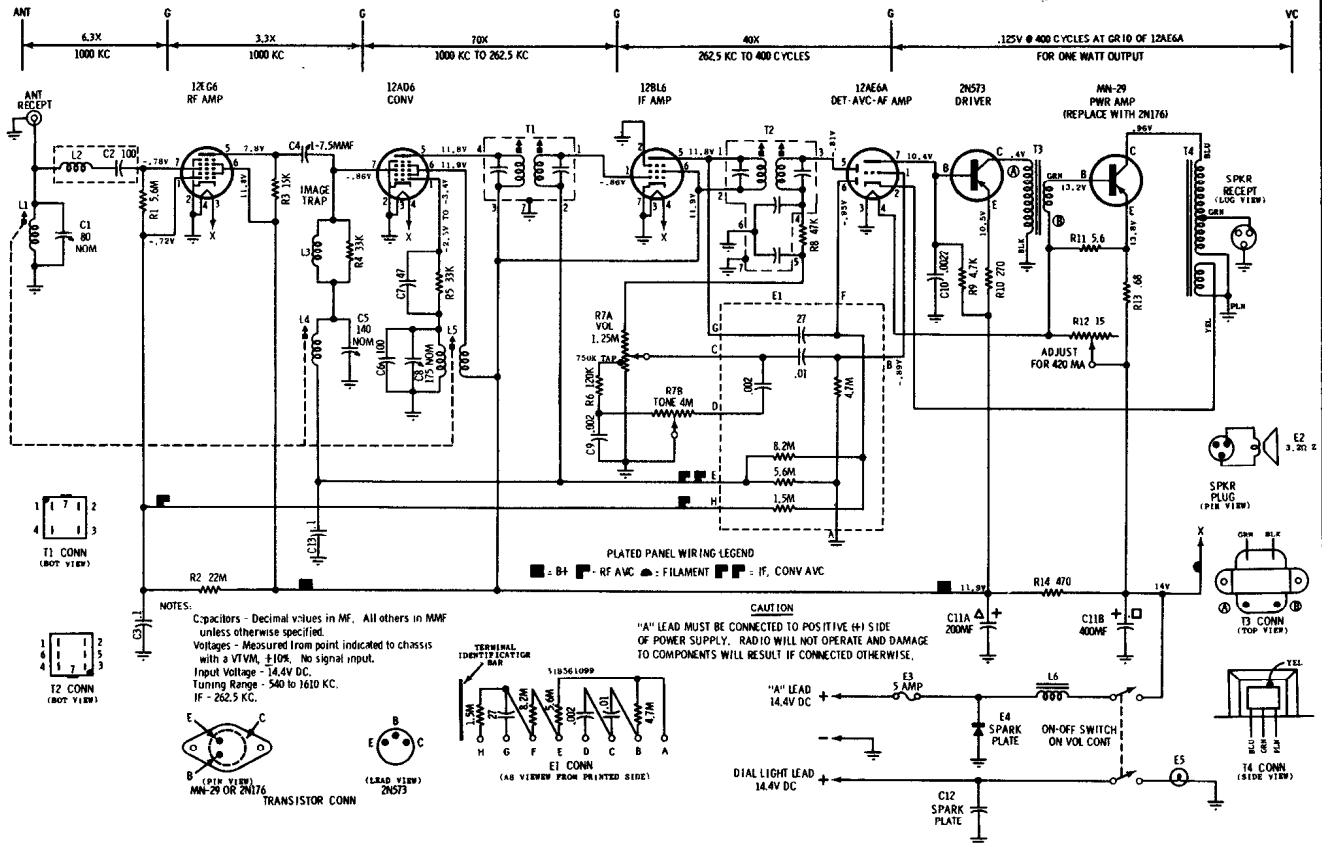

ALIGNMENT POINT LOCATION DETAIL

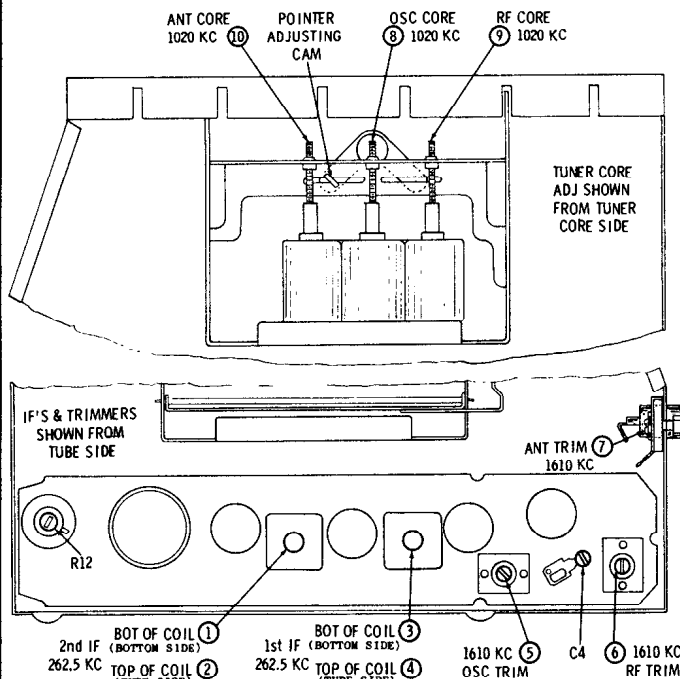

NOTE: Do not perform steps 3, 4, 5 & 6 unless tuner has been tampered with or components have been replaced. Before proceeding with step 3, back tuning cores 1-3/8" out of tuning coils to eliminate their effect on trimmer adjustment.

PLATED CIRCUIT COMPONENT REPLACEMENT

Most of the components can be removed from the panel with the aid of a soldering iron. When using a soldering pot, it may be difficult to dip some of the components close to the edge of the panel because of interference from the radio housing. To use a soldering pot on these components, it will be necessary to partially drop the panel from the housing, to do this proceed as follows:

- Remove two screws which hold radio housing to front plate (on volume control side of housing).
- Unsolder connecting lead from antenna spark choke at trimmer side.
- Unsolder plated panel support bracket from housing and panel, bend ears straight, and carefully remove from plated panel.
- Carefully remove plated panel from housing and drop below edge of housing.
- Replace screws removed from housing in step "a." so panel and housing will be more solid during soldering operation.

PLATED CHASSIS REMOVAL - If necessary to remove the plated panel completely from radio housing, proceed as follows:

- Remove two screws which hold radio housing to front plate (on volume control side of housing).
- Unsolder connecting leads to free panel. Where possible, avoid unsoldering leads at plated panel.
- Unsolder plated panel support bracket from housing and panel, bend ears straight, and carefully remove bracket from panel and housing.
- Plated panel will now be free for careful removal from housing.

MOTOROLA

**MODEL
MOTOROLA 95MF
FORD B9FA-18806-B**

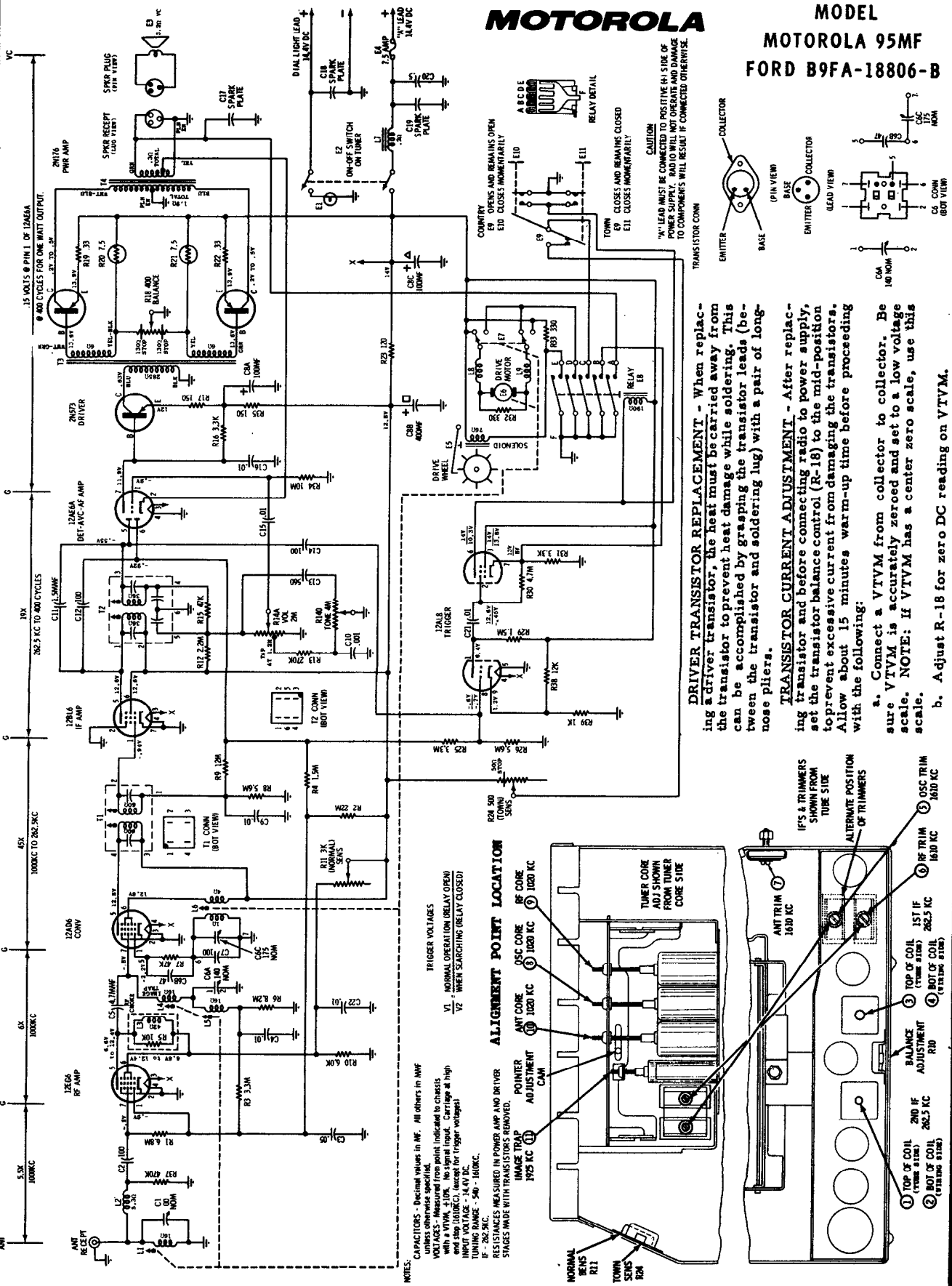

DRIVER TRANSISTOR REPLACEMENT - When replacing a driver transistor, the heat must be carried away from the transistor to prevent heat damage while soldering. This can be accomplished by grasping the transistor leads (between the transistor and soldering lug) with a pair of long-nose pliers.

TRANSISTOR CURRENT ADJUSTMENT - After replacing transistor and before connecting radio to power supply, set the transistor balance control (R-18) to the mid-position to prevent excessive current from damaging the transistors. Allow about 15 minutes warm-up time before proceeding with the following:

- Connect a VTVM from collector to collector. Be sure VTVM is accurately zeroed and set to a low voltage scale. NOTE: If VTVM has a center zero scale, use this scale.
- Adjust R-18 for zero DC reading on VTVM.

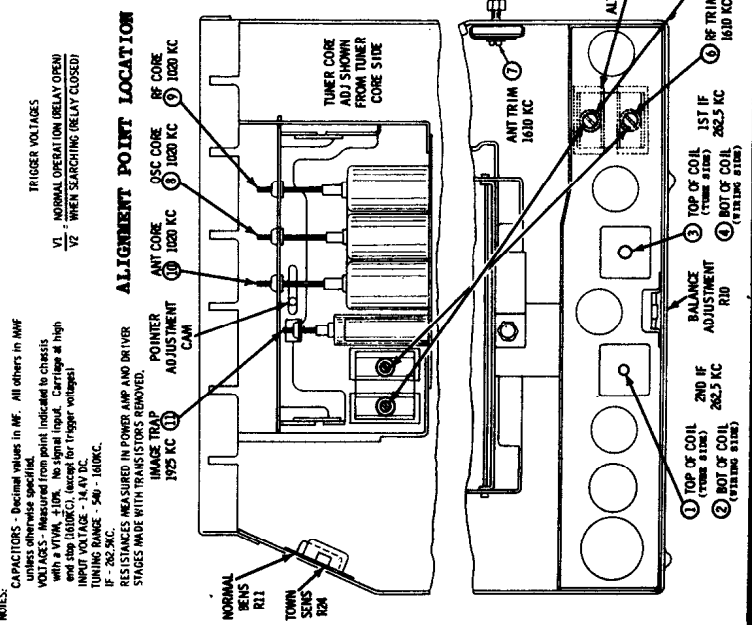

NOTES:

CAPACITORS - Decimal values in MF. All others in MMF unless otherwise specified.

RESISTORS - Values in ohms unless indicated by a suffix with a VITUM suffix. No signal input. (Capacitors at high end stop 1000KC). (except for trigger voltages).

INPUT VOLTAGE - 14.4V DC.

TUNING RANGE - 540 - 1610KC.

IF - 262.5KC.

RESISTANCES MEASURED IN POWER AMP AND DRIVER STAGES MADE WITH TRIGGER VOLTAGE APPLIED.

TRIGGER POINT LOCATION

V1 - NORMAL OPERATION (RELAY OPEN)

V2 - WHEN SEARCHING (RELAY CLOSED)

ALIGNMENT POINT LOCATION

ANT CORE 1795 KC

OSC CORE 1020 KC

RF CORE 1020 KC

ANT CORE 1020 KC

OSC TRIM 1630 KC

RF TRIM 1630 KC

1ST IF 262.5 KC

BALANCE ADJUSTMENT P.D.

TOP OF COIL (FROM STRIP)

BOT OF COIL (STRIP STRIP)

IF'S & TRIMMERS SHOWN FROM TUBE SIDE

ALTERNATE POSITION OF TRIMMERS

ANT TRIM 1630 KC

TUNER CORE ADJ. SHOWN FROM TUNER CORE SITE

NORMAL SENS R21

TOWN SENS R24



Models 300X and 301X

These are 12-volt sets designed for universal underdash installation. Model 300X, circuit on this page, is for use in cars with a negative ground electrical system. Model 301X, diagram on next page adjacent at right, is for cars with positive ground electrical system. Other material applies to both models.

NOTES:
 CAPACITORS - Decimal values in MF, all others in MMF unless otherwise specified.
 VOLTAGES - Measured from point indicated to chassis with a VTVM. No signal input. Tolerance $\pm 10\%$.
 INPUT VOLTAGE - 14V DC.
 TUNING RANGE - 540 KC TO 161D KC.
 IF FREQ. - 262.5 KC.

MODEL 300X SCHEMATIC DIAGRAM

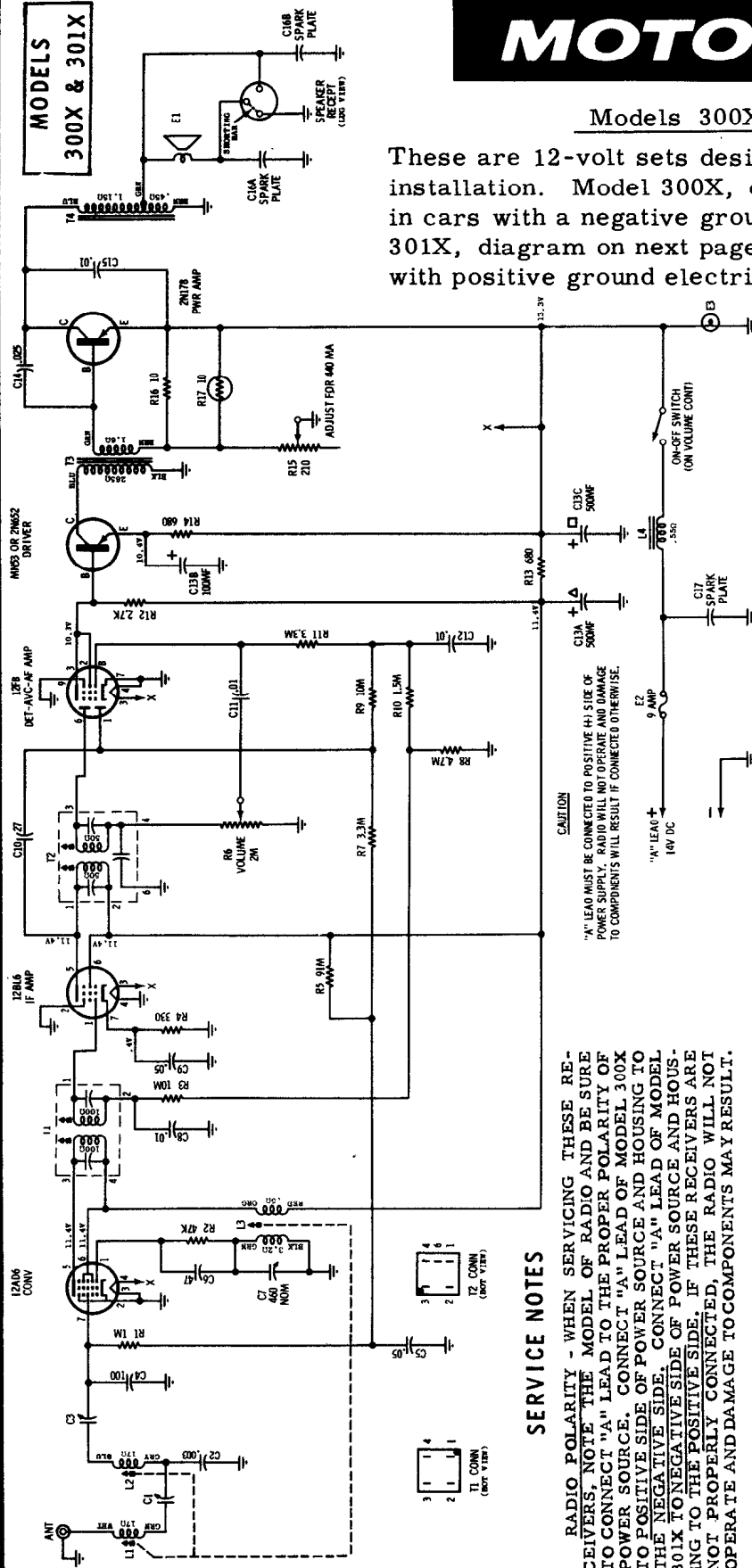

SERVICE NOTES

RADIO POLARITY - WHEN SERVICING THESE RECEIVERS, NOTE THE MODEL OF RADIO AND BE SURE TO CONNECT "A" LEAD TO THE PROPER POLARITY OF POWER SOURCE. CONNECT "A" LEAD OF MODEL 300X TO POSITIVE SIDE OF POWER SOURCE AND HOUSING TO THE NEGATIVE SIDE. CONNECT "A" LEAD OF MODEL 301X TO NEGATIVE SIDE OF POWER SOURCE AND HOUSING TO THE POSITIVE SIDE. IF THESE RECEIVERS ARE NOT PROPERLY CONNECTED, THE RADIO WILL NOT OPERATE AND DAMAGE TO COMPONENTS MAY RESULT.

POWER SUPPLY REQUIREMENTS - It is preferable to use a storage battery (without a battery charger) in place of a battery eliminator when servicing this receiver, because the average eliminator has an extremely high AC ripple content which may damage the transistor and other low voltage components.

POWER TRANSISTOR CURRENT ADJUSTMENT - After a power transistor has been replaced, the collector current should be checked and adjusted for proper operation.

- Connect a 0-3 amp DC ammeter in series with the "A" lead.
- Remove output transistor from its socket.
- Turn radio on and read ammeter with 12.6 volts input to "A" lead (approximately 800 ma). **NOTE READING.**
- Turn radio off and replace transistor.
- Turn radio on and adjust R-15 for a 360 ma increase over reading noted in step c with 12.6 volts input to "A" lead.

NOTE: Two values of radio input voltage are given as a convenience to service personnel in order to accommodate different power sources. The current value of 440 ma stated on the schematic is for 14 volts DC input to receiver "A" lead.

POWER TRANSISTOR INSULATOR - When replacing a power transistor or power transistor insulator, be sure to coat both sides of insulator with DC-4 grease (Motorola Part No. 11M490487) to insure proper heat dissipation.

TRANSISTOR CHECK - The transistors used in this receiver can be expected to give unusually long trouble-free life. However, the following transistor checks are provided to facilitate servicing:

Substituting a known good transistor for a suspected one is the simplest and most positive way of checking transistors. When a transistor is not available for substitution, make a resistance check of the stage. If the values are within the tolerance rating, the bias network can be eliminated as a source of defect and the transistor safely suspected. Bias network defects can be located by resistance checks.

CAUTION
 "A" LEAD MUST BE CONNECTED TO POSITIVE (+) SIDE OF POWER SUPPLY. RADIO WILL NOT OPERATE AND DAMAGE TO COMPONENTS WILL RESULT IF CONNECTED OTHERWISE.

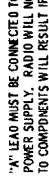

MOTOROLA Models 300X and 301X, Continued

This page has the circuit of Model 301X, and other service material that is applicable to both 300X and 301X. See also the material on previous page, at left.

MODEL 301X SCHEMATIC DIAGRAM

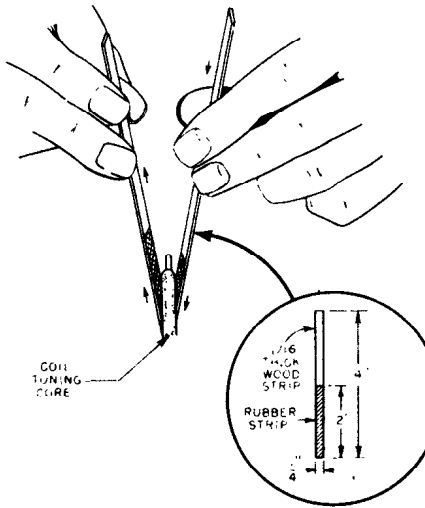
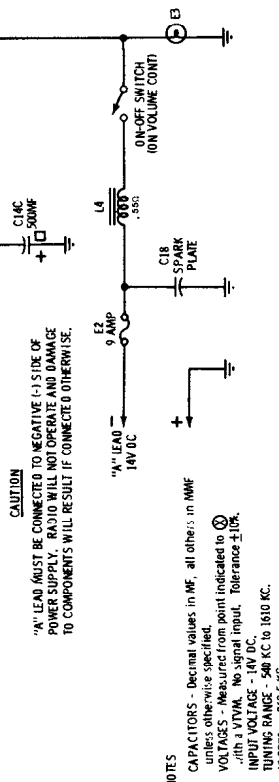
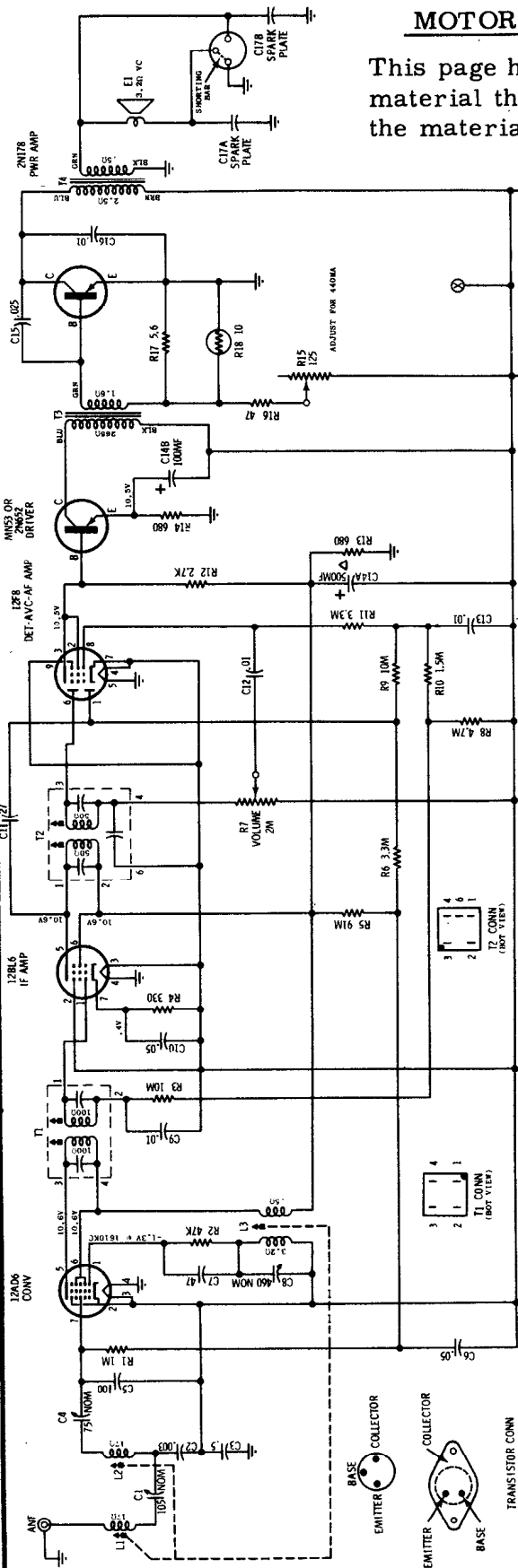

CORE ALIGNMENT TOOL DETAIL

NOTES
 CAPACITORS - Decimal values in MF, all others in MMF unless otherwise specified.
 VOLTAGES - Measured from point indicated to 0 with 3 MVVM. No signal input. Tolerance $\pm 10\%$.
 INPUT VOLTAGE - 14V DC.
 TUNING RANGE - 540 KC to 1610 KC.
 IF FREQ. - 262.5 KC.

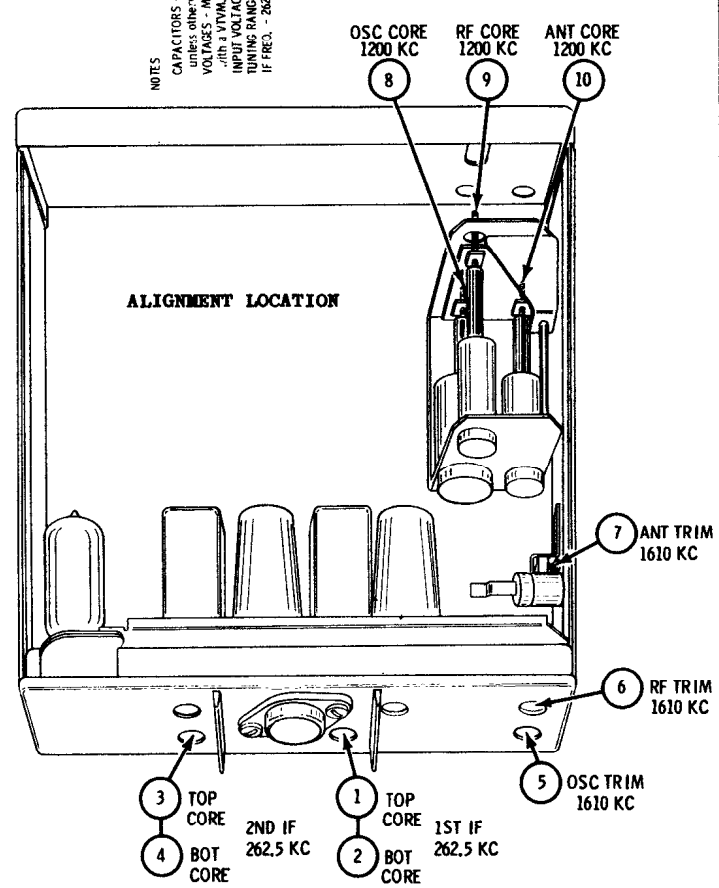

MOTOROLA

MODEL
406

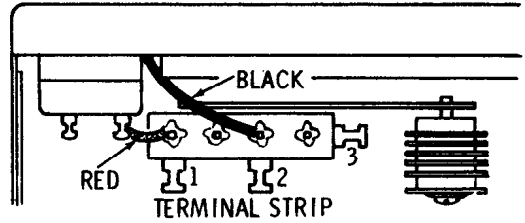

RADIO WIRING FOR CARS WITH A NEGATIVE GROUND ELECTRICAL SYSTEM - RED LEAD MUST BE SOLDERED TO TERMINAL NO. 1: BLACK LEAD TO TERMINAL NO. 2.

RADIO POLARITY - BEFORE CONNECTING RADIO TO A 6 VOLT POWER SOURCE, REMOVE BOTTOM COVER AND CHECK POLARITY WIRING AGAINST DETAIL. THEN CONNECT RADIO TO POWER SOURCE PER DETAIL. IF THIS RECEIVER IS NOT PROPERLY CONNECTED, IT WILL NOT OPERATE AND DAMAGE TO COMPONENTS MAY RESULT.

OUTPUT TRANSISTOR CURRENT ADJUSTMENT - After an output transistor has been replaced, the collector current should be checked and adjusted for proper operation.

- Connect a 3 amp DC ammeter in series with the "A" lead.
- Remove output transistor from its socket.
- Turn radio on and read ammeter with 6.3 volts input to "A" lead (approximately 2.0 amp). **NOTE READING.**
- Turn radio off and replace transistor
- Turn radio on and adjust R-14 for a 600 ma increase over reading noted in step c with 6.3 volts input to "A" lead.

NOTE: Two values of radio input voltage are given as a convenience to service personnel in order to accommodate different power sources. The current value of 720 ma stated on the schematic is for 7 volts DC input to receiver "A" lead.

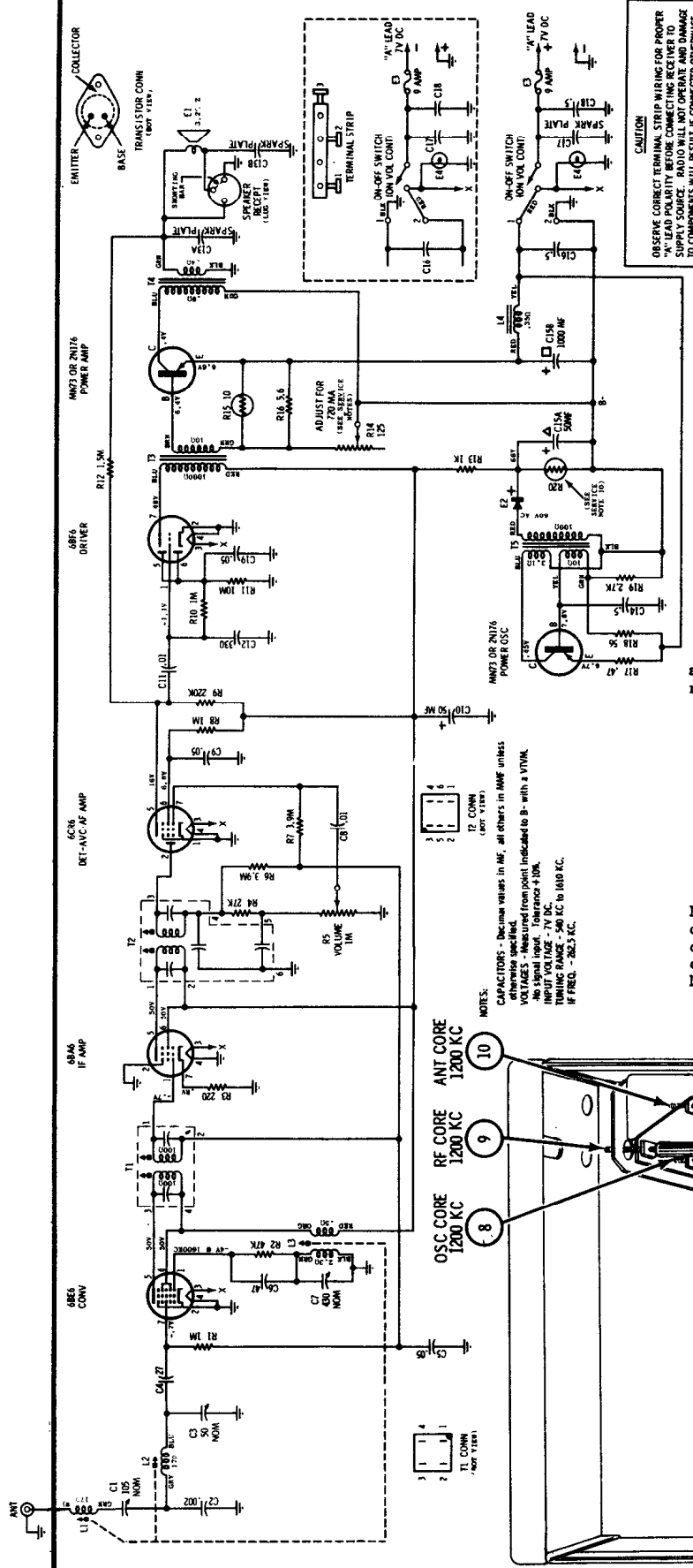

NOTES:
 CAPACITORS - The main values in mf, all others in mmf unless otherwise specified.
 VOLTAGES - Measured from point indicated to B- with a VTVM.
 No signal input. Tolerance +10%.
 INPUT VOLTAGE - 7V DC.
 TUNING RANGE - 540 KC to 1610 KC.
 IF FREQ. - 262.5 KC.

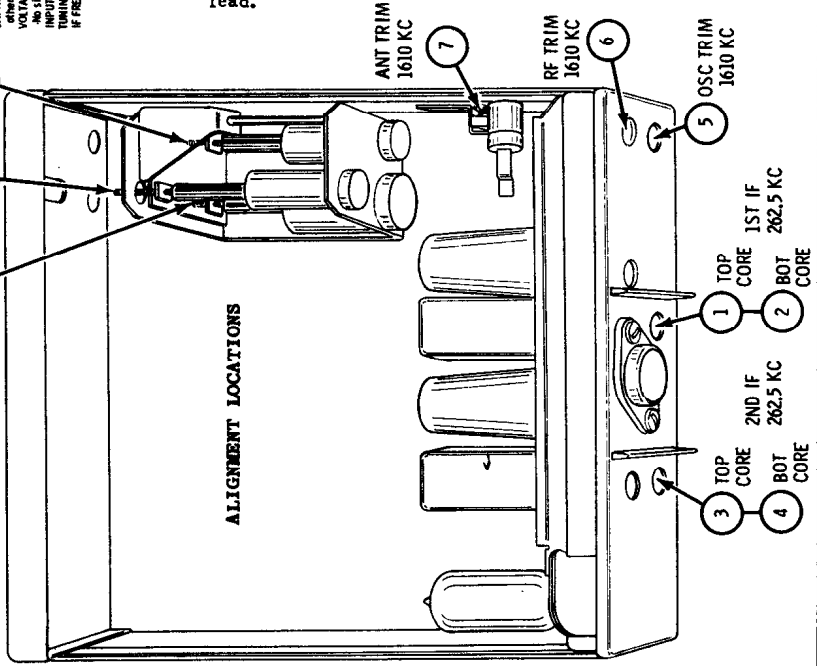

ALIGNMENT LOCATIONS

MOTOROLA

MODEL
GV-701

TRANSISTOR CURRENT ADJUSTMENT - After replacing a transistor, the collector current must be adjusted to insure proper operation of the output stage. Adjustment of the collector current must be made within one minute after the receiver has been turned on - before it has time to warm up. If the receiver is warm from operation, it will have to be cooled before adjusting the collector current.

A. Set R-21 to maximum resistance position (fully counter-clockwise when viewed from the wiring side) so that the new transistor does not draw excessive collector current and "run away".

B. Unsolder output transformer (T-4) black lead and grounded speaker lead from chassis; connect the two leads together. Be sure speaker is connected while making adjustment; volume control must be set to minimum. Connect the positive side of a 0 - 1.0 amp DC ammeter to the two leads just removed and the negative side to chassis. The

meter used must have an internal resistance of .05 ohms or less; if higher, meter will act as a current limiter and cause an incorrect adjustment.

C. Adjust R-21, within one minute, after turning on a cold receiver for a total collector current reading of 160 ma with 12.6 volts input to receiver's "A" lead. Resolder two leads to chassis after adjustment.

NOTE: Two values of receiver input voltage are given as a convenience to service personnel to accommodate different power sources. The schematic total collector current value of 200 ma is stated with 14 volts DC input to receiver's "A" lead.

POWER TRANSISTOR INSULATOR - When replacing a power transistor or power transistor insulator, be sure to coat both sides of insulator with DC-4 grease (Motorola Part No. 11M490487) to insure proper heat dissipation.

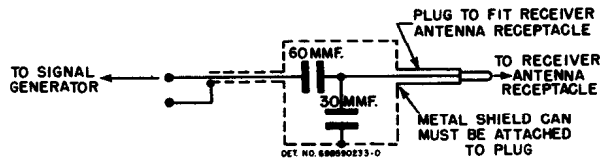

DUMMY ANTENNA DETAIL

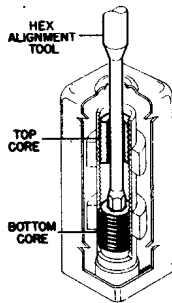

IF ALIGNMENT DETAIL

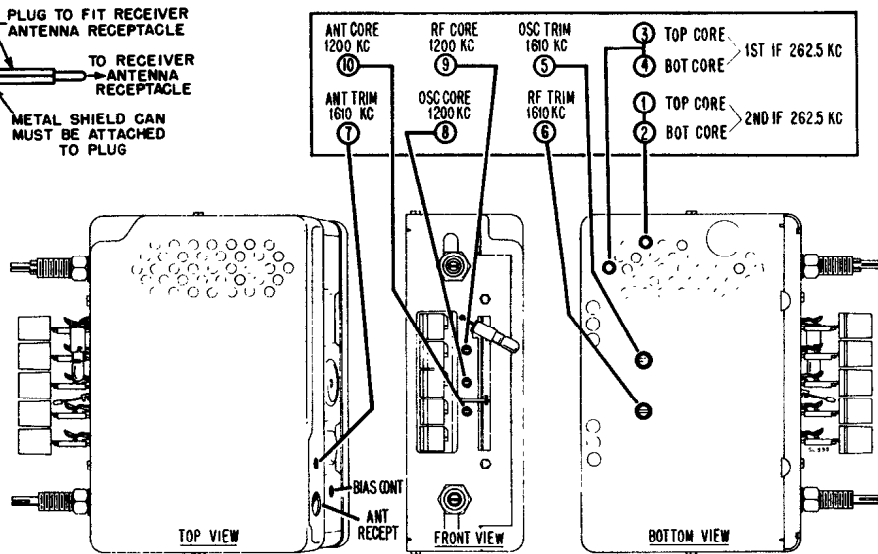

ALIGNMENT POINT LOCATIONS DETAIL

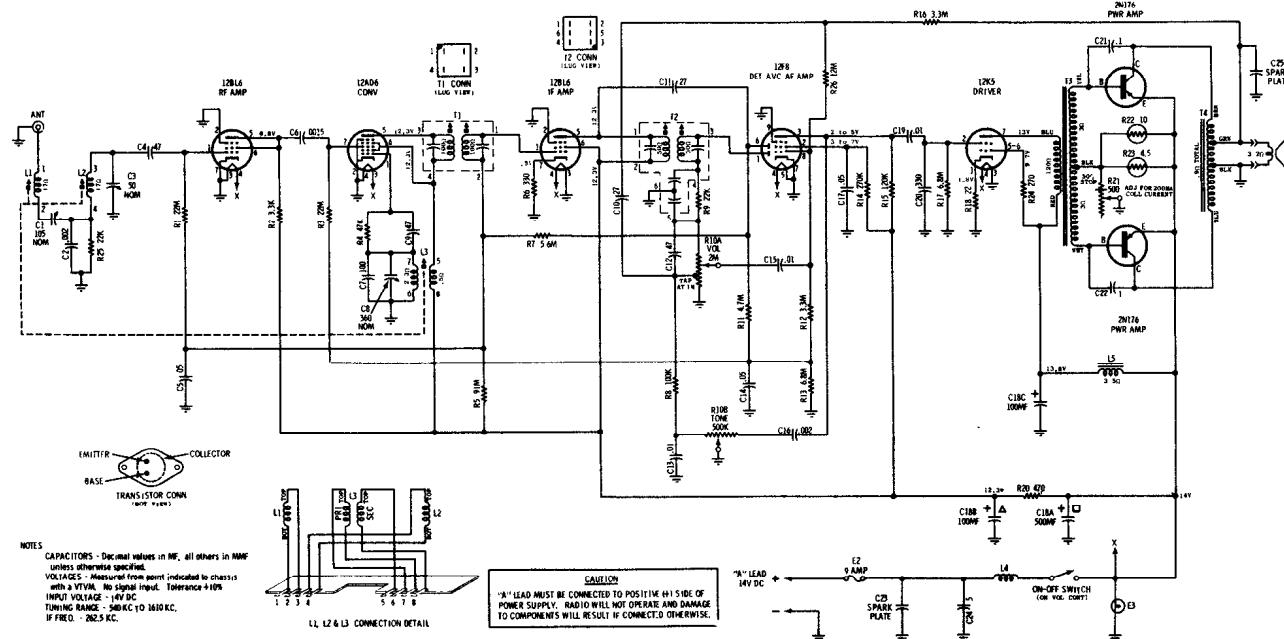



Auto Radio Model GV-800
(Continued on the next page at right)

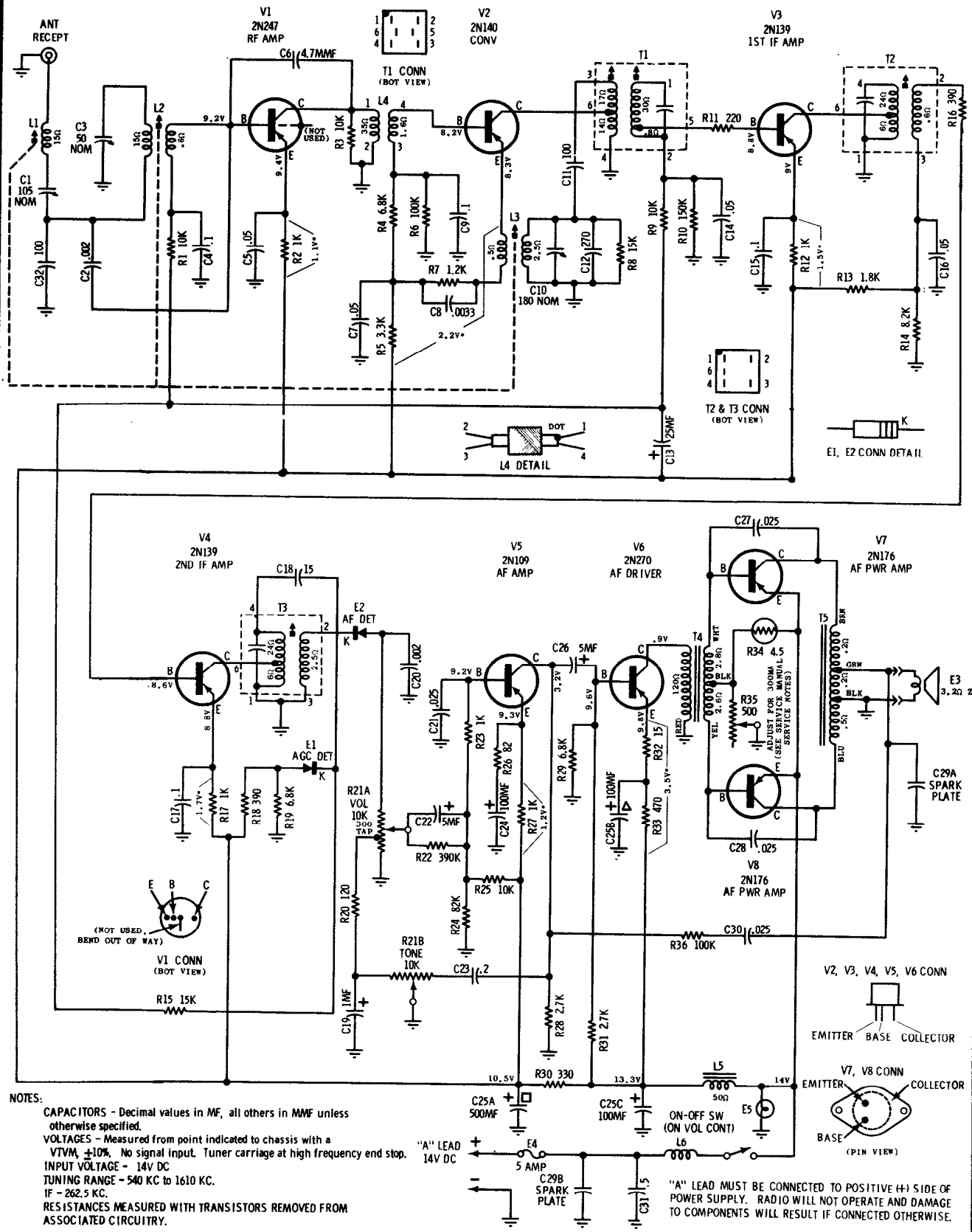

NOTES:
 CAPACITORS - Decimal values in MF, all others in MMF unless otherwise specified.
 VOLTAGES - Measured from point indicated to chassis with a VTVM, $\pm 10\%$. No signal input. Tuner carriage at high frequency end stop.
 INPUT VOLTAGE - 14V DC
 TUNING RANGE - 540 KC to 1610 KC.
 IF - 262.5 KC.
 RESISTANCES MEASURED WITH TRANSISTORS REMOVED FROM ASSOCIATED CIRCUITRY.

"A" LEAD
 14V DC
 5 AMP
 C29B SPARK PLATE
 C31 15
 ON-OFF SW (ON VOL CONT)
 L6
 "A" LEAD MUST BE CONNECTED TO POSITIVE (+) SIDE OF POWER SUPPLY. RADIO WILL NOT OPERATE AND DAMAGE TO COMPONENTS WILL RESULT IF CONNECTED OTHERWISE.

MOTOROLA

| MODELS | CHASSIS |
|--------|---------|
| 5P21B | HS-633 |
| 5P21N | HS-633 |
| 5P21R | HS-633 |

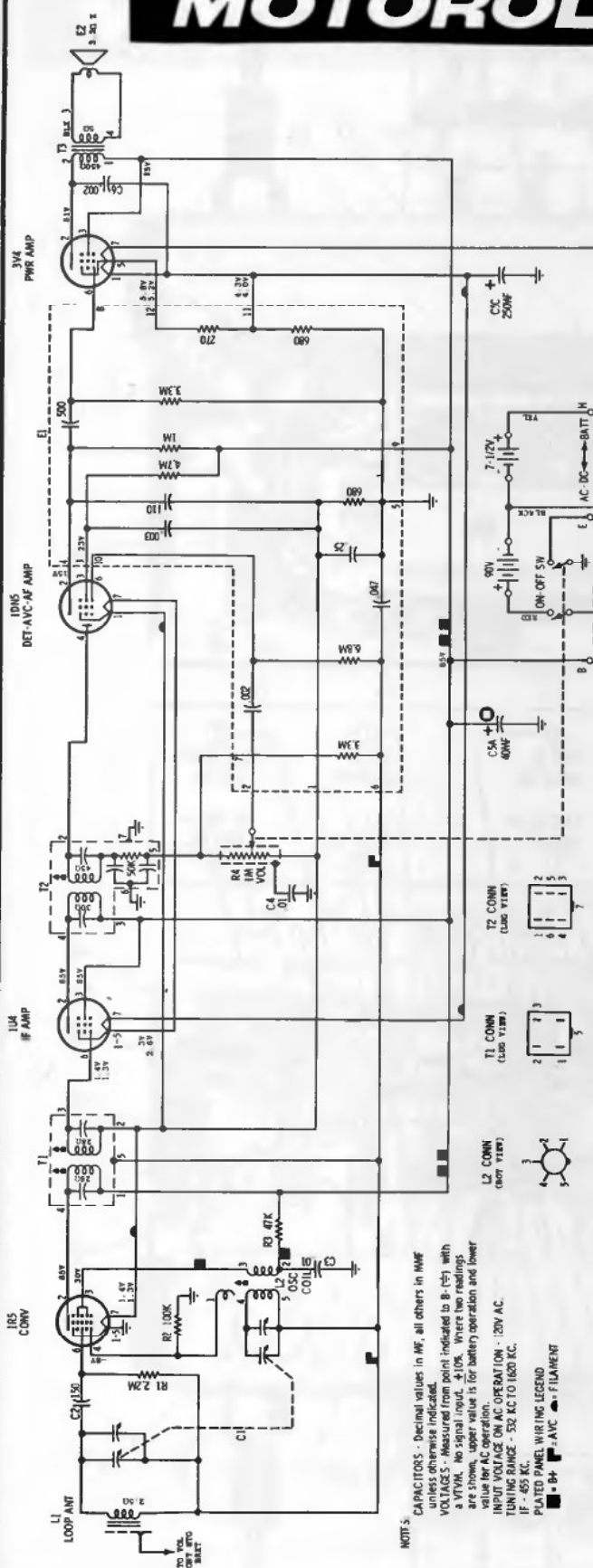

NOTE: CAPACITORS - Decimal values in μ F, all others in MMF unless otherwise indicated.
 VOLTAGES - Measured from point indicated to B- (5V) with a VTVM. No signal input. \pm 10%. Where two readings are shown, upper value is for battery operation and lower value for AC operation.
 INPUT VOLTAGE ON AC OPERATION: 120V AC.
 TUNING RANGE - 532 KC TO 1620 KC.
 IF - 455 KC.
 PLATED PANEL WIRING LEGEND
 ■ - B+ □ - AVC ▲ - FILAMENT

| COMPONENT | VALUE | ALIGNMENT POINT |
|-----------|---------|-----------------|
| 2ND IF | 455 KC | ① |
| 1ST IF | 455 KC | ② |
| TOP BOT | | ③ |
| ANT TRIM | 1400 KC | ④ |
| OSC TRIM | 1620 KC | ⑤ |
| OSC CORE | 532 KC | ⑥ |

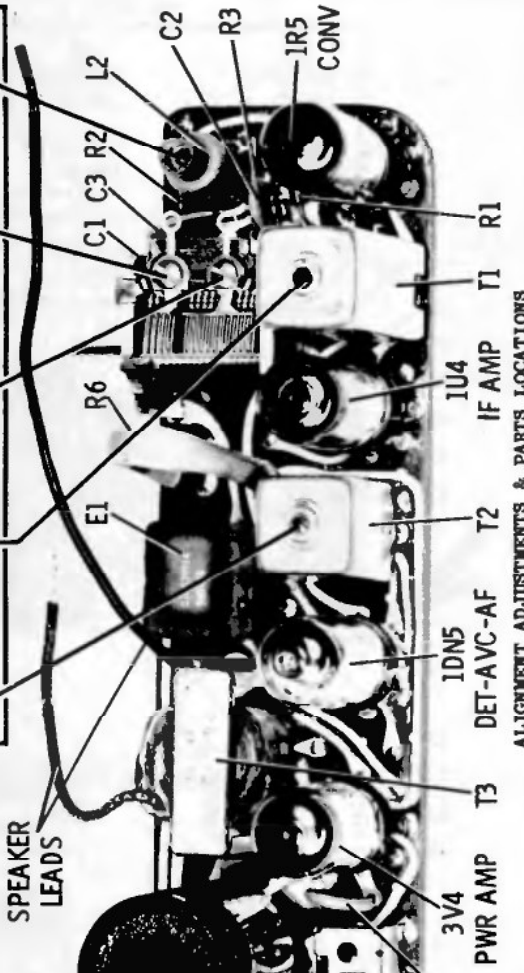

TO REMOVE CHASSIS FROM CABINET

1. Pull the control knobs from front of radio.
2. Remove the volume control mounting palmnut and the machine screws under tuning knob of radio.
3. Unsolder speaker leads.
4. Unsolder antenna leads.
5. Remove chassis from cabinet.

MOTOROLA

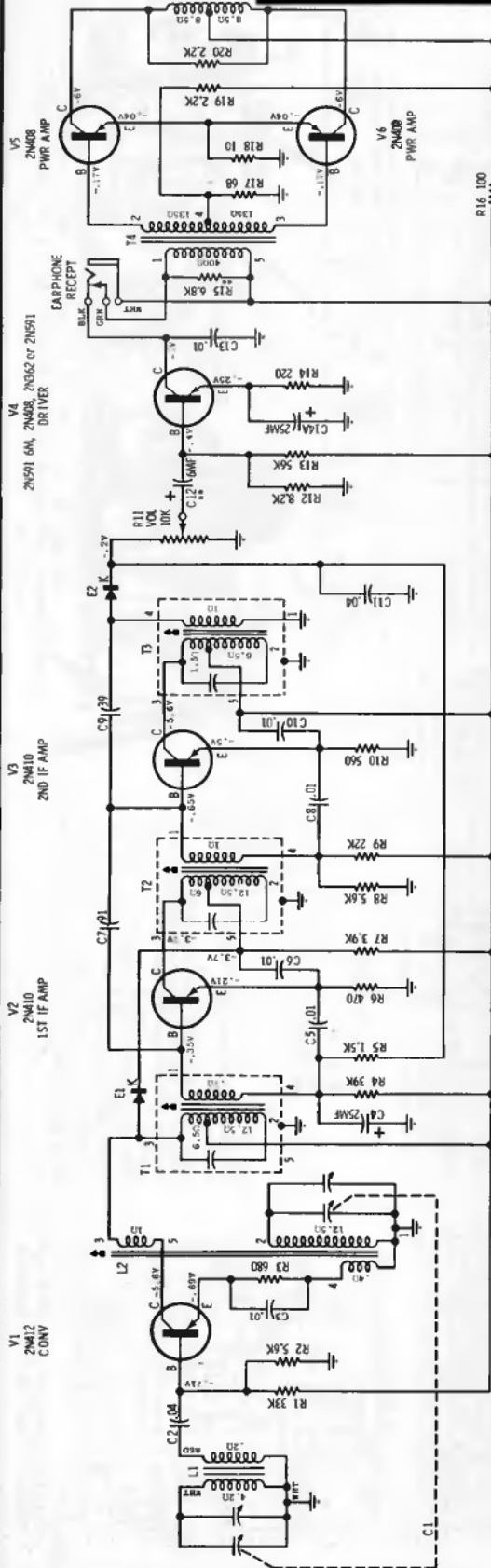

MOTOROLA

MODELS
 6X28B
 6X28N
 6X28P
 6X28W

CHASSIS
 HS-638
 HS-638
 HS-638
 HS-638

Power 8 Series

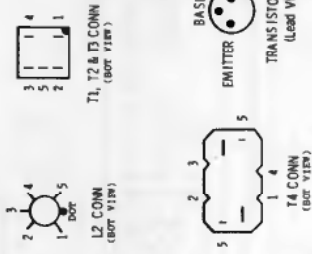

PLATED PANEL CHASSIS REMOVAL

1. Remove cabinet back by inserting a coin into the cover opening slot and twisting until cabinet back is free.
2. Remove earphone jack mounting nut and washer.
3. From inside cabinet, remove batteries.
4. Remove battery contact panels by pulling straight out (note position of rounded corners on panels to insure correct positioning when chassis is replaced later).
5. Spread cabinet slightly at top and bottom (points A & B) until chassis is free of chassis retainers (C & D) at top and bottom of cabinet; then lift up chassis at speaker end of cabinet until it clears the chassis retainers (C & D).
6. Lift chassis up until it is slightly above speaker, then slide chassis over speaker so that the chassis is free of chassis retainers (E & F) below earphone jack.
7. From under chassis, loosen speaker mounting screws until speaker mounting brackets are loose enough so that the speaker can be removed.
8. Lift chassis, speaker, and battery contact panels out of cabinet.
9. Before replacing chassis, mount speaker, then insert tuning gang end of chassis into cabinet, spread points A & B of cabinet, then lower other end of chassis into place under chassis retainers C & D (make certain battery leads are dressed under and away from antenna).
10. Place battery contact panels back into the cabinet slots with rounded corners of each panel facing in the same direction as originally found.

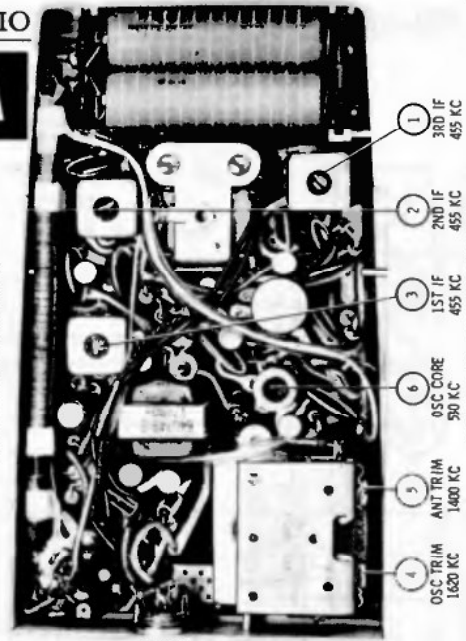

ALIGNMENT POINT LOCATIONS

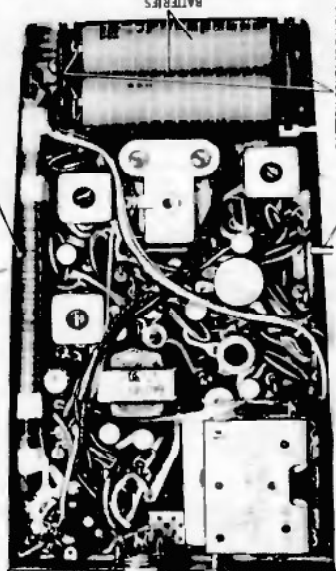

REMOVAL OF PLATED PANEL CHASSIS

MOTOROLA

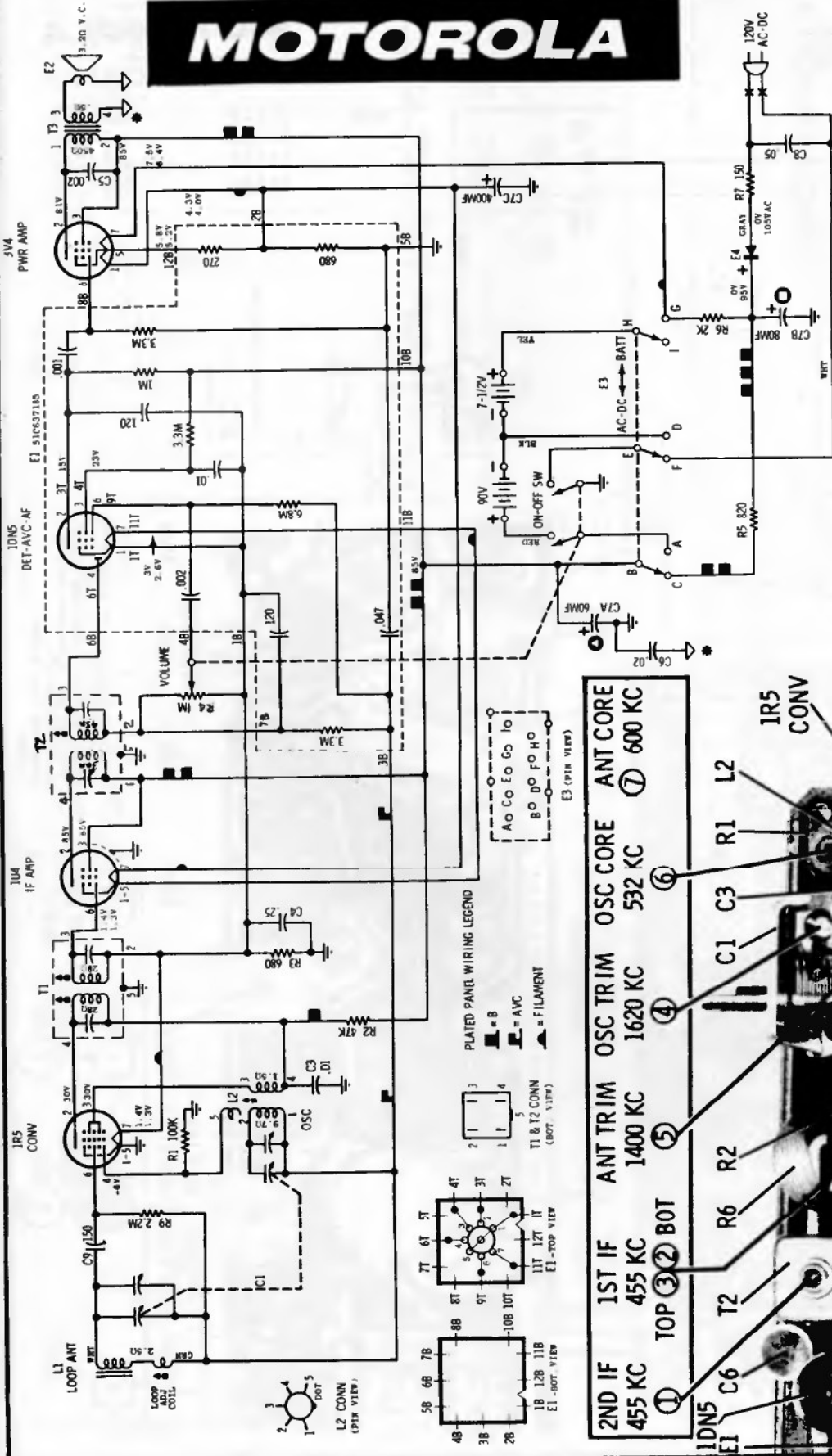

MOTOROLA

| MODELS | CHASSIS |
|----------|---------|
| 5P22GW-1 | HS-647 |
| 5P22RW-1 | HS-647 |
| 5P22S-1 | HS-647 |
| 5P23E-1 | HS-647 |
| 5P23PN-1 | HS-647 |
| 5P23WB-1 | HS-647 |

NOTES: CAPACITORS - Decimal values in MF, all others in MMF unless otherwise specified.
 VOLTAGE S - Measured from point indicated to ground with a VTVM. No signal input.
 10% tolerance. Where two voltage readings are shown, upper value is for battery operation and bottom value for AC operation.
 INPUT VOLTAGE ON AC OPERATION - 120VAC.
 TUNING RANGE - 532 KC to 1620 KC.
 IF - 455 KC.
 ⚡ = B+; ⤴ = Ground to cabinet
 * Ground to cabinet thru volume control mounting bushing.

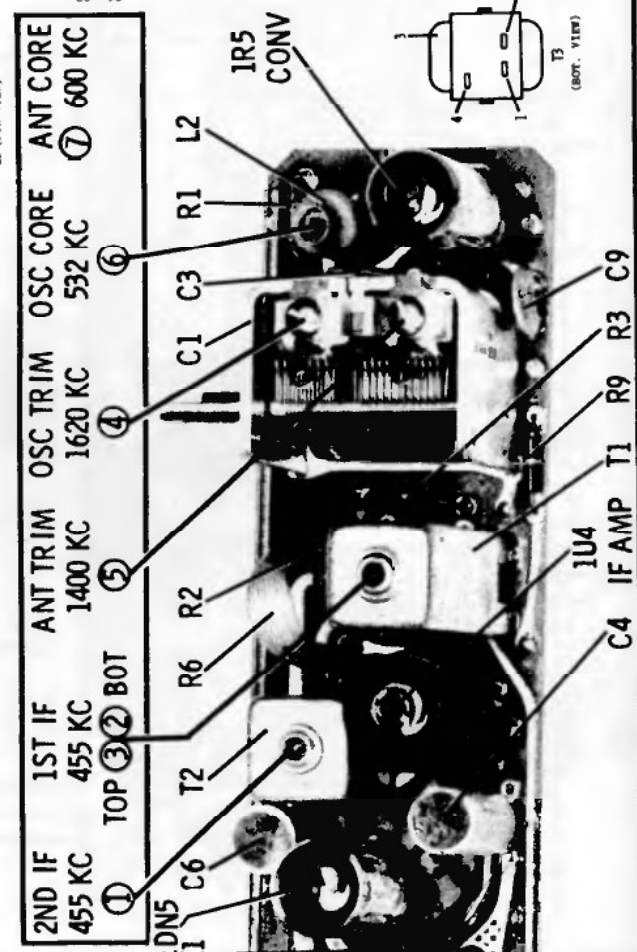
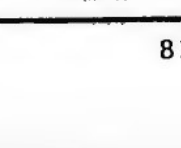
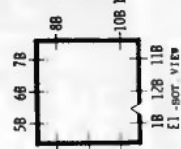
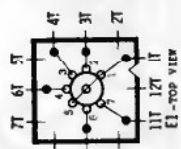
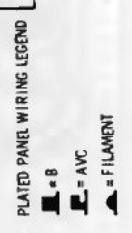

VOLUME R-19, MOST-OFTEN-NEEDED 1959 RADIO SERVICING INFORMATION

MOTOROLA

| MODELS | CHASSIS |
|--------|---------|
| 5T12B | HS-653 |
| 5T12M | HS-653 |
| 5T12P | HS-653 |
| 5T12W | HS-653 |
| 5T13P | HS-654 |
| 5T13S | HS-654 |
| 5T14GW | HS-654 |
| 5T14W | HS-654 |

NOTES:
 CAPACITORS - Decimal values in MF, all others in MMF unless otherwise specified.
 VOLTAGES - Measured from point indicated to B- with a VTVM, +10%. No signal input. Line voltage maintained at 120V AC.
 INPUT VOLTAGE - 120V AC/DC.
 TUNING RANGE - 535 KC TO 1620 KC.
 IF - 455 KC.
 ⇨ = CABINET BACK ⚡ = B-

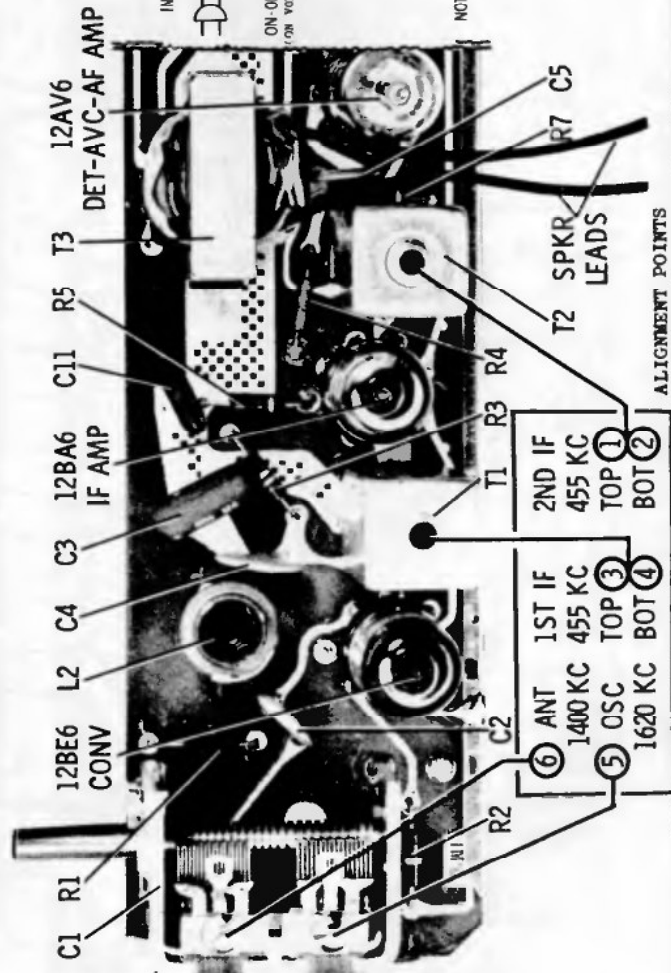
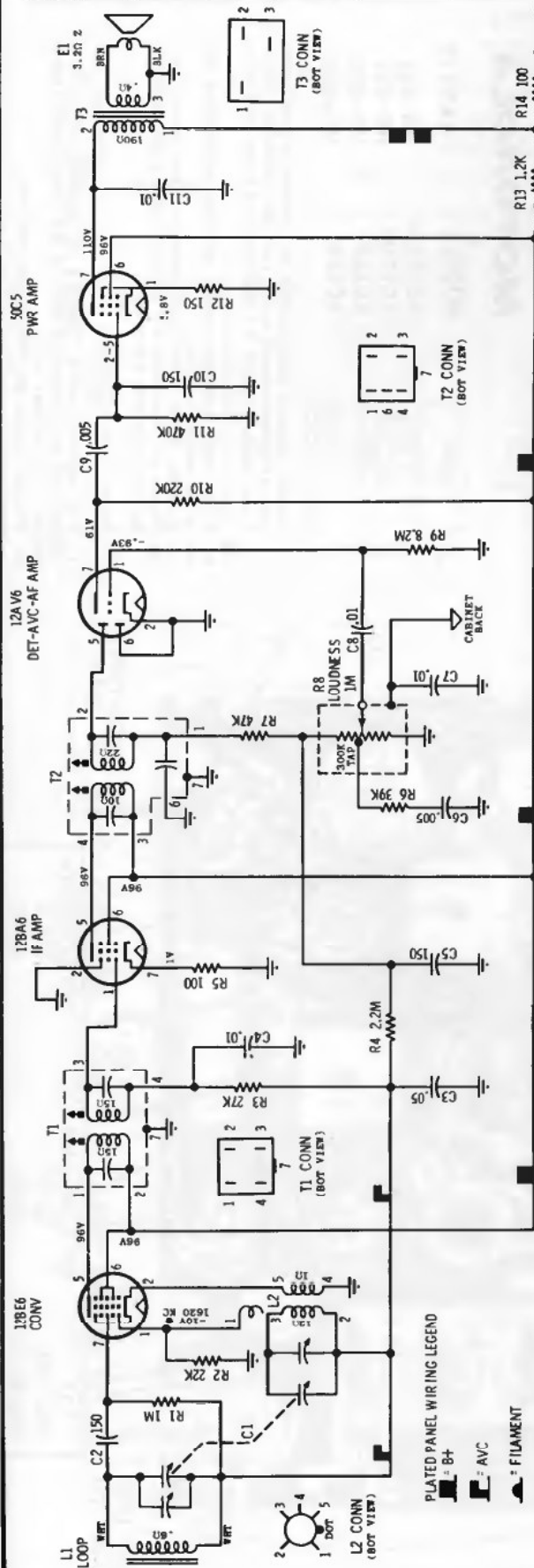

PLATED PANEL WIRING LEGEND
 ■ = B+
 □ = AVC
 ▲ = FILAMENT

MOTOROLA

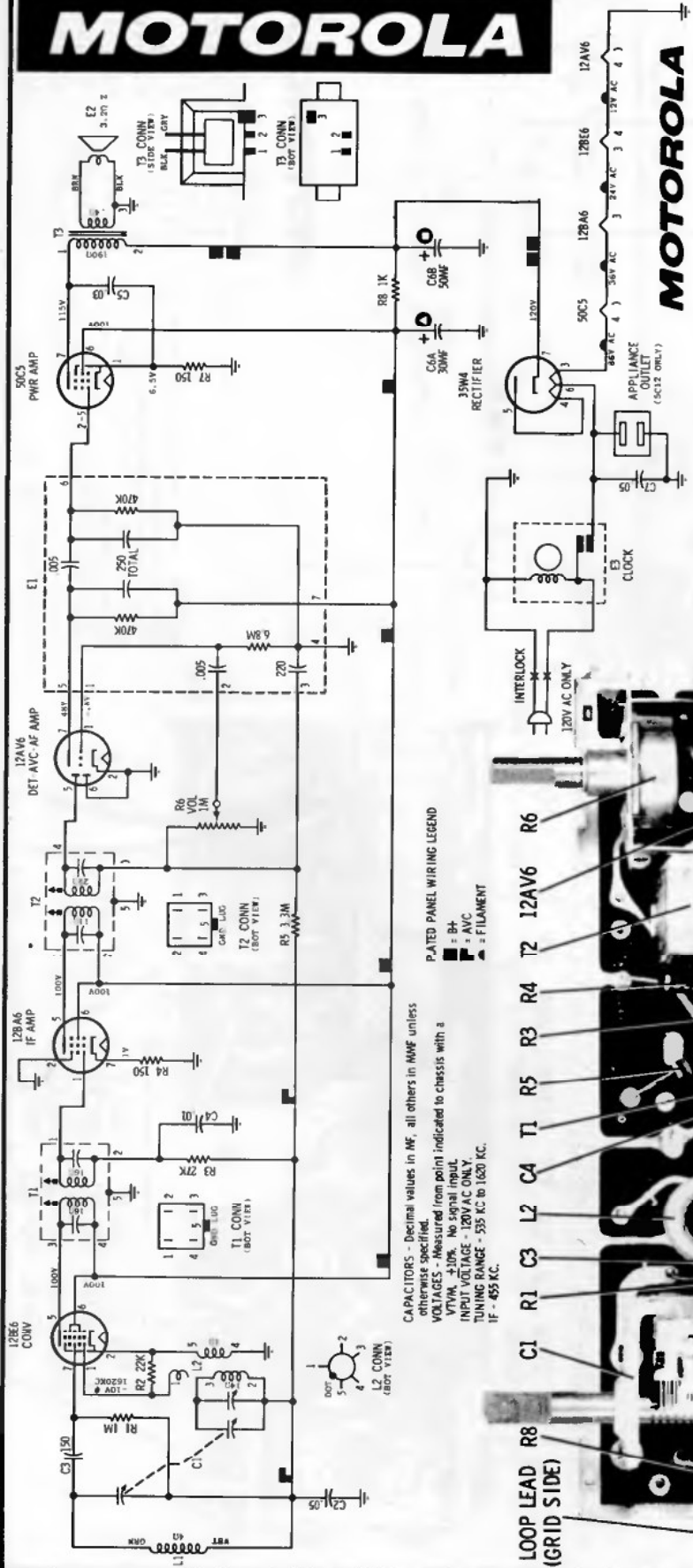

MOTOROLA

| MODELS | CHASSIS |
|--------|---------|
| 5C11E | HS-658 |
| 5C12M | HS-658 |
| 5C12P | HS-658 |
| 5C12W | HS-658 |



To Remove Chassis

1. Remove cabinet back screws and remove cabinet back.
2. Pull off the two control knobs from the front of the radio.
3. From front, remove the Phillips head screw near tuning shaft.
4. From rear, remove chassis mounting screw from the rear of the volume control.
5. Unsolder power leads from connector strip located behind clock and also unsolder speaker leads from speaker.
6. Remove chassis from cabinet.

To Remove Clock Crystal

1. Pull off clock knobs. Insert a screwdriver between the cabinet and the right-hand edge of the clock crystal (near number 3) to release catch.
2. Pry the crystal out with the screwdriver.

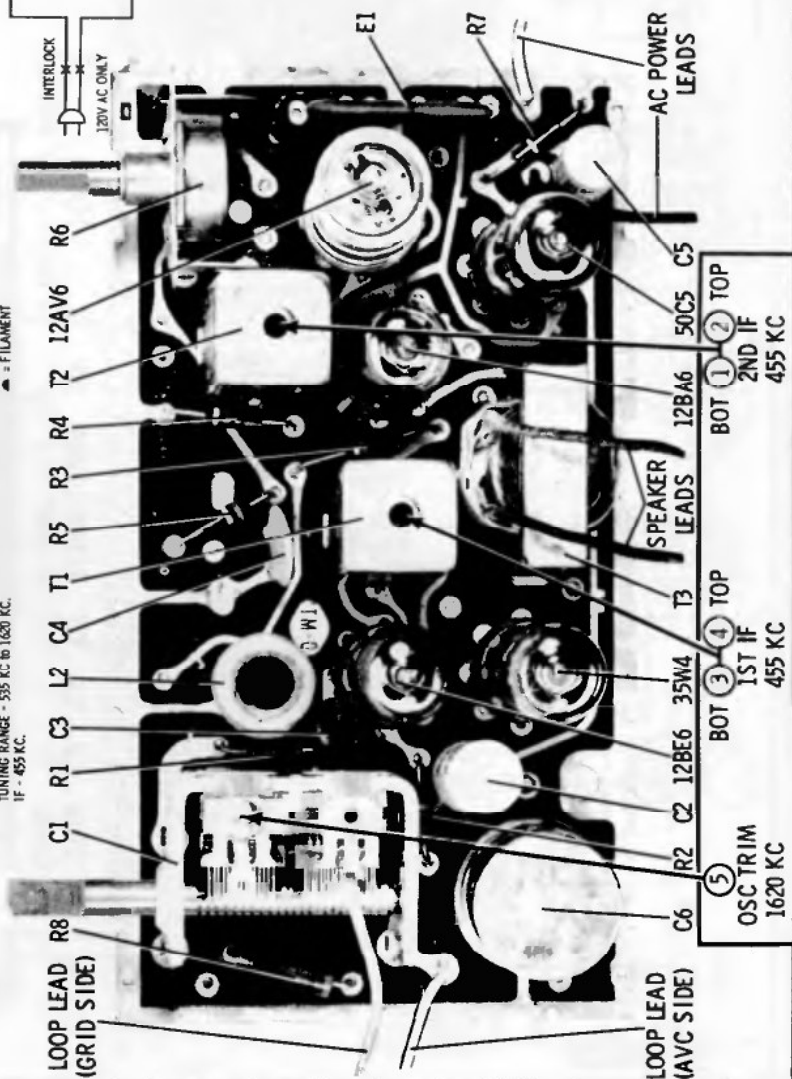

ALIGNMENT POINTS & PARTS LOCATIONS

| | |
|----------|---------|
| OSC TRIM | 1620 KC |
| BOT (5) | 1ST IF |
| TOP (4) | 455 KC |
| BOT (3) | 2ND IF |
| TOP (2) | 455 KC |

VOLUME R-19, MOST-OFTEN-NEEDED 1959 RADIO SERVICING INFORMATION

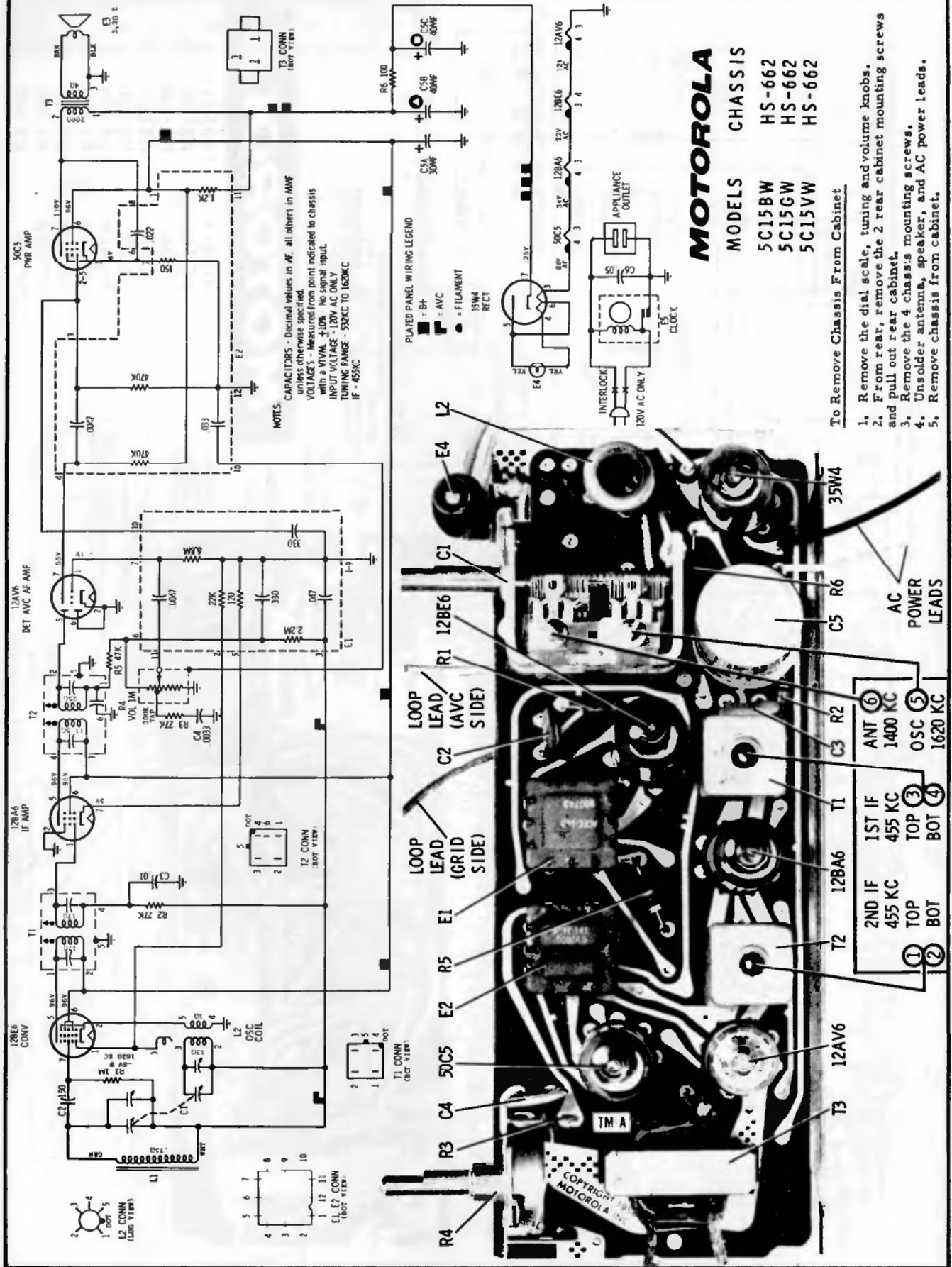

MOTOROLA
 MODELS CHASSIS
 5C15BW HS-662
 5C15GW HS-662
 5C15VW HS-662

To Remove Chassis From Cabinet

1. Remove the dial scale, tuning and volume knobs.
2. From rear, remove the 2 rear cabinet mounting screws and pull out rear cabinet.
3. Remove the 4 chassis mounting screws.
4. Unsolder antenna, speaker, and AC power leads.
5. Remove chassis from cabinet.

MOTOROLA MODELS CHASSIS
 2F12N HS-667
 2F12W HS-667

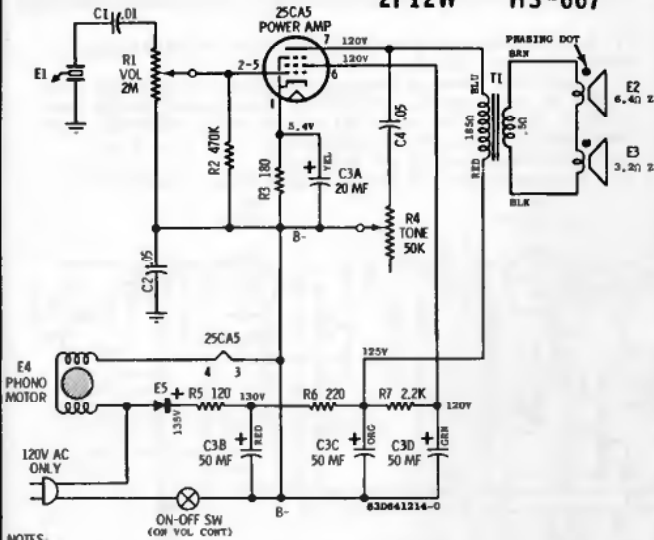

NOTES:
 CAPACITORS - Decimal values in MF, all others in MMF unless otherwise specified.
 VOLTAGES - Measured from point indicated to B- with a VTVM. \oplus = CHASSIS

DISASSEMBLY INSTRUCTIONS

To Remove Chassis from Cabinet

1. Pull off two knobs from front of cabinet.
2. Remove four (4) motorboard and three (3) baffle retainer screws.
3. Remove baffle.
4. Lift rear of motorboard slightly and slide out.
5. Remove two screws which hold chassis to motorboard and remove chassis.

To Remove Turntable

1. Remove "C" washer from spindle.
2. Remove turntable by pulling up - off of spindle.

MODELS CHASSIS
 2F11B HS-666
 2F11R HS-666

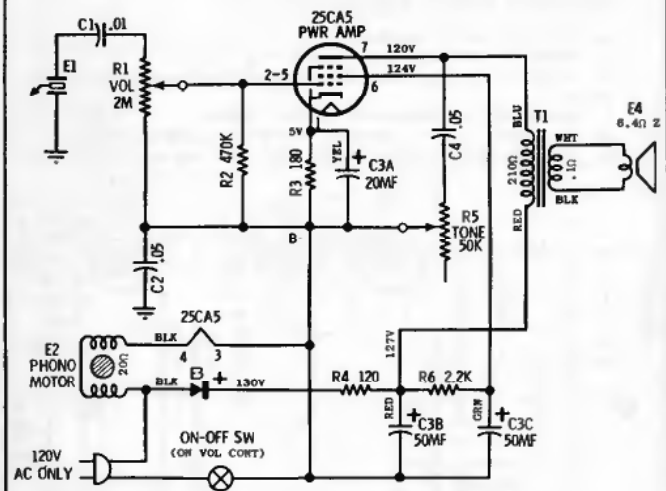

NOTES:
 CAPACITORS - Decimal values in MF, all others in MMF unless otherwise specified.
 VOLTAGES - Measured from point indicated to B- with a VTVM.
 CHASSIS - \oplus

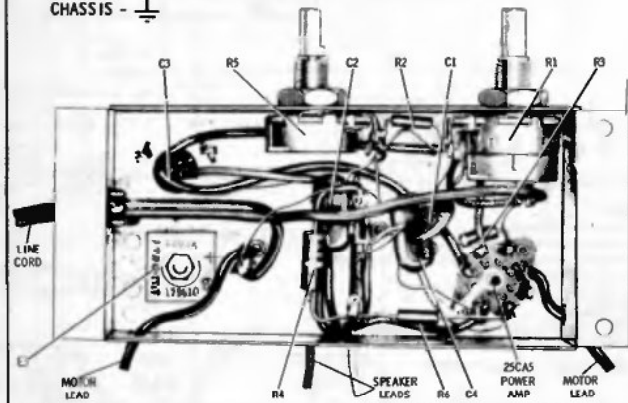

MOTOROLA

MODELS CHASSIS
 3F13B HS-668
 3F13W HS-668

NOTES:
 CAPACITORS - Decimal values in MF, all others in MMF unless otherwise specified.
 VOLTAGES - Measured from point indicated to B- with a VTVM. $\pm 10\%$. Line Voltage maintained at 120V AC.
 \oplus = B- \oplus = Chassis

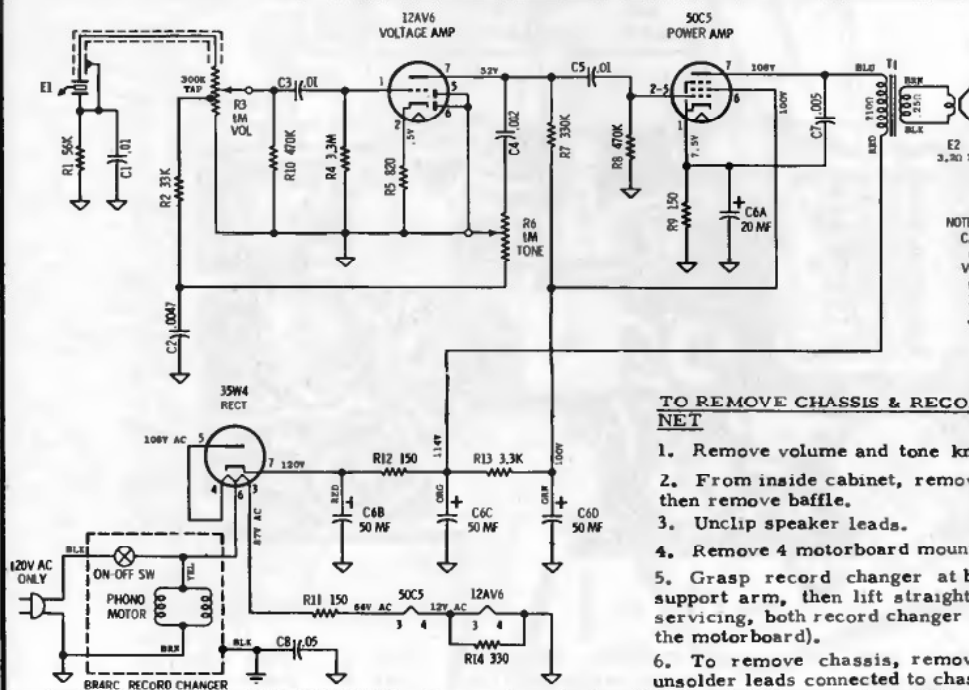

TO REMOVE CHASSIS & RECORD CHANGER FROM CABINET

1. Remove volume and tone knobs.
2. From inside cabinet, remove 3 baffle mounting screws, then remove baffle.
3. Unclip speaker leads.
4. Remove 4 motorboard mounting screws.
5. Grasp record changer at base of tone arm and record support arm, then lift straight out of cabinet (to facilitate servicing, both record changer and chassis are mounted on the motorboard).
6. To remove chassis, remove 4 chassis mounting nuts; unsolder leads connected to chassis if necessary.

MOTOROLA

MODELS CHASSIS
5R14N HS-670

To Remove Chassis From Cabinet

1. Pull off control knobs.
2. Remove 3 antenna panel mounting screws.
3. Remove antenna panel (disconnect line cord from interlock).
4. Disconnect antenna and speaker leads.
5. Remove 4 record changer board mounting screws.
6. Lift changer and mounting board up and out of the way.
7. Loosen 2 screws which hold interlock to cabinet; remove interlock from cabinet.
8. "Uncrimp" ends of chassis mounting brackets and melt solder at these points. CAUTION: Apply only enough heat to allow chassis to slide out of brackets; too much heat may damage the plated circuit board.
9. Slide chassis out of the brackets.
10. Disconnect record changer leads from chassis.

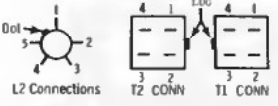
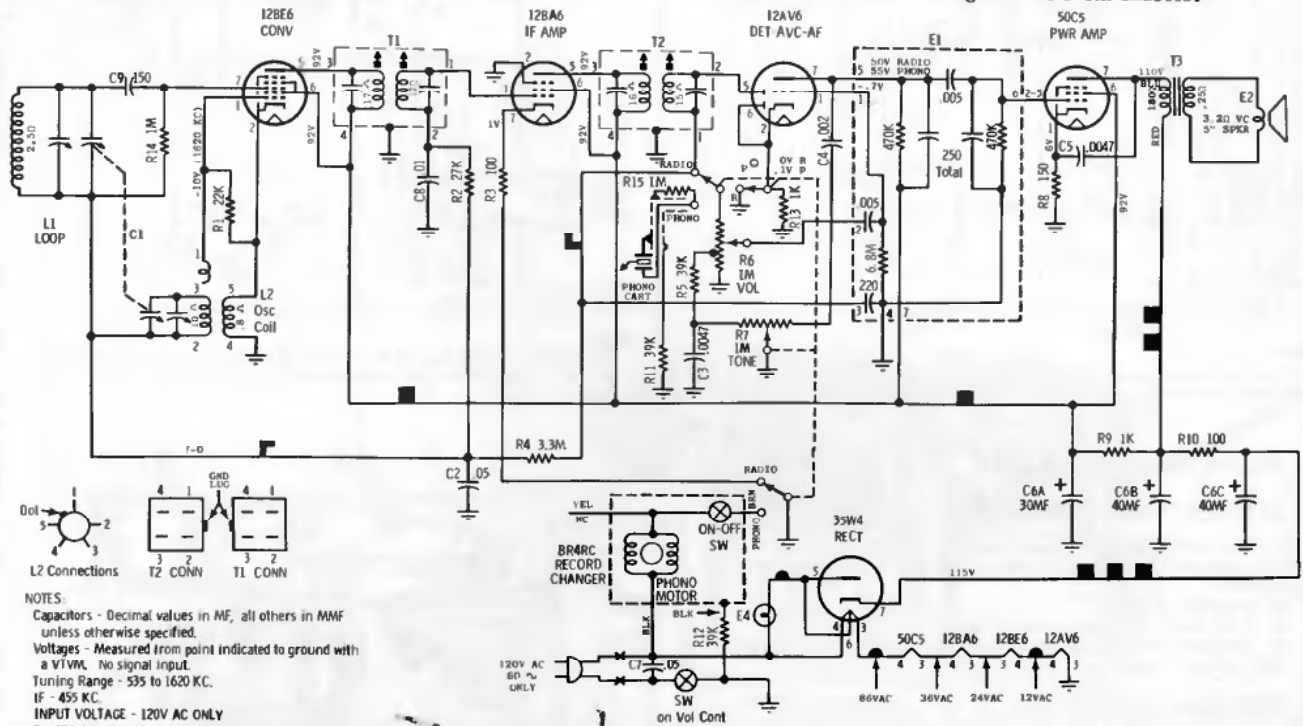

NOTES:
Capacitors - Decimal values in MF, all others in MMF unless otherwise specified.
Voltages - Measured from point indicated to ground with a VTVM. No signal input.
Tuning Range - 535 to 1620 KC.
IF - 455 KC.
INPUT VOLTAGE - 120V AC ONLY
PLATED PANEL WIRING LEGEND
■ - B+ ■ - AVC ■ - FILAMENT

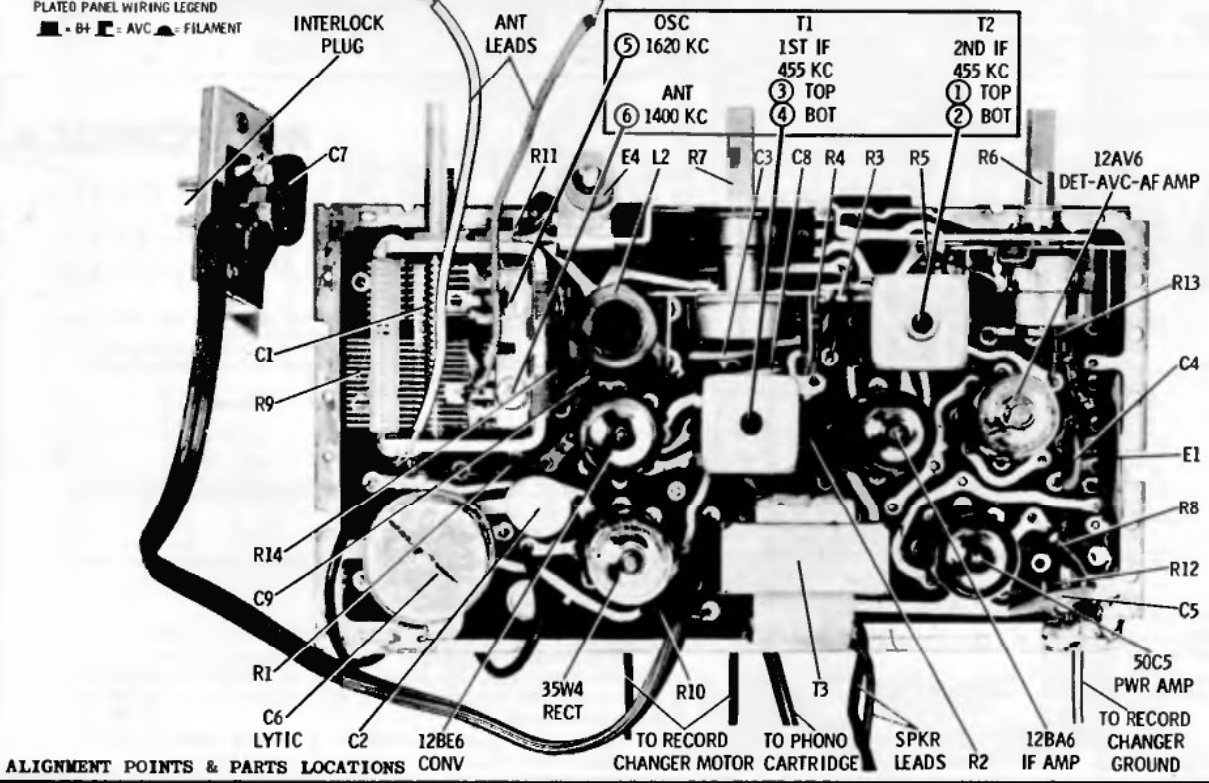

MOTOROLA

| MODELS | CHASSIS |
|--------|---------|
| 5K11B | HS-673 |
| 5K11M | HS-673 |
| 5K11MC | HS-673 |
| 5K11W | HS-673 |

NOTES:

CAPACITORS - Decimal values in MF, all others in MWF unless otherwise specified.
 VOLTAGES - Measured from point indicated to chassis with a VTVM, $\pm 10\%$. No signal in.
 S1 & S2 conn details viewed from indicated sides with arrow indicating clockwise rotation as viewed from front of control.
 S1 SHOWN IN PHONO POSITION IRIAAA
 S2 SHOWN IN EXT SPKR POSITION

⊥ = Chassis = Record changer base

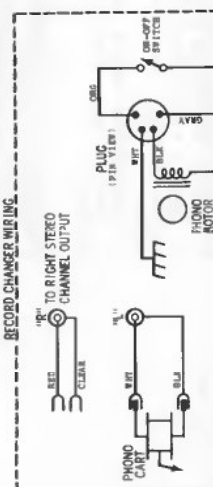
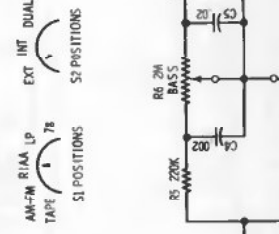
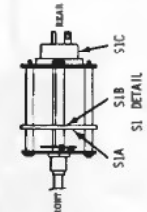
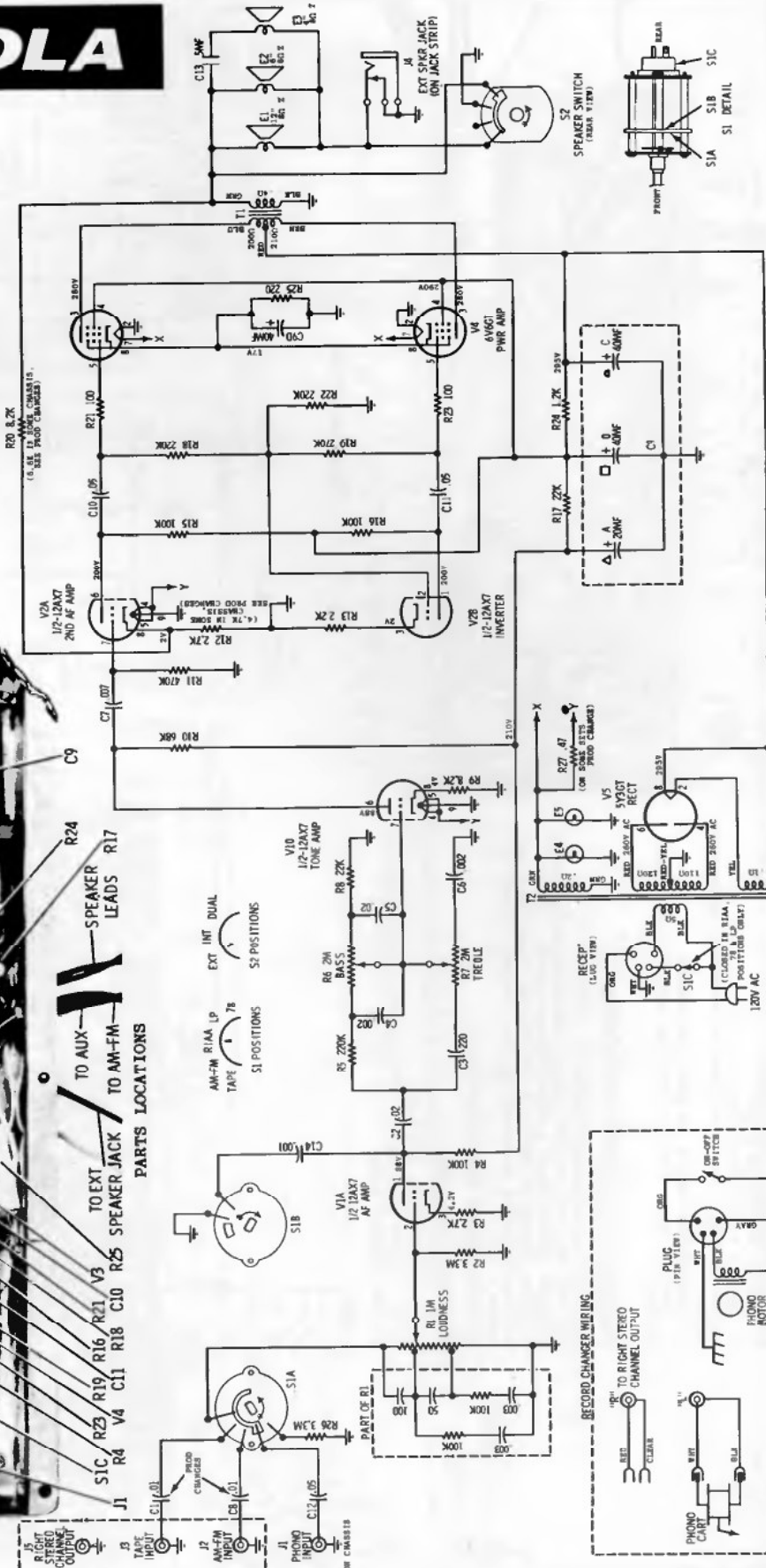
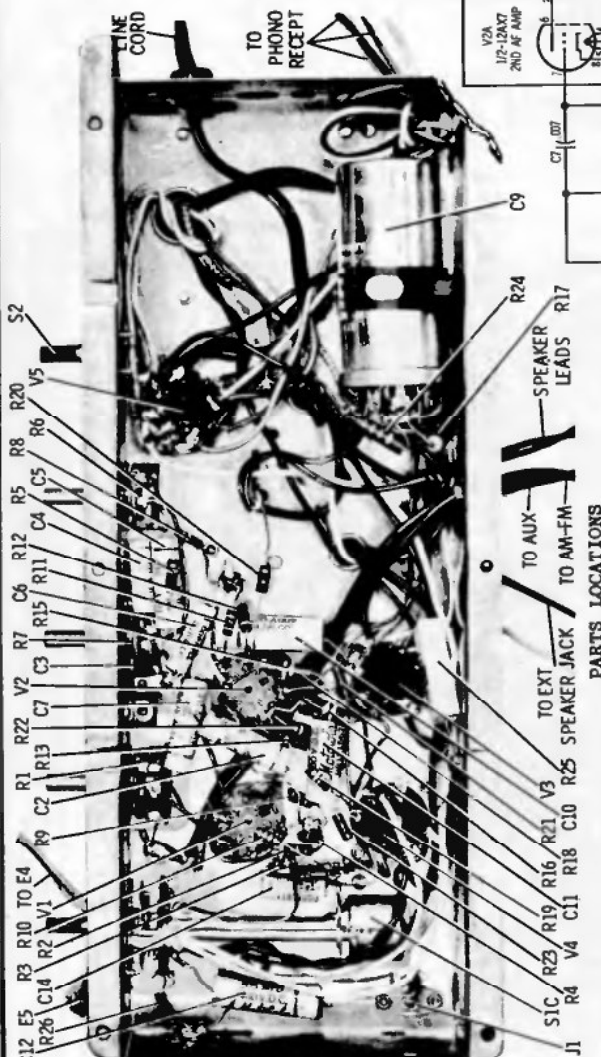

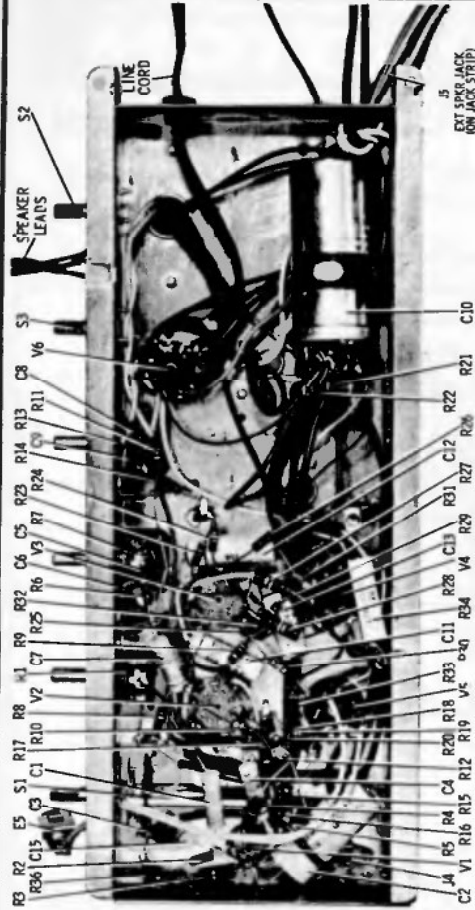

PARTS LOCATIONS

To Remove Chassis From Cabinet

1. Pull off the control knobs.
2. Remove cabinet back cover.
3. Disconnect leads from changer, auxiliary jacks and speakers.
4. Remove light shield and pilot light socket.
5. Remove three chassis mounting screws and remove chassis.

To Remove Record Changer From Cabinet

1. Remove back cover.
2. Disconnect all changer leads.
3. Turn the two record changer mounting screws fully clockwise (down flush against changer base).
4. From bottom of changer, turn the two Tinnerman nuts located at mounting screw ends so they are parallel with the screws.
5. Grasp changer by base and lift up.

To Replace Pilot Lights

1. To replace pilot light in record changer compartment, remove light shield, then bulb.
2. To remove pilot light on chassis, first remove chassis (see above), then bulb.

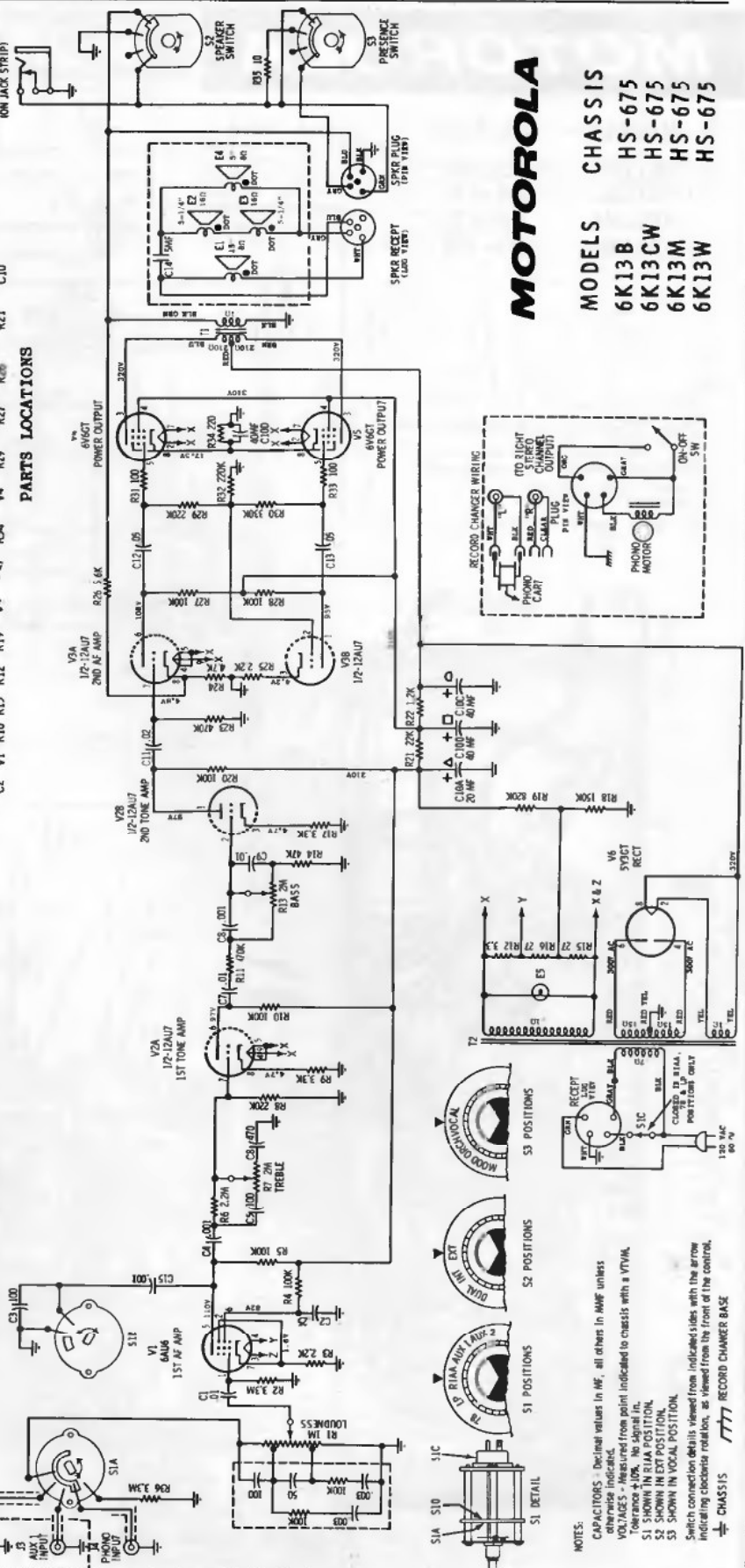

MOTOROLA

| MODELS | CHASSIS |
|--------|---------|
| 6K13B | HS-675 |
| 6K13CW | HS-675 |
| 6K13M | HS-675 |
| 6K13W | HS-675 |

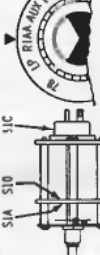
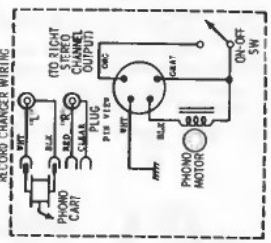

NOTES:
 CAPACITORS - Decaded values in MF, all others in MMF unless otherwise indicated.
 VOLTAGES - Measured from point indicated to chassis with a VTVM. Tolerance $\pm 10\%$, No signal in.
 S1 SHOWN IN R14A POSITION.
 S2 SHOWN IN EXT POSITION.
 S3 SHOWN IN VOCAL POSITION.
 Switch connection details viewed from indicated sides with the arrow indicating clockwise rotation, as viewed from the front of the control.
 CHASSIS

VOLUME R-19, MOST-OFTEN-NEEDED 1959 RADIO SERVICING INFORMATION

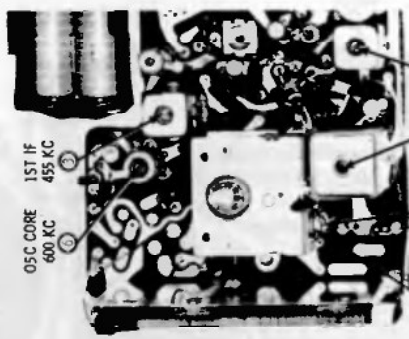
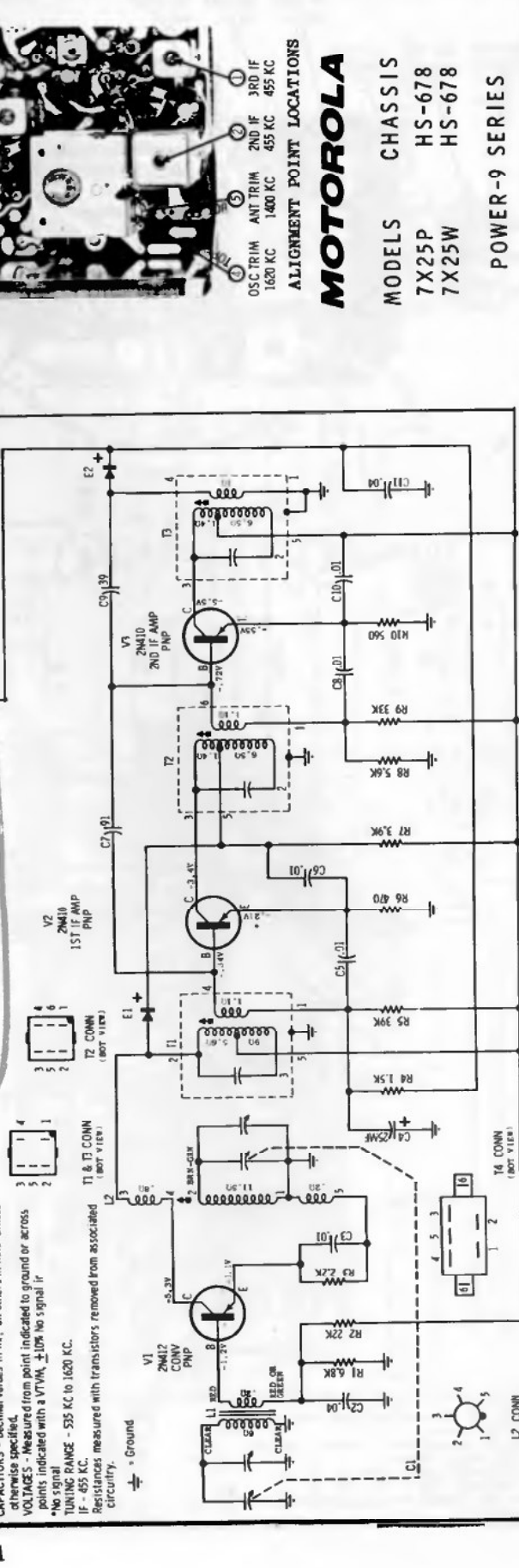
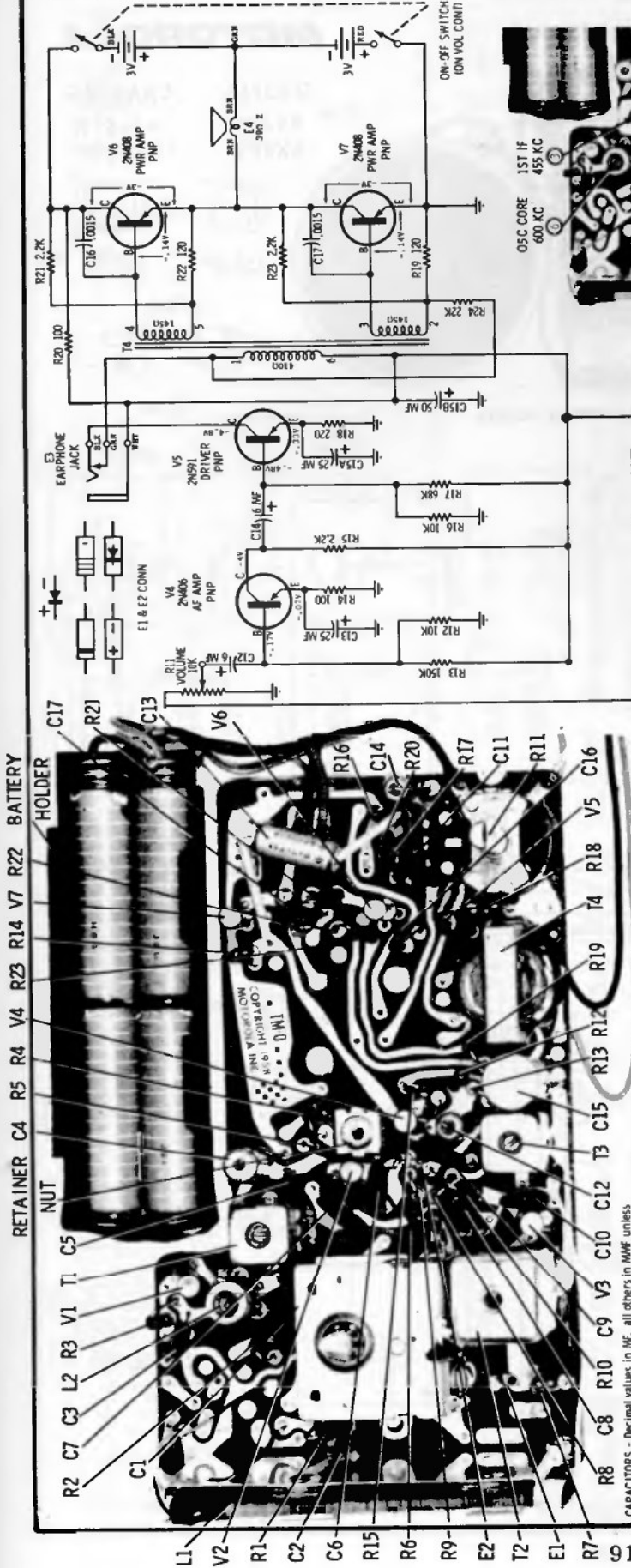

MOTOROLA

MODELS CHASSIS
 7X25P HS-678
 7X25W HS-678

ALIGNMENT POINT LOCATIONS

POWER-9 SERIES

CAPACITORS - Decimal values in MF, all others in MAF unless otherwise specified.
 VOLTAGES - Measured from point indicated to ground or across points indicated with a VTM, $\pm 10\%$ No signal. If "No signal" IF - 655 KC.
 TUNING RANGE - 535 KC to 1620 KC.
 Resistances measured with transistors removed from associated circuitry.

MOTOROLA

| MODELS | CHASSIS |
|--------|---------|
| 8X26E | HS-679 |
| 8X26S | HS-679 |

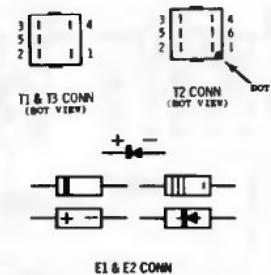
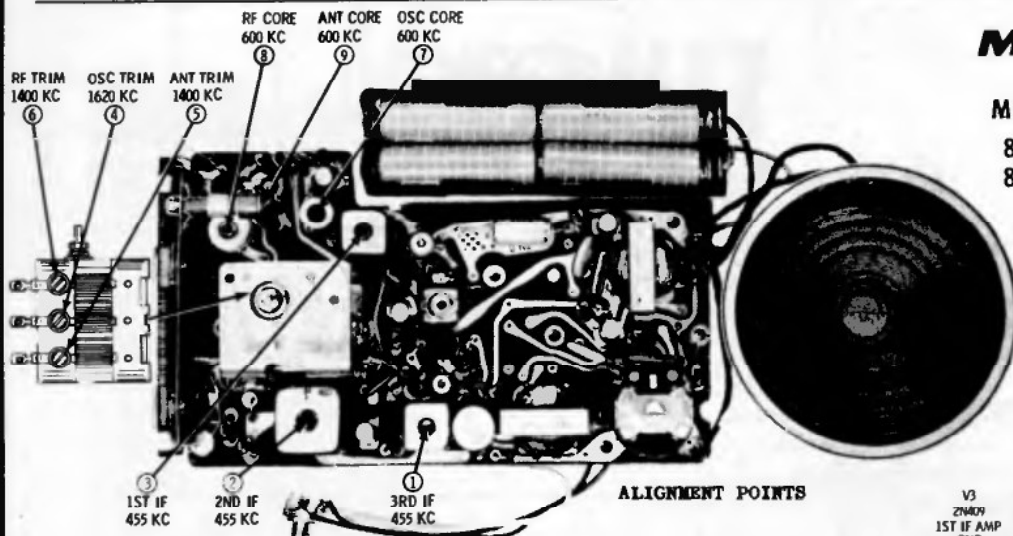

ALIGNMENT POINTS

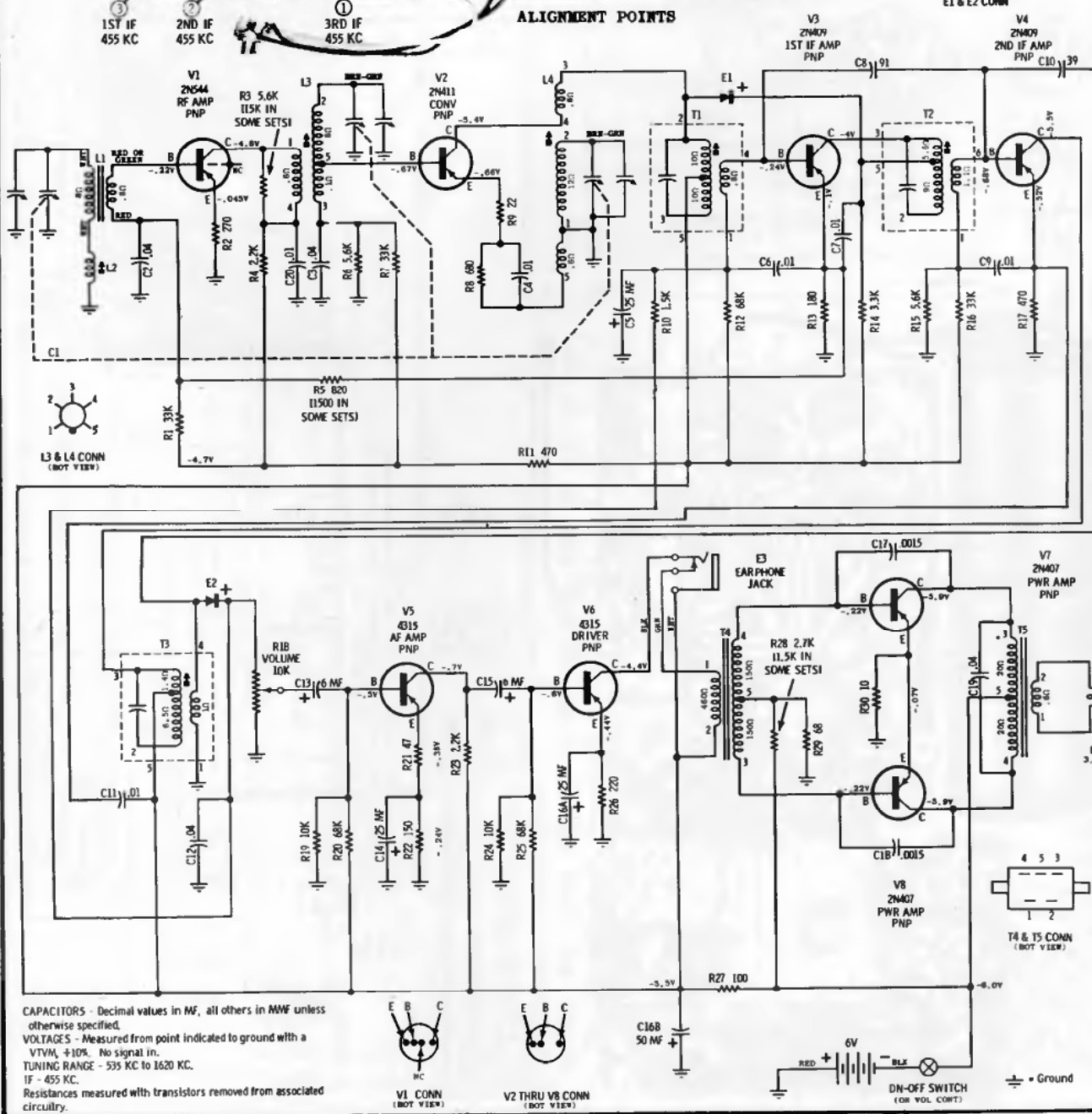

CAPACITORS - Decimal values in MF, all others in MMF unless otherwise specified.
 VOLTAGES - Measured from point indicated to ground with a VTVM, +10K. No signal in.
 TUNING RANGE - 535 KC to 1620 KC.
 IF - 455 KC.
 Resistances measured with transistors removed from associated circuitry.

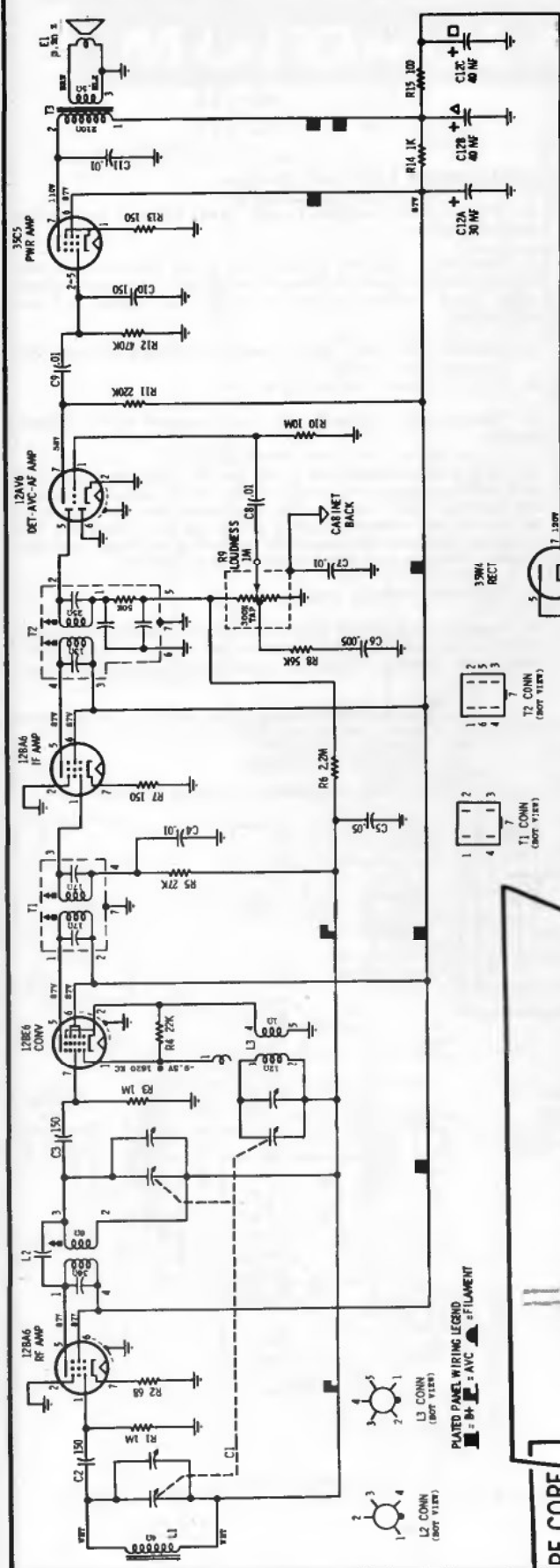

1. Remove two screws on bottom of cabinet; separate rear cabinet from front cabinet and unscrew (from inside rear cabinet) the lead lug which connects chassis to rear cabinet.
2. Remove the insert knob sections on the Loudness control and the Dial Scale. (The two control knobs are each composed of two sections.)
3. Remove Dial Scale knob and the screw (located behind knob) that mounts chassis to cabinet.
4. From front of cabinet, unscrew panelnut from Loudness control. It is not necessary to remove the Loudness Indicator knob in order to free the chassis.
5. From rear of cabinet, remove the two screws that mount the plated panel bracket to cabinet.
6. Unsolder speaker leads, antenna leads, and remove chassis from cabinet.

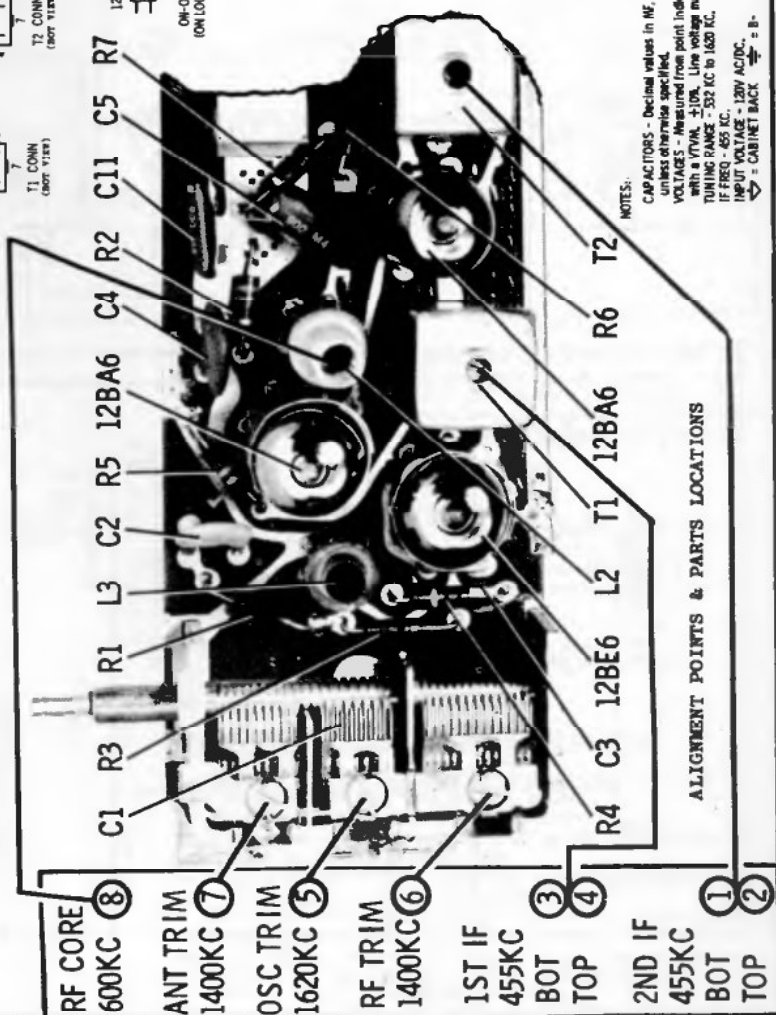

NOTES:
 CAPACITORS - Decimal values in MF, all others in MMF unless otherwise specified.
 VOLTAGES - Measured from point indicated to chassis with a VTVM, ±10%. Line voltage maintained at 120V.
 TUNING RANGE - 532 KC to 1650 KC.
 IF FREQ. 65 KC.
 IF FREQ. 139V AC/DC.
 ▽ = CABINET BACK
 ⊕ = B-

MOTOROLA
 MODELS CHASSIS
 6T15N HS-680
 6T15S HS-680

MOTOROLA

| MODELS | CHASSIS |
|--------|---------|
| 7X23E | HS-688 |
| 7X24S | HS-688 |
| 7X24W | HS-688 |

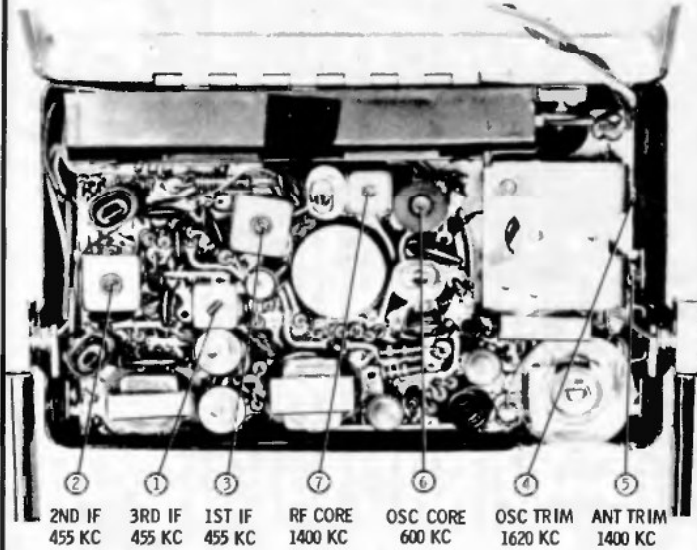

2ND IF 455 KC 3RD IF 455 KC 1ST IF 455 KC RF CORE 1400 KC OSC CORE 600 KC OSC TRIM 1620 KC ANT TRIM 1400 KC

ALIGNMENT POINT LOCATIONS

ESCUTCHEON & CHASSIS REMOVAL

1. From inside cabinet (below gang) remove escutcheon mounting screw.
2. Remove escutcheon by inserting small screwdriver into detent on edge of escutcheon and prying up. Work escutcheon free (use caution to prevent scratching cabinet and escutcheon.)
3. Remove dial and tuning knobs by pulling straight off.
4. Remove chassis mounting screw.
5. Turn handle perpendicular to component side of plated panel.
6. Grasp handle near one of its two mounting bushings and pull out from side of cabinet until the round portion of mounting bushing clears hole in side of cabinet, then lift this side of handle and chassis slightly out of cabinet. Perform the same procedure on the other mounting bushing, then lift handle, chassis and speaker plate out of cabinet.
7. Unscrew earphone jack.
8. Separate the plated chassis from the speaker mounting plate as follows: unsolder the wire that connects the gang to the plated chassis. Unsolder speaker lug, green lead from

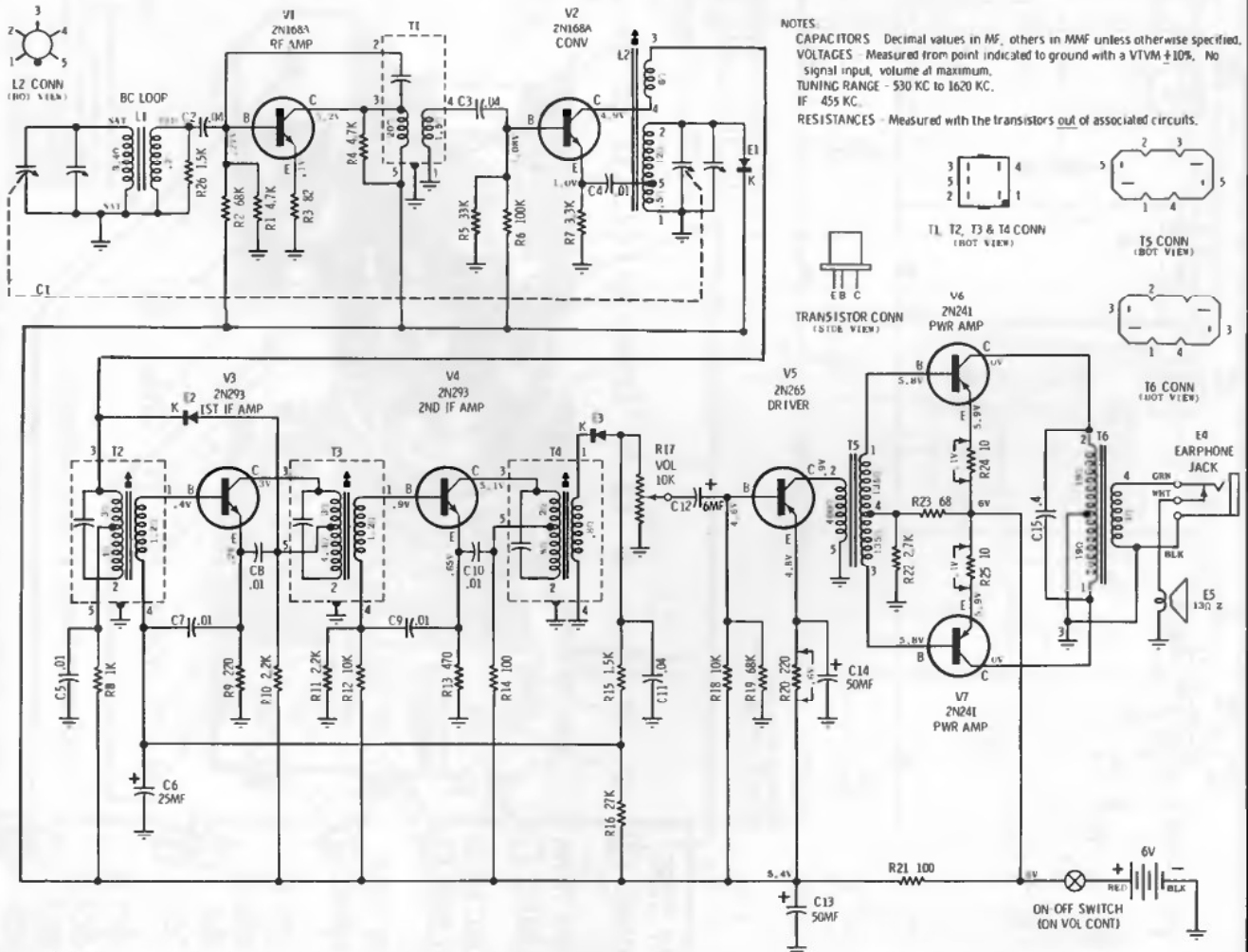

MOTOROLA

MODELS SF11B SF11N CHASSIS HS-703 HS-703

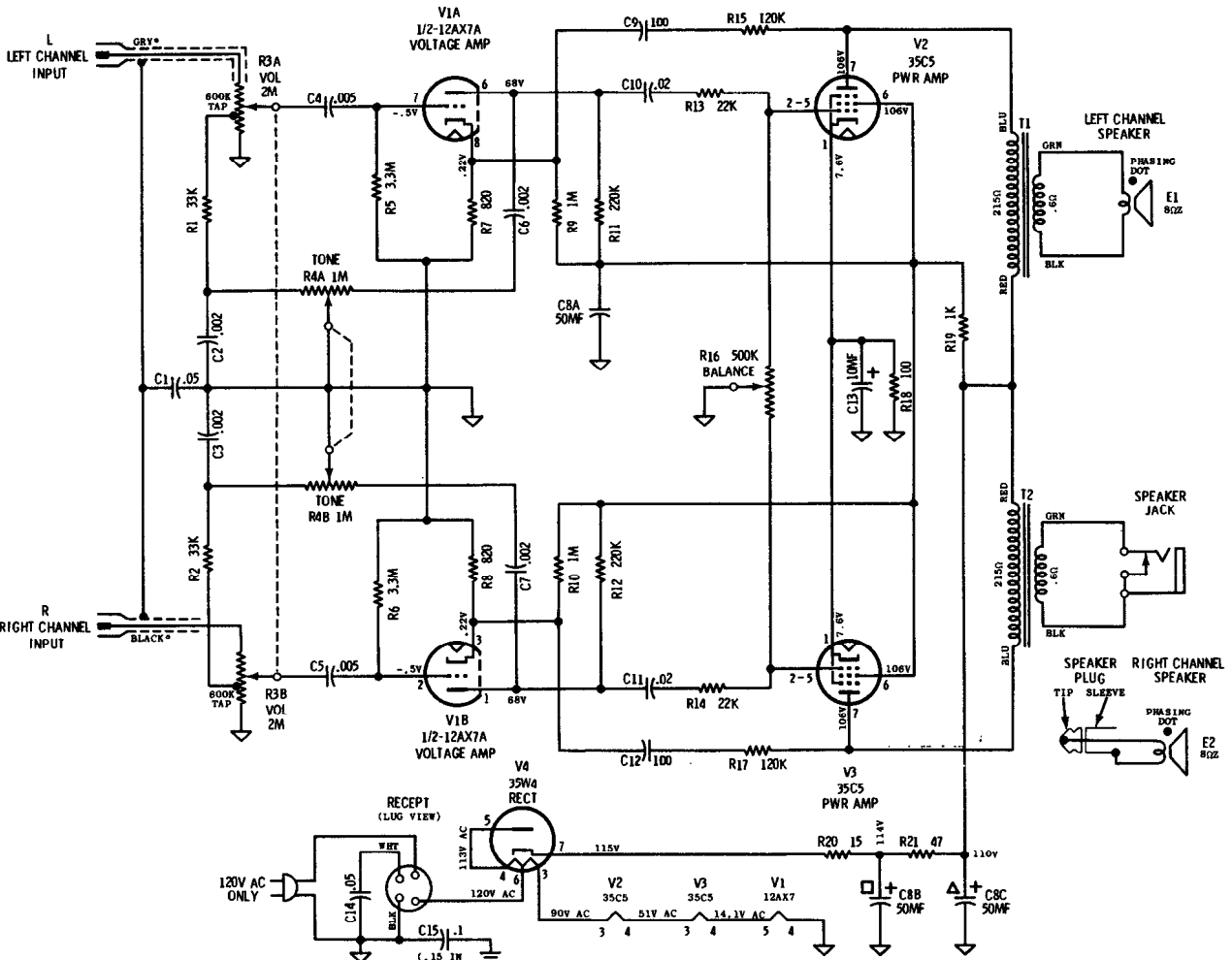

NOTES:
 CAPACITORS - Decimal values in MF, all others in MMF unless otherwise specified.
 VOLTAGES - Measured from point indicated to B- with a VTVM, ±10%. No signal in.
 ▽ - B- ⊕ - Chassis ▭ - Record changer frame
 *On some units, the phono input cable colors were reversed.

The chassis of this amplifier is isolated from the AC power line by a capacitor to eliminate the shock hazard when handling the chassis. However, as an additional precaution, when servicing this amplifier, an isolation transformer should be inserted between the power line and the chassis.

TO REMOVE CHASSIS FROM CABINET

1. Remove 3 control knobs.
2. Remove 3 baffle mounting screws and unscrew speaker jack mounted on baffle; then remove baffle.
3. Remove record changer mounting board screws.
4. Lift mounting board and record changer high enough to permit access to bottom of changer.
5. Unplug phono cables connected to record changer "R" and "L" jacks, also unplug phono power plug.
6. Remove 4 chassis mounting nuts.
7. Unsolder speaker leads.
8. Remove chassis from cabinet.

TO REMOVE RECORD CHANGER FROM CABINET

1. Remove 3 baffle mounting screws and unscrew speaker jack mounted on baffle; then remove baffle.
2. Remove record changer mounting board screws.
3. Lift mounting board and record changer high enough to permit access to bottom of changer.
4. Unplug phono cables connected to record changer "R" and "L" jacks, also unplug phono power plug.
5. Turn the two record changer mounting screws fully clockwise (down flush against changer base).
6. Place clips, located at ends of record changer mounting screws, so that they are parallel with the screws.
7. Remove record changer from cabinet.

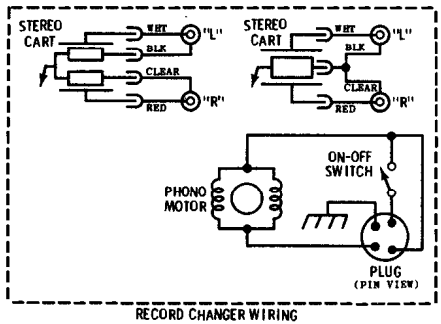

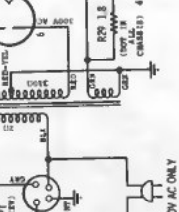
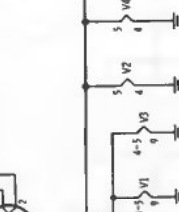
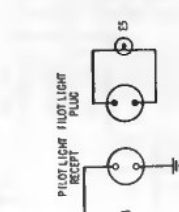
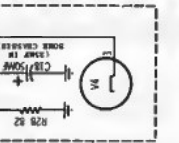
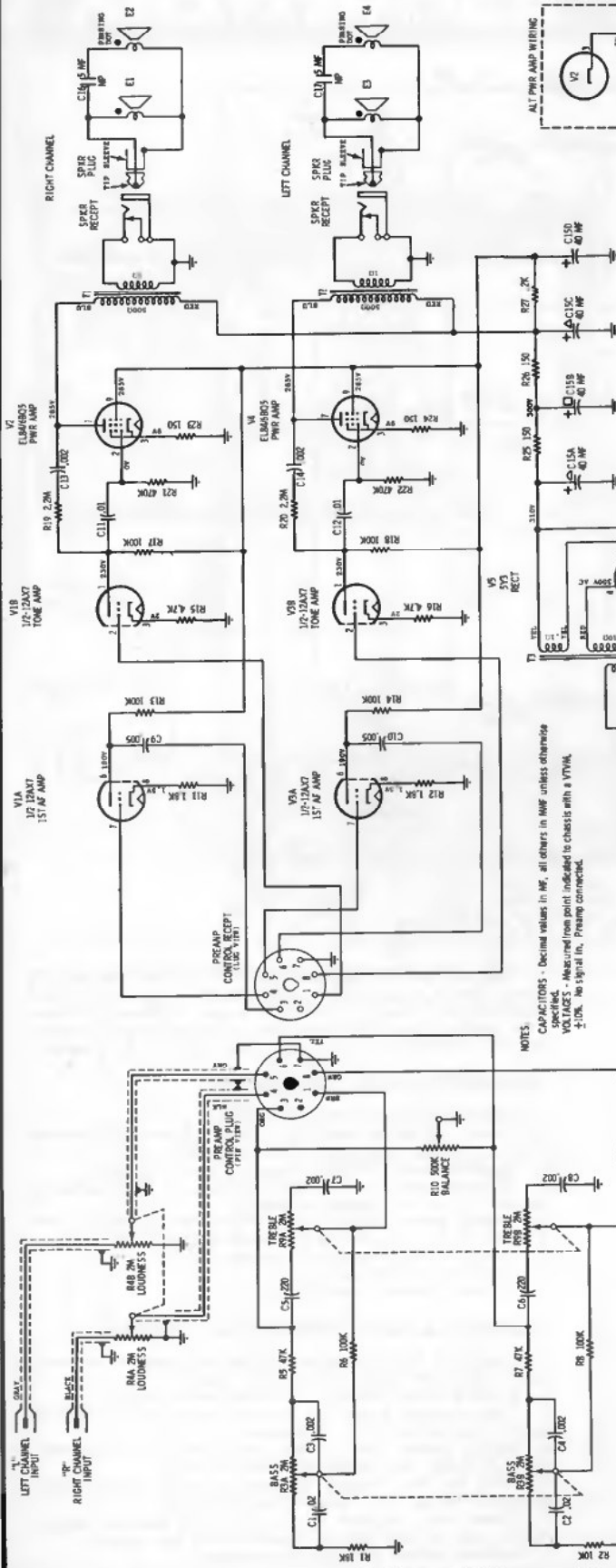

MOTOROLA

MODELS
SH12E
SH12N
SH12S

CHASSIS
HS-704
HS-704
HS-704

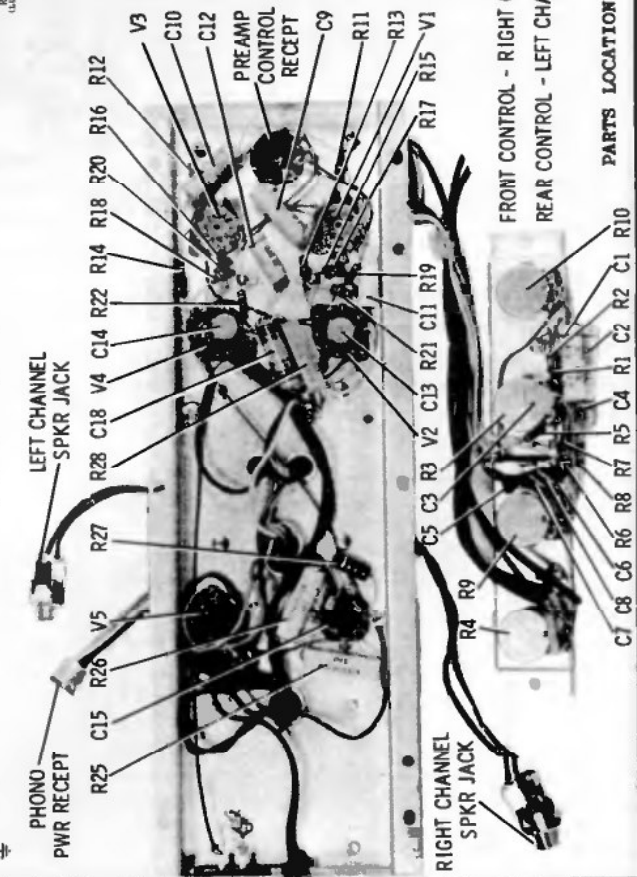
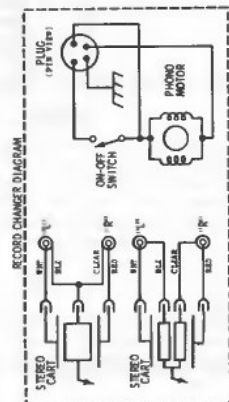

NOTES:
CAPACITORS - Decimal values in MF, all others in MUF unless otherwise specified.
VOLAGES - Measured from point indicated to chassis with a VTVM.
4-10% No signal in. Preamp connected.

MOTOROLA

MODELS CHASSIS
 SK21B, M HS-735
 SK23B, CW, M HS-735
 S21B, CW, M -

Models SK21 and SK23 are console stereophonic phonographs containing four-speed record changers with stereophonic cartridge and multiple speaker systems. These models differ from each other in type of record changer used and cabinet design. Model S21 is the right channel speaker system used with SK21 and SK23 to complete the stereophonic system.

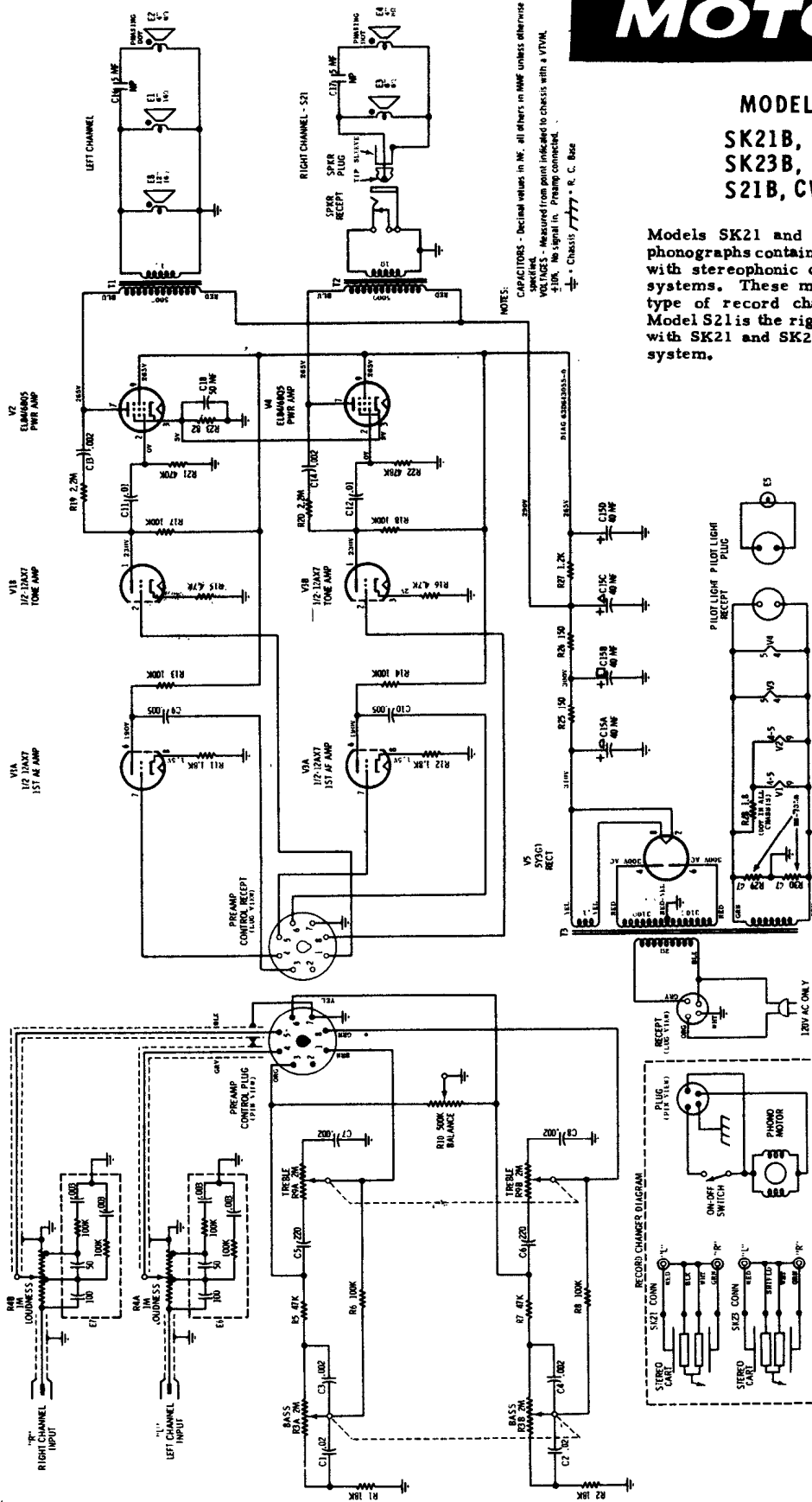

To Remove Record Changer from Cabinet (SK23 Series)

1. Remove back cover.
2. Disconnect all changer leads.
3. Turn two record changer mounting screws fully clockwise.
4. From bottom of changer, turn the two mounting clips located at mounting screw ends so they are parallel with the screws.
5. Grasp changer by base and lift up.

To Replace Pilot Light (All Models)

1. Remove cabinet rear cover.
2. From inside cabinet, unclip pilot light socket from mounting bracket.
3. Remove pilot light.

DISASSEMBLY INSTRUCTIONS

To Remove Chassis from Cabinet (All Models)

1. Pull off control knobs.
2. Remove cabinet back cover.
3. Disconnect all leads from changer and speakers.
4. Unplug pilot light at chassis.
5. Unplug control plug at chassis.
6. Remove nut from output jack and remove jack from mounting bracket.
7. Remove chassis mounting screw and slide chassis out rear of cabinet.
8. Remove 2 nuts from control unit mounting screws.
9. Remove control unit.

Olympic MODEL 688

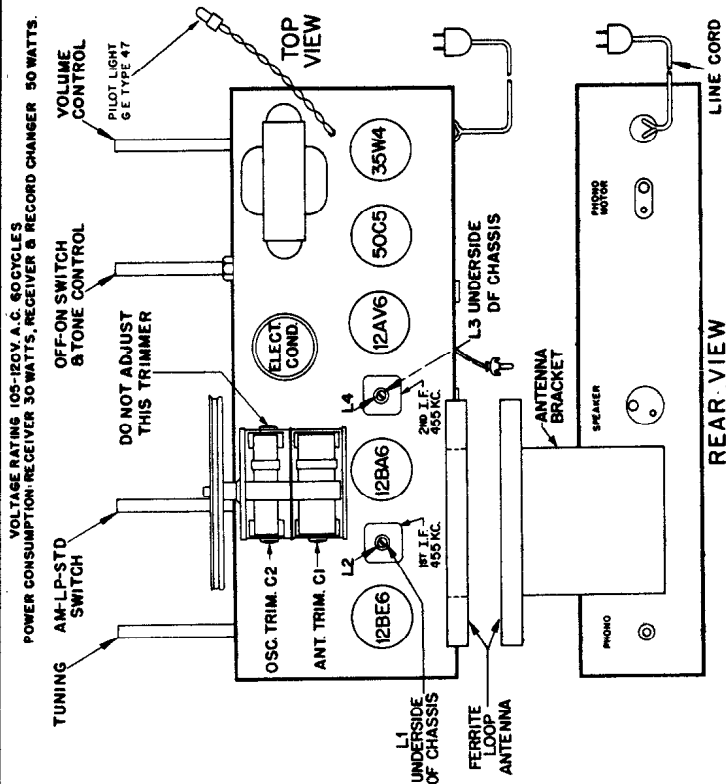

ALIGNMENT:

Equipment required: Modulated RF signal generator; output meter; insulated screw-driver; two .1 mfd 400 volt condensers.

To insure proper alignment, a radiated signal will be required during part of the alignment procedure. To radiate a signal, connect a loop of about 6 inches in diameter (one turn of #14 or #12 wire) across the output of the signal generator, and place this loop perpendicular to the Ferrite stick antenna of the receiver to be aligned, at a distance of about 10 or 12 inches.

Connect the output meter and signal generator as follows:
 Output meter: Connect across the speaker voice coil and turn the volume control to maximum (extreme clockwise position).

| ALIGNMENT PROCEDURE CHART | | ADJUST THE FOLLOWING FOR MAXIMUM OUTPUT. (KEEP SIGNAL FROM SIGNAL GENERATOR AS LOW AS POSSIBLE.) | |
|---------------------------|--|--|---|
| STEP | CONNECT HIGH SIDE OF SET SIGNAL GENERATOR TO - | TURN RECEIVER DIAL TO - | |
| 1 | ANTENNA SECTION TUNING CONDENSER IN SERIES WITH .1 MFD COND. | 495 KC. | FULL CLOCKWISE POSITION (CONDENSER PLATES FULLY OPEN) (1st. AND 2nd. I.F. TRANSFORMERS) |
| 2 | USE RADIATED SIGNAL | 1500 KC. | 1500 KC. (150 ON DIAL) |
| 3 | | 1500 KC | MAXIMUM SIGNAL (APPROX. 150 ON DIAL) |
| 4 | | | C 2 (OSCILLATOR) C 1 (ANTENNA) |
| | | | REPEAT STEPS 2 AND 3 |

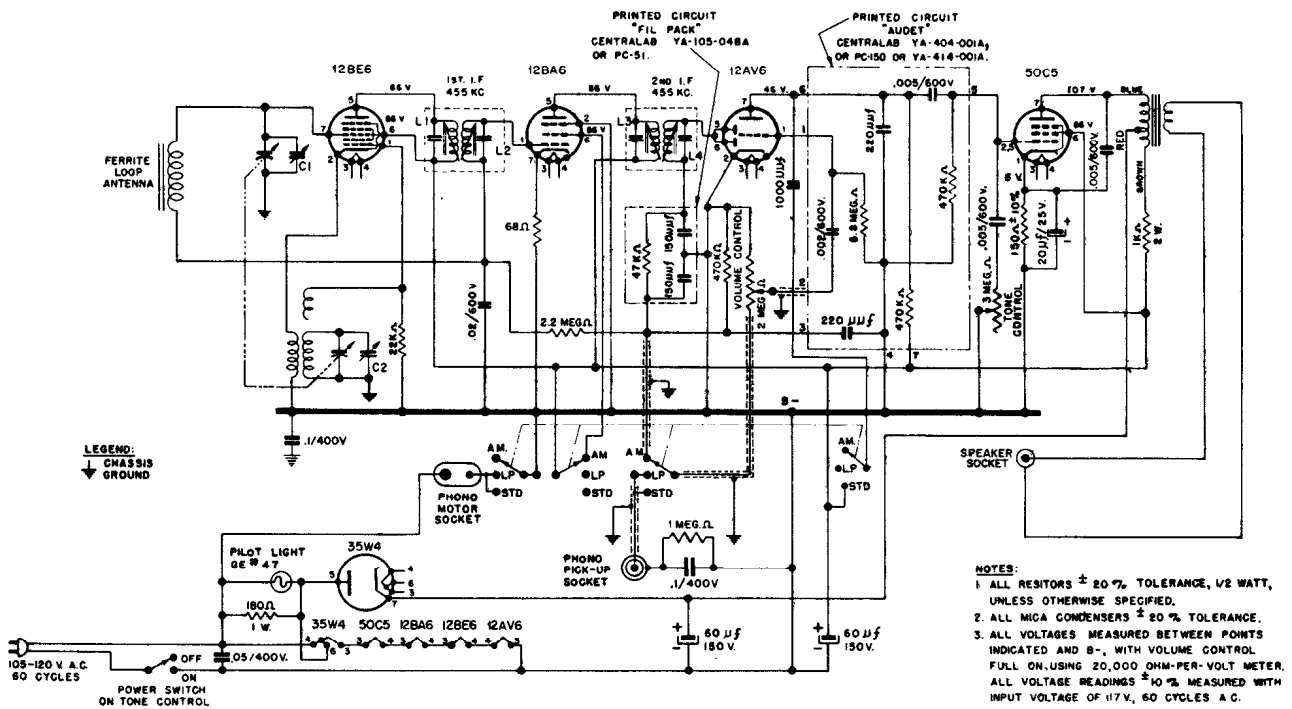

PACKARD BELL

TABLE MODEL RADIO 5R5

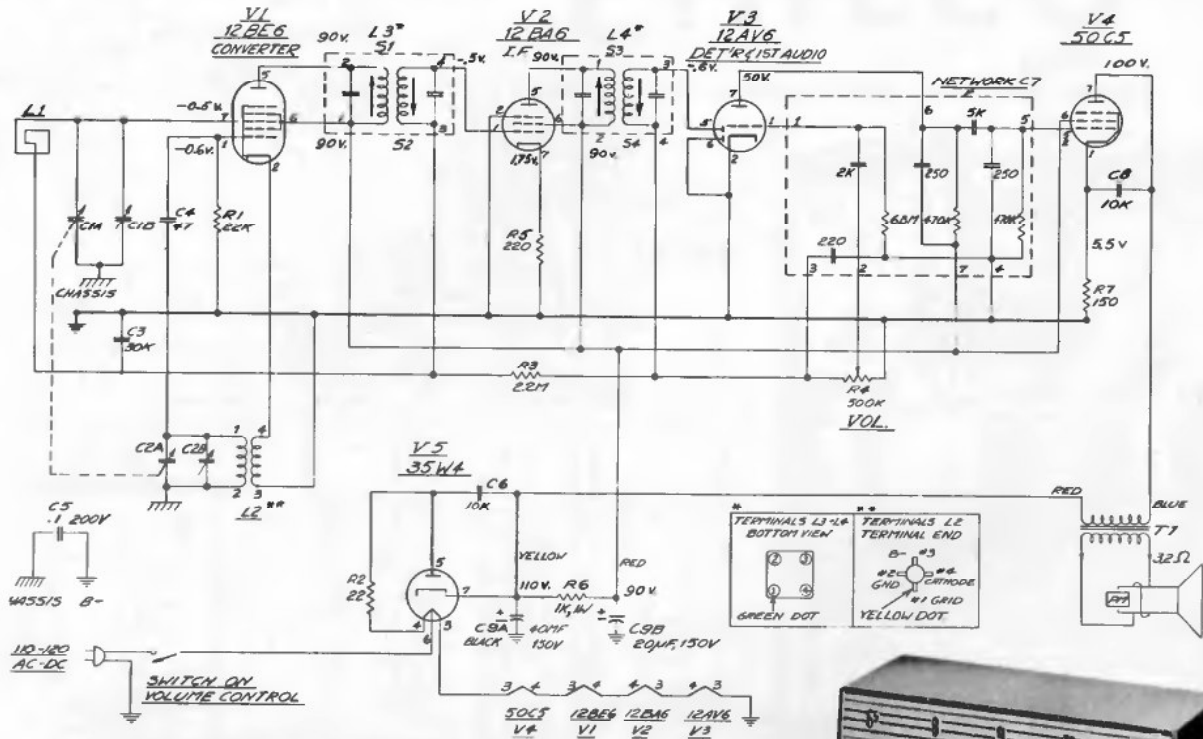

DC RESISTANCE MEASUREMENTS:

- 1st I-F Coil:**
 - Primary, 19 ohms
 - Secondary, 19 ohms
- 2nd I-F Coil:**
 - Primary, 19 ohms
 - Secondary, 19 ohms
- Oscillator Coil:**
 - Primary, 1 ohm
 - Secondary, 10 ohms

Socket voltages measured as follows:

1. Line voltage, 117 volts AC.
2. Volume control at maximum.
3. VTVM between socket terminal and B minus bus.
4. Only DC voltages measured. Allow 10% tolerance.

ALIGNMENT PROCEDURE:

The alignment of the set is accomplished by following the steps in the chart below. Connect output meter to speaker voice coil. Use isolation transformer, if available, for shock protection.

Each adjustment should be made using a minimum input signal. Connect oscillator through a .01 mfd capacitor in step one; loose-couple oscillator lead in steps two and three.

| Step | Connect Test Oscillator To | Test Oscillator Frequency | Radio Dial Setting | Adjust |
|------|----------------------------|---------------------------|---------------------|-------------------------------|
| 1. | Pin 1, V-1 (12BE6) | 455 Kc. | 540 Kc. | S-1, S-2, S-3, & S-4 for MAX. |
| 2. | Loose-couple to antenna | 1620 Kc. | 1620 Kc. | C-2B for MAX. |
| 3. | ditto | 1500 Kc. | Tune to Osc. Signal | C-1B for Max. |

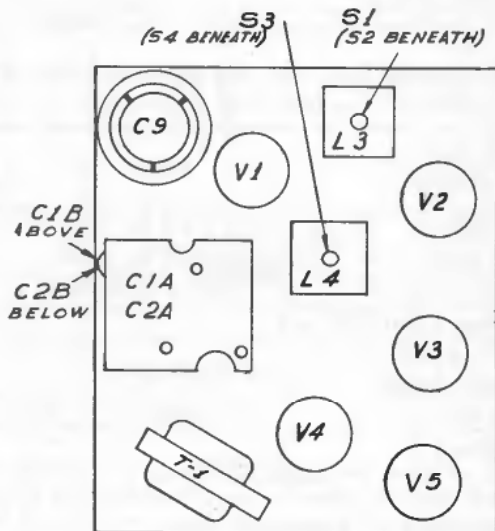

PACKARD BELL MODEL 6RT2 PERSONAL TRANSISTOR RADIO

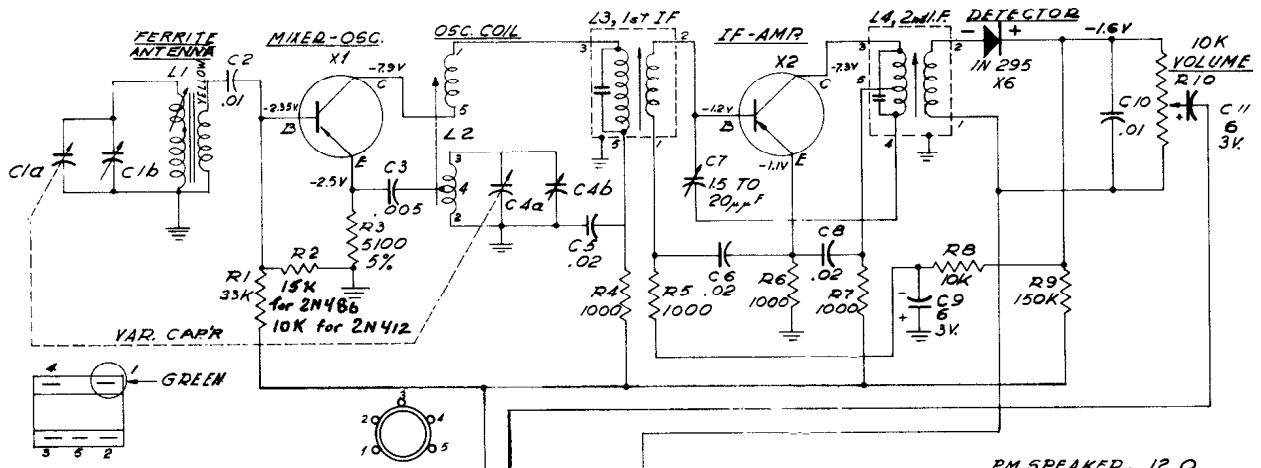

BOTTOM VIEW OF I-F AND OSCILLATOR COIL TERMINALS

- NOTE:**
 1. ALL RESISTORS $\frac{1}{2}$ WATT $\pm 10\%$ UNLESS OTHERWISE NOTED
 2. K = 1000 OHMS
 3. ALL CAPACITORS IN MFD UNLESS OTHERWISE NOTED
 4. D.C. WORKING VOLTAGE IS 25V. UNLESS OTHERWISE NOTED
 5. D.C. VOLTAGES MEASURED WITH KTY.M. TO COMMON GROUND (POSITIVE) - NO SIGNAL - VOL. CONTR. AT MAX.

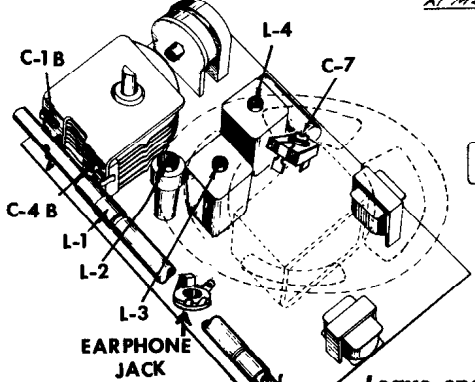

ALIGNMENT: Leave speaker in place; adjust L-2, L-3, & L-4 from rear.

Step 1. Preset I-F amplifier neutralizer capacitor C-7 by turning completely clockwise (maximum capacity) then back one eighth of a turn (45 degrees). See note after step seven.

| ITEM | TRANSISTORS | RAYTHEON | R.C.A. |
|------|----------------|----------|--------|
| X1 | MIXER-OSC. | 2N486 | 2N412 |
| X2 | I.F. AMR | 2N485 | 2N410 |
| X3 | AUDIO AMR | 2N363 | 2N406 |
| X4,5 | AUDIO OUT.* | 2N632 | 2N408 |
| X6 | DETECTOR DIODE | IN295 | |

* MATCHED PAIR OR SAME GAIN GROUP NO.

| Step | Connect Test Oscillator To | Test Oscillator Frequency | Radio Dial Setting | Adjust |
|------|--|---------------------------|--------------------------|-----------------------|
| 2. | Variable, antenna section | 455 kc | 535 kc | L-3 & L-4 for MAX |
| 3. | Couple to antenna | 600 kc | 600 kc | L-2 (osc) for MAX |
| 4. | Couple to antenna | 1620 kc | 1620 kc | C-4B for MAX |
| 5. | Repeat steps two and three and check calibration at low end of dial (535 kc) | | | |
| 6. | Couple to antenna | 1500 kc | Tune to test osc. signal | C-1B for MAX |
| 7. | Couple to antenna | 600 kc | 600 kc | L-1 (antenna) for MAX |

NOTE: Optimum setting of neutralizing capacitor C-7 depends upon parameters X-2 and L-4. If, after alignment, regeneration occurs on stations near the high end of the dial, capacity of C-7 should be decreased (ccw). Too low a value, however, will result in loss of

sensitivity. If it has been necessary to change the setting of C-7 more than 45 degrees after completing the alignment, then the I-F adjustment (step two) should be repeated.

PHILCO RADIO MODEL T-3 - CODES 132, 134, 136 & 138

| | | |
|------|------------------|------------------|
| 138 | T-0041 | 120K Ω |
| 136 | T-0040 | 220 K |
| 134 | T-0039 | 470 K |
| 132 | T-0038 | 1M |
| CODE | AUDIO TRANSISTOR | BASE RESISTOR RB |

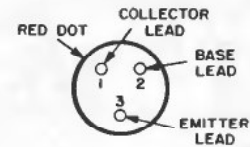

AUDIO TRANSISTOR - CODE VARIATIONS

The only differences between the four codes are the audio transistor type and the value of the audio base resistor. These value differences are indicated in the chart above.

PANEL-WIRE TERMINAL IDENTIFICATION

- L1 Orange lead from r-f tuning, C2, to T1 lug 4.
- L2 Black lead from r-f tuning, C2, to T1 lug 3 and red jumper to terminal 6.
- L3 Orange lead from ant. tuning, C1, and plain lead from bottom of ant. pri. (LA1) to panel ground.
- L4 Red lead from bottom of ant. sec. (LA1) to junction of R1, C4 and C5.
- L5 Red lead from top of ant. sec. (LA1) to 1st r-f base.
- L6 Red jumper from terminal 2, black jumper to terminal 11 and junction of C6 and R2.
- L7 Yellow lead to arm of volume control (R5).
- L8 Earphone lead to audio collector.
- L9 Black lead from battery, -1.3 volts.
- L10 Red lead from switch S1 lug 7, +1.3 volts.
- L11 Black jumper from terminal 6 to C10, the lufid audio coupling.
- L12 Orange lead to top of volume control, R5 lug. 1.
- L13 Black lead from switch, S1, lug 6 to panel ground.

SHIELDING

To suppress possible regeneration, the leads of T1 are shielded by wrapping a small piece of aluminum tape around the can so as to cover the cut-outs. When replacing be careful not to cause shorts.

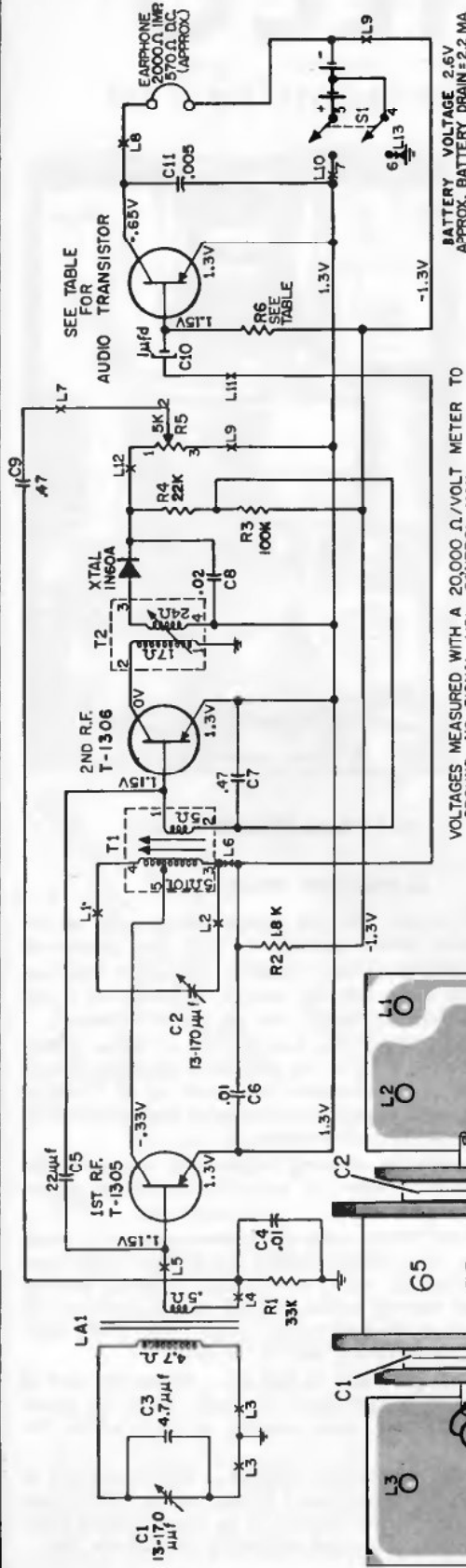
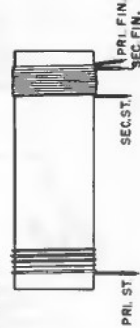

VOLTAGES MEASURED WITH A 20,000 Ω/VOLT METER TO GROUND, NO SIGNAL, VOL. CONTROL MAX.
RESISTANCES MEASURED WITH COILS IN CIRCUIT.

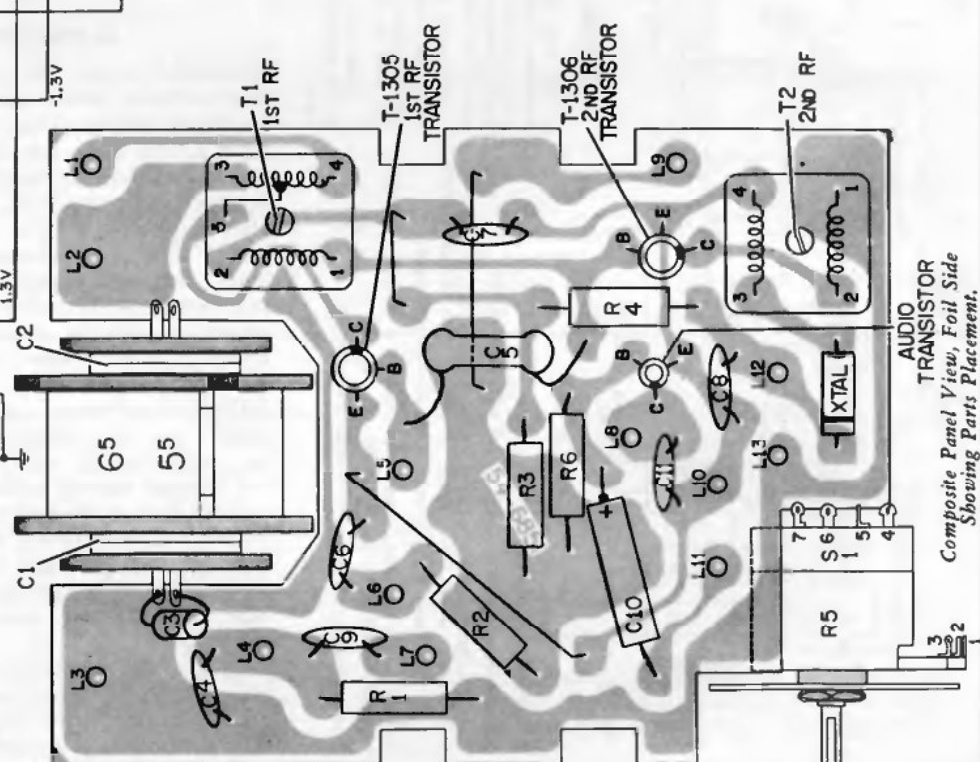

PHILCO

MODELS T-4 and T-4J - CODE 124

ALIGNMENT CHART

| STEP | SIGNAL GENERATOR | | RADIO | | ADJUST |
|------|---|--------------|---------------------------|---|-------------------------------------|
| | CONNECTION TO RADIO | DIAL SETTING | DIAL SETTING | SPECIAL INSTRUCTIONS | |
| 1 | Panel must be removed from cabinet. Connect signal generator through a .1 uf condenser to antenna section of gang. Use the least generator signal necessary to give an output indication. | 455 KC | Tuning gang fully open. | Adjust for maximum output in order given. | Z3—3rd IF Z2—2nd IF Z1—1st IF |
| 2 | Use radiating loop (See note 1 below). | 1620 KC | 1620 KC (gang fully open) | Pre-set C2A (Ant.) 1/2 turn from tight. Adjust for maximum output. | C1B—osc. trimmer |
| 3 | Same as step 2. | 1400 KC | 1400 KC | Adjust for maximum output. | C1A—ant. trimmer |
| 4 | Same as step 2. Panel MUST be re-mounted in cabinet. | 600 KC | 600 KC | Adjust for maximum output. Rock tuning gang while making this adjustment. | T1—osc. core |
| 5 | Repeat steps 2, 3 and 4 until no further improvement is obtained. Always stop on step 2. | | | | |

NOTE 1. Use a 6-to-8 turn, 6-inch diameter loop made up of insulated wire. Connect to generator terminals, and place about one foot from radio loop.

SCHEMATIC NOTES

Due to 2nd IF transistor variations the values of resistors R6 and R7 must be selected, within limits, for optimum performance.

When transistor R186 is defective, kit number 324-8003 must be ordered. This kit contains a R186 transistor and two resistors (R6 and R7) properly matched. All three components must be replaced.

The stage may be checked as follows:

The value of R6 is selected to allow the 2nd IF transistor collector to draw 2 milliamps. This is checked by measuring the voltage across R11, the 560 ohm collector return resistor. This voltage should be 1.12 volts, with a tolerance of approximately $\pm .12$ volts. The value of R6 falls within the limits of 27K to 390K.

All resistors are 1/2 watt, 10%, carbon.

Coil resistances read with coil in circuit.

Voice coil impedance = 14 ohms.

Voltages measured to ground with a 20,000 ohms/volt meter under no signal condition.

Emitter to base voltages were measured with positive lead to emitter, except for the 1st IF which is an NPN type and measured with the positive lead to the base.

Run #51 — to improve low end sensitivity. The value of R1 was changed to 15,000 ohms, part number 66-3158340. Some few sets may have a 10,000 ohm resistor for R1.

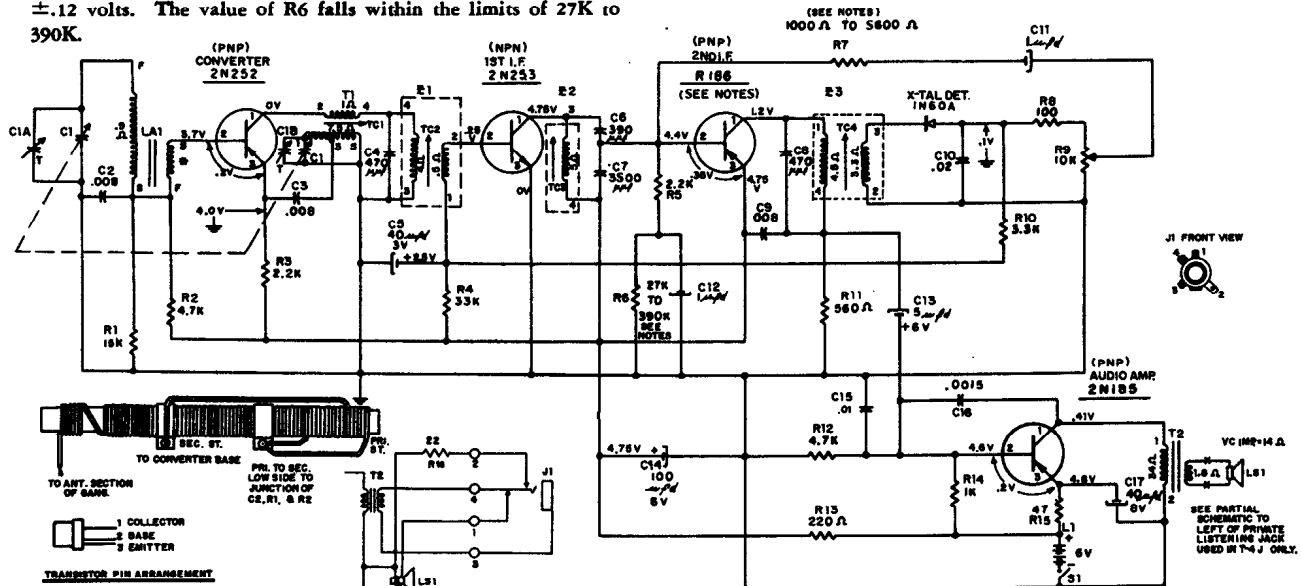

PHILCO

PHILCO TRANSISTOR RADIO MODEL T-5 - CODE 124

Schematic Diagram of Model T-5 - Code 124

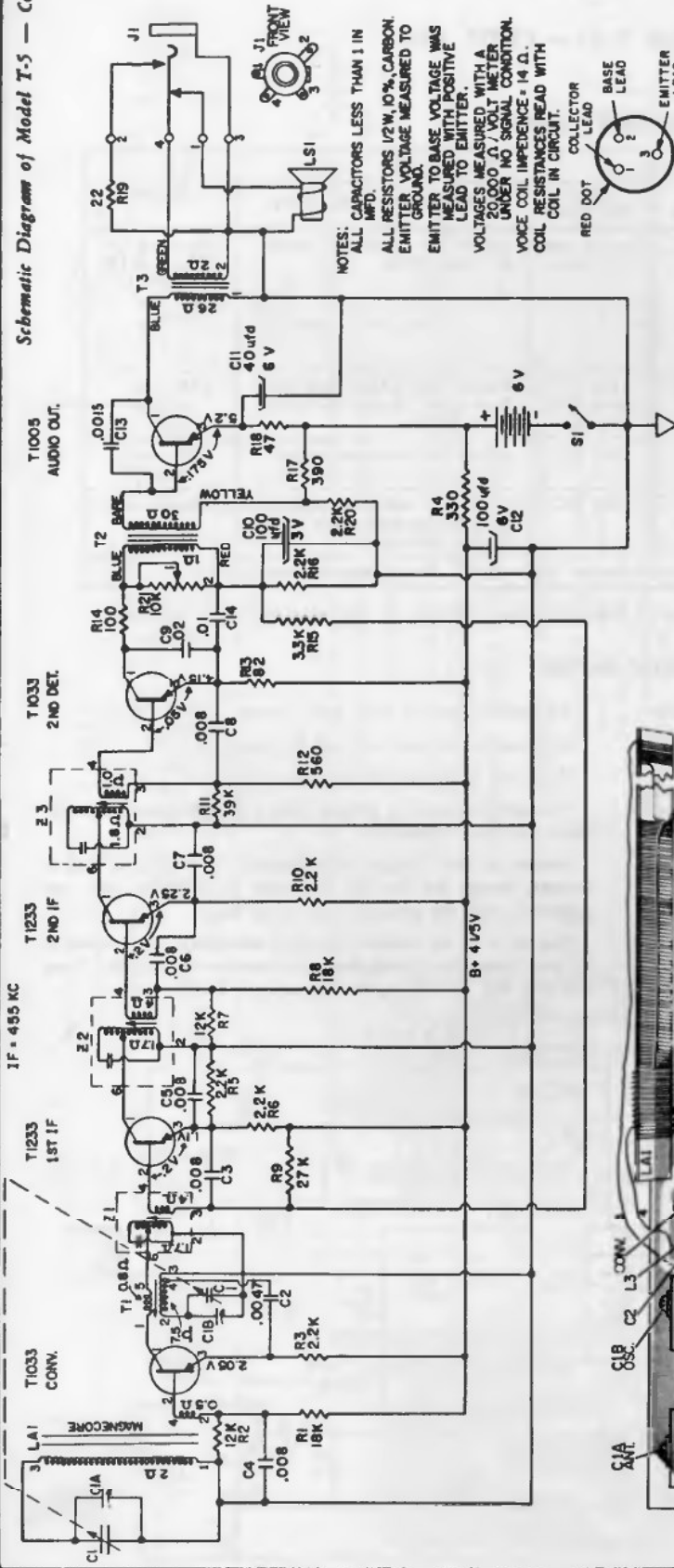

NOTES:
 ALL CAPACITORS LESS THAN 1 IN MFD.
 ALL RESISTORS 1/2 W, 10% CARBON. EMITTER VOLTAGE MEASURED TO GROUND.
 EMITTER TO BASE VOLTAGE WAS MEASURED WITH POSITIVE LEAD TO EMITTER.
 VOLTAGES MEASURED WITH A 20,000 Ω / VOLT METER UNDER NO SIGNAL CONDITION.
 VOICE COIL IMPEDANCE = 14 Ω.
 COIL RESISTANCES READ WITH COIL IN CIRCUIT.



TERMINAL LUG IDENTIFICATION

- L1 Orange jumper to L4, 5 volt B+.
- L2 Yellow lead to T2.
- L3 To short antenna lead no. 4.
- L4 Orange jumper to L1, 4.5 volt B+.
- L5 Black jumper to ground lug 110.
- L6 Black lead to positive battery terminal (6 volts).
- L7 Green lead to end (No. 2) of R21.
- L8 Orange lead to L5.
- L9 Blue lead of T3.
- L10 Ground lug: black lead to speaker, black lead to L5 and black lead to on-off switch.

PRIVATE LISTENING JACK TERMINAL LEADS

- Terminal 1—Brown lead to speaker.
- Terminal 2—One end of R19, P.L. shunt resistor.
- Terminal 3—Black ground lead to on-off switch and other end of R19.
- Terminal 4—Green lead of T3.

NOTE: C14 wires under the panel, from L8 to the junction of C9 and the emitter (No. 3) of the 2nd detector.

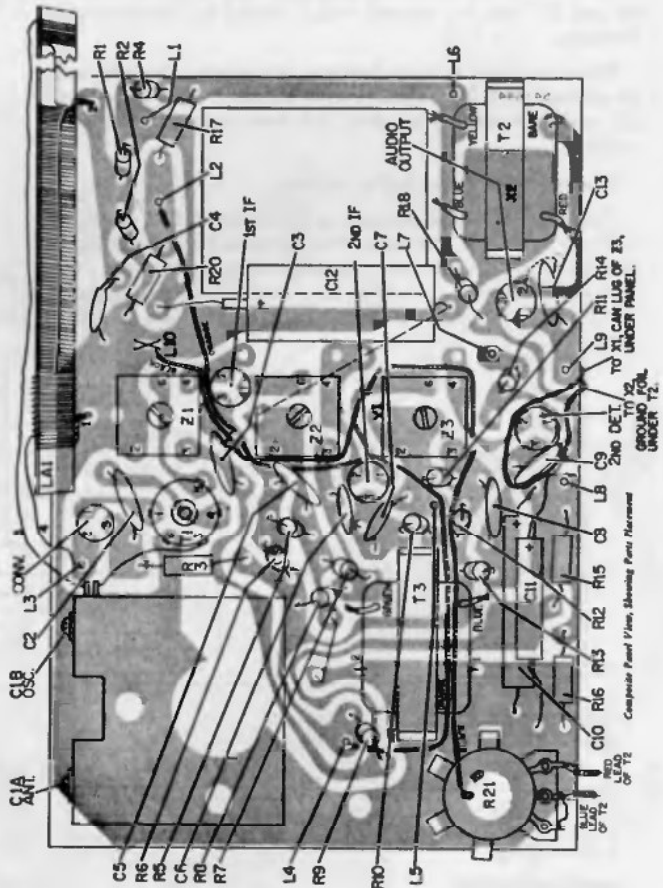

PHILCO

TRANSISTOR MODEL T-7X, CODE 128

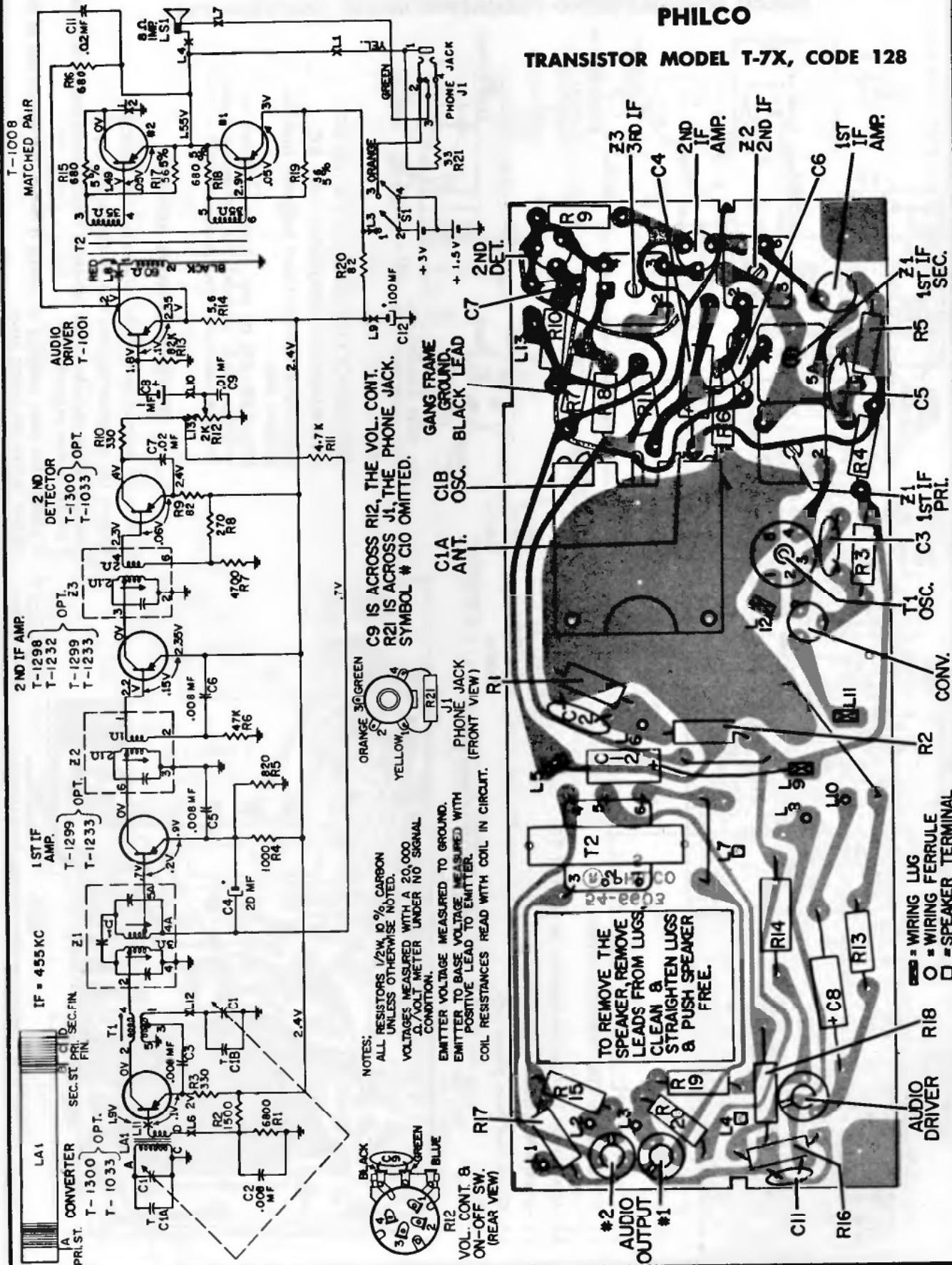

PHILCO PORTABLE RADIO TRANSISTOR MODEL T-60, CODE 124

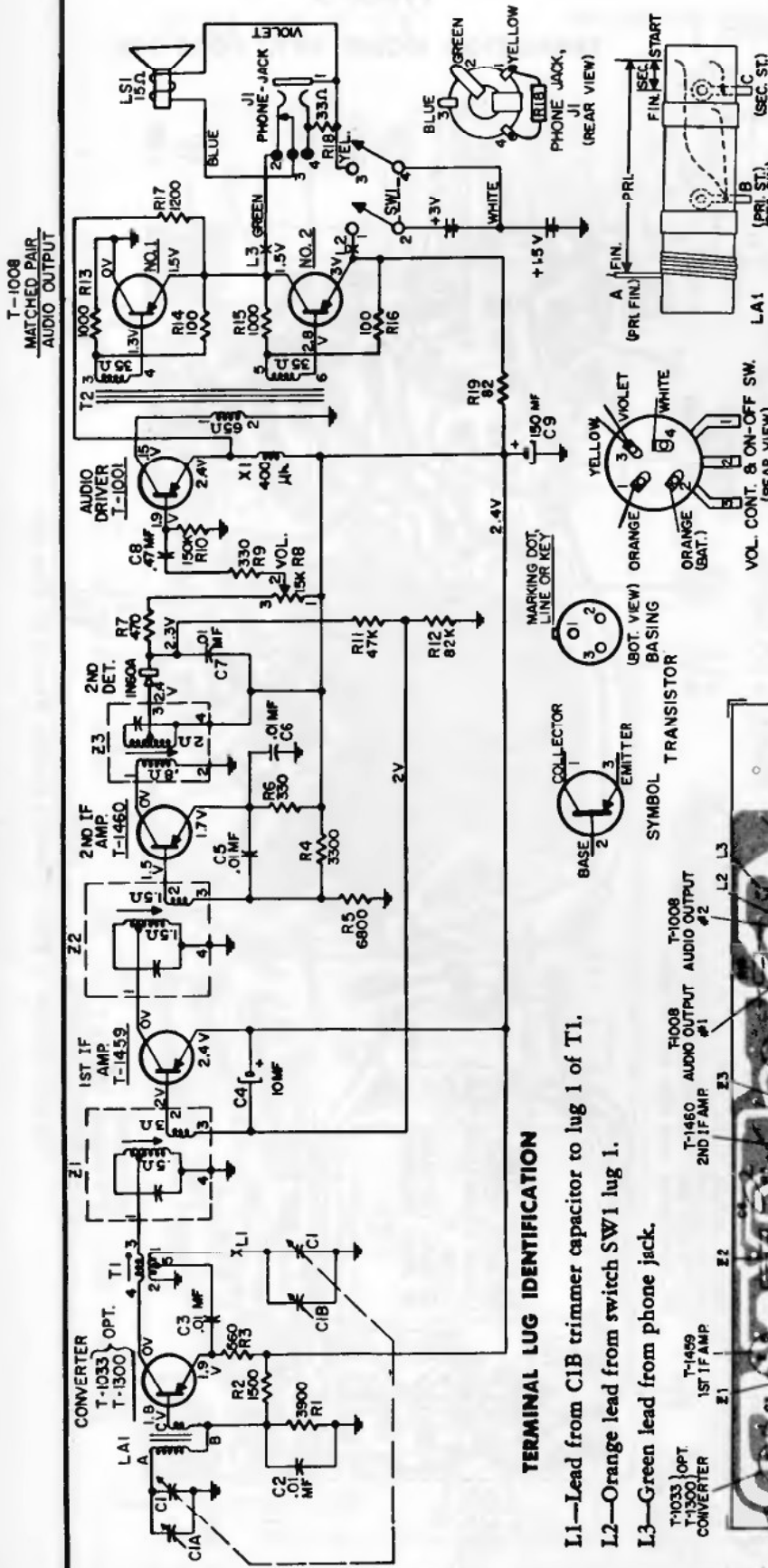

TERMINAL LUG IDENTIFICATION

- L1—Lead from C1B trimmer capacitor to lug 1 of T1.
- L2—Orange lead from switch SW1 lug 1.
- L3—Green lead from phone jack.



MARKING DOT LINE OR KEY

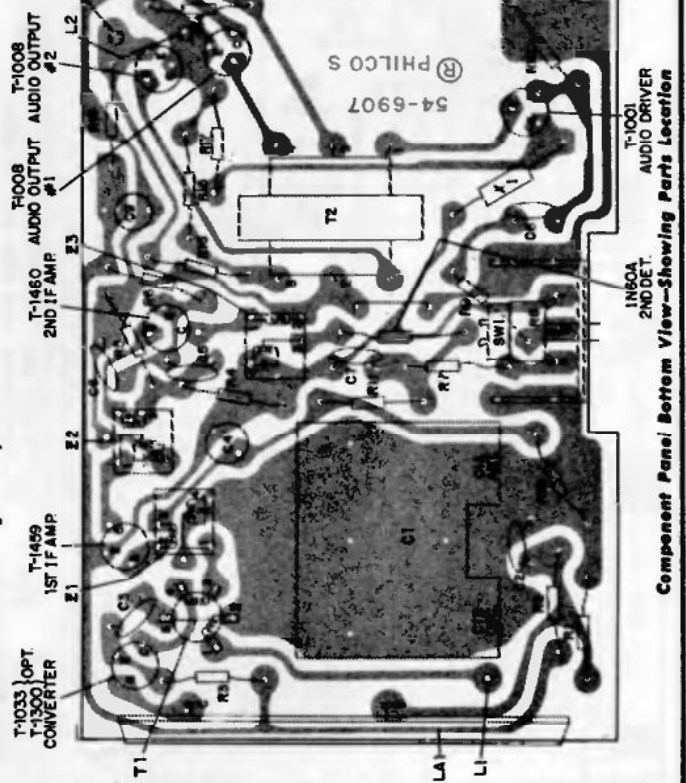

FREQUENCY COVERAGE—535 to 1620 KC.
INTERMEDIATE FREQUENCY—455 KC.
ANTENNA—Self-contained magnator, high-impedance loop.
SPEAKER—2 3/4 in. pm., 15 ohm voice coil impedance. Jack provided for optional private listening attachment, part number 42-1975-4.

PRINTED-WIRE PANEL REMOVAL

1. Remove the snap-on back of the cabinet and the batteries.
2. Remove the tri-mount fastener next to the battery clips.
3. Carefully spread the sides of the cabinet to free the panel from each of the 4 slotted cabinet supports.
4. Withdraw the panel assembly by sliding it toward the speaker end of the cabinet to free the tuning knob.

PHILCO TRANSISTOR RADIO — MODEL T-65

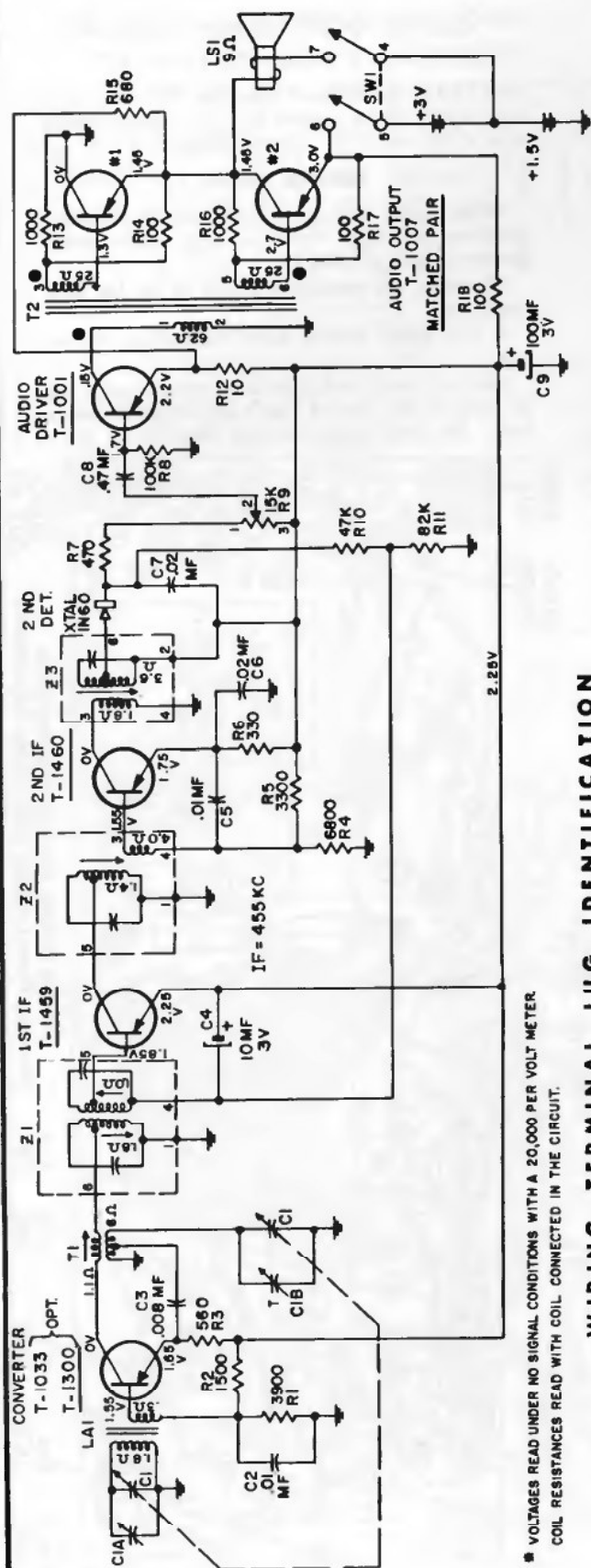

* VOLTAGES READ UNDER NO SIGNAL CONDITIONS WITH A 20,000 PER VOLT METER. COIL RESISTANCES READ WITH COIL CONNECTED IN THE CIRCUIT.

WIRING TERMINAL LUG IDENTIFICATION

- L1 Black lead, battery ground.
- L2 Orange lead, 1.5V battery.
- L3 Red lead, 3.0V battery.
- L4 Green lead, audio output to speaker.
- L5 Red antenna lead, low side of secondary, lead #3.
- L6 Red antenna lead, high side of secondary, lead #4.
- Antenna lead, high side of primary to ant. section of gang, lead #1.
- Antenna lead, low side of primary to gang ground lug, lead #2.
- Orange lead from speaker to terminal #7 of S1.

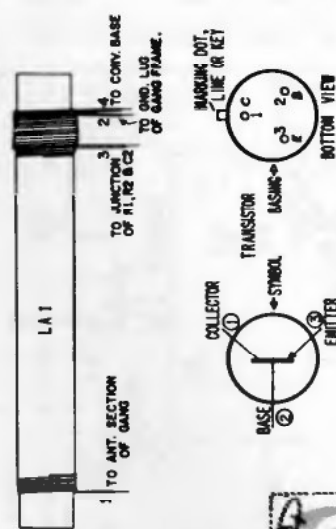

AUDIO OUTPUT—0.1 watt.

BATTERY VOLTAGE AND TYPE—3.0 volts from 2 standard "D" cells.

FREQUENCY COVERAGE—535 - 1620 KC.

INTERMEDIATE FREQUENCY—455 KC.

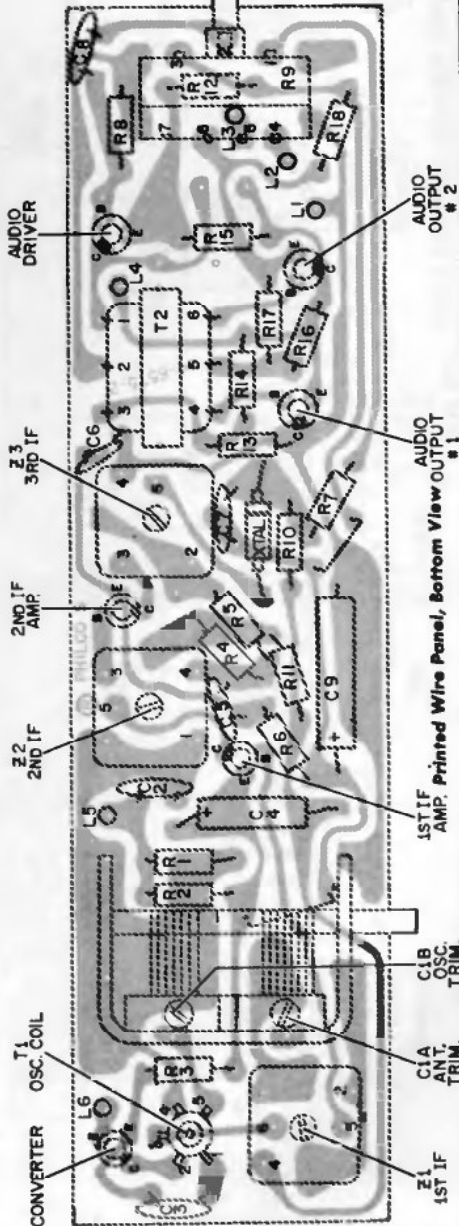

PHILCO PORTABLE RADIO MODEL T-75, CODE 124

FREQUENCY COVERAGE—535 to 1620 KC.

INTERMEDIATE FREQUENCY—455 KC.

BATTERY SUPPLY—2 standard "D" cells, in 3 volt supply center tapped at 1-1/2 volts. Battery type P-907 or P-920 (metal clad).

SERVICE NOTES

When signal tracing, inject signal at transistor collector and limit input to keep signal across speaker below .6 volts.

Normally, the transistors should be the last item suspected.

If C12 opens serious audio oscillation will result.

Dress of black lead from top, center, frame lug of gang to end ground lug is important to reduce beat. See base layout for lead dress.

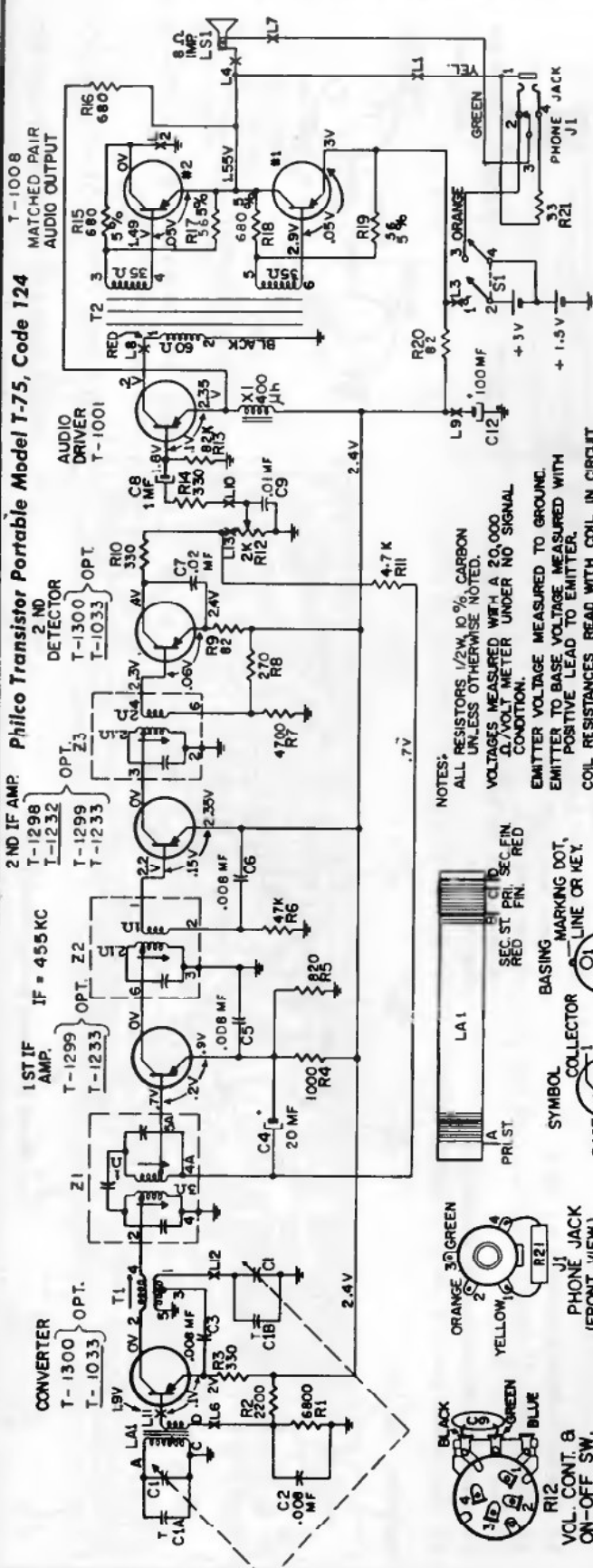

NOTES:
 ALL RESISTORS 1/2W, 10% CARBON UNLESS OTHERWISE NOTED.
 VOLTAGES MEASURED WITH A 20,000 Ω/V OLTMETER UNDER NO SIGNAL CONDITION.
 EMITTER VOLTAGE MEASURED TO GROUND.
 EMITTER TO BASE VOLTAGE MEASURED WITH POSITIVE LEAD TO EMITTER.
 COIL RESISTANCES READ WITH COIL IN CIRCUIT.

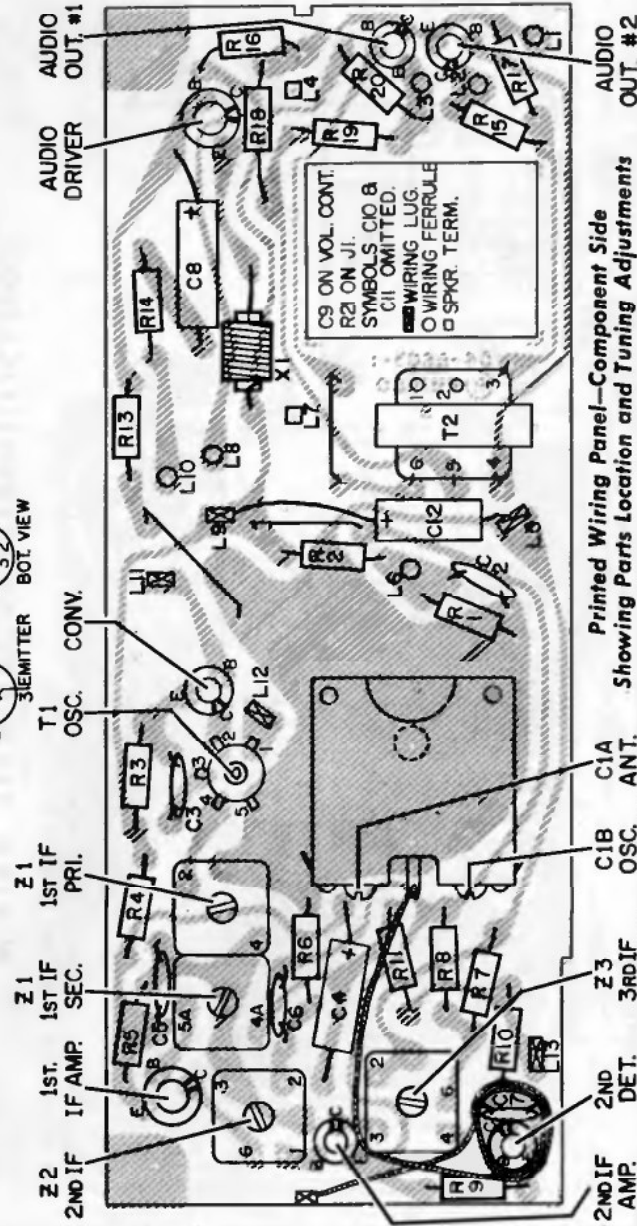
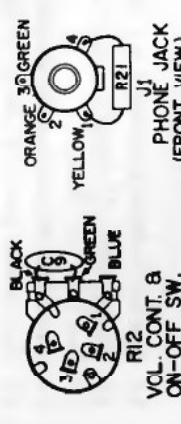
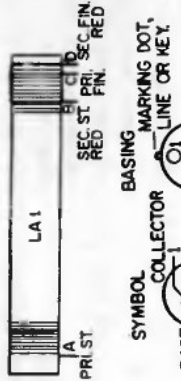

Printed Wiring Panel—Component Side
 Showing Parts Location and Tuning Adjustments

PHILCO RADIO

AM/FM TUNER—TYPE RT-202

Electrically all chassis are identical except the RT-202-2 and the RT-202-4. The RT-202-4 chassis contains a 560 ohm resistor and .01 mfd capacitor from the cathode of the AM-RF amplifier (V7) to ground. Lug L1 on the printed wire panel of the RT-202-4 chassis is grounded, thus returning the secondary of T10 and condenser C43 to ground instead of the AVC circuit. The RT-202-2 chassis uses an AM antenna coil while the remaining chassis use a magnecore antenna.

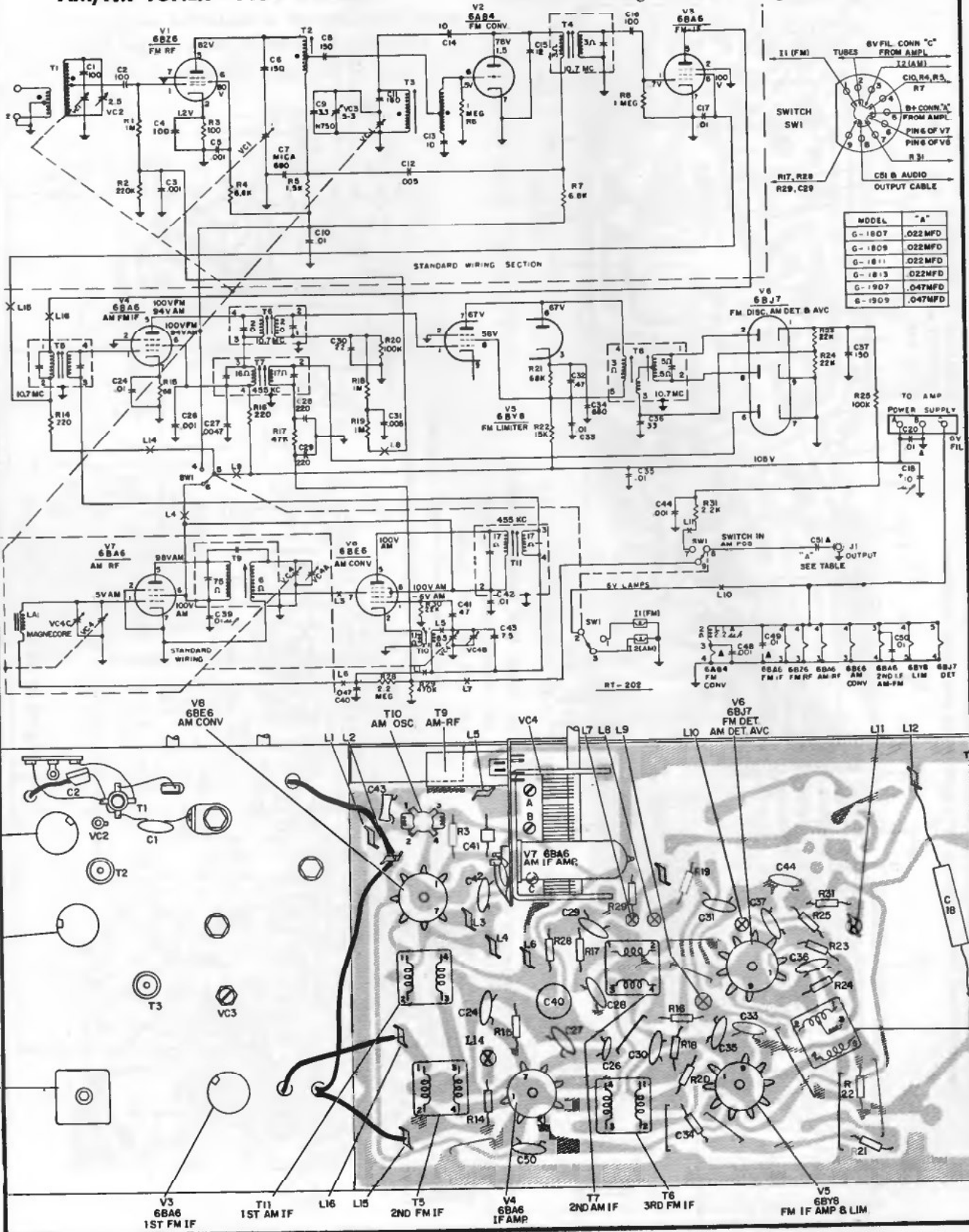

Top View — Showing Alignment Points, Tube Locations and Tie Lugs

PHILCO PORTABLE RADIO MODEL G-681, CODE 124

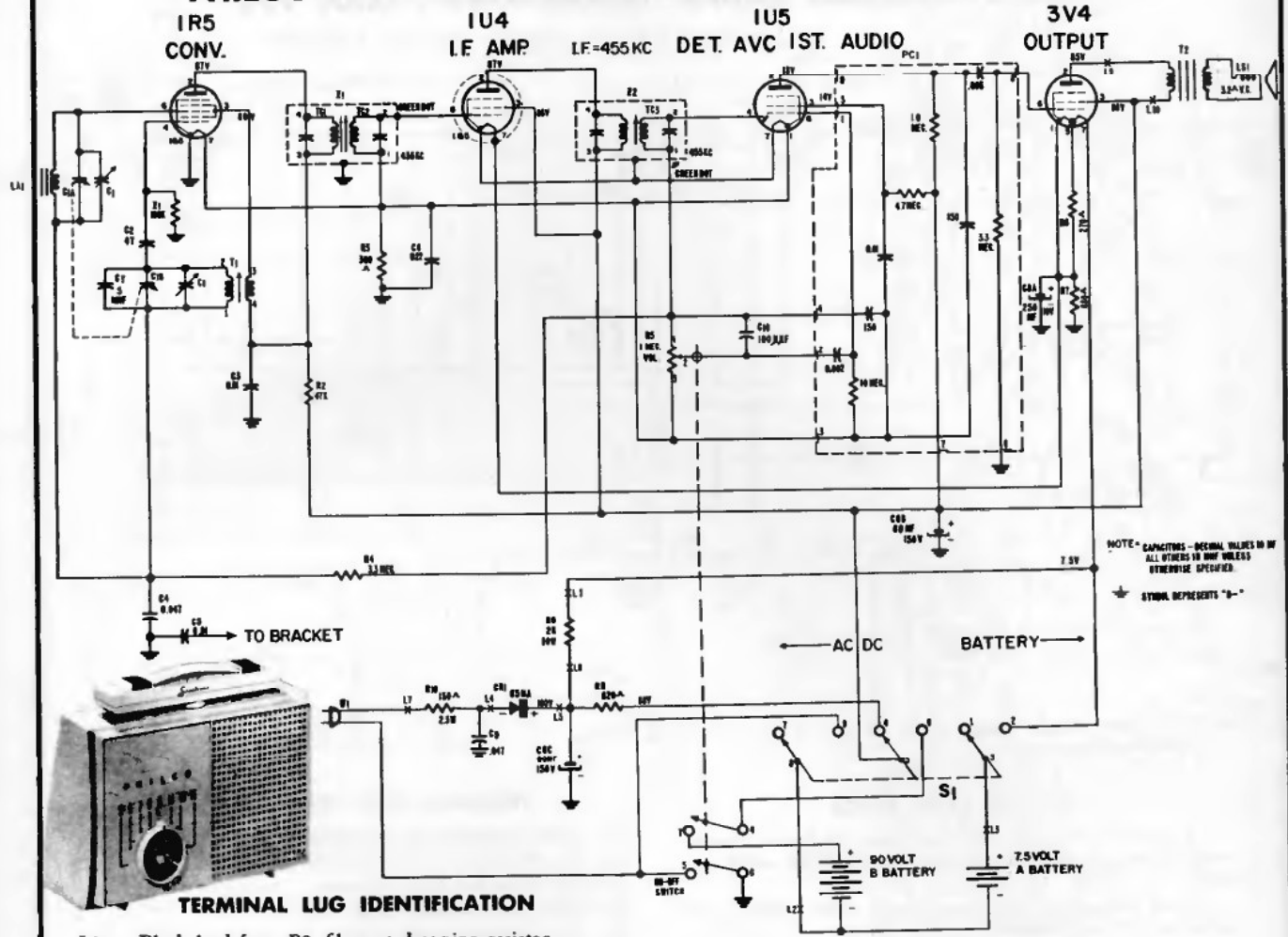

TERMINAL LUG IDENTIFICATION

- L1 Black lead from R9, filament dropping resistor.
- L2 B—, black lead from "A" battery and yellow lead from "B" battery.
- L3 A+, brown lead from "A" battery.
- L4 Black lead to selenium rectifier, CR1.
- L5 B+, red lead from CR1.
- L6 Brown lead to filament dropping resistor, R9.
- L7 White lead from AC interlock to R10.
- L8 Blue lead to L11, ground.
- L9 Blue lead from 3V4 plate to output trans., T2.
- L10 Red lead to output transformer, T2.
- L11 Blue lead to L8, ground.
White lead from AC interlock to lug 5 of ON-OFF switch.
Red lead from "B" battery to lug 7 of ON-OFF switch.

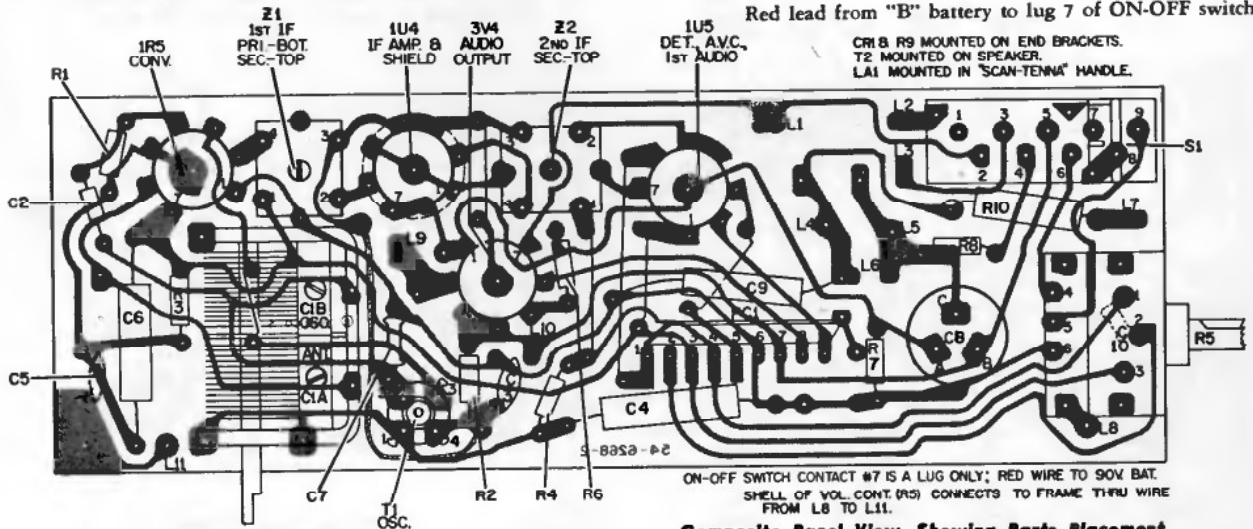

Composite Panel View, Showing Parts Placement

PHILCO PORTABLE RADIO MODEL H-691, CODE 124

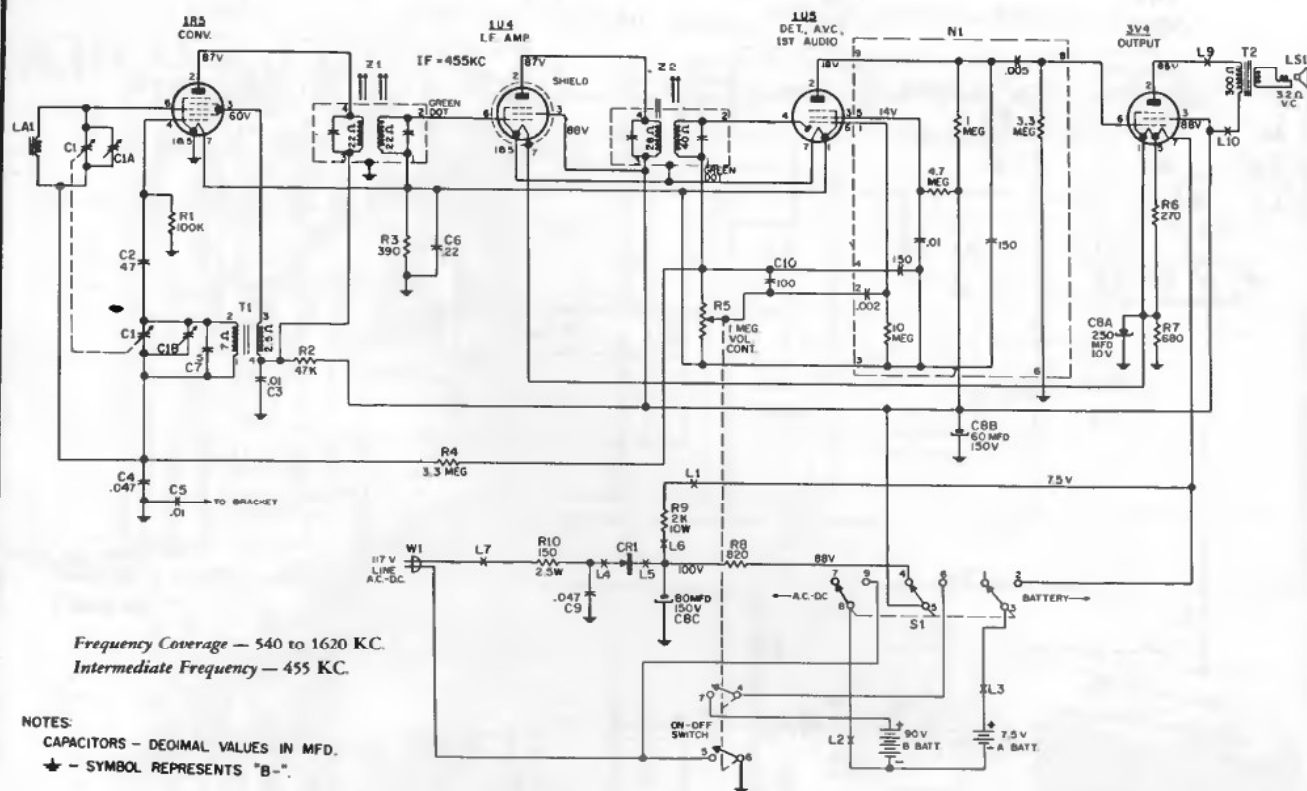

Frequency Coverage — 540 to 1620 KC.
Intermediate Frequency — 455 KC.

NOTES:

CAPACITORS — DECIMAL VALUES IN MFD.
★ — SYMBOL REPRESENTS "B-".

CRITICAL LEAD DRESS

1. Brown and black wires, from wiring panel on bracket, must be dressed below and away from R9 and in front of the tuning condenser, C1.
2. Brown and black "A" battery leads must be dressed over the output transformer, T2, and through the dress lug.
3. Red and yellow "B" battery leads must be dressed up through the AC interlock mounting bosses.
4. White AC interlock leads must be dressed toward the front panel.
5. All wires must be dressed clear of the current limiting resistor, R10.
6. C6, the filament condenser, must be dressed toward the bracket, away from C1, the tuning gang.

TERMINAL LUG IDENTIFICATION

- L1 Black lead from R9, filament dropping resistor.
 - L2 B-, black lead from "A" battery and yellow lead from "B" battery.
 - L3 A+, brown lead from "A" battery.
 - L4 Black lead to selenium rectifier, CR1.
 - L5 B+, red lead from CR1.
 - L6 Brown lead to filament dropping resistor, R9.
 - L7 White lead from AC interlock to R10.
 - L8 Blue lead to L11, ground.
 - L9 Blue lead from 3V4 plate to output trans., T2.
 - L10 Red lead to output transformer, T2.
 - L11 Blue lead to L8, ground.
- White lead from AC interlock to lug 5 of ON-OFF switch.
Red lead from "B" battery to lug 7 of ON-OFF switch.

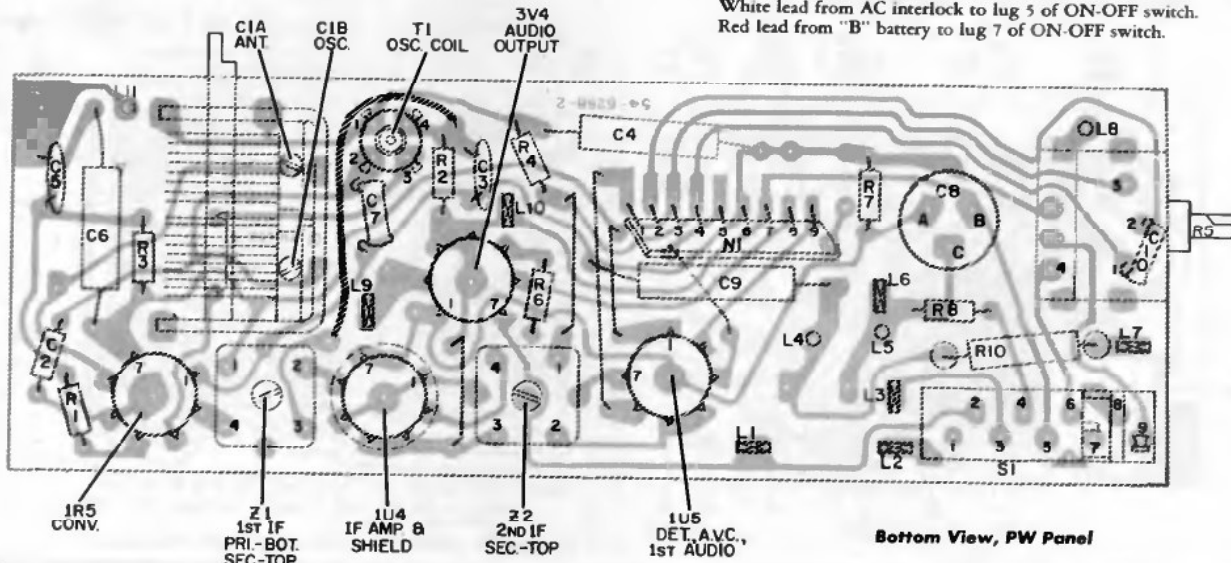

Bottom View, PW Panel

PHILCO

MODELS G-749, G-751, G-753 and G-755

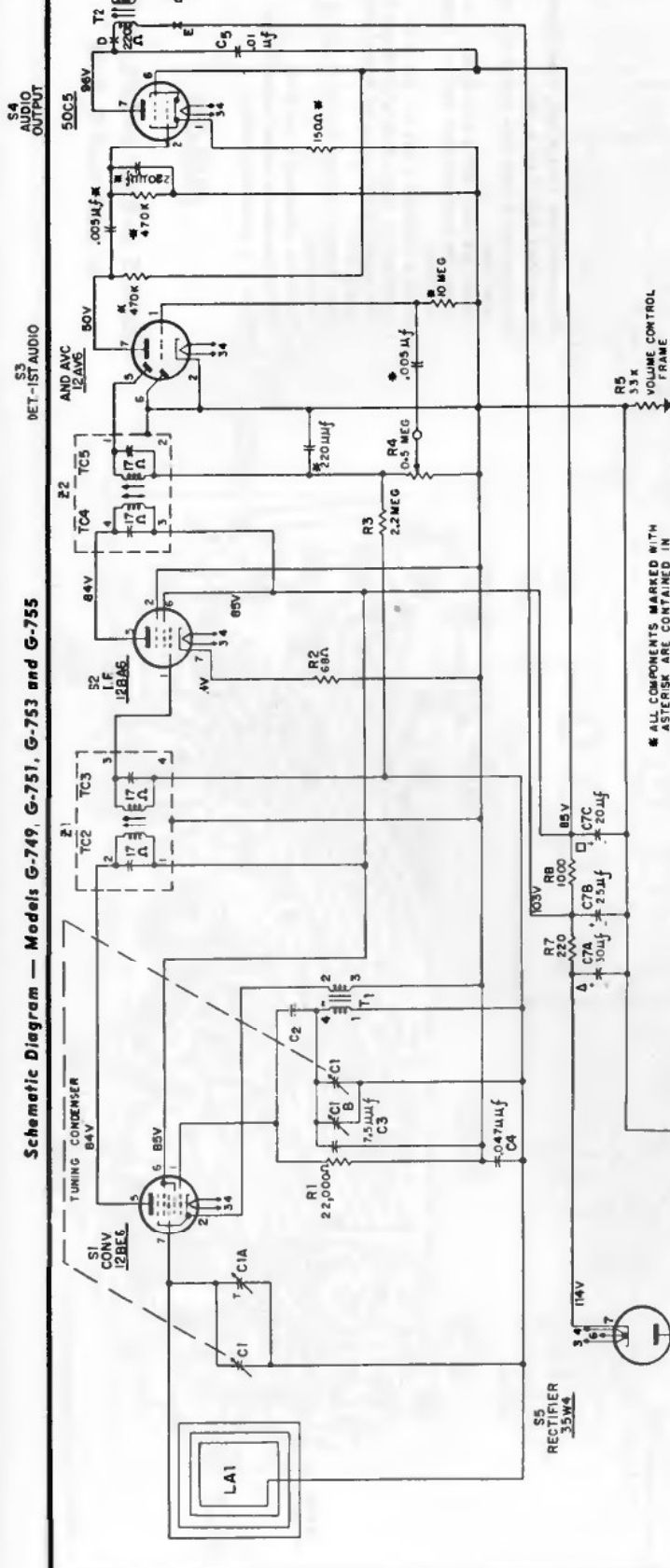

Schematic Diagram — Models G-749, G-751, G-753 and G-755

Frequency Range—540 KC to 1620 KC.
Intermediate Frequency—455 KC.

* ALL COMPONENTS MARKED WITH
ASTERISK ARE CONTAINED IN
I UNIT (M)

C2 IS PART OF OSC. COIL.

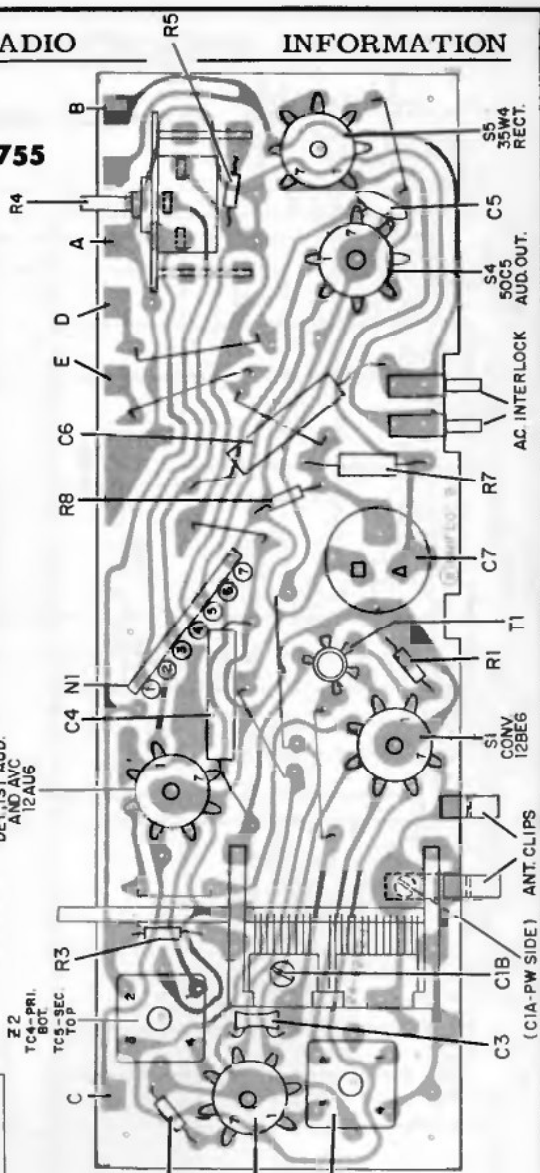

Printed Panel Component Layout — Models G-751, G-753 and G-755

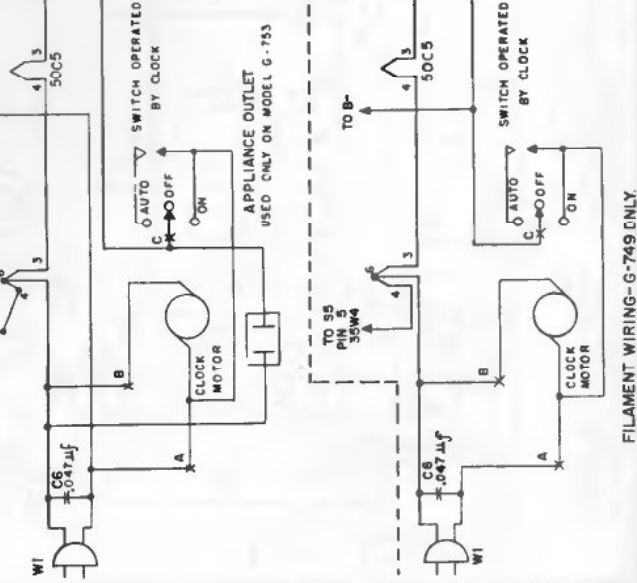

FILAMENT WIRING—G-749 ONLY.

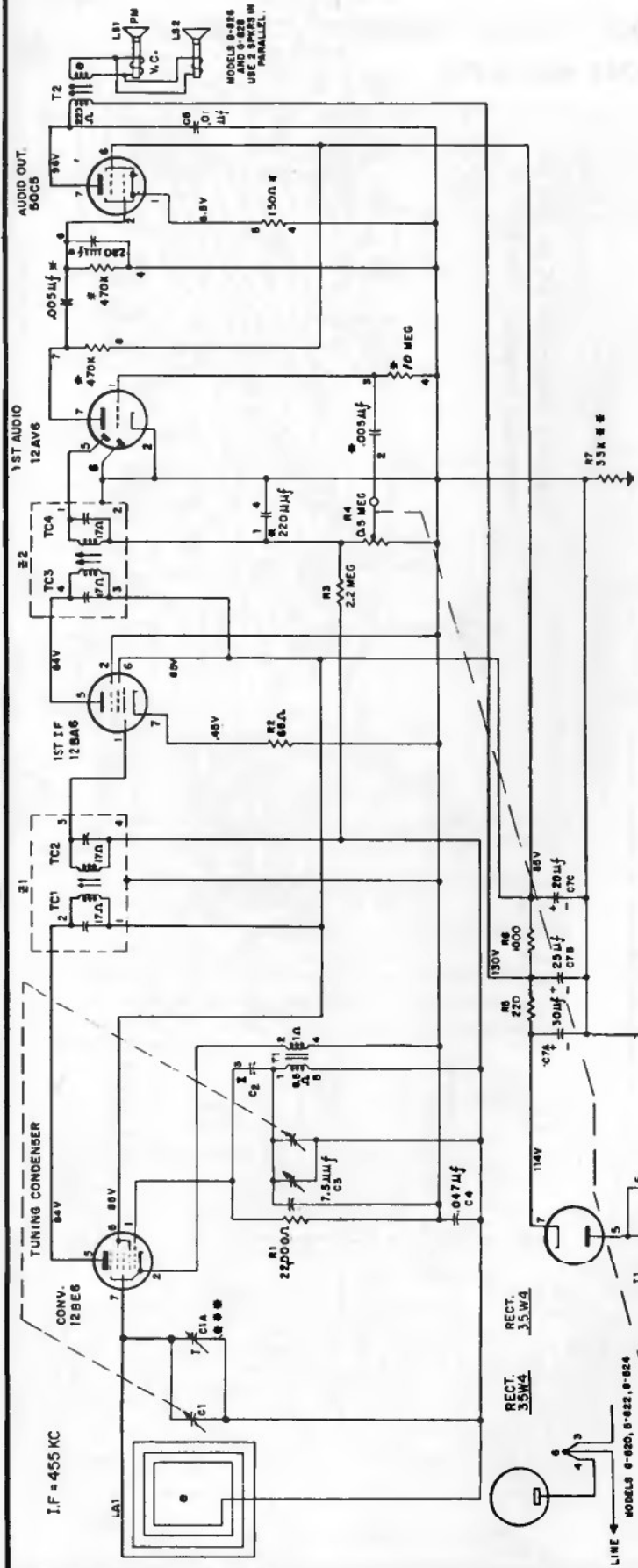

NOTES:
 All capacitors over 1 are in mmf, unless otherwise noted.
 All capacitors under 1 are in mfd.
 All resistors are 1/2 watt, 10%, carbon type, unless otherwise noted.
 Voltages are taken with a 20,000 ohm/volt meter, between the point indicated and B —, under no-signal condition.
 ⊕ Indicates a resistance of less than one ohm.
 ††, pilot light, is used in Models G-826 and G-828 only. See insert of 35W4 wiring for Models G-820, G-822, and G-824.
 Models G-826 and G-828 have two speakers connected in parallel.
 *Indicates component is part of N1.
 **R7 is grounded to volume control frame.
 ***CIA is on underside of panel.

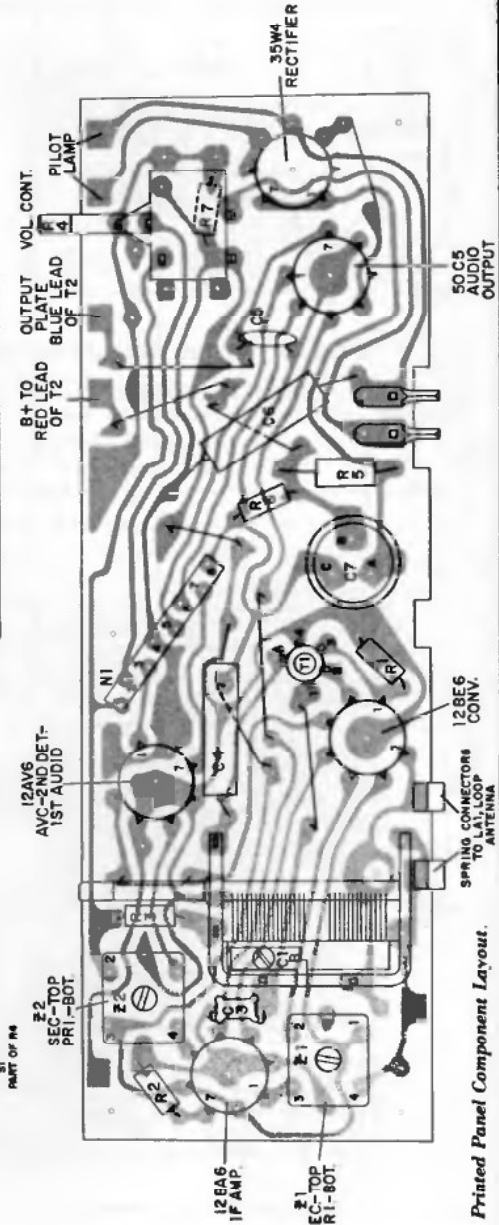

Printed Panel Component Layout.

PHILCO
MODELS G-820, G-822, G-824,
G-826 and G-828

PHILCO AM/FM MODEL G-974

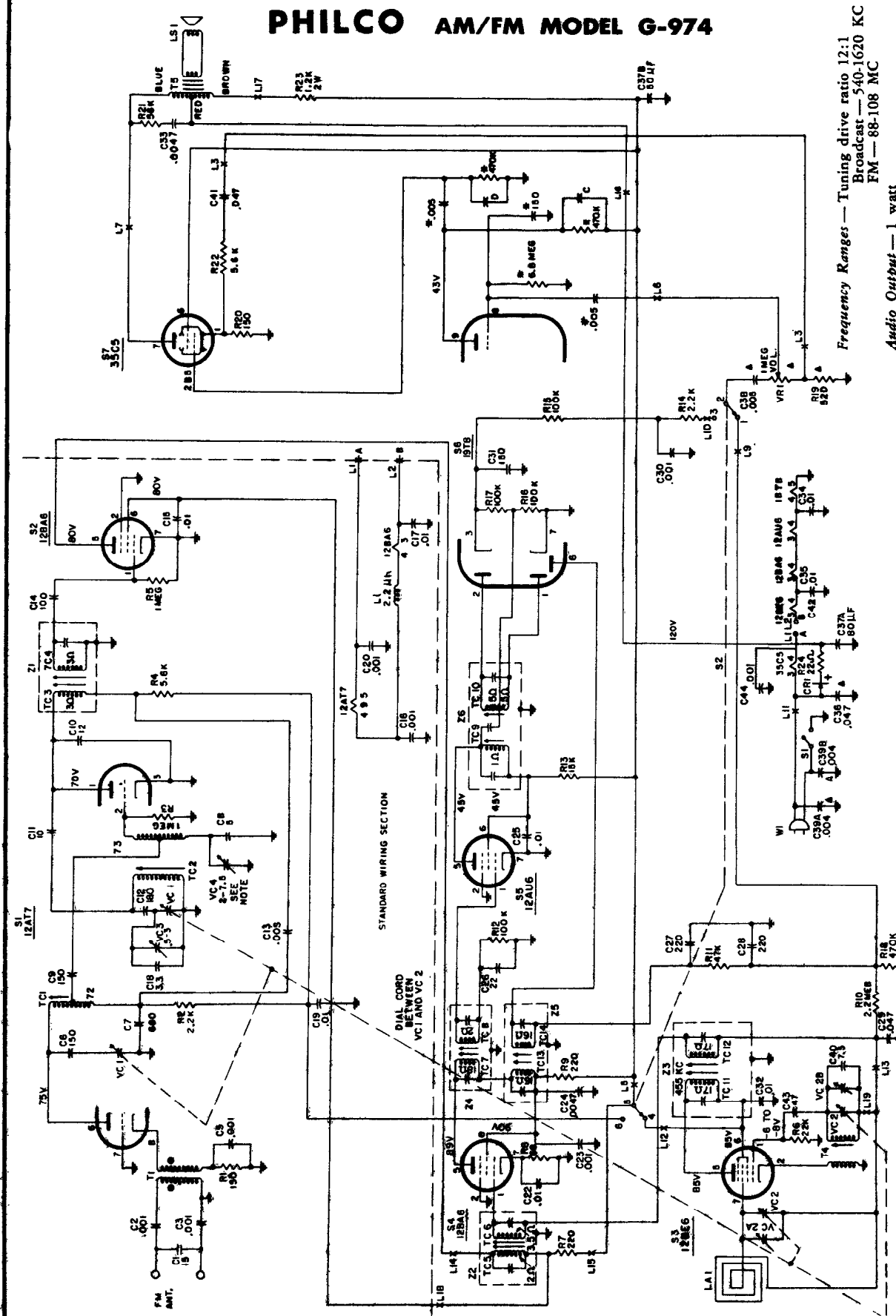

Frequency Ranges — Tuning drive ratio 12:1
 Broadcast — 540-1620 KC
 FM — 88-108 MC

Audio Output — 1 watt
 Operating Voltage — 105 - 120 volts, a.c./d.c.
 Power Consumption — 40 watts
 Intermediate Frequency — AM 455 KC
 FM 10.7 MC

VC4 IS A FACTORY ADJUSTMENT AND SHOULD NOT REQUIRE FUTURE ADJUSTMENT UNLESS REPLACED. IT MINIMIZES OSCILLATOR RADIATION. TO ADJUST, TUNE RATIO TO 100 MC AND ADJUST VC4 FOR MINIMUM INDICATION ON A FIELD STRENGTH METER TUNED TO THE OSC FREQ.

ALL RESISTORS ARE 1/2 WATT, 10% UNLESS OTHERWISE NOTED.
 ALL CAPACITORS ABOVE ARE IN μ F UNLESS OTHERWISE NOTED, ALL CAPACITORS BELOW ARE μ .

* COUPLATE NI
 ▲ PART OF STANDARD WIRING
 ▲ INDICATES LESS THAN 1 OHM
 CONDENSERS C + D = 150 μ F

PHILCO RADIO AM/FM MODEL G-978

Schematic Diagram Model G-978

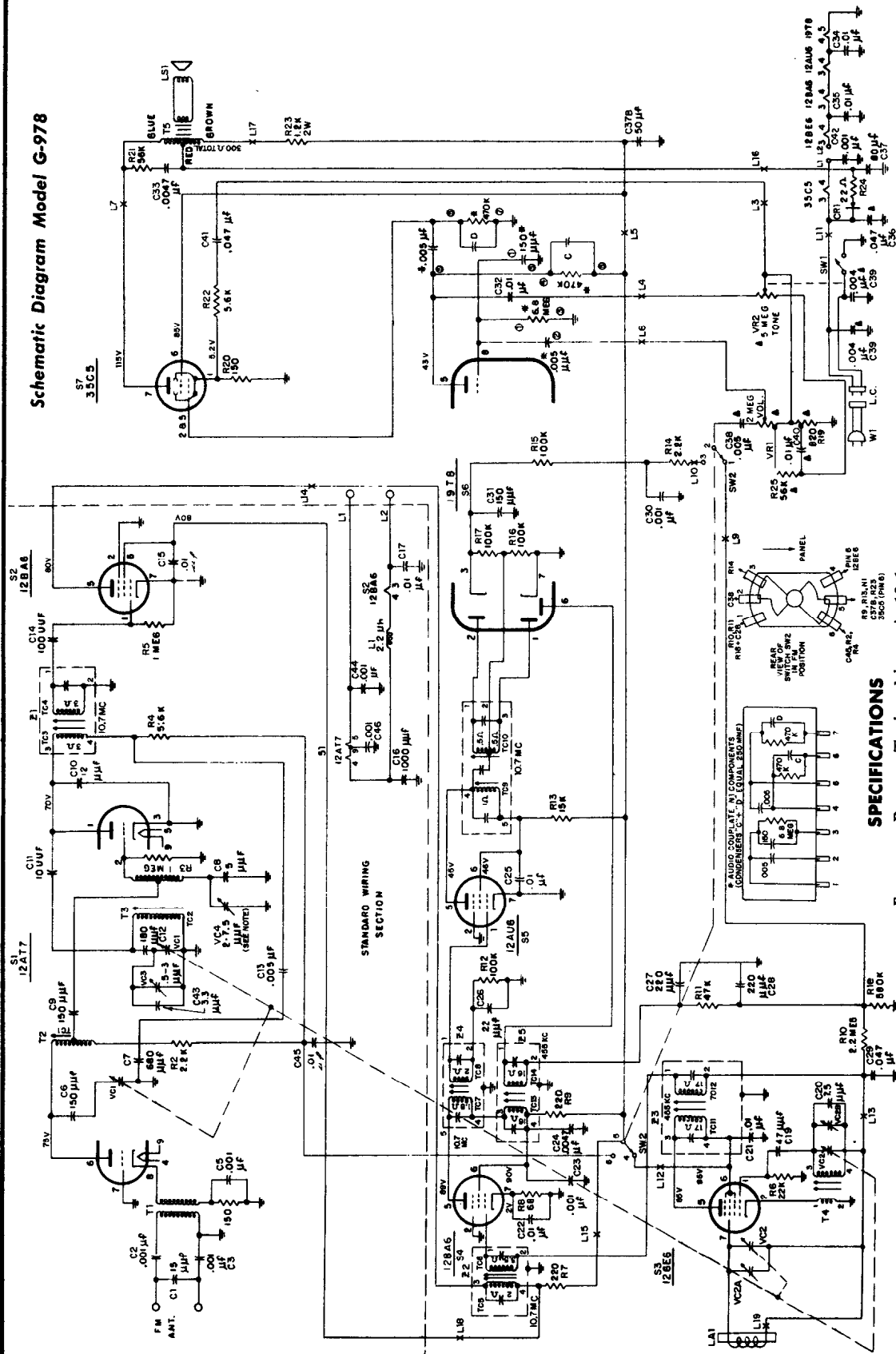

KNOB REMOVAL—The control knobs of the Model G-978 are mounted on the notched control shafts with spring clips which lock the knobs in position. To remove the knobs, release the spring clip with a screw driver blade before pulling the knob from the shaft.

SPECIFICATIONS
 Frequency Ranges—Tuning drive ratio 12:1
 Broadcast—540-1620 KC
 FM—88-108 MC
 Audio Output—1 watt
 Variable bass boost or treble cut tone control.
 Power Consumption—40 watts.
 Intermediate Frequency—AM 455 KC.
 FM 10.7 MC.

Components marked ▲ are part of chassis wiring.
 ● indicates less than 1 ohm.
 All resistors are 1/2 watt, 10% unless otherwise noted.
 VC4 is a factory adjustment and should not require future adjustment unless replaced. It minimizes oscillator radiation. To adjust, tune radio to 100 MC and adjust VC4 for minimum indication on a field strength meter tuned to the oscillator frequency.

PHILCO RADIO MODEL G-978 AM/FM RECEIVER

PHILCO PHONOGRAPH MODEL G-1410

SPECIFICATIONS

AUDIO OUTPUT—1.0 watt each channel.
OPERATING VOLTAGE—105-125 volts, 60 cycles a.c.
POWER CONSUMPTION—60 watts.
RECORD CHANGER—M-40, 4 speed automatic record changer with stereophonic pickup.

VOLUME-BALANCE CONTROL

The volume-balance controls for the two amplifier channels are mounted in tandem with concentric shafts. The inner shaft is spring loaded and locked to the outer shaft. Turning the shaft of one control simultaneously turns the shaft of the other control. Pushing in the inner shaft unlocks the controls to permit individual volume control adjustment.

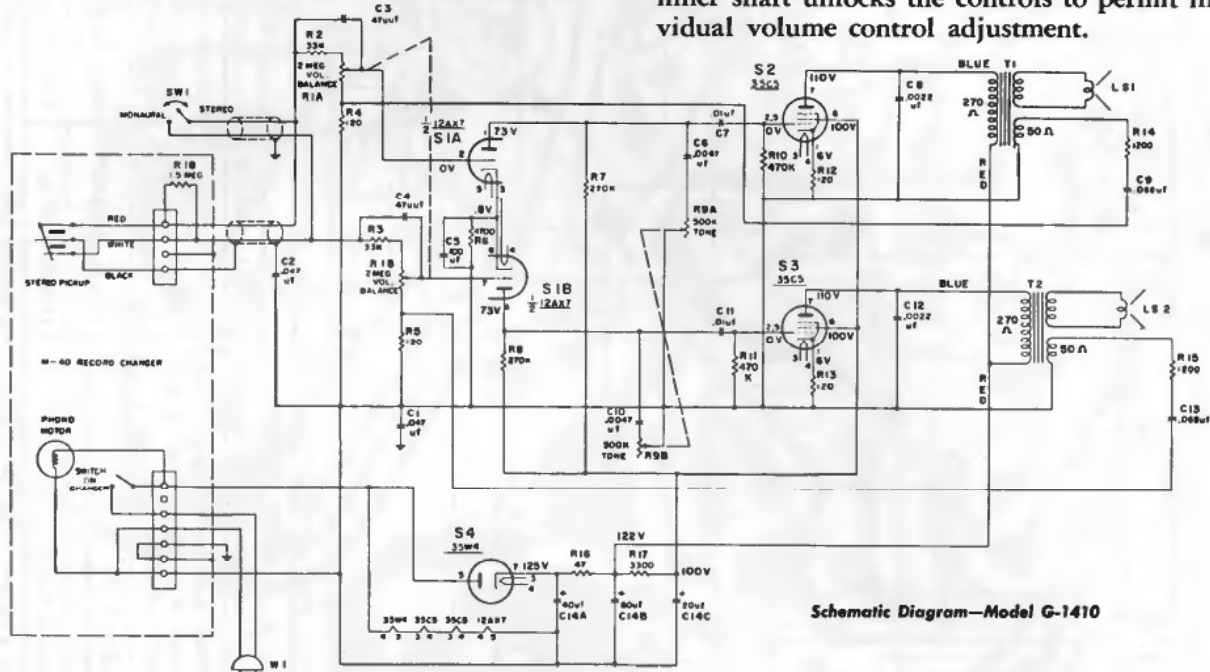

Schematic Diagram—Model G-1410

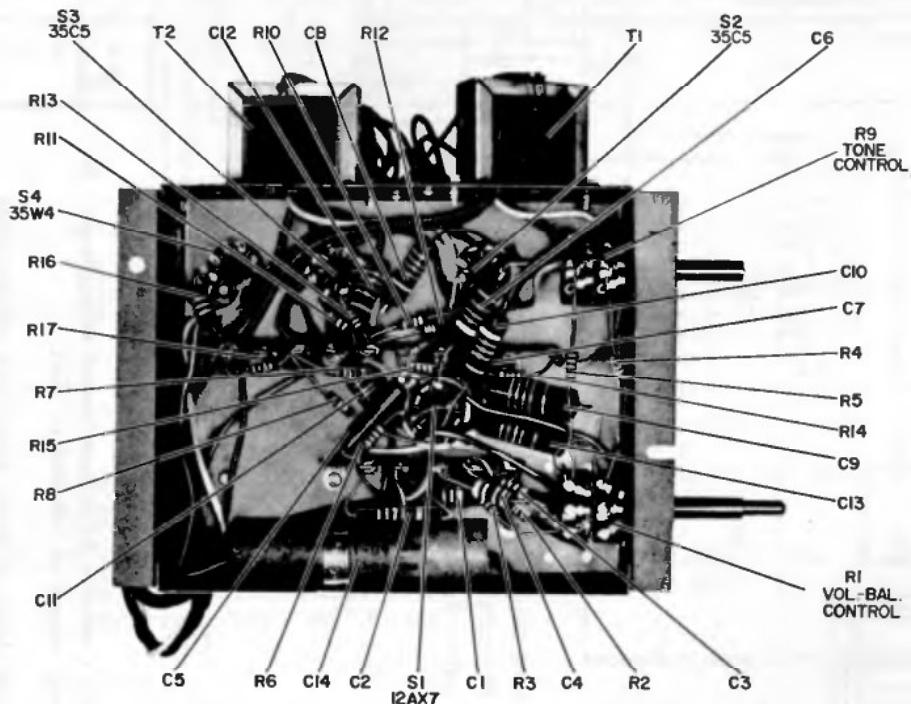

Base View, Components Layout—Model G-1410

PHILCO
MODEL G-1409, CODE 124

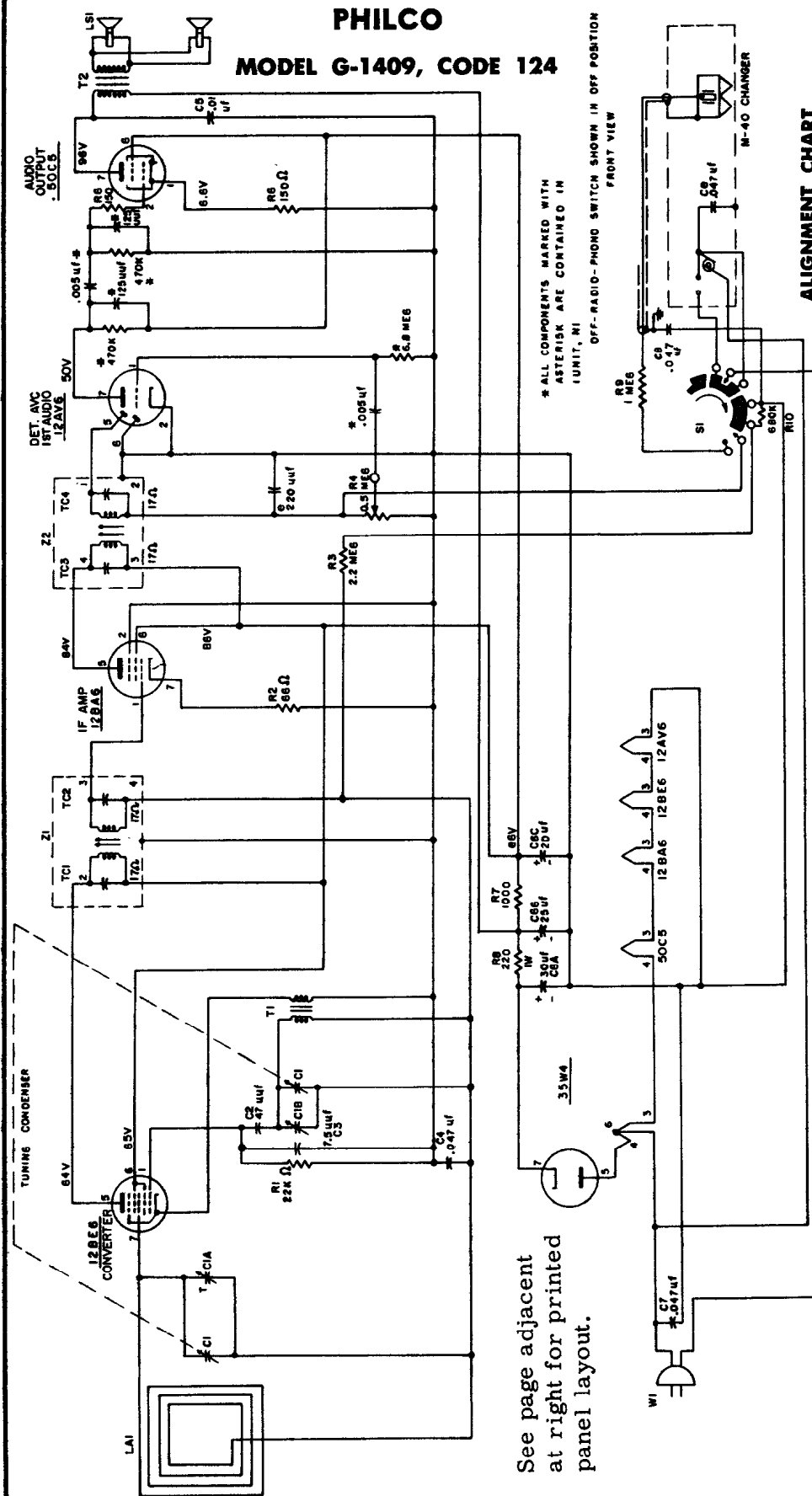

See page adjacent at right for printed panel layout.

* ALL COMPONENTS MARKED WITH ASTERISK ARE CONTAINED IN 1 UNIT, NI

OFF-RADIO-PHONO SWITCH SHOWN IN OFF POSITION FRONT VIEW

ALIGNMENT CHART

| STEP | SIGNAL GENERATOR CONNECTION TO RADIO | | DIAL SETTING | | ADJUST |
|------|--|--------------|-------------------------|---|--|
| | CONNECTION TO RADIO | DIAL SETTING | DIAL SETTING | SPECIAL INSTRUCTIONS | |
| 1. | Ground lead to B-; output lead through a .1 mf condenser to grid (pin 7) of 12BE6. | 455 kc. | Tuning gang fully open. | Adjust tuning cores, in order given, for max. output. TC2 and TC4 are located on top of transformers. | TC4—2nd i-f sec. TC3—2nd i-f pri. TC2—1st i-f sec. TC1—1st i-f pri. |
| 2. | Radiating loop (See note below). | 1620 kc. | 1620 kc.* | Adjust for maximum output. | Cl-B—osc. |
| 3. | Same as Step 2. | 1500 kc. | 1500 kc. | Adjust for maximum output. | Cl-A—aerial. |

ALIGNMENT PROCEDURE

- Radio Controls**—Set volume control to maximum. Set tuning control as indicated in chart.
- Output Meter**—Connect across voice coil terminals.
- Signal Generator**—Connect generator and set frequency as indicated in chart. Use modulated output, 30%.
- Output Level**—During alignment, adjust signal-generator output to hold output-meter reading below .5 volts.

NOTE: Make up a 6-8 turn, 6 inch diameter loop from insulated wire, connected to signal-generator leads, and place near radio loop.
* For proper adjustment of the oscillator trimmer, fully open the tuning gang and insert a .006 inch non-metallic shim between the heel of the rotor and the top of the stator plates. Close the tuning gang sufficiently to hold the shim in place, and then remove

VOLUME R-19, MOST-OFTEN-NEEDED 1959 RADIO SERVICING INFORMATION

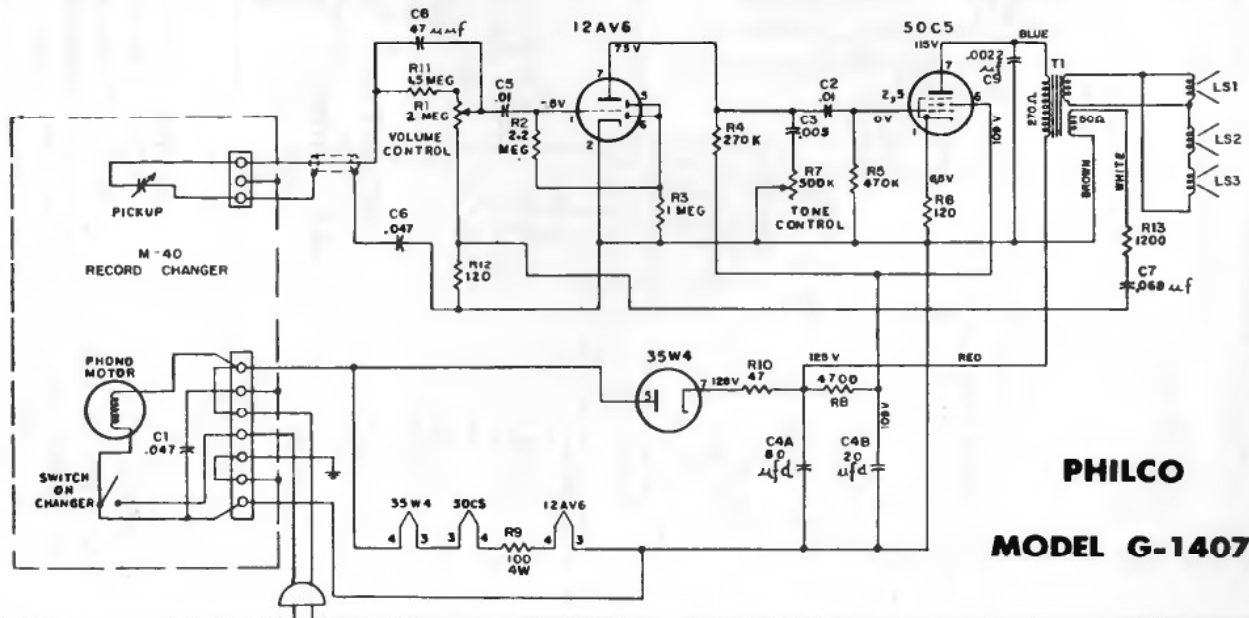
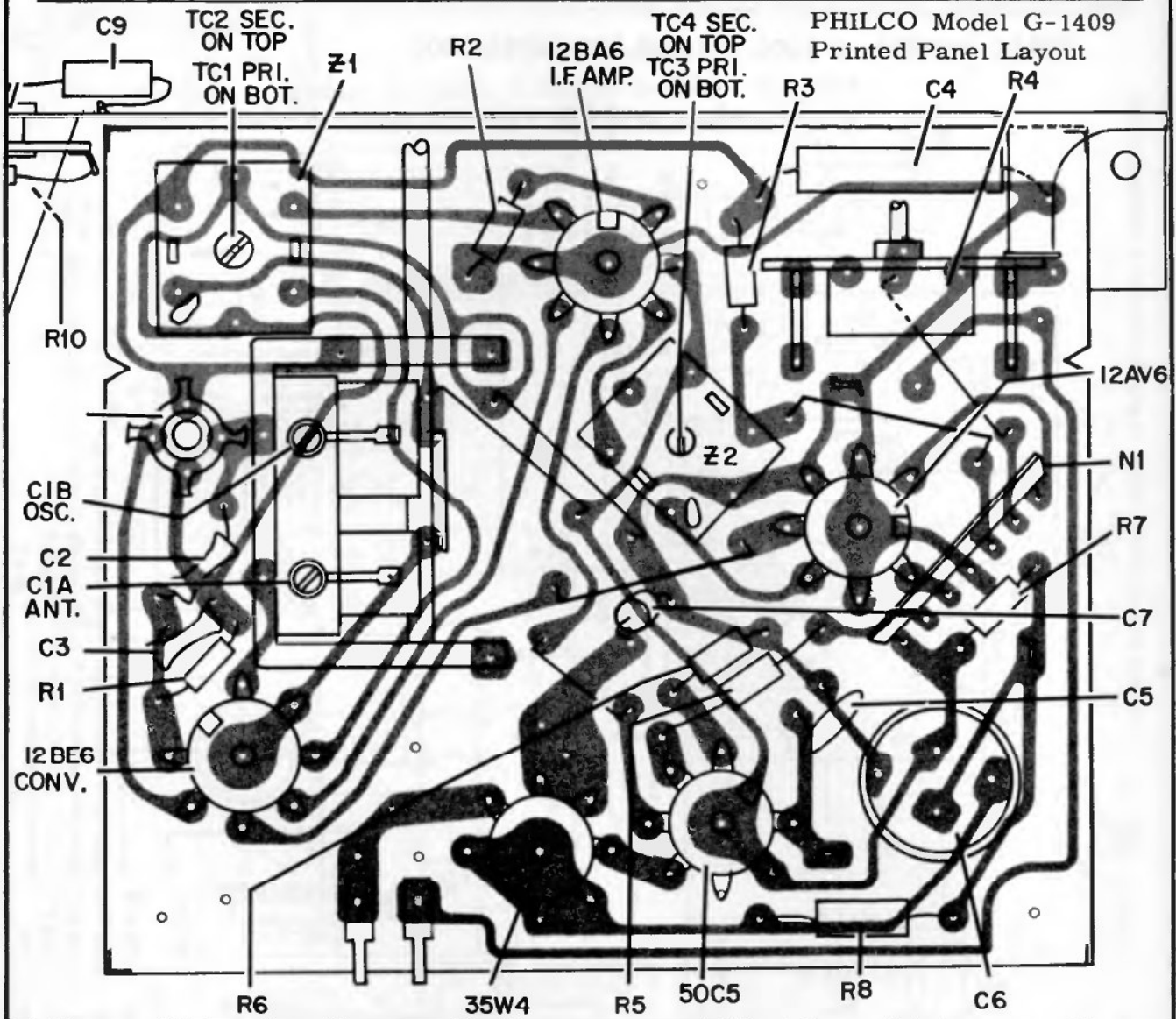

PHILCO MODELS— G-1606, G-1606S-123 and SA-1000

Schematic Diagram, Model G-1606S. (See figures for Models SA-1000 and G-1606)

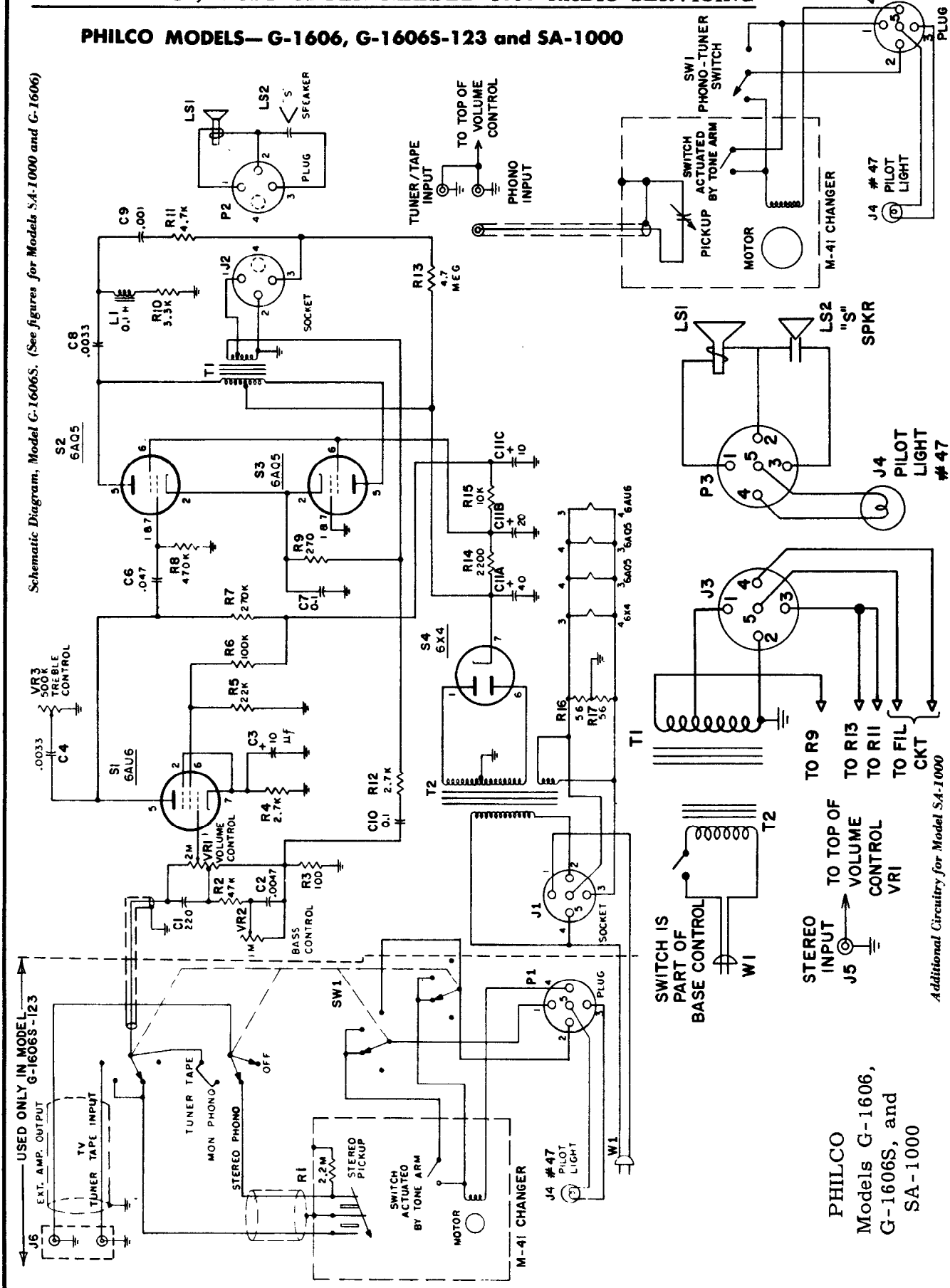

PHILCO
Models G-1606,
G-1606S, and
SA-1000

Additional Circuitry for Model SA-1000

Additional Circuitry for Model G-1606

PHILCO HI-FIDELITY PHONOGRAPHS MODELS G-1706, G-1706S, G-1707, G-1707S, SA-1500 and RT-150

(Continued on the page adjacent at right)

SPECIFICATIONS

NOTE: The G-1706 contains a three-tube-plus rectifier amplifier and a type M-41 record changer. The G-1706S is similar to the G-1706 except the function switch has a stereo position and the M-41 record changer has a stereo cartridge. The G-1707 is a G-1706 with changes to accept a radio tuner. The G-1707 includes an RT-150 AM-FM tuner. The G-1707S is similar to the G-1707 except the function switch has a stereo position and the M-41 record changer has a stereo cartridge. The SA-1500 is the slave amplifier used with the G-1706S or the G-1707S for stereo. Its amplifier is similar to the G-1706 with a different function switch and a-c wiring changes necessitated by the absence of a record changer.

Schematic Diagram of Amplifier

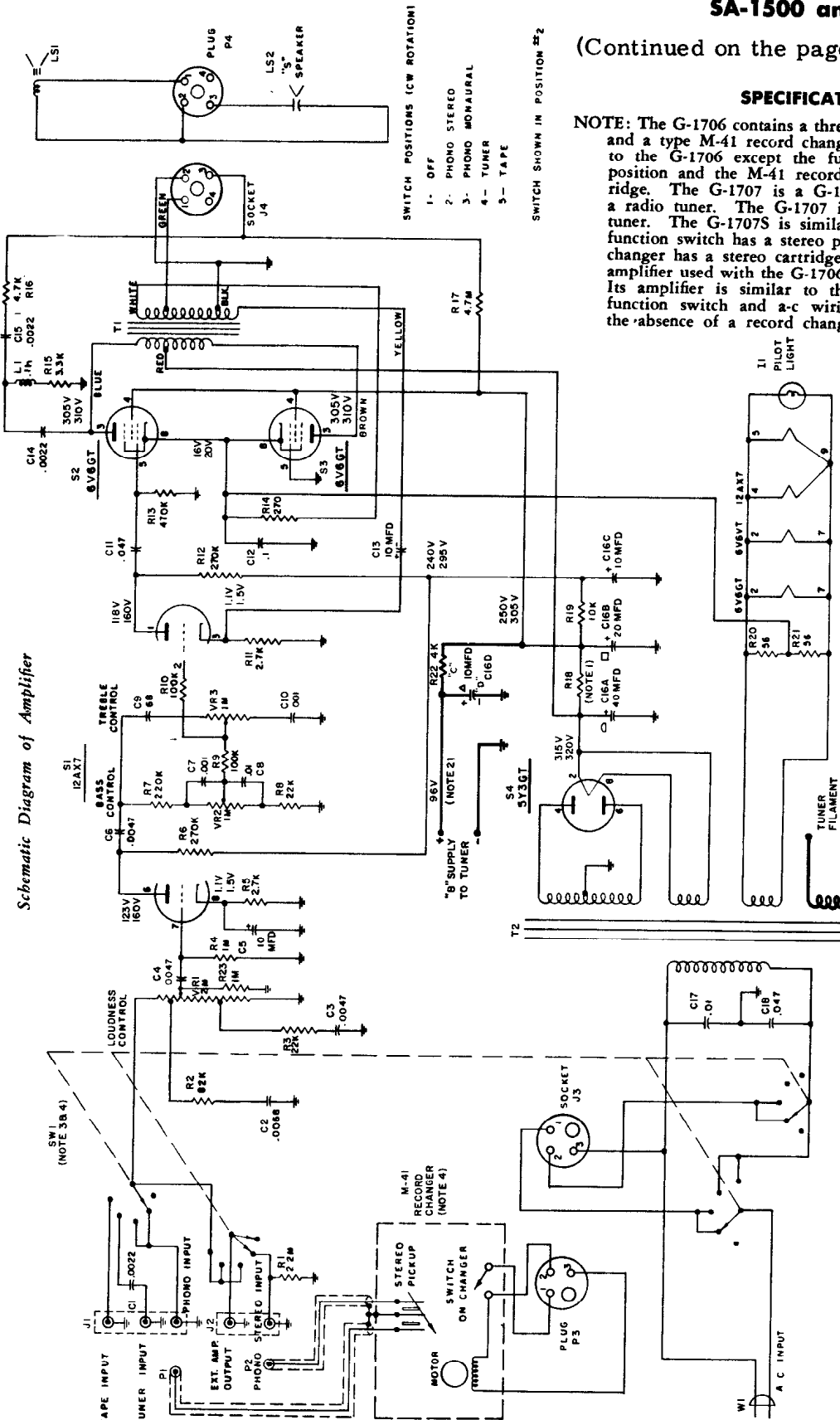

PRODUCTION CHANGE

In later models, C7, C8, C9, C10, R7 and R8 of the amplifier are replaced by network, Philco part no. 58-1893. The physical location of C4 and R10 are changed to accommodate the network.

Circuit — Three-tube audio amplifier plus a rectifier. The amplifier includes bass, treble and loudness controls and a selector switch. Inputs are provided for phono stereo, (G-1706S and G-1707S only) phono monaural, tuner and tape recorder. Models G-1707 and G-1707S use the RT-150 AM-FM tuner. This tuner contains a six-tube superheterodyne circuit. Its operating voltages, B+ and filament, are supplied by the amplifier.

NOTES

1. In models G-1706, G-1706S and SA-1500, R18 is 3.3K. In models G-1707 and G-1707S, R18 is 1.5K.
2. Used in models G-1707 and G-1707S only.
3. Models G-1706 and G-1707 do not have the stereo provision. These models differ from the schematic in that the function switch has positions for OFF, PHONO, TAPE and TUNER. J2 and R1 are not required in these models.
4. Model SA-1500 does not have a record changer or selector switch with positions for OFF, MAIN, J2, 1 and AUX 2.
5. Voltage measurements are taken with a VTVM under no-signal conditions. Wave for each test point, the upper one is for the G-1707 and G-1707S, the lower one is for the remaining models.

PHILCO HI-FIDELITY PHONOGRAPHS

MODELS G-1706, G-1706S, G-1707, G-1707S, SA-1500 and RT-150

(Continued from the page adjacent at left.)

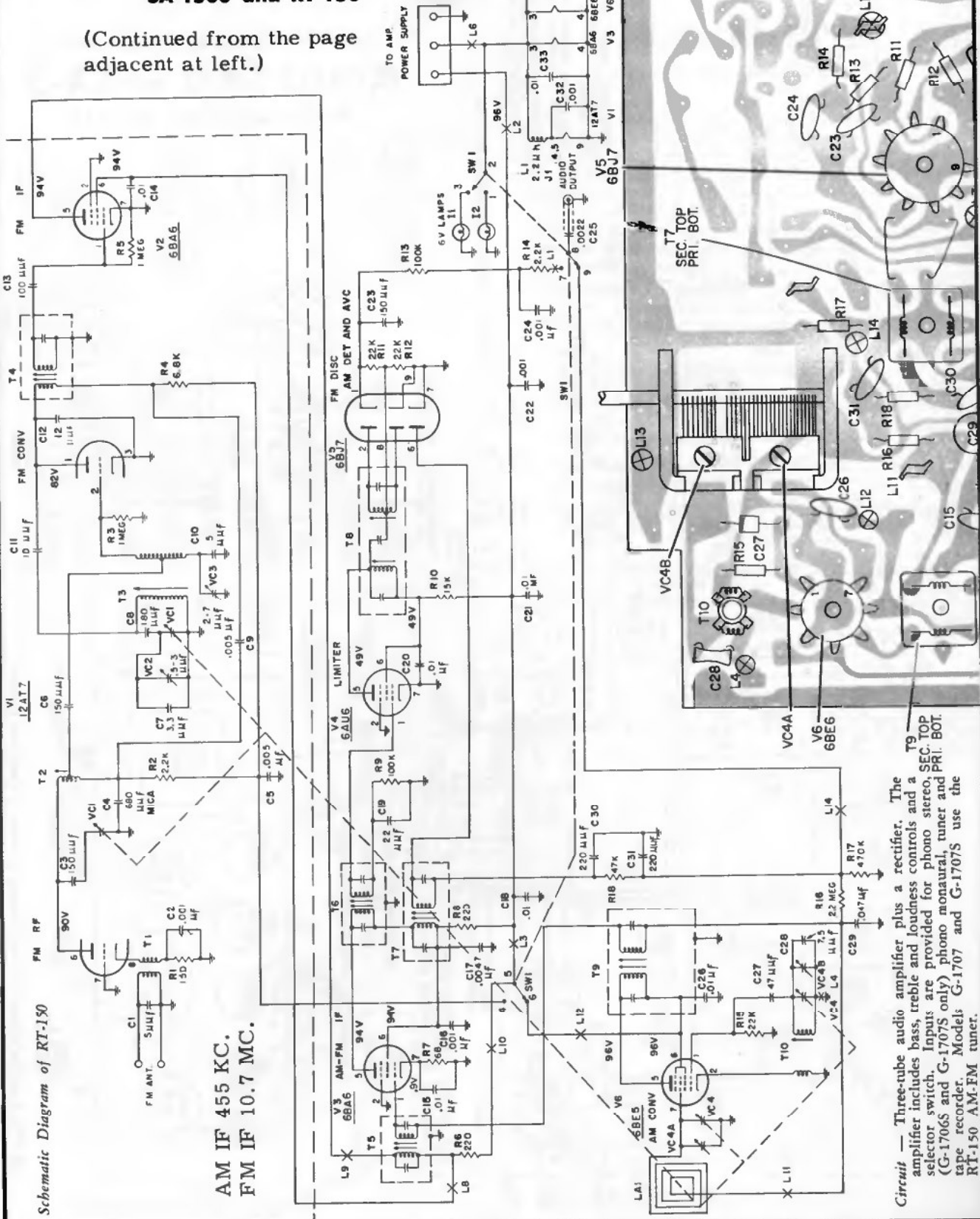

Schematic Diagram of RT-150

AM IF 455 KC.
FM IF 10.7 MC.

Circuit — Three-tube audio amplifier plus a rectifier. The amplifier includes bass, treble and loudness controls and a selector switch. Inputs are provided for phono stereo, SEC. TOP (G-1706S and G-1707S only) phono monaural, tuner and tape recorder. Models G-1707 and G-1707S use the RT-150 AM-FM tuner.

Part of printed wiring panel of RT-150



Amplifier/Speaker Combination

MODELS SA-2 and SA-3

Amp. Chassis No. RS-151B

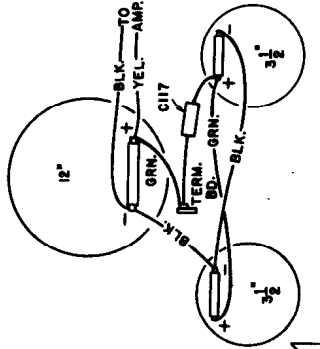

RESISTANCE VALUES IN OHMS. K=1000
CAPACITANCE VALUES LESS THAN 1, IN
MF. 1 AND ABOVE IN MMF. UNLESS OTHER-
WISE NOTED.
DIRECTION OF ARROWS AT CONTROLS
INDICATES CLOCKWISE ROTATION.
VOLTS MEASURED WITH 1/2 VOLT,
OHM/ST. WITH FUNCTION SW. S1 IN
A-M RADIO POSITION; AND SHOULD HOLD
WITHIN ±20% WITH 117 V. A.C. SUPPLY.

Schematic Diagram of Amplifier RS-151B

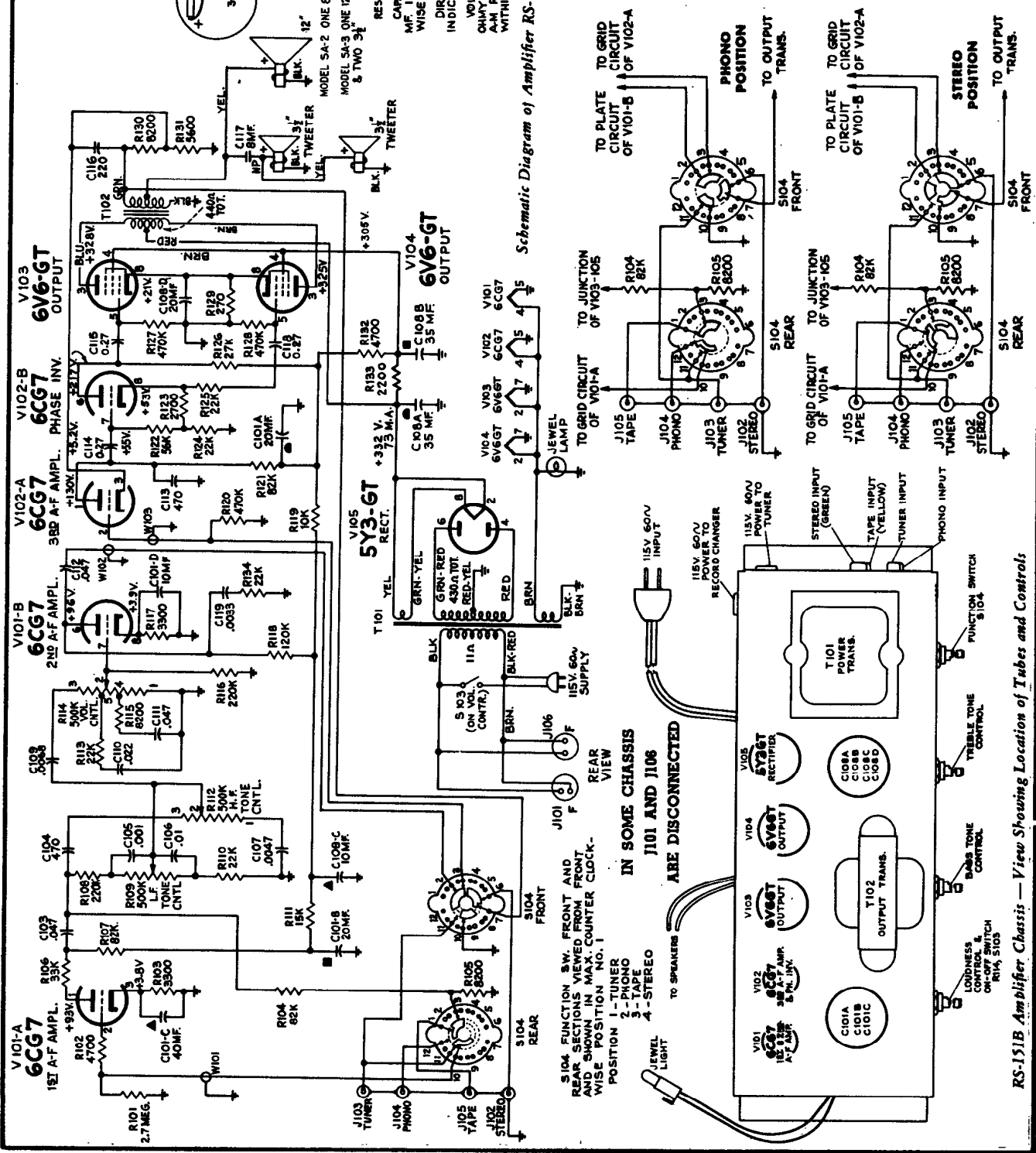

S104 FUNCTION SW. FRONT AND
REAR SECTIONS VIEWED FROM FRONT
AND REAR POSITION IN MAX. COUNTER CLOCK-
WISE POSITION (NO. 1)
POSITION 1-TUNER
2-PHONO
3-TAPE
4-STEREO
TO SPEAKERS

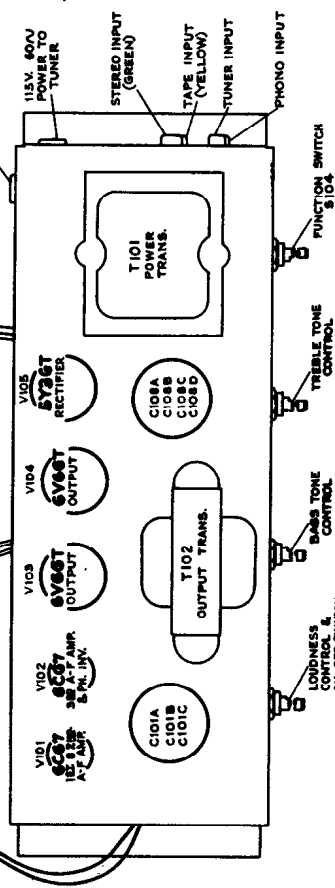

RS-151B Amplifier Chassis — View Showing Location of Tubes and Controls

Simplified Schematic Diagrams of Function Switch in Amplifier Chassis RS-151B



RCA VICTOR

MODEL HF-99

Chassis No. RS-157D

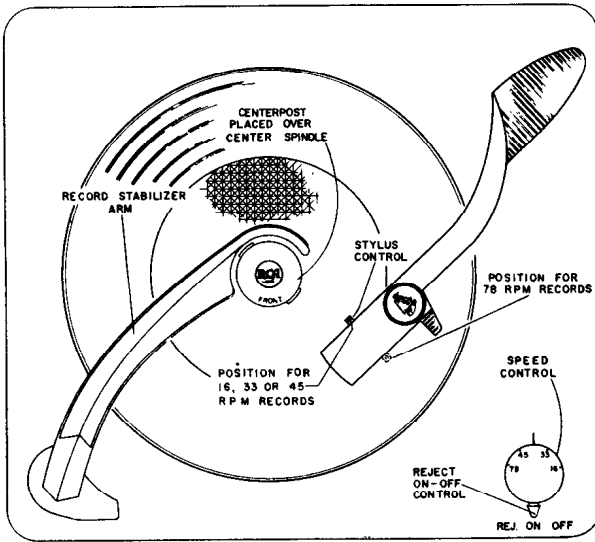

Record Changer Controls

The record changer has a dual control on the motorboard and a stylus selector control on the pickup arm. The metal lever of the dual control is the OFF-ON-REJECT control. Turning this lever to the center position energizes the motor and starts the turntable; when turned to the clockwise position it starts the mechanism into complete automatic operation. The mechanism will shut off automatically after the last record has been played but can be shut off manually by turning this lever counter-clockwise.

The circular knob of the dual control is the speed control. It has four positions: "16", "33", "45", "78", to select the turntable speed desired and a neutral ("N") position.

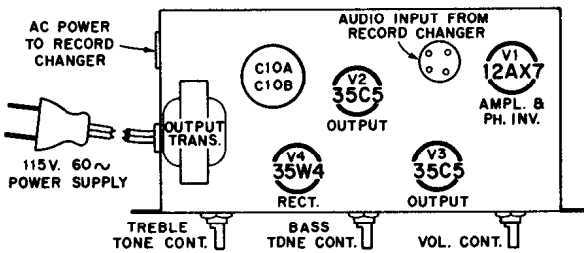

View of Amplifier Chassis Showing Location of Tubes and Major Components

CRITICAL LEAD DRESS

1. Dress all heater leads and power cord close to chassis and away from 12AX7 tube socket and phono input jack to maintain low hum level.
2. Keep shielded lead W1, including shield connections, as short as possible.
3. Dress record changer power cable and pickup cable as far apart as possible to minimize hum pickup.

NOTE—The "ON-OFF" switch is not part of the volume control. The record changer must be "ON" for power to be applied to the amplifier.

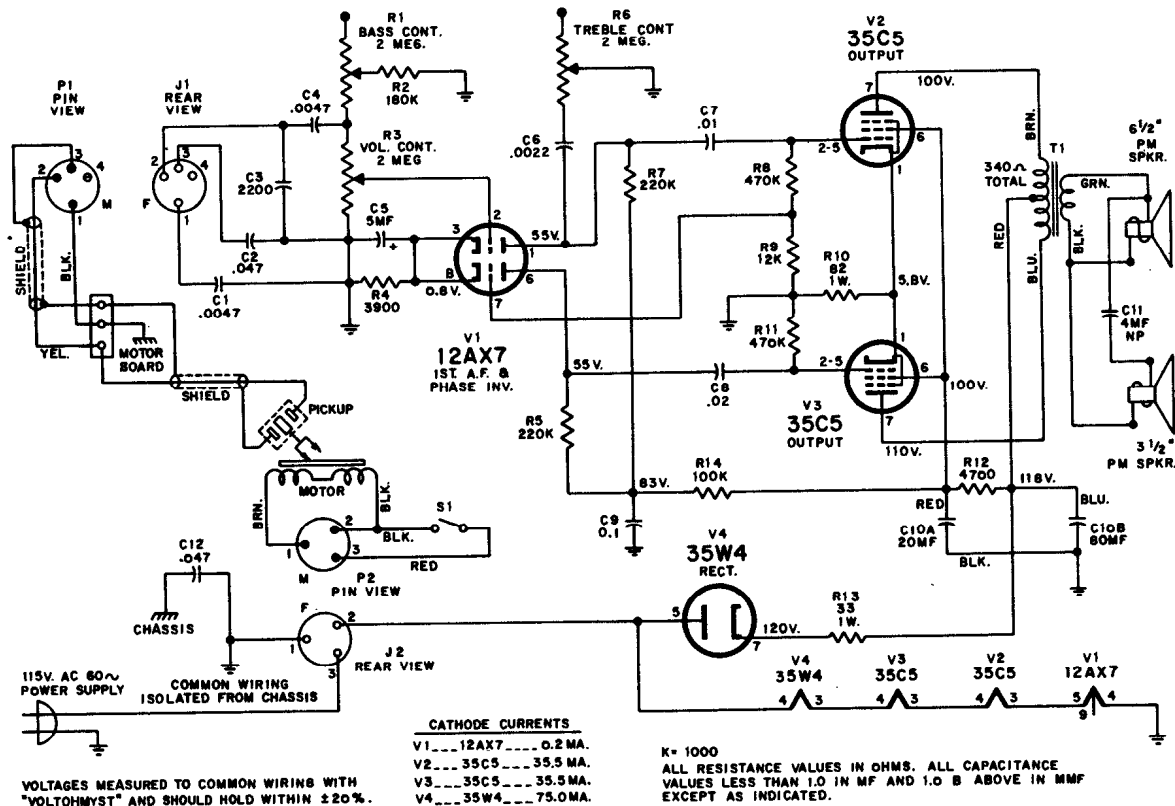



SHP-11 STEREO RECORD PLAYER
Chassis RS-171A

SHS-11 SPEAKER CABINET

TO EXTERNAL SPEAKERS FOR LEFT CHANNEL

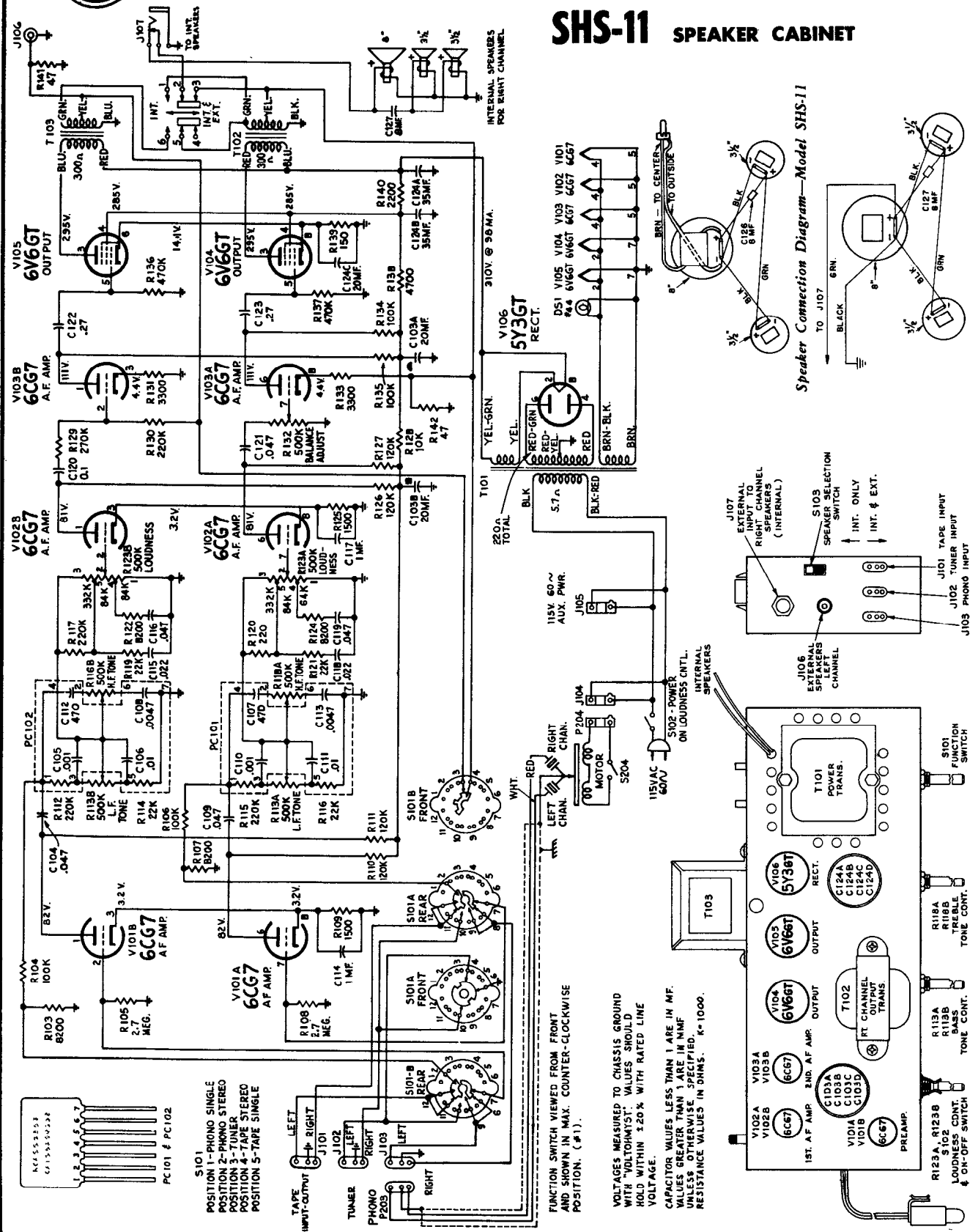

Speaker Connection Diagram—Model SHS-11

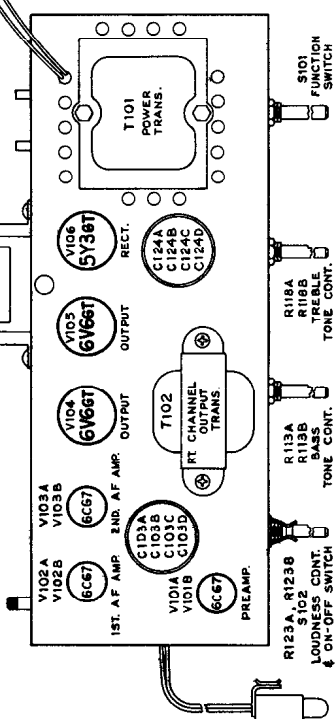
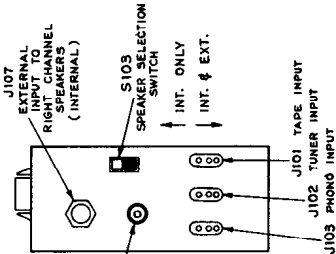
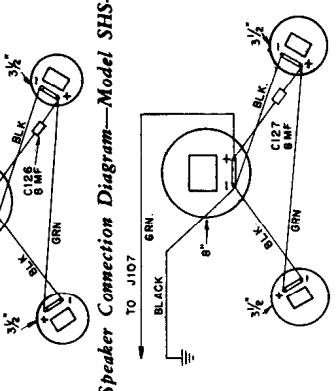

S101
POSITION 1—PHONO SINGLE
POSITION 2—PHONO STEREO
POSITION 3—TUNER
POSITION 4—TAPE STEREO
POSITION 5—TAPE SINGLE

TAPE INPUT-OUTPUT
TUNER PHONO

FUNCTION SWITCH VIEWED FROM FRONT AND SHOWN IN MAX. COUNTER-CLOCKWISE POSITION. (#1).

VOLTAGES MEASURED TO CHASSIS GROUND WITH VOLTOHMIST. VALUES SHOULD HOLD WITHIN 120% WITH RATED LINE VOLTAGE.
CAPACITOR VALUES LESS THAN 1 ARE IN MF. VALUES GREATER THAN 1 ARE IN MMF UNLESS OTHERWISE SPECIFIED.
RESISTANCE VALUES IN OHMS. K=1000.

RCA VICTOR

MODELS SHP-12, SHP-13, TYPE AK-1

Chassis No. RS-172

ACCESS TO TUBES AND CHASSIS

Model SHP-12

Turn cabinet on its side and remove ten wood screws holding the bottom cover to the cabinet.

Model SHP-13

Remove inside front panel held by screws. Remove control knobs. Remove screws at edges of record changer mounting board; tilt board upward.

CRITICAL LEAD DRESS

Dress heater leads close to chassis. Dress all leads away from phono input socket. Keep leads of C4 and C7 as short as possible and dress all other components away from these capacitors. Record changer motor leads must be twisted to minimize hum.

NOTE—The "ON-OFF" switch is not part of the volume control. The record changer must be "ON" for power to be applied to the amplifier.

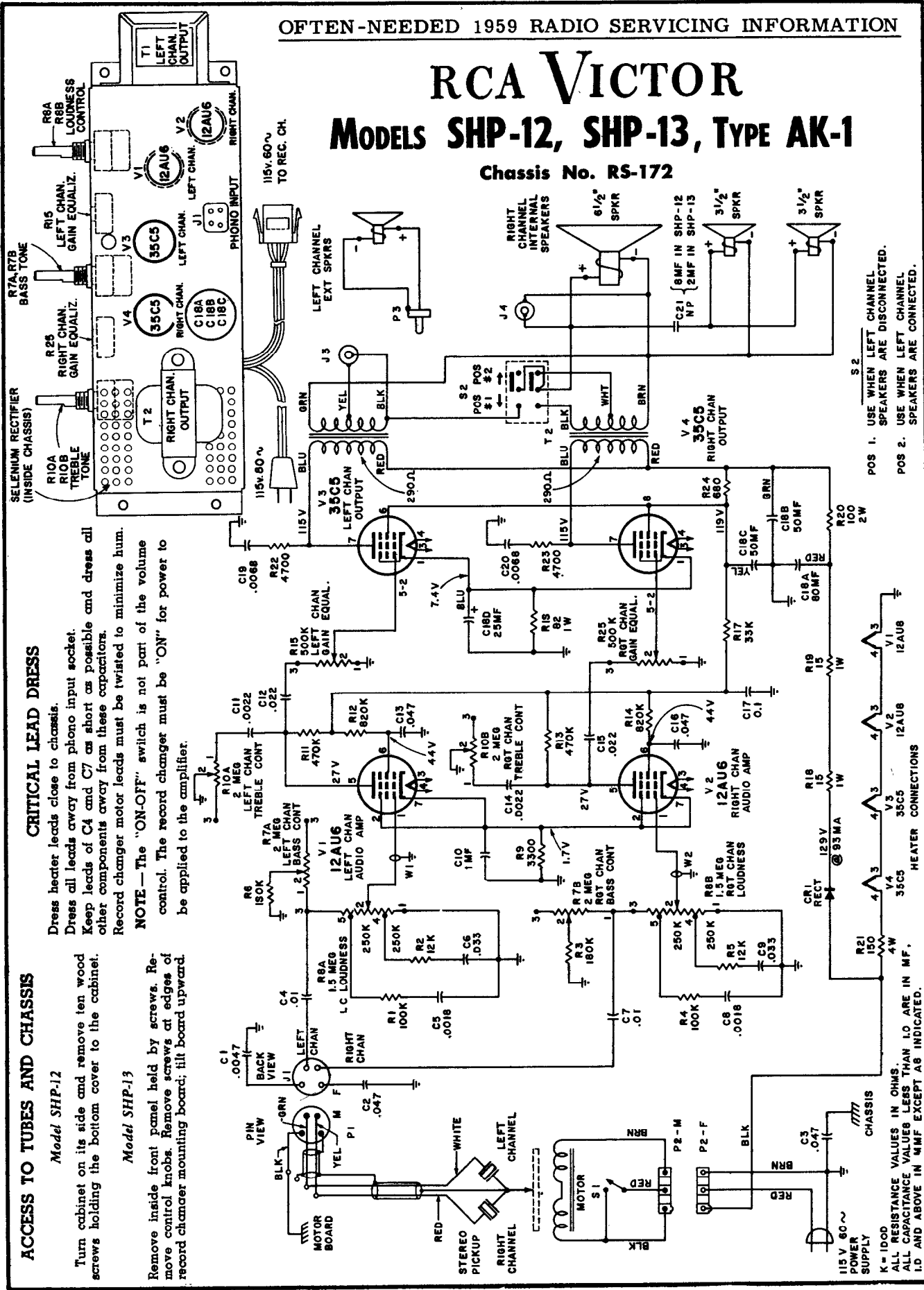

POS 1. USE WHEN LEFT CHANNEL SPEAKERS ARE DISCONNECTED.
 POS 2. USE WHEN LEFT CHANNEL SPEAKERS ARE CONNECTED.

HEATER CONNECTIONS
 V1 12AU6
 V2 12AU6
 V3 35C5
 V4 35C5

RESISTANCE VALUES IN OHMS.
 ALL CAPACITANCE VALUES LESS THAN 10 ARE IN MF.
 1.0 AND ABOVE IN MMF EXCEPT AS INDICATED.



RCA VICTOR

MODEL SES-6

Chassis No. RS-175

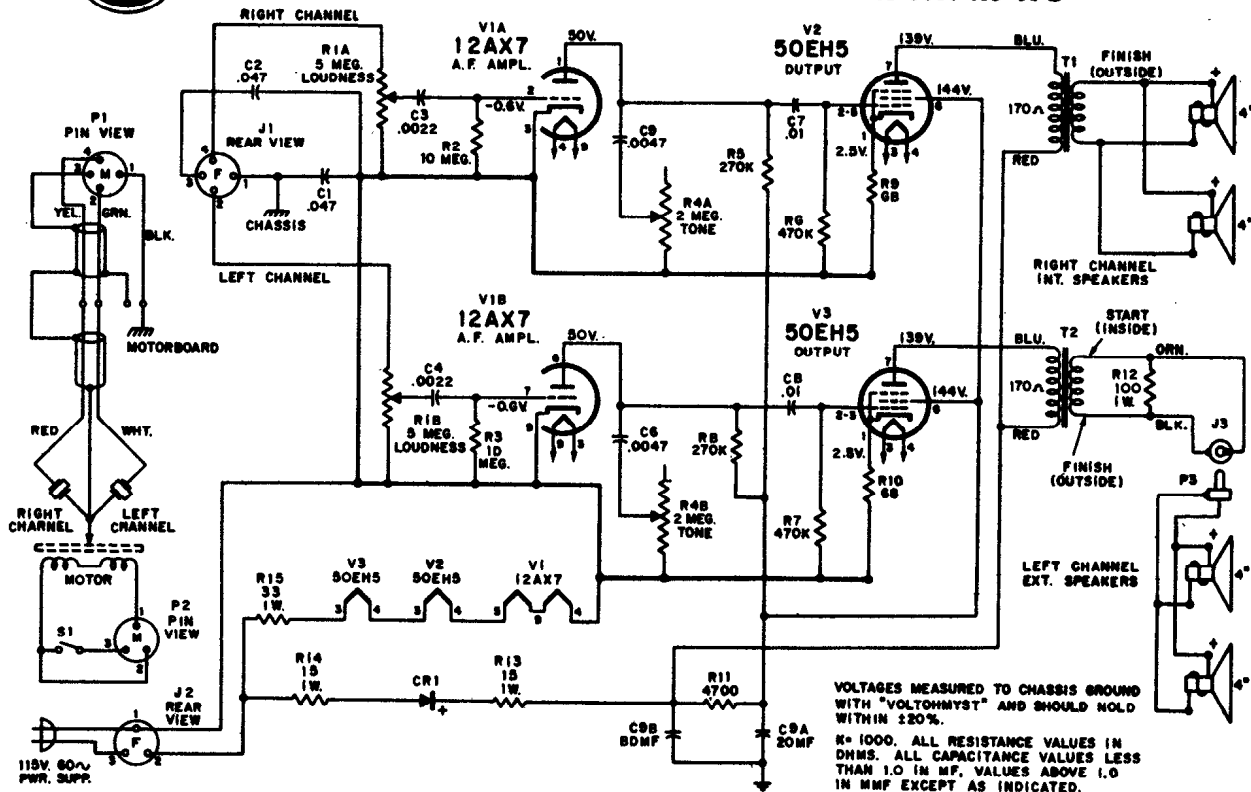

VOLTAGES MEASURED TO CHASSIS GROUND WITH "VOLTOHMYST" AND SHOULD HOLD WITHIN 120%.
 R = 1000. ALL RESISTANCE VALUES IN OHMS. ALL CAPACITANCE VALUES LESS THAN 1.0 IN MF. VALUES ABOVE 1.0 IN MMF EXCEPT AS INDICATED.

SPEAKER PHASING

The two speaker systems must be properly connected in order to have in-phase sound outputs. Incorrect connections will be evidenced by a "null point" in the sound when playing

a monaural record and listening from a point midway between the two speaker systems. For the same reason both speakers in each system should be phased with each other.

REPLACEMENT PARTS

| Symbol No. | Stock No. | Description | Symbol No. | No. Stock | Description |
|---|-----------|---|------------------------------|-----------|--|
| AMPLIFIER ASSEMBLY RS-175 | | | RECORD CHANGER WIRING | | |
| CAPACITORS: | | | P1 | 101748 | Connector—4-contact male for pickup cable |
| C1, C2 | 73553 | paper, 0.047 ml., +100-0%, 400 v. | P2 | 101747 | Connector—3-contact male for motor cable |
| C3, C4 | 77953 | ceramic, 0.0022 ml., ±20%, 500 v. | | 101825 | Connector—Closed end, for motor lead |
| C5, C6 | 103905 | ceramic, 0.0047 ml., ±20%, 1000 v. | | 76301 | Switch—"ON-OFF" power switch |
| C7, C8 | 73960 | ceramic, 0.01 ml., +100-0%, 500 v. | SPEAKER ASSEMBLY | | |
| C9A, C9B | 101752 | electrolytic, 80/20 ml., 150/150 v. | | 31048 | Connector—Single contact male for remote speaker cable |
| CR1 | 106967 | Rectifier—Silicon | | 79696-A | Speaker—4" PM |
| J1 | 101749 | Connector—4-contact female with retainer for pickup cable | | | |
| J2 | 101750 | Connector—3-contact female with retainer for motor-cable | | | |
| RESISTORS: | | | | | |
| Fixed, Composition, unless otherwise specified: | | | | | |
| R1A, R1B | 106969 | Control—Dual volume | | | |
| R2, R3 | | 10 megohm, ±20%, ½ w. | | | |
| R4A, R4B | 106968 | Control—Dual tone | | | |
| R5 | | 270,000 ohm, ±10%, ½ w. | | | |
| R6, R7 | | 470,000 ohm, ±20%, ½ w. | | | |
| R8 | | 270,000 ohm, ±10%, ½ w. | | | |
| R9, R10 | | 68 ohm, ±10%, ½ w. | | | |
| R11 | | 4700 ohm, ±20%, ½ w. | | | |
| R12 | | 100 ohm, ±20%, 1 w. | | | |
| R13, R14 | | 15 ohm, ±20%, 1 w. | | | |
| R15 | | 33 ohm, ±20%, 1 w. | | | |
| T1, T2 | 100272 | Transformer—Output | | | |
| | 70392 | Cable—AC power cable with plug | | | |
| | 74822 | Socket—7-pin miniature for V2 and V3 | | | |
| | 79799 | Socket—9-pin miniature for V1 | | | |

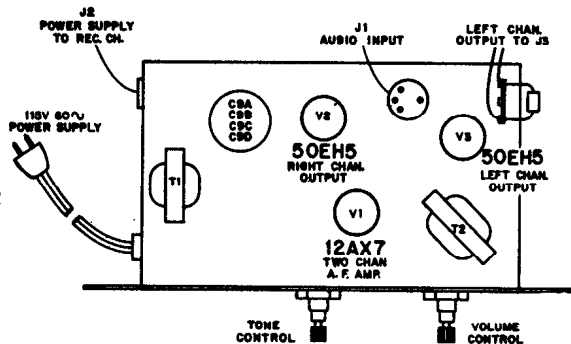

View of Chassis Showing Location of Tubes and Major Components

RCA VICTOR MODEL SHP-14

Chassis No. RS-175A

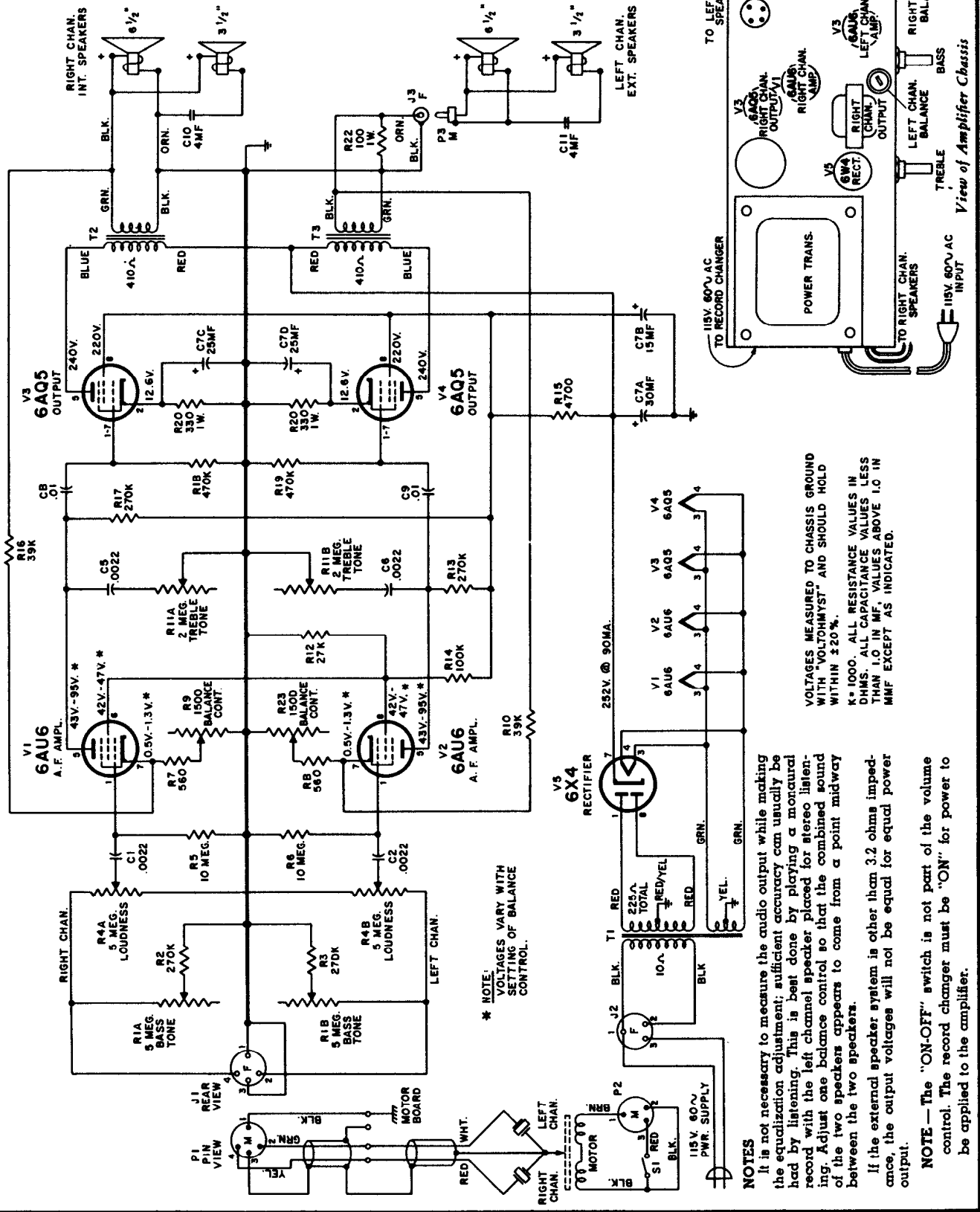

RCA Victor Model 1-BT-3, Chassis RC-1187A

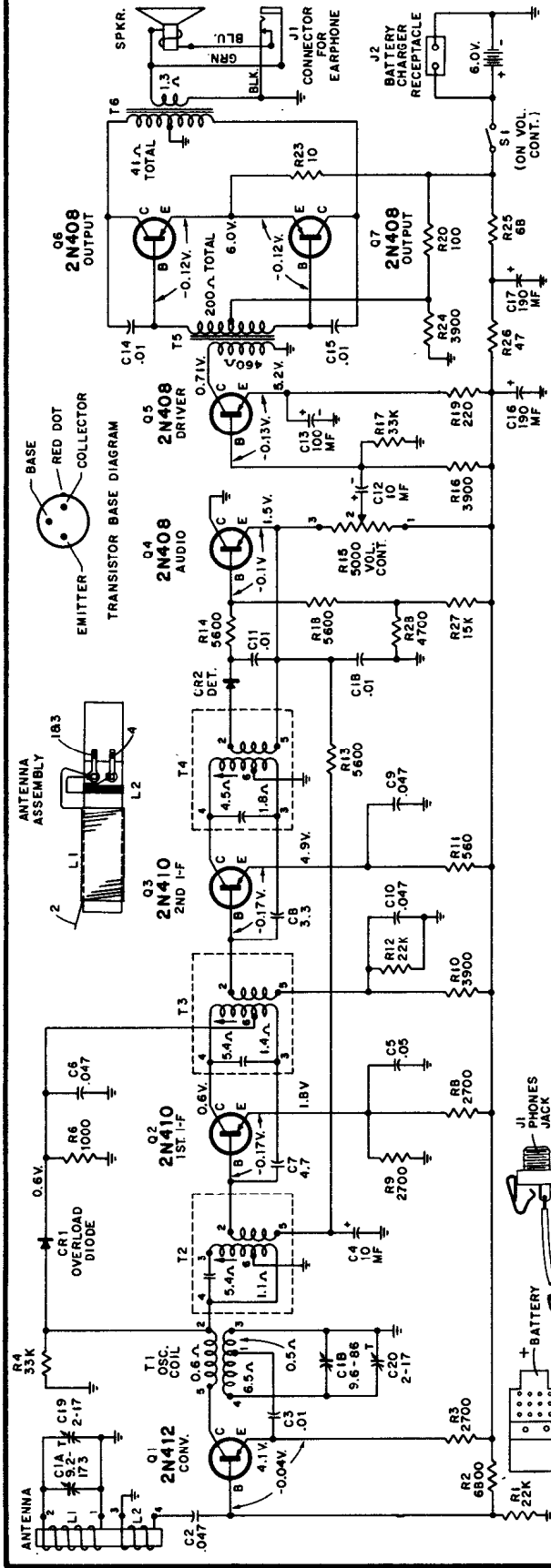

VOLTAGES MEASURED WITH "VOLTOMYST" SHOULD HOLD WITHIN 120% WITH NEW BATTERY. K=1000. ALL RESISTANCE VALUES IN OHMS. ALL CAPACITANCE VALUES LESS THAN 1.0 IN MF AND 1.0 & ABOVE IN MMF EXCEPT THOSE INDICATED.

EMITTER CURRENTS WITH 6.0V. BATTERY AND NO SIGNAL INPUT

| | |
|----|--------|
| Q1 | 0.5 MA |
| Q2 | 0.6 MA |
| Q3 | 1.0 MA |
| Q4 | 0.7 MA |
| Q5 | 1.5 MA |
| Q6 | 2.5 MA |
| Q7 | 2.5 MA |

TOTAL BATTERY CURRENT

| CURRENT | OUTPUT |
|---------|--------|
| B.8 MA | 0 |
| 22 MA | 20 MW |
| 29 MA | 50 MW |
| 43 MA | MAX. |

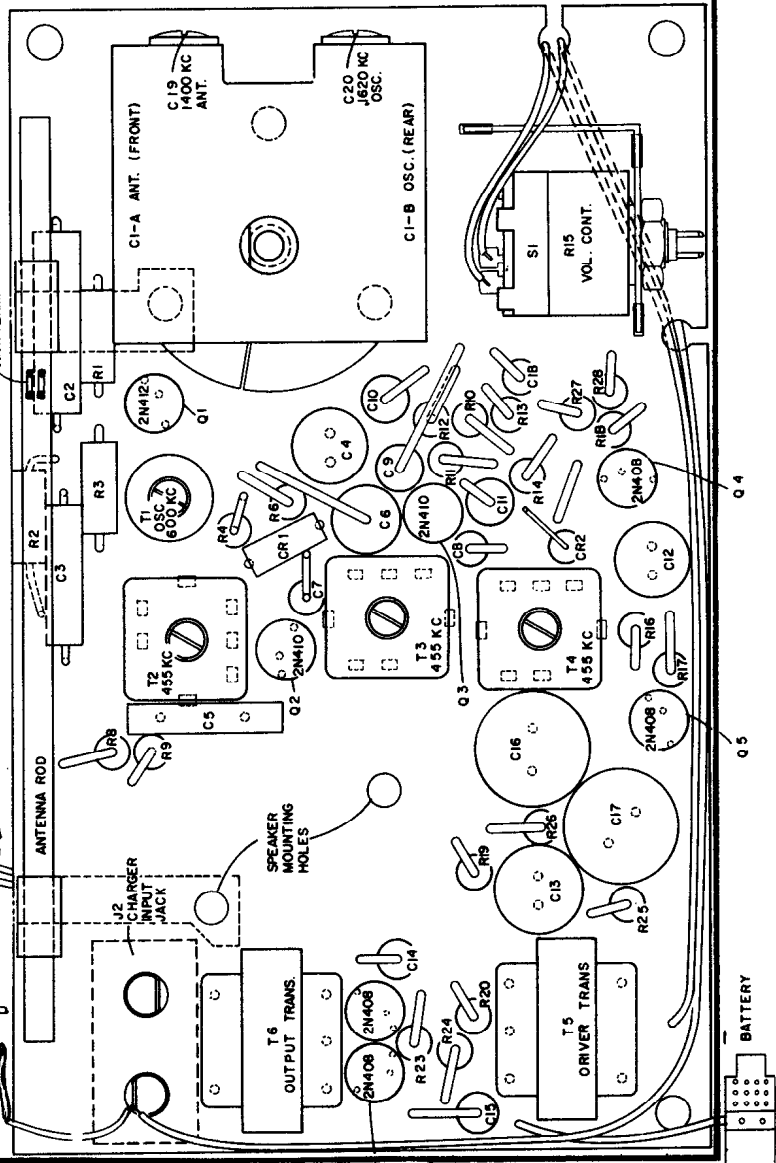
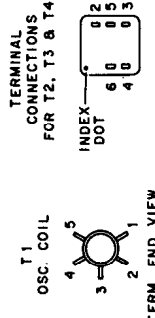

RCA VICTOR

MODEL 1-BT-3 Series

Chassis No. RC-1187A

RCA VICTOR

AC-DC Radio Receiver X-1, X-2 SERIES Chassis No. RC-1188

C-1 Series, Chassis RC-1188A, is almost identical except for clock timer with its switch circuit.

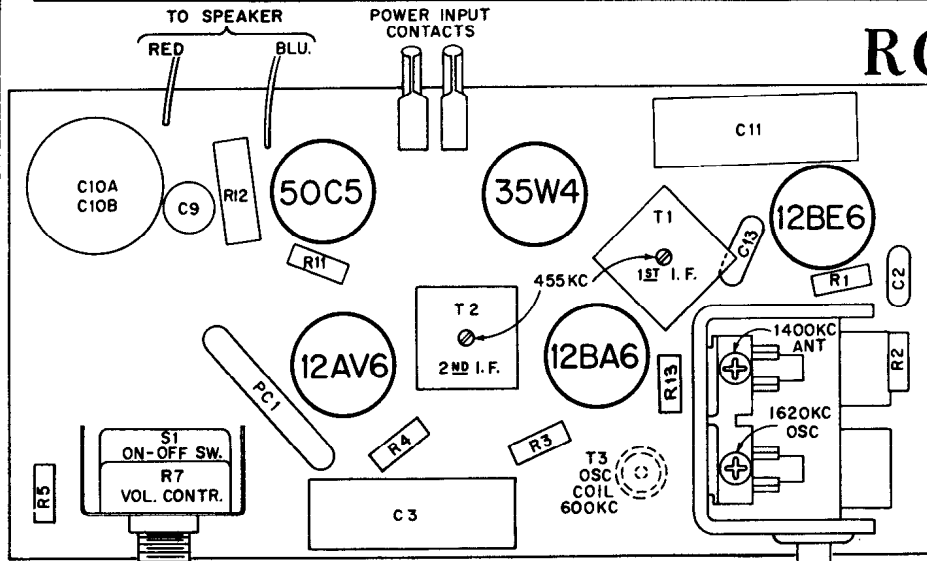

Tube and Trimmer Locations

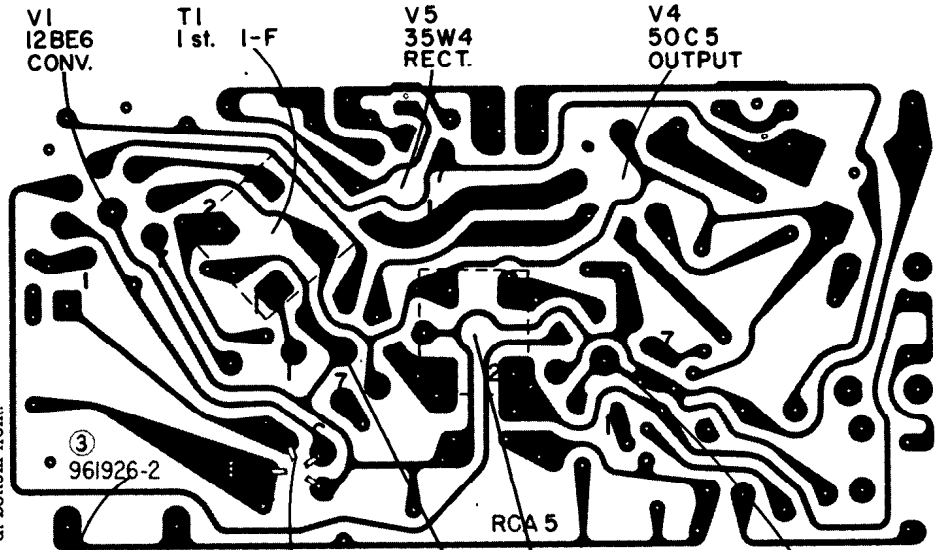

Chassis Wiring and Components — View from Wiring Side

CHASSIS REMOVAL

1. Remove three cabinet holding screws; two at back of top lip and one at bottom front.
2. Grip cabinet with two hands allowing fingers to extend over edges of cabinet front.
3. Hold cabinet, front down, and shake in a vertical direction. Cabinet assembly will separate and the fingers will limit the separation.
4. The cabinet front and chassis assembly may now be separated completely.

CABINET REASSEMBLY

1. Place chassis front and chassis assembly on the cabinet back so that the ribs of the cabinet front rest on the bottom — inside of the cabinet back.
2. Push cabinet sections together firmly.
3. Insert three holding screws; two at back of top lip and one at bottom front.

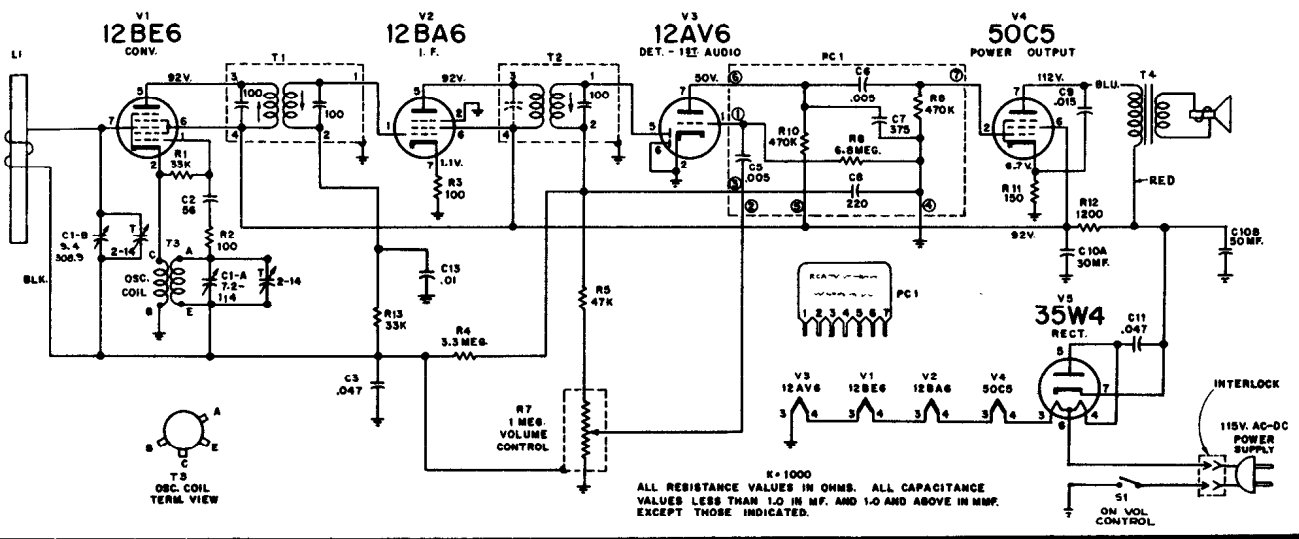

K = 1000
ALL RESISTANCE VALUES IN OHMS. ALL CAPACITANCE VALUES LESS THAN 1.0 IN MF. AND 1.0 AND ABOVE IN MMF. EXCEPT THOSE INDICATED.

Roland

MODEL 71-483

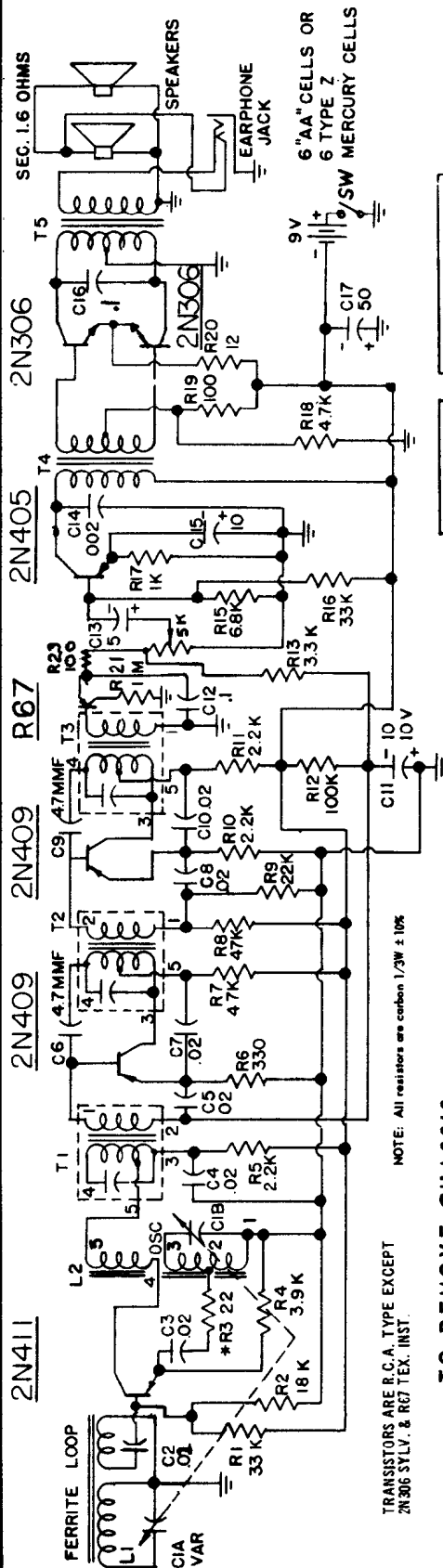

TRANSISTORS ARE R.C.A. TYPE EXCEPT 2N306 SYLV. & R67 TEX. INST.

NOTE: All resistors are carbon 1/2W ± 10%

TO REMOVE CHASSIS

1. Remove volume control knob by pulling away from case.
2. Move handle to rear.
3. Release spring clips on each side of cabinet and remove back.
4. Remove battery holder.
5. Unscrew the four chassis corner mounting screws
6. Remove one screw holding volume control bracket.
7. Slide down to bottom of case and out to clear tuning knob from case.

* INSTALLED IN SOME SETS AT FACTORY

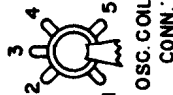

ALIGNMENT

| Function | Generator Frequency | Dummy Antenna Conn. | Generator Antenna Conn. | Adjust for Max. Output | Remarks |
|-----------------|---------------------|---|-------------------------|--|------------|
| 1. I.F. | 455KC | .1 Mfd Condenser in series with Gen. Lead | Base | On Converter | T1, T2, T3 |
| 2. Osc. Trimmer | 1620KC | * Test Loop | C1-B | Variable Condenser Set for Minimum capacity | |
| 3. Osc. Slug | 540KC | * Test Loop | L-2 Slug | Variable Condenser Set For Maximum Capacity ² | |
| 4. Ant. Trimmer | 1400KC | * Test Loop | C1-A | Tune 1400 Kc on Variable Condenser | |

* Standard Hozeltine Loop Model 1150 or 3 turns of wire about 6" diameter placed one foot from set.

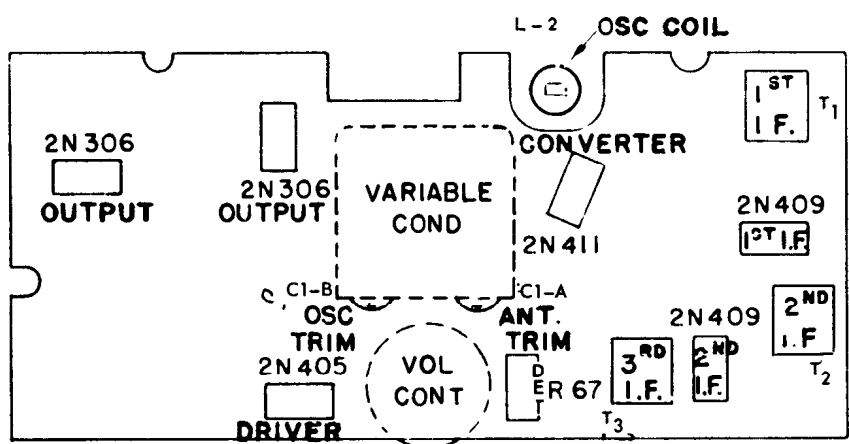

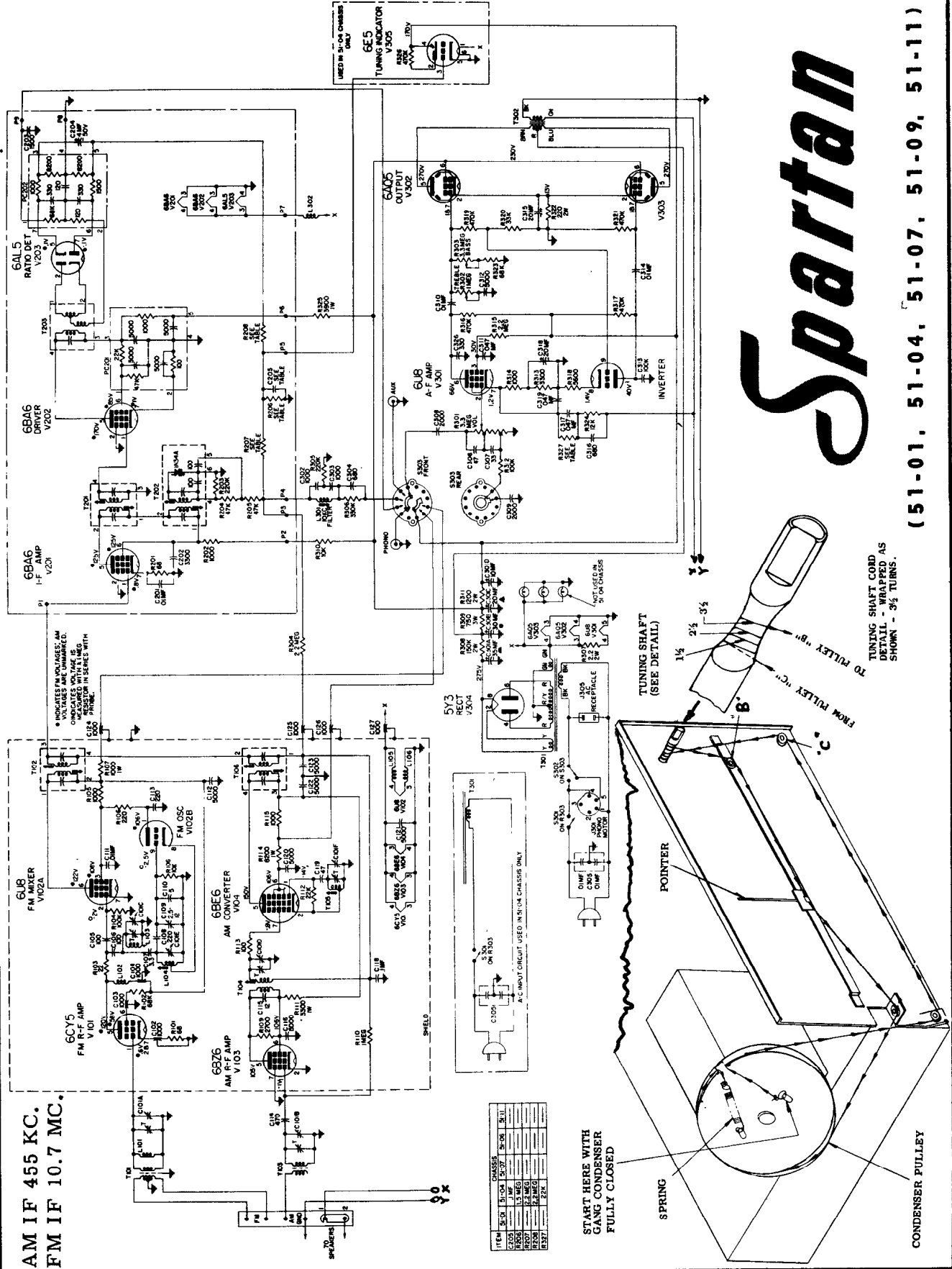

AM IF 455 KC.
FM IF 10.7 MC.

| ITEM | SIZE | CHASSIS | 51-04 | 51-07 | 51-08 | 51-11 |
|------|-------|---------|-------|-------|-------|-------|
| 1174 | 51-04 | 51-04 | 51-07 | 51-08 | 51-11 | |
| 1175 | 51-04 | 51-04 | 51-07 | 51-08 | 51-11 | |
| 1176 | 51-04 | 51-04 | 51-07 | 51-08 | 51-11 | |
| 1177 | 51-04 | 51-04 | 51-07 | 51-08 | 51-11 | |
| 1178 | 51-04 | 51-04 | 51-07 | 51-08 | 51-11 | |
| 1179 | 51-04 | 51-04 | 51-07 | 51-08 | 51-11 | |
| 1180 | 51-04 | 51-04 | 51-07 | 51-08 | 51-11 | |
| 1181 | 51-04 | 51-04 | 51-07 | 51-08 | 51-11 | |
| 1182 | 51-04 | 51-04 | 51-07 | 51-08 | 51-11 | |
| 1183 | 51-04 | 51-04 | 51-07 | 51-08 | 51-11 | |
| 1184 | 51-04 | 51-04 | 51-07 | 51-08 | 51-11 | |
| 1185 | 51-04 | 51-04 | 51-07 | 51-08 | 51-11 | |
| 1186 | 51-04 | 51-04 | 51-07 | 51-08 | 51-11 | |
| 1187 | 51-04 | 51-04 | 51-07 | 51-08 | 51-11 | |
| 1188 | 51-04 | 51-04 | 51-07 | 51-08 | 51-11 | |
| 1189 | 51-04 | 51-04 | 51-07 | 51-08 | 51-11 | |
| 1190 | 51-04 | 51-04 | 51-07 | 51-08 | 51-11 | |

Spartan

(51-01, 51-04, 51-07, 51-09, 51-11)

SYLVANIA ELECTRIC PRODUCTS

CHASSIS 1-609-7
MODELS: SC03 SERIES

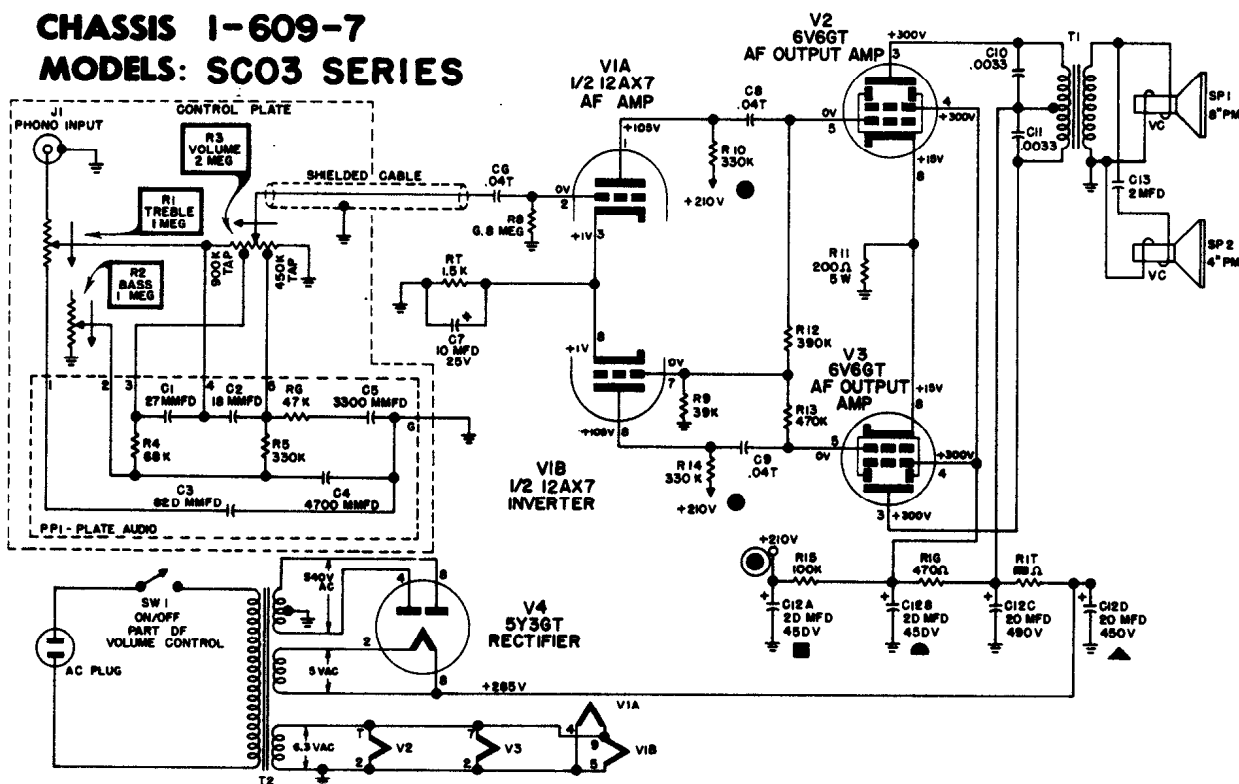

CHASSIS: 1-639-1
MODELS: 4312 SERIES

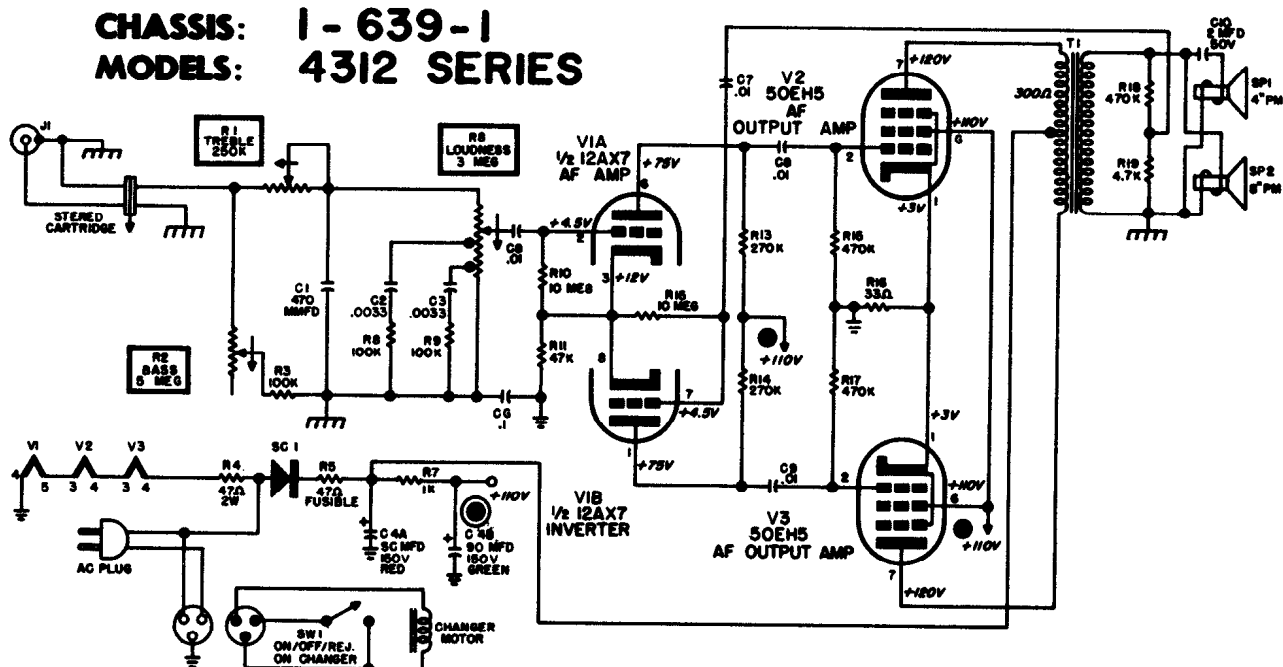

SCHEMATIC NOTES:

1. VOLTAGES SHOWN ARE AVERAGE READINGS MEASURED TO NEGATIVE "B" WITH NO SIGNAL INPUT. VARIATIONS MAY BE NOTED DUE TO NORMAL PRODUCTION TOLERANCES.
2. AC POWER SOURCE - 117V 60W "VARIAC REGULATED".
3. VOLTAGE SOURCE IS INDICATED BY ENCIRCLED SYMBOL (⊙): CORRESPONDING SYMBOL WITHOUT CIRCLE (⊙) INDICATES VOLTAGE TIE POINTS.
4. $\text{---}\text{---}\text{---}$ DESIGNATES CHASSIS GROUND.
5. $\text{---}\text{---}$ DESIGNATES NEGATIVE "B".

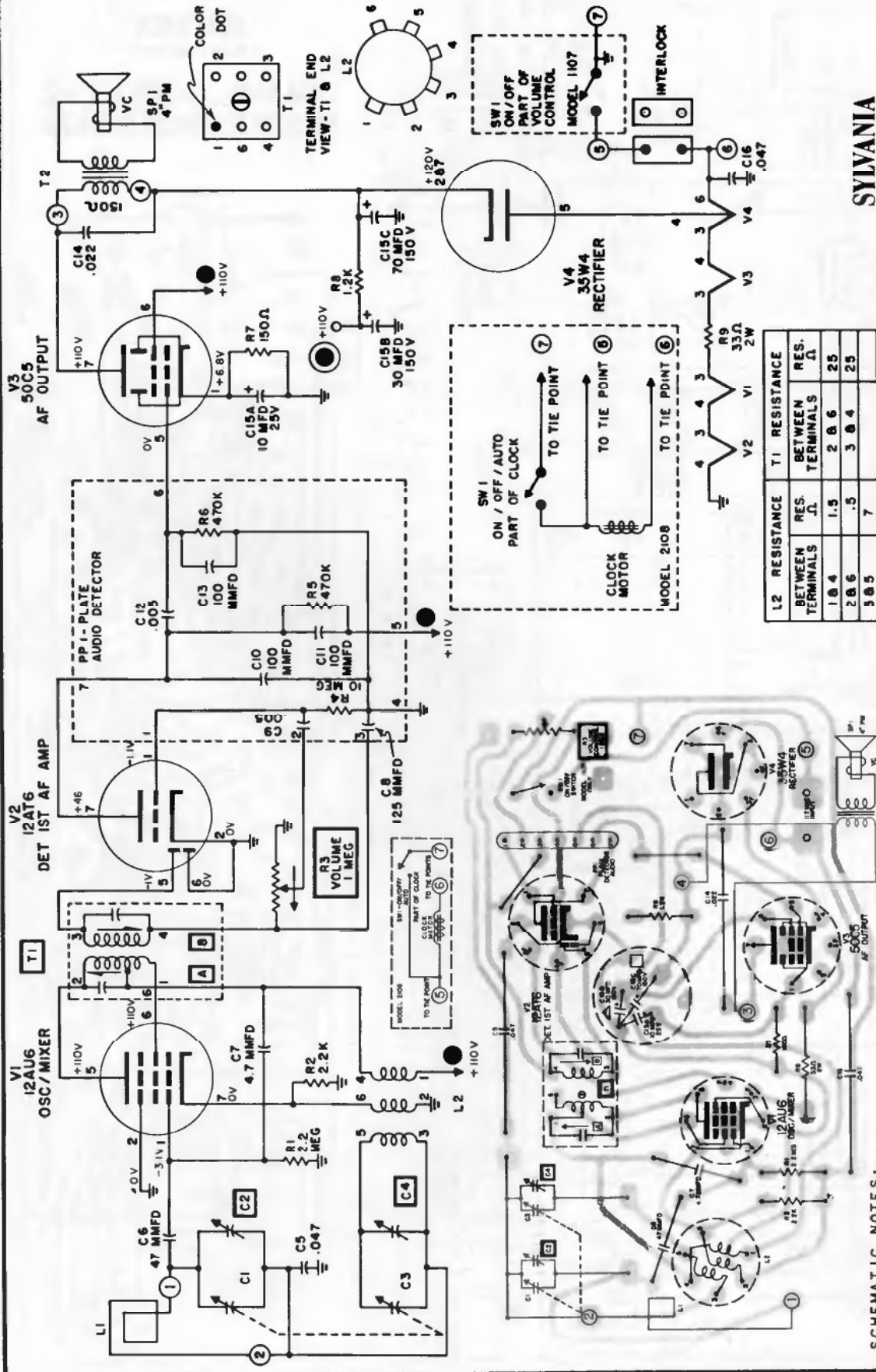

SYLVANIA
RADIO & TELEVISION

CHASSIS: 1-629-1,-2
MODELS: 1107 & 2108

SCHEMATIC NOTES:
COIL AND TRANSFORMER RESISTANCES ARE AVERAGE VALUES AND ARE TAKEN WITH COMPONENT CONNECTED IN THE CIRCUIT.

INTERMEDIATE FREQUENCY 455KC.
ENCIRCLED NUMBERS CORRESPOND WITH TIE POINTS ON PRINTED BOARD.
VOLTAGE SOURCE IS INDICATED BY ENCIRCLED SYMBOL Ⓢ; CORRESPONDING SYMBOL WITHOUT CIRCLE Ⓢ INDICATES VOLTAGE TIE POINTS.
Ⓢ DESIGNATES NEGATIVE "B".

SYLVANIA
RADIO & TELEVISION

CHASSIS: 1-630-1,-2
MODELS: 1108 & 2109

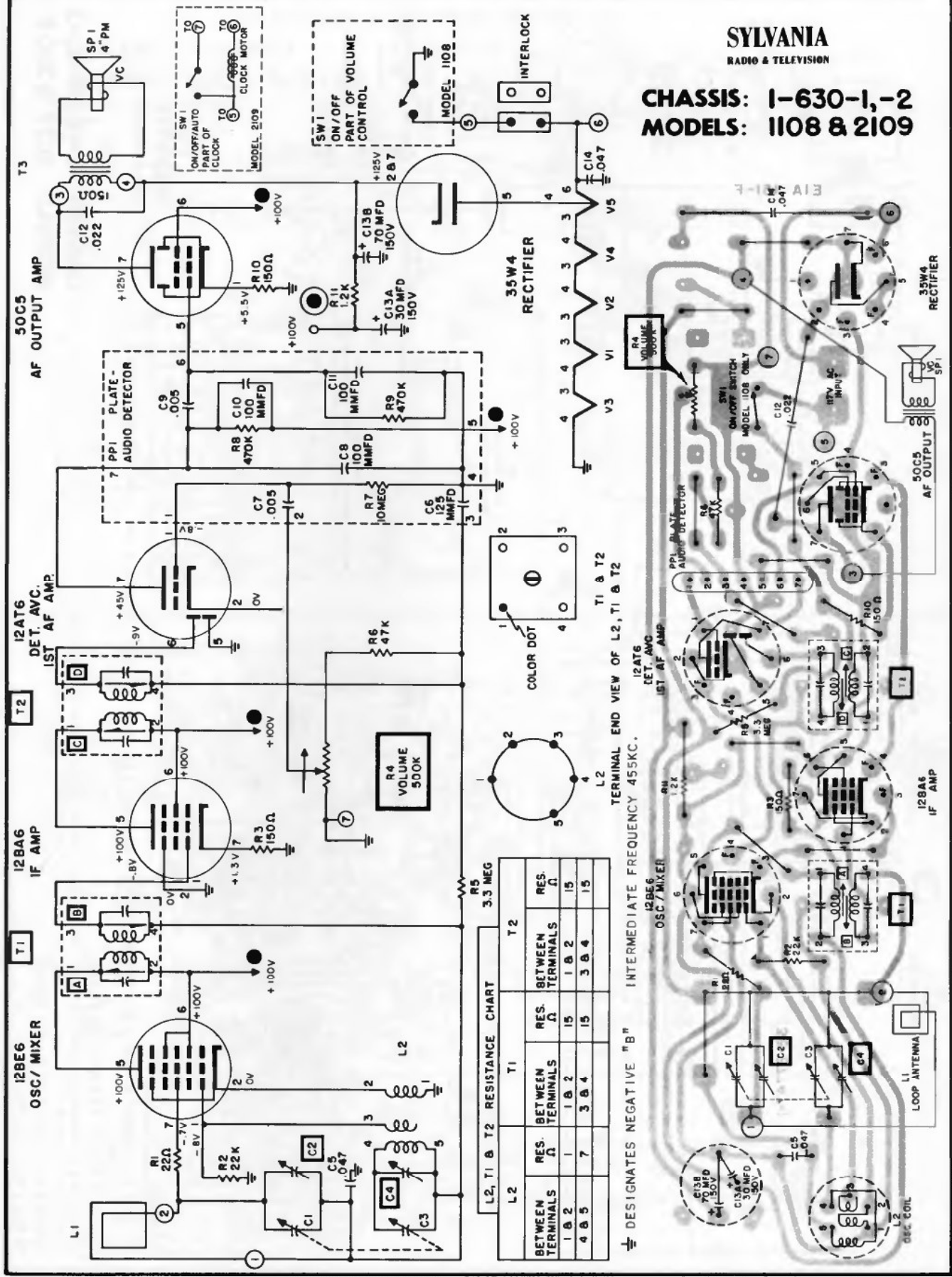

SYLVANIA Electric Products
Chassis 1-631-1, Model 1303

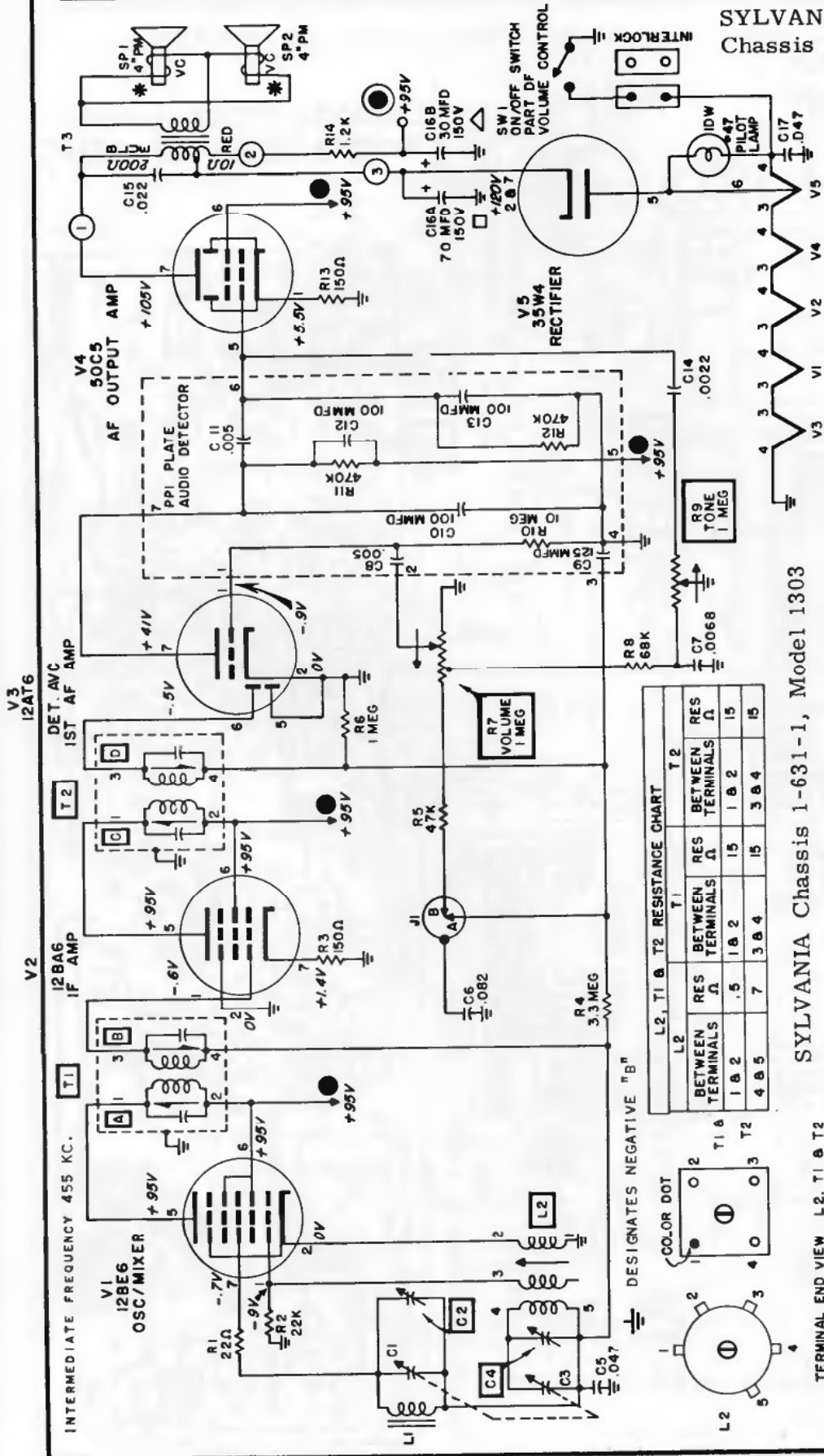

RESISTANCE CHART

| L2 | T1 | T2 | RES BETWEEN TERMINALS | RES BETWEEN TERMINALS |
|-----|-----|-----|-----------------------|-----------------------|
| 1 2 | 1 2 | 1 5 | .5 | 1 2 |
| 4 5 | 7 | 3 4 | 15 | 3 4 |
| | | | 15 | 5 |

DESIGNATES NEGATIVE "B"

SYLVANIA Chassis 1-631-1, Model 1303

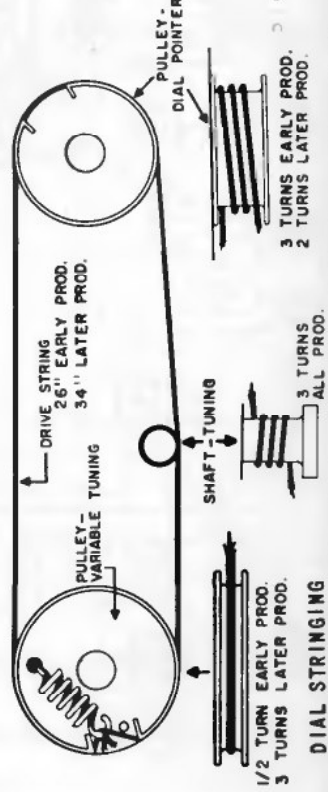
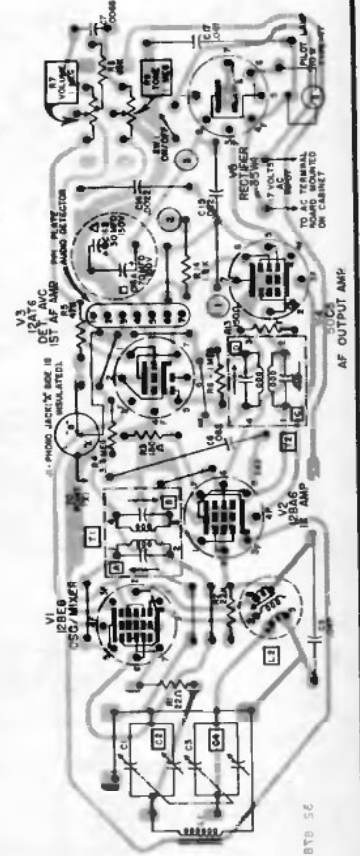

SYLVANIA ELECTRIC PRODUCTS Chassis 1-645-1, Models 4413, 4422

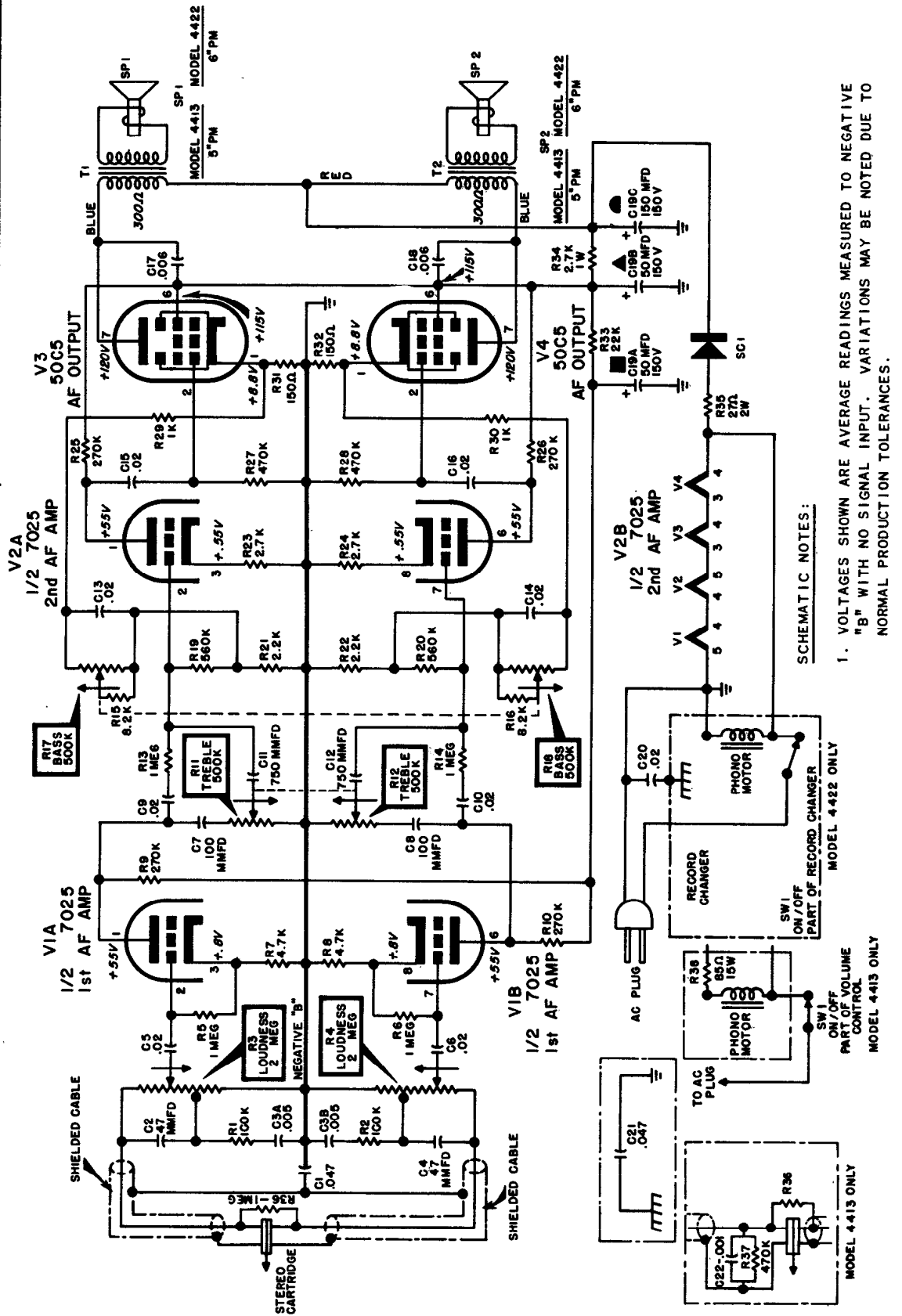

SCHEMATIC NOTES:

1. VOLTAGES SHOWN ARE AVERAGE READINGS MEASURED TO NEGATIVE "B" WITH NO SIGNAL INPUT. VARIATIONS MAY BE NOTED DUE TO NORMAL PRODUCTION TOLERANCES.
2. AC POWER SOURCE - 117V 60^{Hz} VARIAC REGULATED*
3. $\text{---} \text{---} \text{---}$ DESIGNATES CHASSIS GROUND.
4. $\text{---} \text{---} \text{---}$ DESIGNATES NEGATIVE "B".

SYLVANIA ELECTRIC PRODUCTS

CHASSIS: 1-645-1
MODELS: 4413 & 4422

TRAVLER MODEL 48-314

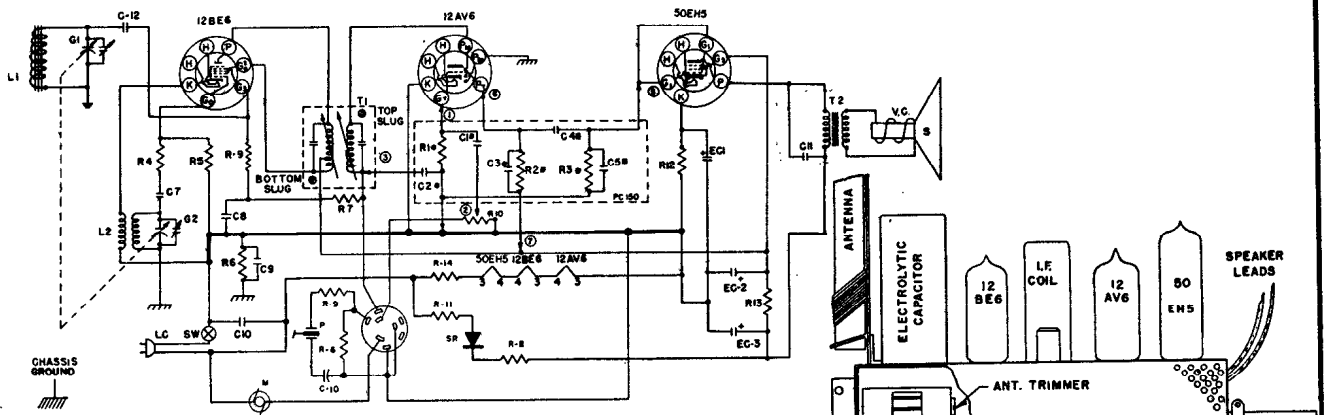

| PART NO | SYMBOL | DESCRIPTION |
|----------|--------|-------------------------------------|
| CC-12 | C7 | 47MMF CERAMIC CONDENSER |
| PG-5 | C8 | 05MF PAPER CONDENSER 400V |
| PG-5 | C9 | 05MF PAPER CONDENSER 400V |
| PG-5 | C10 | 05MF PAPER CONDENSER 400V |
| CC-3 | C11 | 005MF DISC CONDENSER 600V |
| PC-19 | PC-19 | COUPLATE |
| IR-17 | R-4 | 330HM 1/2W 20% CARBON RESISTOR |
| IR-9 | R-5 | 22K OHM 1/2W 20% CARBON RESISTOR |
| IR-20 | R-6 | 220K OHM 1/2W 20% CARBON RESISTOR |
| IR-23 | R-7 | 3.3MEG OHM 1/2W 20% CARBON RESISTOR |
| IR-41 | R-8 | 47 OHM 1W 10% CARBON RESISTOR |
| IR-12 | R-9 | 1MEG OHM 1/2W 20% CARBON RESISTOR |
| CC-33 | C-12 | 220MMFD 500V 20% CERAMIC TUB COND. |
| VC-64 | R-10 | 1MEG OHM VOLUME CONTROL |
| IR-17 | R-11 | 330HM 1/2W 20% CARBON RESISTOR |
| IR-14 | R-12 | 150 OHM 1/2W 20% CARBON RESISTOR |
| IR-25 | R-13 | 2200 OHM 1W 10% CARBON RESISTOR |
| EC-71A | EC-1 | 20MF-150VDC ELECTROLYTIC CONDENSER |
| | EC-2 | 30MF-150VDC |
| | EC-3 | 40MF-150VDC |
| CO-1 | LC | AC LINE CORD |
| GC-15 | G1 | ANT SECTION-WITH TRIMMER-GANG |
| GC-15 | G2 | OSC SECTION-WITH TRIMMER-CONDENSER |
| LO-28 | L1 | FERRIC ROD ANTENNA COIL |
| LL-55 | L2 | OSCILLATOR COIL |
| LI-12 | T1 | 455 KC TAPPED PRIMARY-1F COIL |
| SPK-22-C | SW | SPST SWITCH(PART OF VOLUME CONTROL) |
| | T2 | OUTPUT TRANSFORMER P.M |
| | VC | VOICE COIL WINDING SPEAKER |
| | S | SPEAKER |

* PARTS MARKED WITH AN ASTERISK ARE PART OF PC-150 SHOWN BELOW

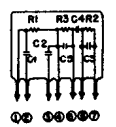

COMPONENTS & VALUES OF PC-150

| PART NO | SYMBOL | DESCRIPTION |
|---------|--------|----------------------------|
| 3-W-13 | M | 110 V. MOTOR-3 SPEED |
| PU-34 | P | PICKUP UP ARM SSR-TC-R-M |
| | | CARTRIIDGE |
| MR-47 | R-14 | 280 OHM-10 W. 5% WIREWOUND |
| SR-3 | SR | 85 ML. RECTIFIER |

IF. 455 KC.

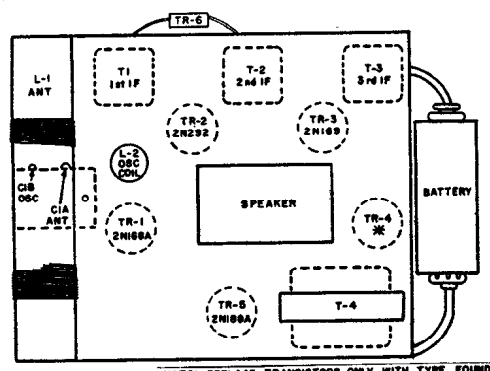

NOTE: REPLACE TRANSISTORS ONLY WITH TYPE FOUND IN RECEIVER
* TRANSISTOR PART NUMBER NO. 5C-12 OR GEN. ELEC. 2N107

MODELS-TR-280-A, 281-A, 282-A, 283-A

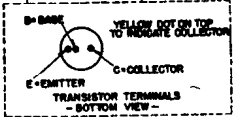
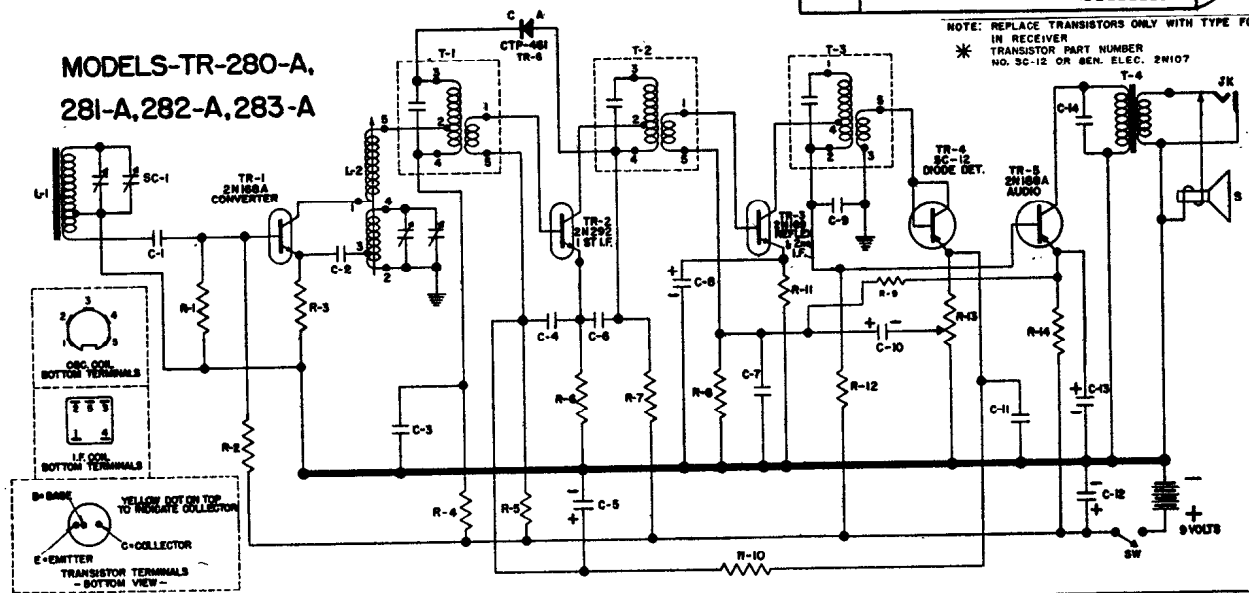

| PART NO | SYMBOL | DESCRIPTION | PART NO | SYMBOL | DESCRIPTION | PART NO | SYMBOL | DESCRIPTION | PART NO | SYMBOL | DESCRIPTION |
|---------|--------|----------------------|---------|--------|--|---------|--------|-----------------------------------|---------|--------|---------------|
| CC-55 | C-1 | D2 MFD. CERAMIC DISC | IR-64 | R-1 | 10K OHMS 1/2W 10% CARBON RESISTOR | LI-22 | T-1 | 1st STAGE I.F. TRANSFORMER | J-1 | JK | EARPHONE JACK |
| CC-35 | C-2 | 01 MFD. | IR-158 | R-2 | 33K | LI-23 | T-2 | 2nd STAGE I.F. TRANSFORMER | | | |
| CC-64 | C-3 | 01 MFD. | IR-29 | R-3 | 1500 | AT-33 | T-3 | 3rd STAGE I.F. TRANSFORMER | | | |
| CC-66 | C-4 | 01 MFD. | IR-159 | R-4 | 470 | TR-1 | TR-1 | 2N158A CONVERTER TRANSISTOR | | | |
| CC-65 | C-5 | 01 MFD. | IR-3 | R-5 | 82K | SC-9 | TR-2 | 2N292 1st I.F. | | | |
| CC-66 | C-6 | 01 MFD. | IR-159 | R-6 | 330 | SC-9 | TR-3 | 2N158 2nd I.F. & DET. | | | |
| CC-65 | C-7 | 01 MFD. | IR-159 | R-7 | 4700 | SC-10 | TR-4 | SC-12 OR 2N107 DIODE | | | |
| CC-66 | C-8 | 01 MFD. | IR-159 | R-8 | 4700 | SC-11 | TR-5 | 2N158A 3rd I.F. TRANSFORMER | | | |
| CC-66 | C-9 | 01 MFD. | IR-159 | R-9 | 4700 | SC-12 | TR-6 | DET. & A.F. BLACK-GERMANIUM DIODE | | | |
| CC-66 | C-10 | 01 MFD. | IR-108 | R-10 | 3300 | SW | SW | SWITCH ON VOLUME CONTROL | | | |
| CC-66 | C-11 | 01 MFD. | IR-159 | R-11 | 470 | L-1 | L-1 | PM SPEAKER | | | |
| CC-66 | C-12 | 01 MFD. | IR-159 | R-12 | 1500 | LI-1 | L-2 | ANT. ASSEMBLY | | | |
| CC-66 | C-13 | 01 MFD. | IR-159 | R-13 | 1500 | LI-2 | L-3 | OSCILLATOR COIL | | | |
| CC-66 | C-14 | 01 MFD. | IR-104 | R-14 | 10K OHMS VOLUME CONTROL WITH 850V 100 OHM 1/2W 10% CARBON RESISTOR | GC-15 | GC-15 | GANG CONDENSER SECTION & WINDING | | | |

TRAVLER MODEL 90-105

FOR LOCAL FM STATIONS. THIRD WIRE IN LINE CORD.

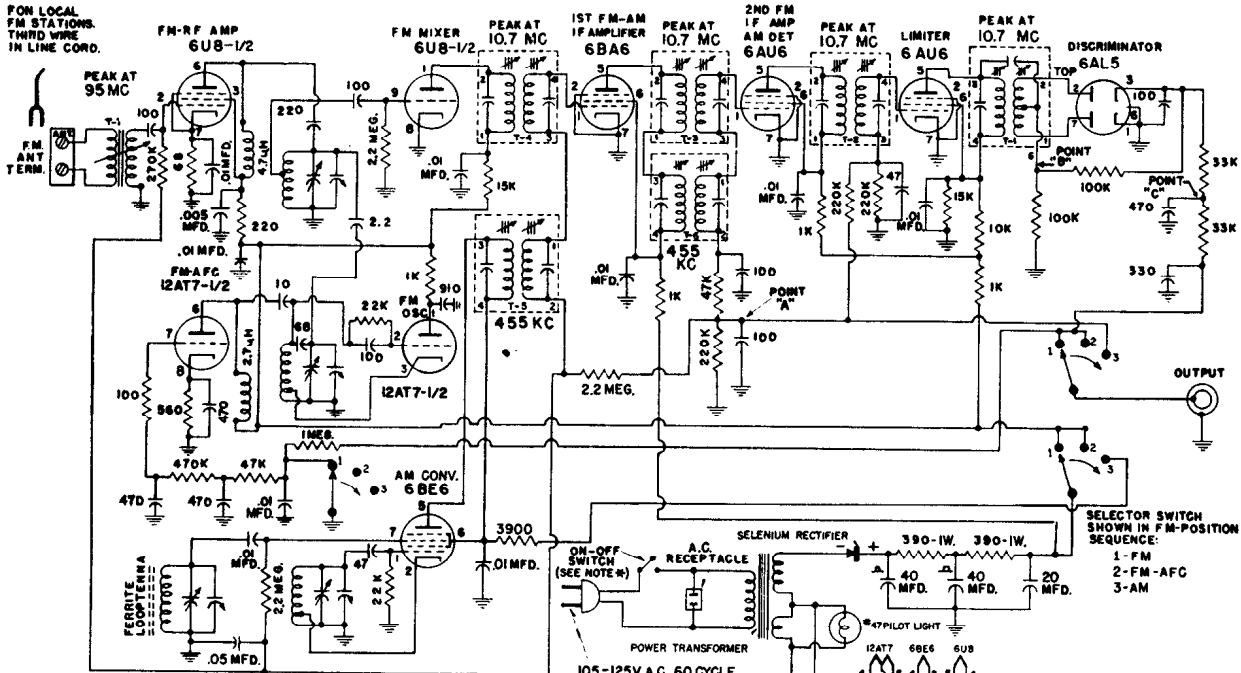

NOTE: ALL CAPACITANCE VALUES IN MMF. EXCEPT WHERE OTHERWISE SPECIFIED. ALL RESISTANCE VALUES IN OHMS EXCEPT WHERE OTHERWISE SPECIFIED.

* NOTE: SWITCH ON SELECTOR SHAFT IN TA-100 TUNER ONLY.

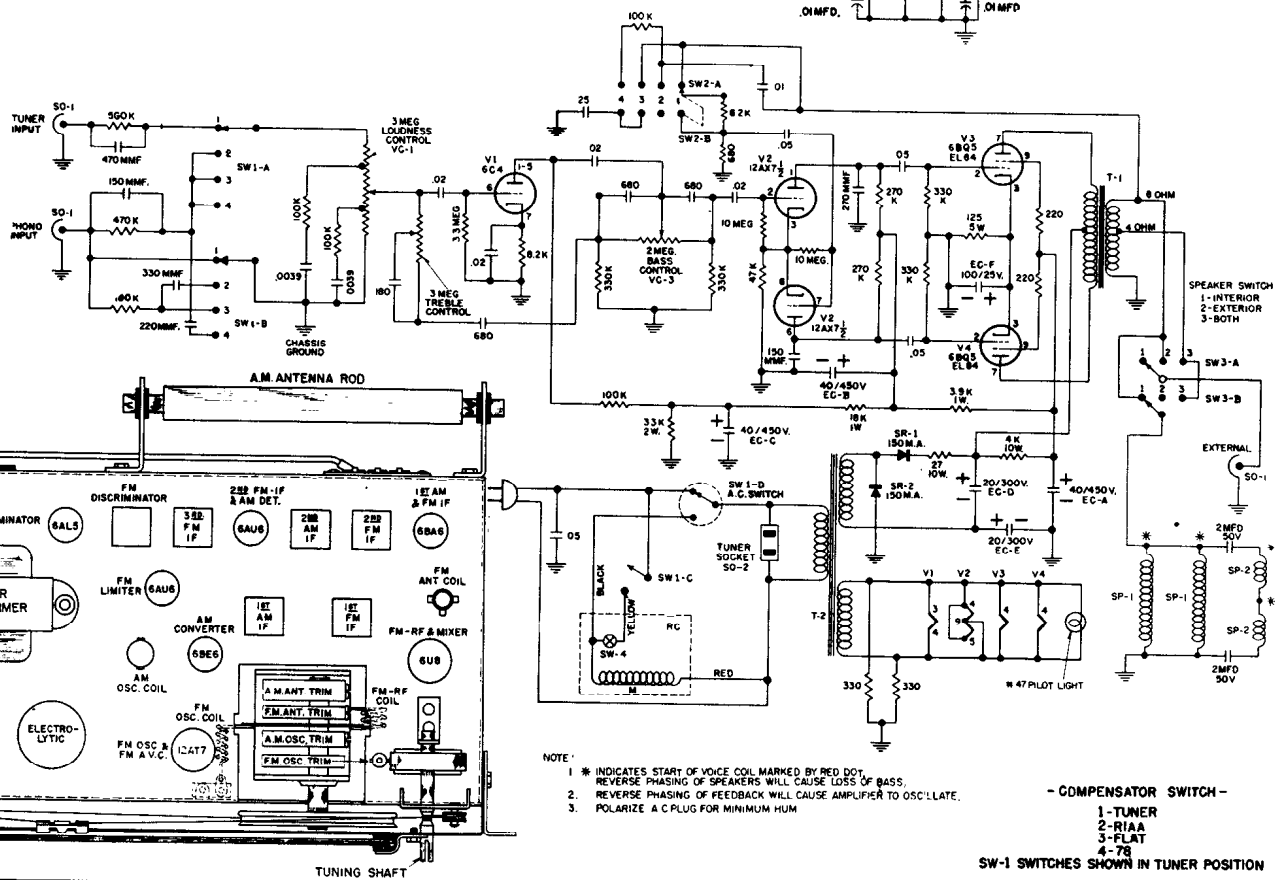

NOTE: 1. * INDICATES START OF VOICE COIL MARKED BY RED DOT. REVERSE PHASING OF SPEAKERS WILL CAUSE LOSS OF BASS. 2. REVERSE PHASING OF FEEDBACK WILL CAUSE AMPLIFIER TO OSCILLATE. 3. POLARIZE A C PLUG FOR MINIMUM HUM

- COMPENSATOR SWITCH -

- 1-TUNER
- 2-RIAA
- 3-FLAT
- 4-78

SW-1 SWITCHES SHOWN IN TUNER POSITION

VOLUME R-19, MOST-OFTEN-NEEDED 1959 RADIO SERVICING INFORMATION

WEBCOR Models 1953, 1991, using AM Tuner 73X014-1, Amplifiers 14X278-1, -2

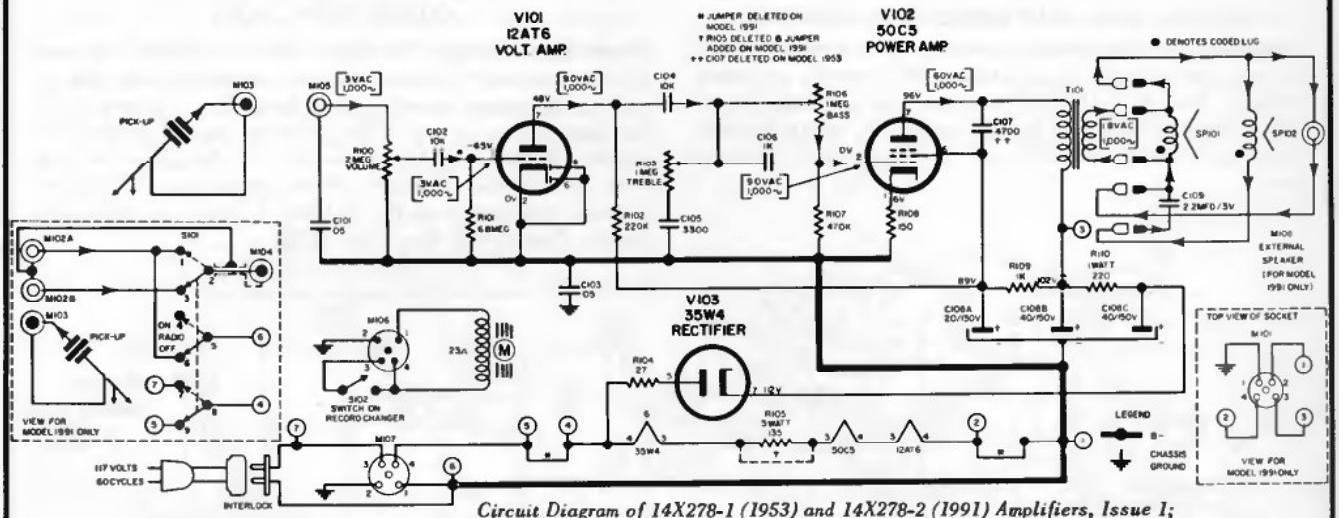

Circuit Diagram of 14X278-1 (1953) and 14X278-2 (1991) Amplifiers, Issue 1; and 73X014-1 (1991) AM Tuner, Issue 1.

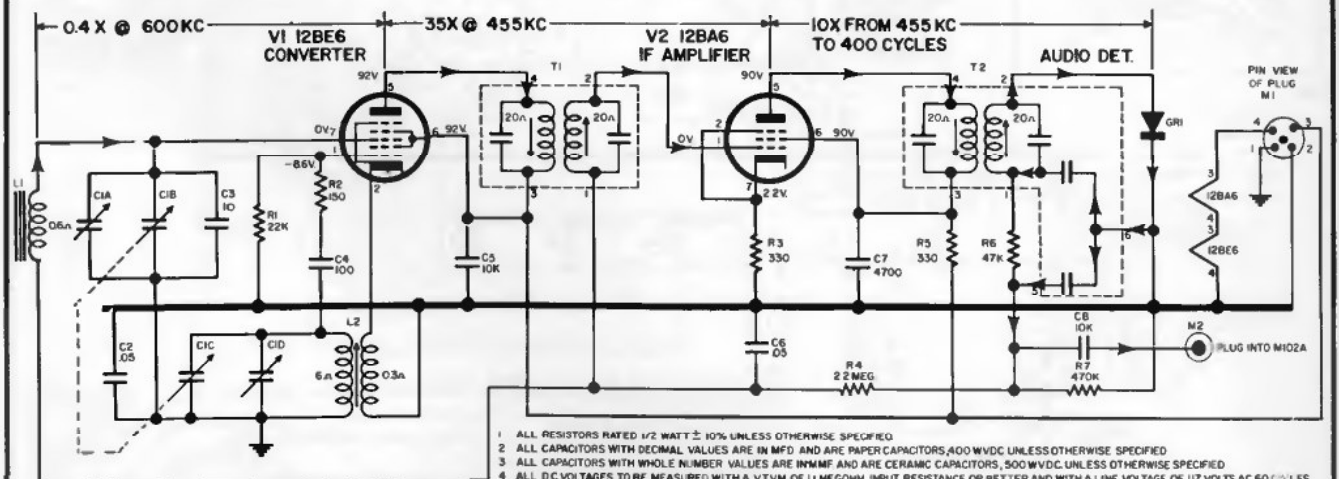

- 1 ALL RESISTORS RATED 1/2 WATT ± 10% UNLESS OTHERWISE SPECIFIED
- 2 ALL CAPACITORS WITH DECIMAL VALUES ARE IN MFD AND ARE PAPER CAPACITORS, 500 WVDC UNLESS OTHERWISE SPECIFIED
- 3 ALL CAPACITORS WITH WHOLE NUMBER VALUES ARE IN MMF AND ARE CERAMIC CAPACITORS, 500 WVDC UNLESS OTHERWISE SPECIFIED
- 4 ALL DC VOLTAGES TO BE MEASURED WITH A VTVM OF 11 MEGOHM INPUT RESISTANCE OR BETTER AND WITH A LINE VOLTAGE OF 117 VOLTS AC 60 CYCLES
- 5 VOLTAGE READINGS TAKEN FROM POINT INDICATED TO B-
- 6 AUDIO AMPLIFIER AC VOLTAGES TAKEN WITH 1000 CYCLE INPUT, ALL CONTROLS AT MAXIMUM CLOCKWISE ROTATION AND 32 OHM DUMMY LOAD OR SPEAKER
- 7 STAGE GAINS OF AM TUNER MEASURED FOR STANDARD TEST OUTPUT VOLTAGE OF 50 MV

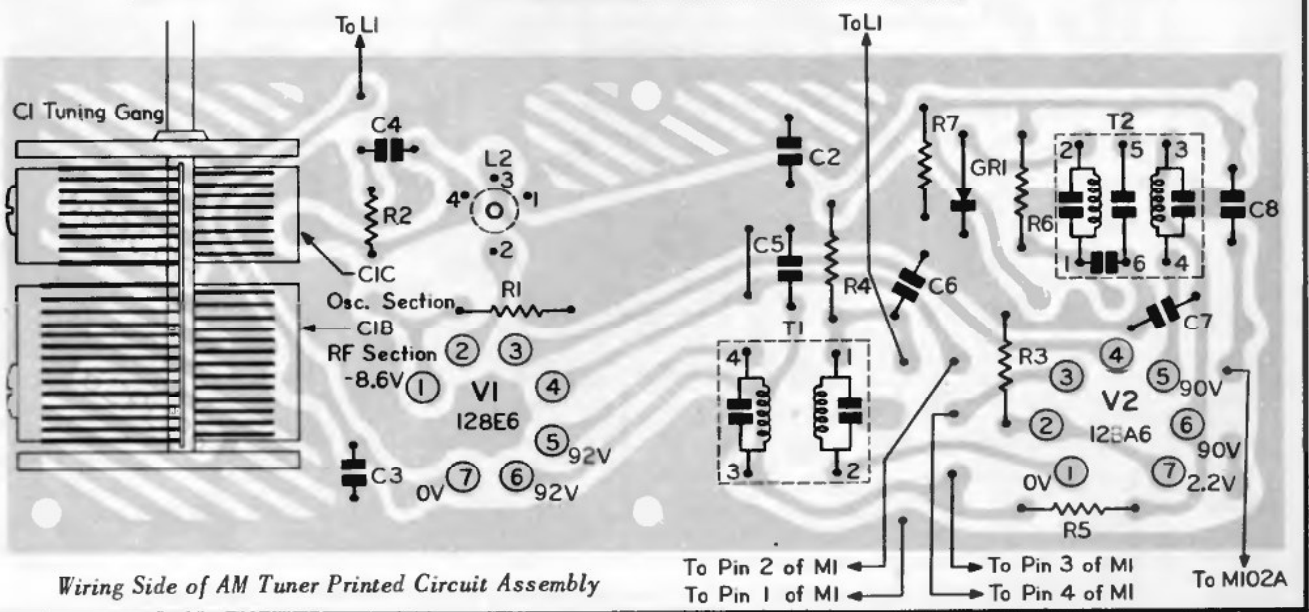

Wiring Side of AM Tuner Printed Circuit Assembly

WEBCOR Model 1954-1, using Amplifier 14X280-1

NEEDLE AND CARTRIDGE REPLACEMENT

If distortion or harshness of treble tones is encountered, it is probable that the cartridge and needle assembly (Webcor Part No. 21P586) requires replacement. To replace the cartridge and needle assembly, grasp the cartridge with thumb and forefinger and gently pull cartridge free.

CONNECTION JACKS

Stereo Output Jack: The Stereo Output Jack on the rear of the Holiday Coronet Cabinet makes it possible to connect a second sound system (amplifier and speakers) for Stereafonic reproduction. Webcor Model 4905 Companion Stereafonic Sound System is designed for use with the Holiday Coronet. When using the 4905 Sound System, connection to the Holiday Coronet is made with Stereo Connecting Cord No. 2933.

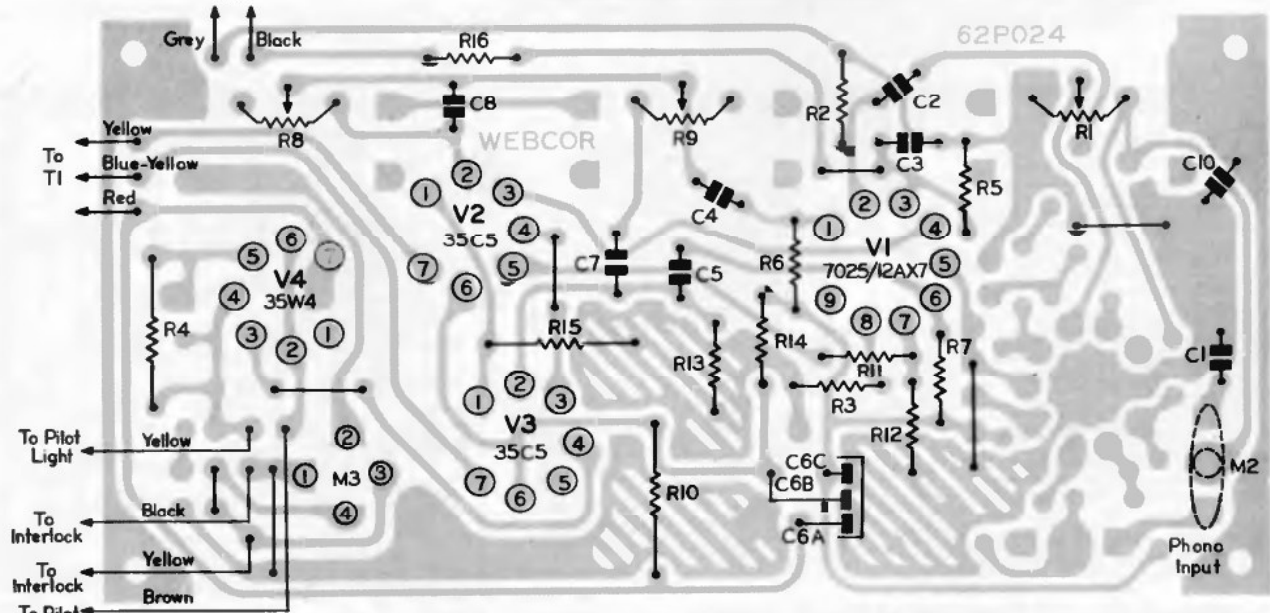
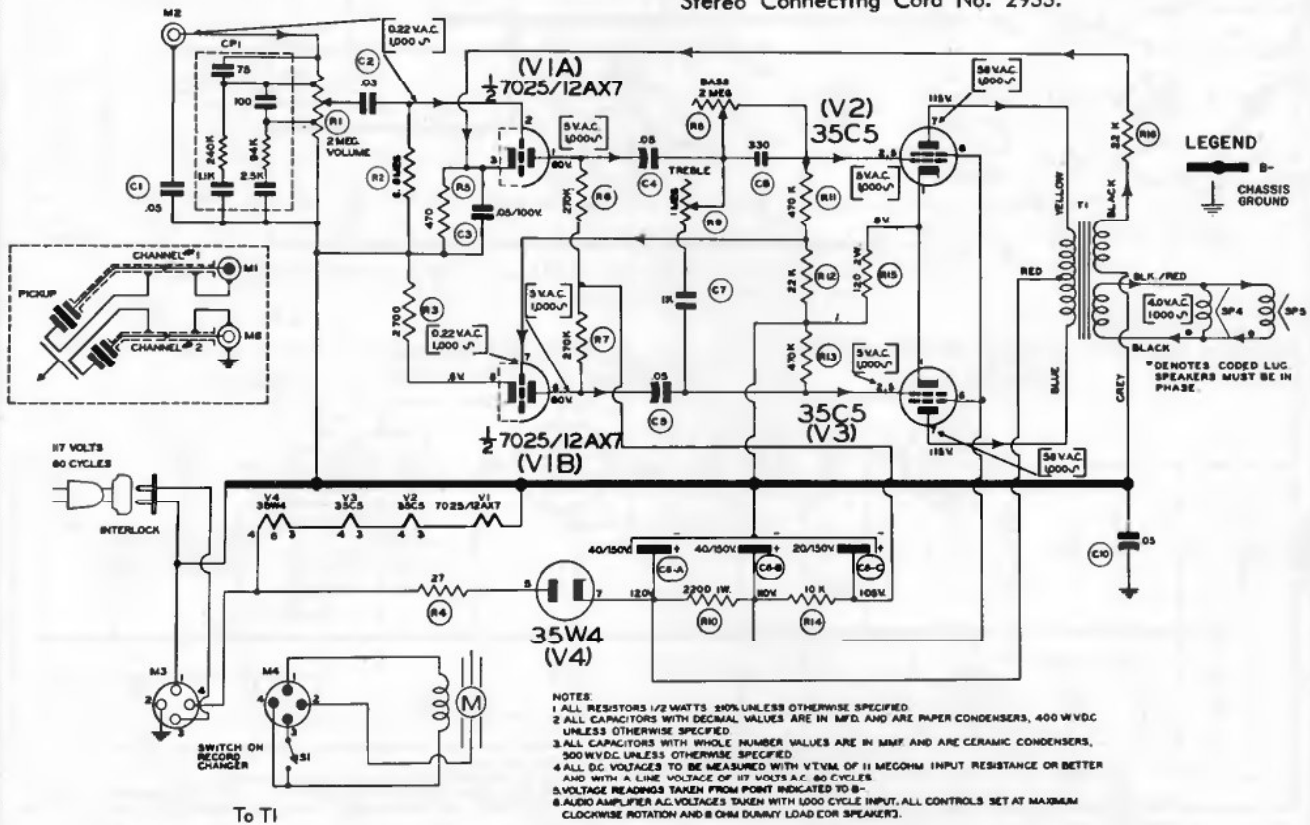

WEBCOR Model 1956, using Amplifier 14X307

Model 1956 is a Stereo-Fidelity Fonograf that contains a 5", 3.2 ohm speaker for the right channel (Ch. 1) and a 5", 3.2 ohm speaker for the left channel (Ch. 2). Each speaker is mounted in the case side by side at a 7 degree angle for better separation of the right and left channels. In addition an External

Speaker Output Jack is incorporated. This jack permits connecting a 3.2 ohm External Speaker System to the fonograf if additional separation of the 2 channels is desired. When an External Speaker System is plugged into the External Speaker Output Jack, the left channel speaker in the fonograf is cut out.

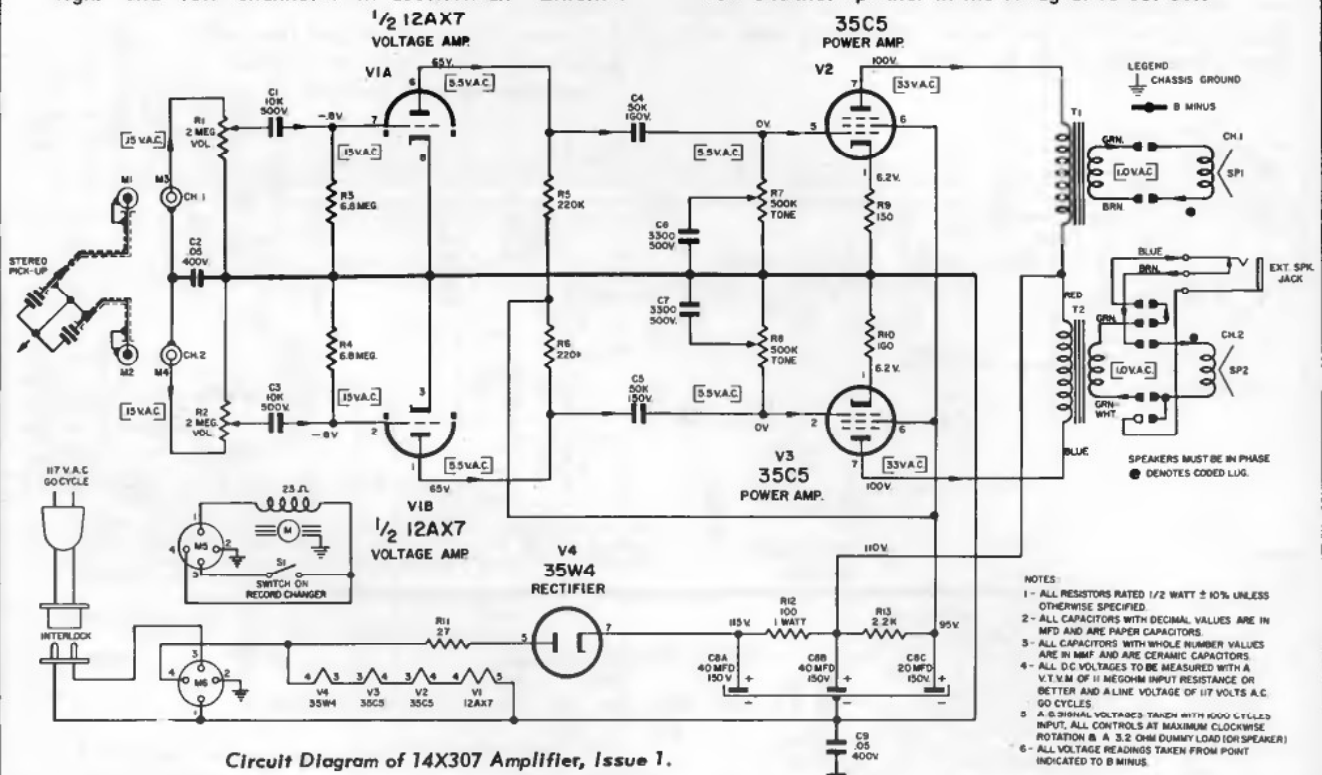

Circuit Diagram of 14X307 Amplifier, Issue 1.

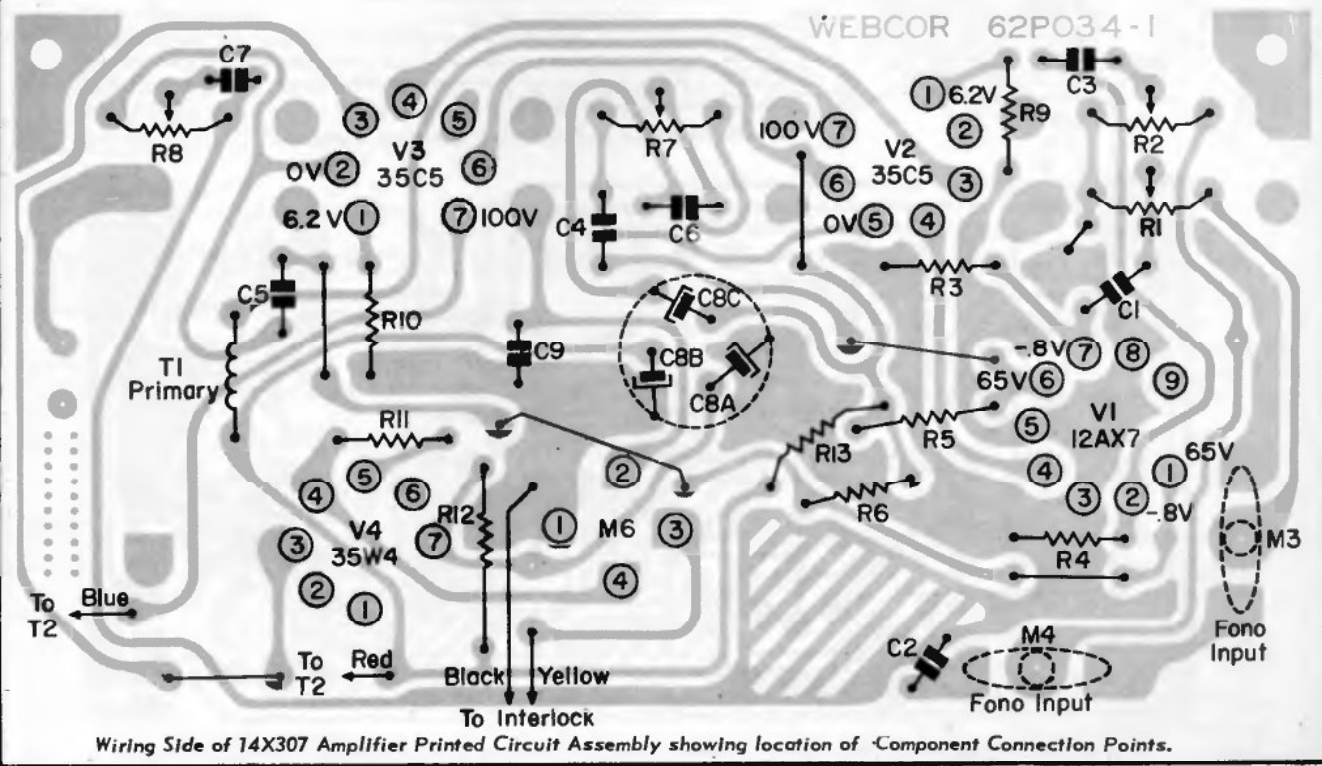

Wiring Side of 14X307 Amplifier Printed Circuit Assembly showing location of Component Connection Points.

WEBCOR Model 1963, using Amplifier 14X280-2

Stereo Output Jack: The Stereo Output Jack on the rear of the Holiday Imperial Cabinet makes it possible to connect a second sound system (amplifier and speakers) for Stereofonic reproduction. Webcor Model 4905 Companion Stereofonic Sound System is designed for use with the Holiday Imperial. When using the 4905 Sound System, connection to the Holiday Imperial is made with Stereo Connecting Cord No. 2933.

When replacing cartridge housing and bracket assembly (Webcor Part No. 21P587), connect leads from pick-up cord as follows:

1. Connect red lead to silver terminal.
2. Connect shield to terminal adjacent to silver terminal.
3. Connect white lead to gold terminal.
4. Connect black lead to terminal adjacent to gold terminal.

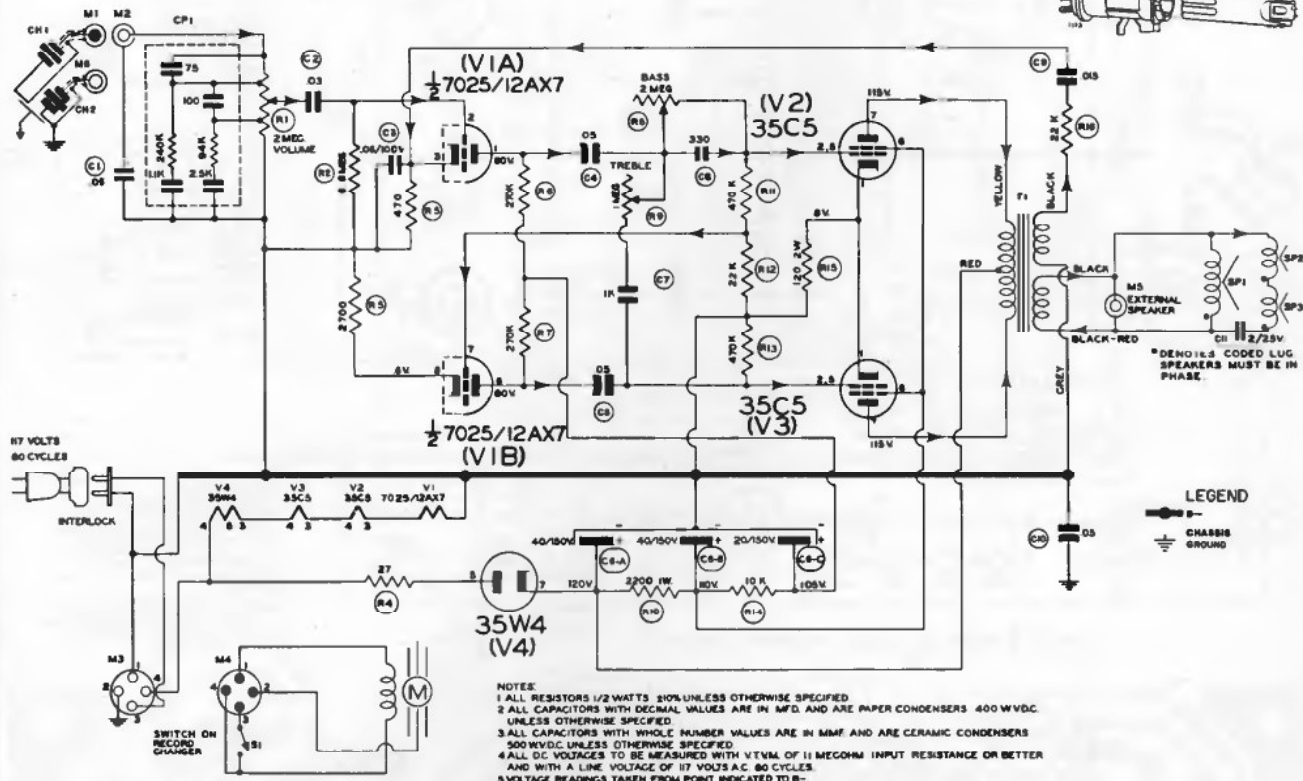
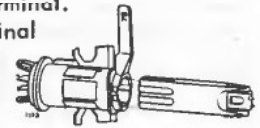

Circuit Diagram of 14X280-2 Amplifier, Issue 1.

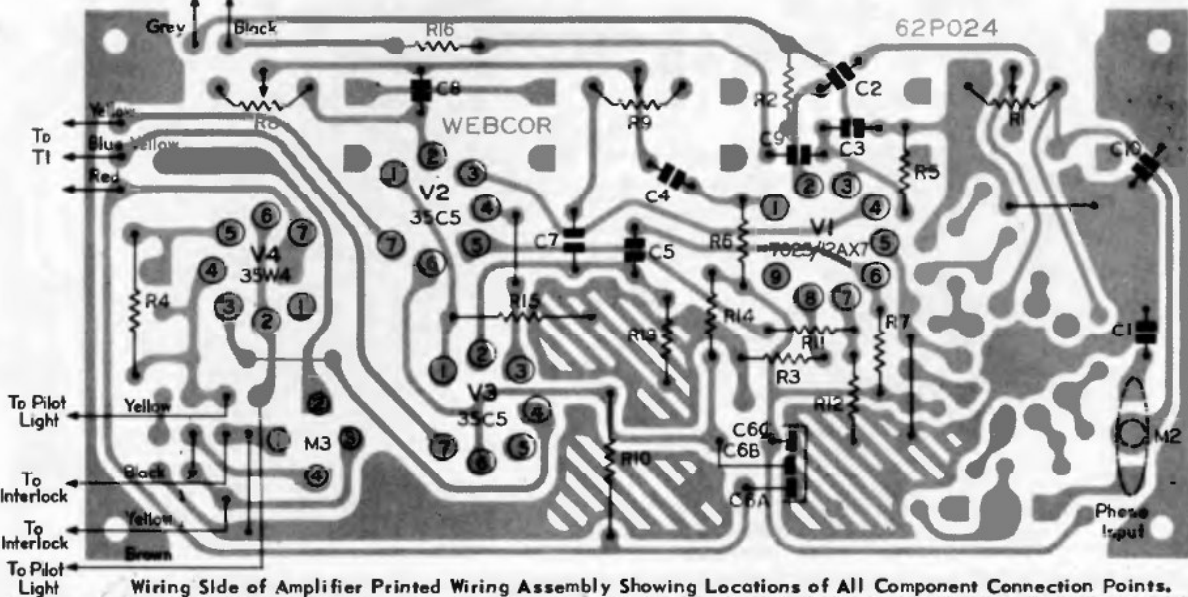

Wiring Side of Amplifier Printed Wiring Assembly Showing Locations of All Component Connection Points.

WESTERN AUTO SUPPLY CO.

MODELS D2832A & D2834A D2832B & D2834B

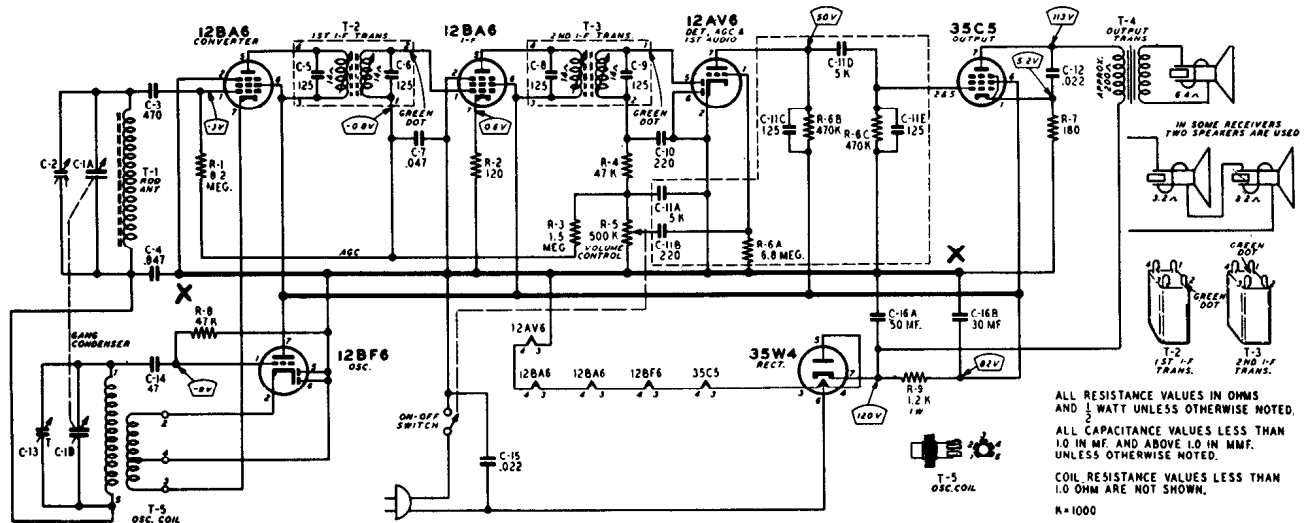

TUBE SOCKET VOLTAGES

Socket voltages are shown on the schematic diagram at the tube socket terminals. All voltages are between the socket terminal and "X" point. Voltages were taken with a vacuum tube voltmeter. Conditions of measurement are:

- Line voltage 117 Volts AC
- Signal Input None
- A Variation of $\pm 10\%$ is usually permissible.

SPECIFICATIONS

- 6 Tube Superheterodyne, Including Rectifier Tube.
- Tuning Frequency Range 540 to 1600 KC
- Power Consumption 35 watts (At 117 volts AC)
- Power Output 1.3 watt maximum, 0.8 watt (10% distortion)
- Intermediate Frequency 455 KC
- Sensitivity 80 Microvolts Per Meter Average
- Selectivity 50 KC Wide at 1000 Times Signal
- Speaker 4" PM Dynamic

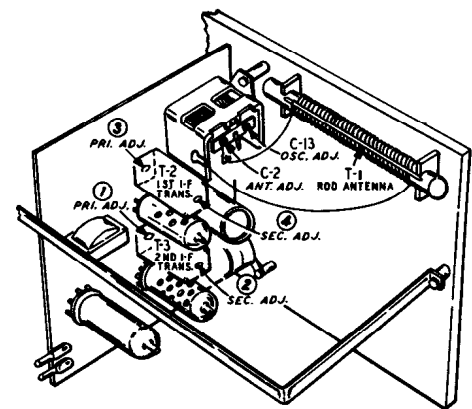

ALIGNMENT PROCEDURE

The following equipment is required for aligning: Signal Generator which will provide an accurately calibrated signal at the test frequencies as listed. Output Indicating Meter; Non-Metallic Screwdriver.

Dummy Antennas—.1 mf., 50 mmf.
Volume Control—Maximum All Adjustments.
Allow Chassis and Signal Generator to "Heat Up" for several Minutes.

| FREQUENCY SETTING | SIGNAL GENERATOR ANTENNA CONNECTION | GROUND CONNECTION | DUMMY ANTENNA | GANG CONDENSER SETTING | ADJUST TUNING SLUGS (I.F.) AND TRIMMERS TO MAXIMUM |
|-------------------|---|-------------------|---------------|---------------------------|--|
| 455 KC | Control Grid 12BA6-I.F. Prong No. 1 | "X" Point | .1 mf. | Turn Rotor to full open | 2nd I.F. Pri. (1) & Sec. (2) |
| 455 KC | Control Grid 12BA6 Mixer Prong No. 1 | "X" Point | .1 mf. | Turn Rotor to full open | 1st I.F. Pri. (3) & Sec. (4) 2nd I.F. Pri. (1) & Sec. (2) |
| 1620 KC | Control Grid 12BA6 Mixer Prong No. 1 | "X" Point | .1 mf. | Turn Rotor to full open | Oscillator (C-13) |
| 1400 KC | Std. Loop Connected to Signal Generator | | | Tune Receiver to 1400 KC. | Antenna (C-2) Trimmer |

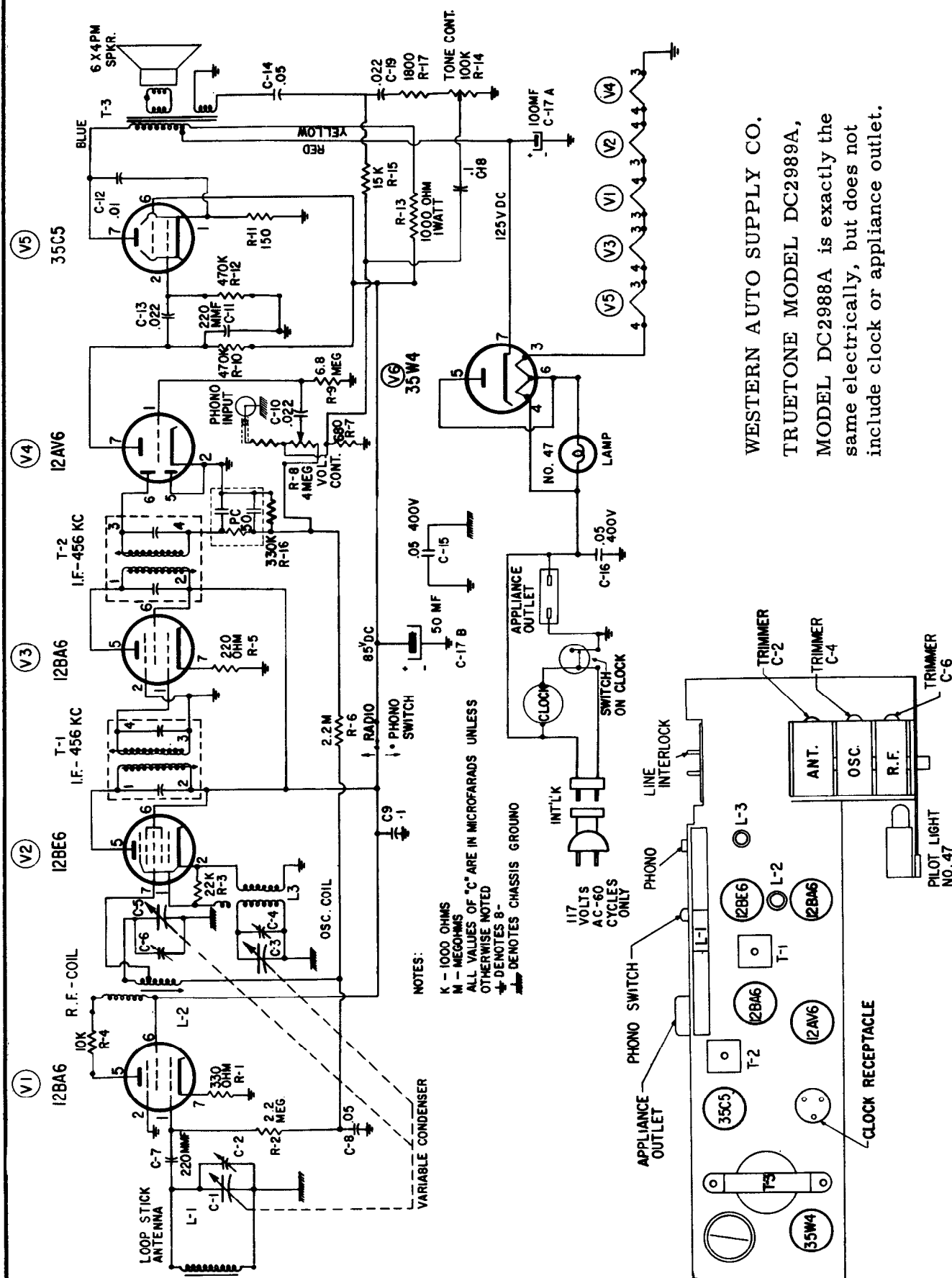

NOTES:
 K - 1000 OHMS
 M - MEGOHMS
 ALL VALUES OF "C" ARE IN MICROFARADS UNLESS OTHERWISE NOTED
 * DENOTES 8-
 † DENOTES CHASSIS GROUND

WESTERN AUTO SUPPLY CO.
 TRUETONE MODEL DC2989A,
 MODEL DC2988A is exactly the same electrically, but does not include clock or appliance outlet.

Westinghouse

MODELS H-629T4A, H-630T4A, H-631T4A,
CHASSIS V-2239-7

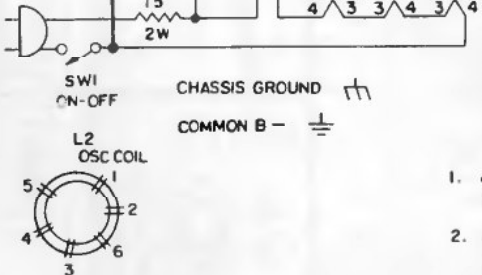
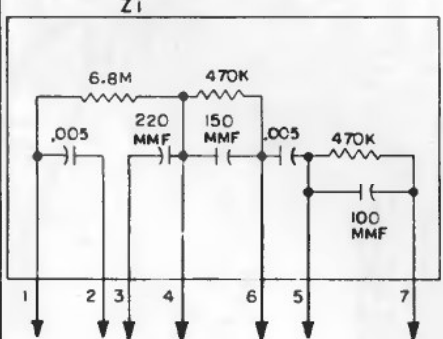
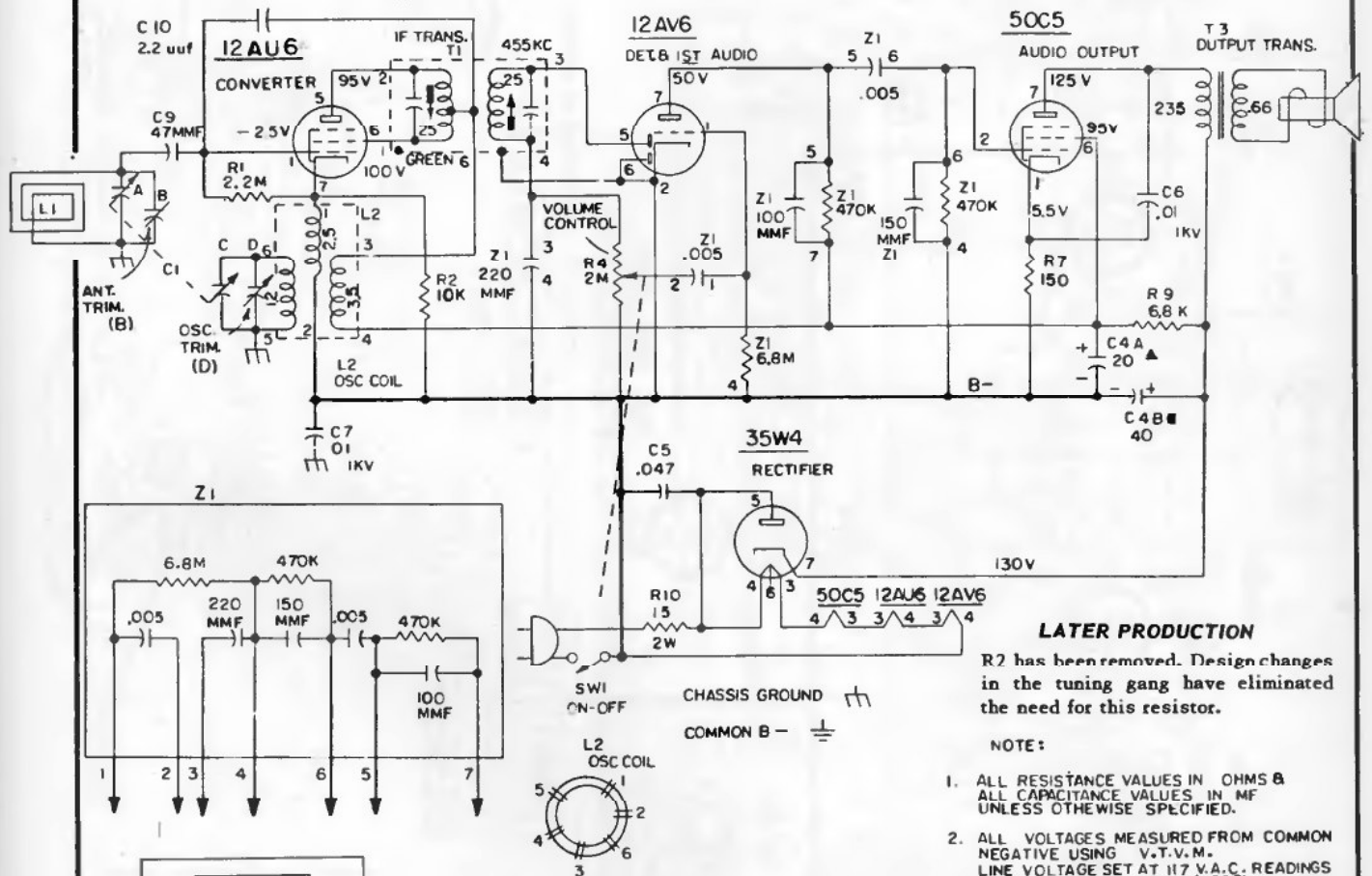

LATER PRODUCTION
R2 has been removed. Design changes in the tuning gang have eliminated the need for this resistor.

NOTE:

1. ALL RESISTANCE VALUES IN OHMS & ALL CAPACITANCE VALUES IN MF UNLESS OTHERWISE SPECIFIED.
2. ALL VOLTAGES MEASURED FROM COMMON NEGATIVE USING V.T.V.M. LINE VOLTAGE SET AT 117 V.A.C. READINGS SHOULD BE AS SHOWN $\pm 20\%$

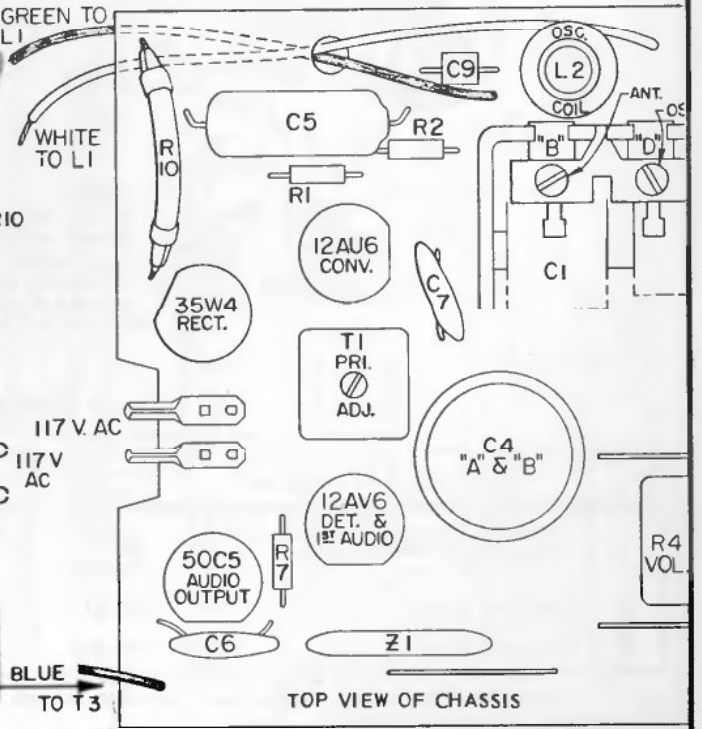
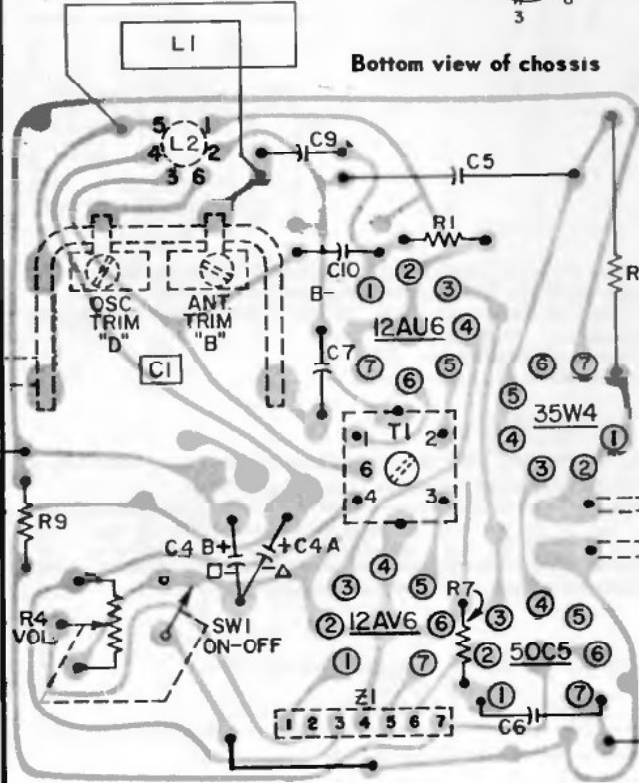

OFTEN-NEEDED 1959 RADIO SERVICING

WESTINGHOUSE Chassis V-2239-6,
Models H-677T4, H-678T4, H-679T4

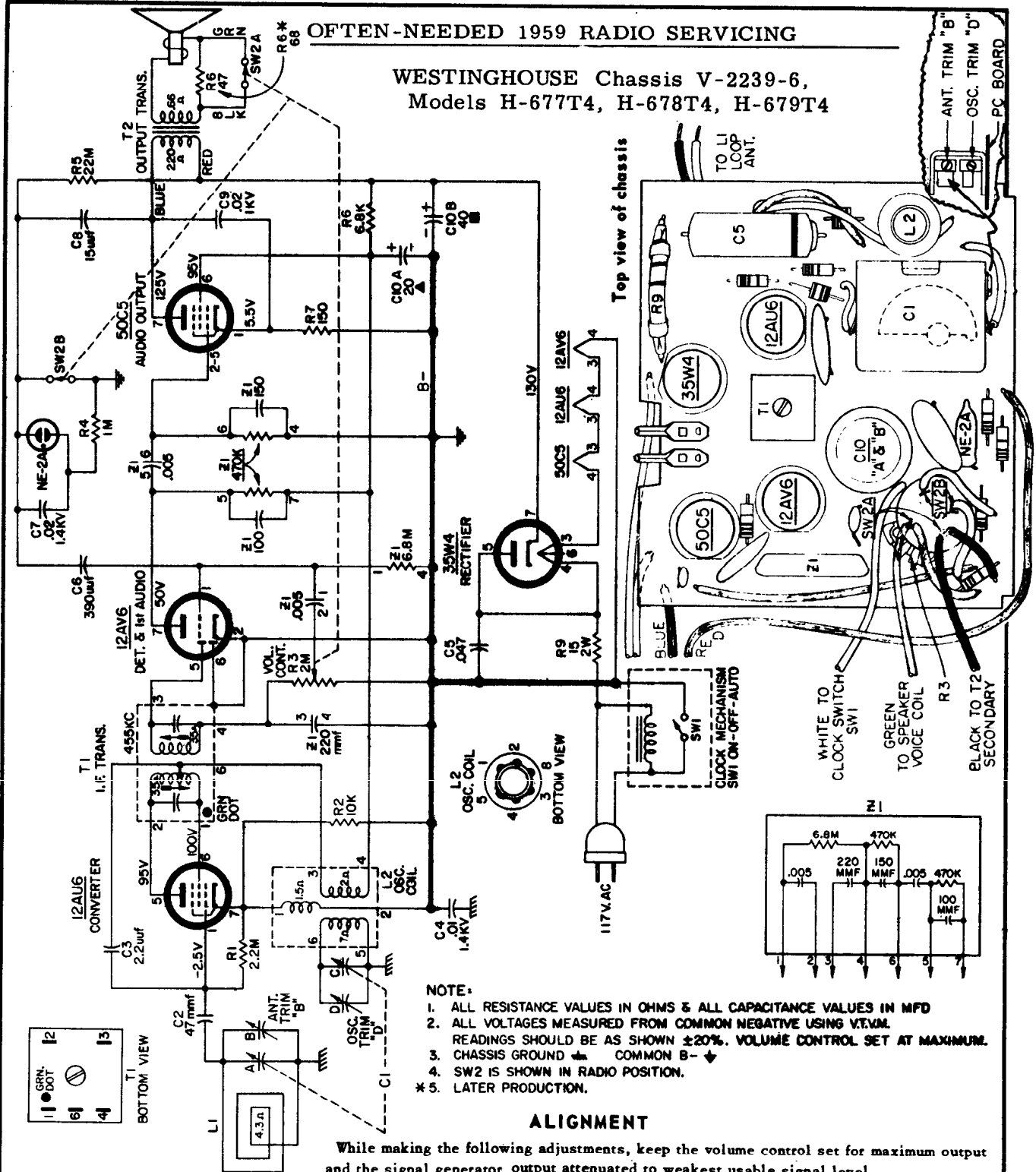

- NOTE:**
1. ALL RESISTANCE VALUES IN OHMS & ALL CAPACITANCE VALUES IN MFD
 2. ALL VOLTAGES MEASURED FROM COMMON NEGATIVE USING VTVM.
 3. READINGS SHOULD BE AS SHOWN $\pm 20\%$. VOLUME CONTROL SET AT MAXIMUM.
 4. CHASSIS GROUND \blacktriangle COMMON B-
 5. SW2 IS SHOWN IN RADIO POSITION.
- * 5. LATER PRODUCTION.

ALIGNMENT

While making the following adjustments, keep the volume control set for maximum output and the signal generator output attenuated to weakest usable signal level.

| Step | Connect Signal Generator to - | Signal Gen. Frequency | Radio Dial | Connect VTVM Across Voice Coil and Adjust for Maximum Output - |
|------|--|-------------------------------|------------------|--|
| 1 | Stator of ant. tuning capacitor (A) through a 2DD mmf capacitor. | 455KC 400 Cps. 30% Mod. | Minimum capacity | Top and bottom slugs of T1. * |
| 2 | Radiated signal | 1625 KC | Minimum capacity | Oscillator trimmer (D) |
| 3 | Radiated signal | 1400 KC | 1400 KC | Antenna trimmer (B) |

* It is recommended that a fiber aligning tool that snugly fits the slot in the powdered iron core be used to prevent chipping of the slot.

VOLUME R-19, MOST-OFTEN-NEEDED 1959 RADIO

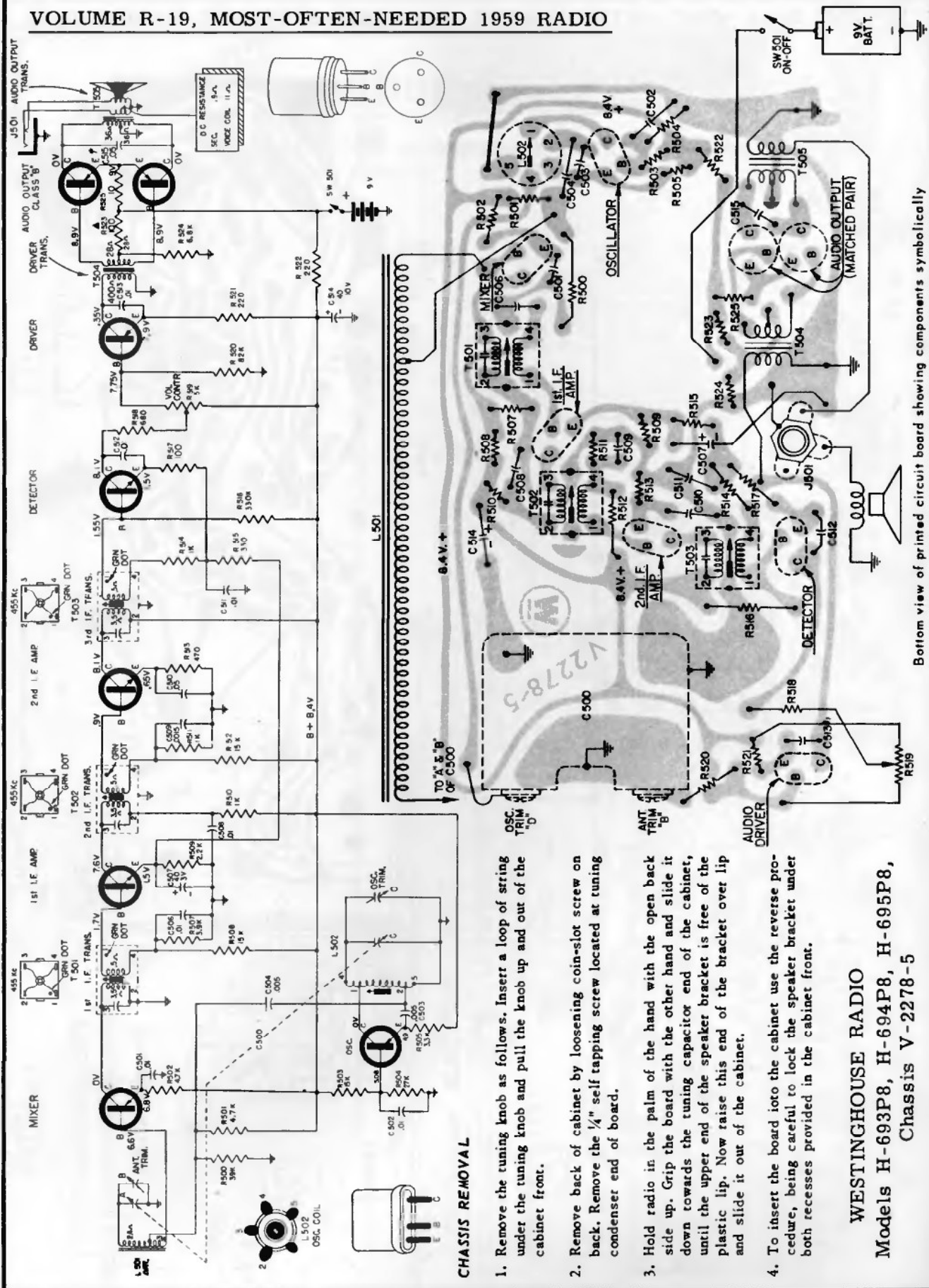

Bottom view of printed circuit board showing components symbolically

CHASSIS REMOVAL

1. Remove the tuning knob as follows. Insert a loop of string under the tuning knob and pull the knob up and out of the cabinet front.
2. Remove back of cabinet by loosening coin-slot screw on back. Remove the 1/4" self tapping screw located at tuning condensator end of board.
3. Hold radio in the palm of the hand with the open back side up. Grip the board with the other hand and slide it down towards the tuning capacitor end of the cabinet, until the upper end of the speaker bracket is free of the plastic lip. Now raise this end of the bracket over lip and slide it out of the cabinet.
4. To insert the board into the cabinet use the reverse procedure, being careful to lock the speaker bracket under both recesses provided in the cabinet front.

WESTINGHOUSE RADIO
 Models H-693P8, H-694P8, H-695P8,
 Chassis V-2278-5

Westinghouse

Models H-632T5A, H-633T5A,
Chassis V-2390-4

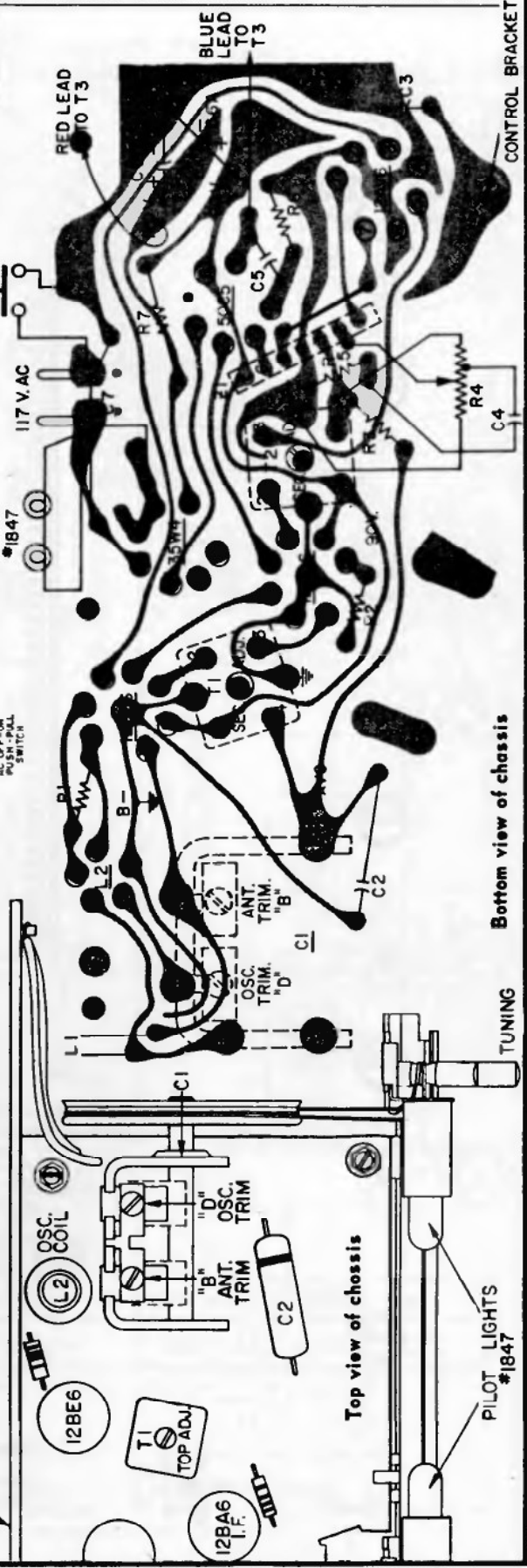
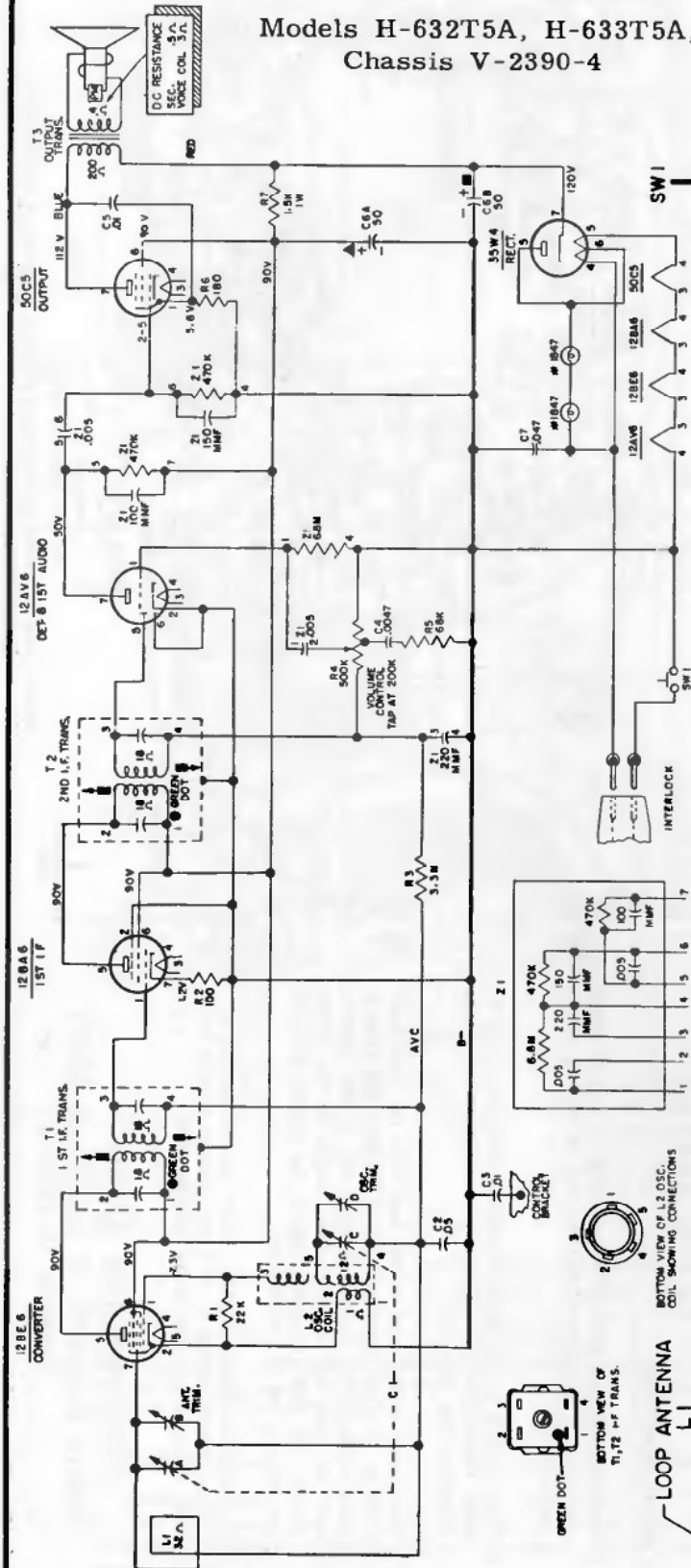

Westinghouse Chassis V-2393-1

Models H-655P5, H-656P5, H-657P5

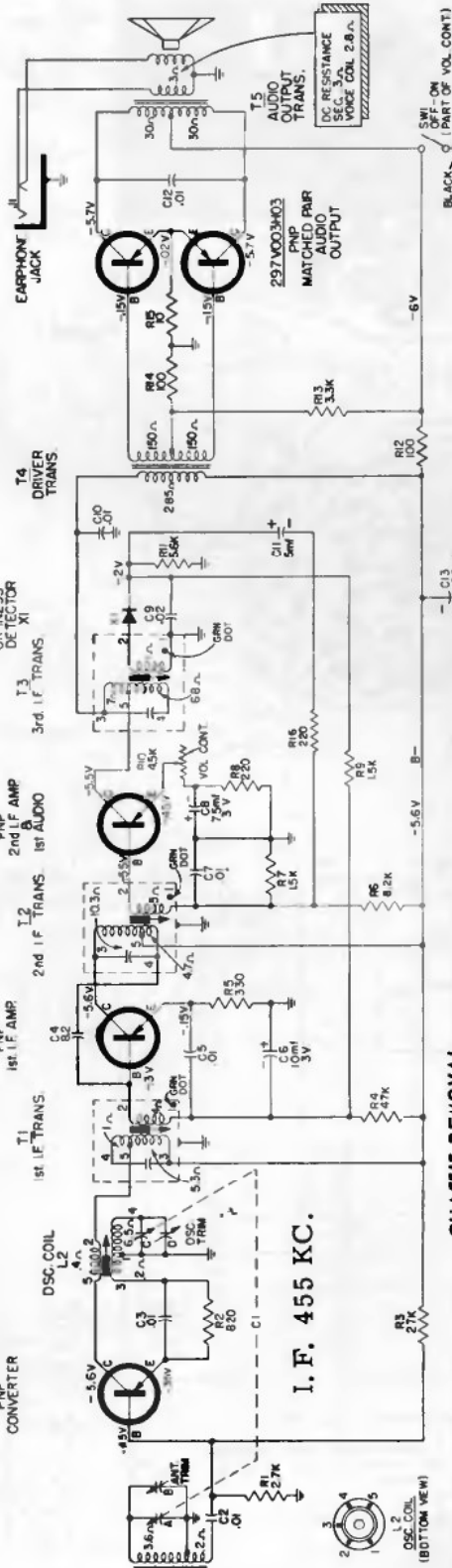

CHASSIS REMOVAL

1. Remove the tuning knob as follows. Insert a loop of string under the tuning knob and pull the knob up and out of the cabinet front.
2. Remove the carrying handle. Grasp the handle on both sides and carefully spread it apart until it clears the holes in the cabinet sides.
3. Remove the back of the cabinet by loosening the two coin-slot screws on the back.
4. Remove the two 1" long hex head screws securing the chassis to the cabinet front.
5. Remove the printed circuit chassis, battery case, speaker spacers, rubber grommet and speaker.
6. To insert the printed circuit chassis back into the cabinet use the reverse procedure. *The tuning knob and cabinet back screws must be the same or identical to the original dimensions to prevent possible damage to the tuning gang.*

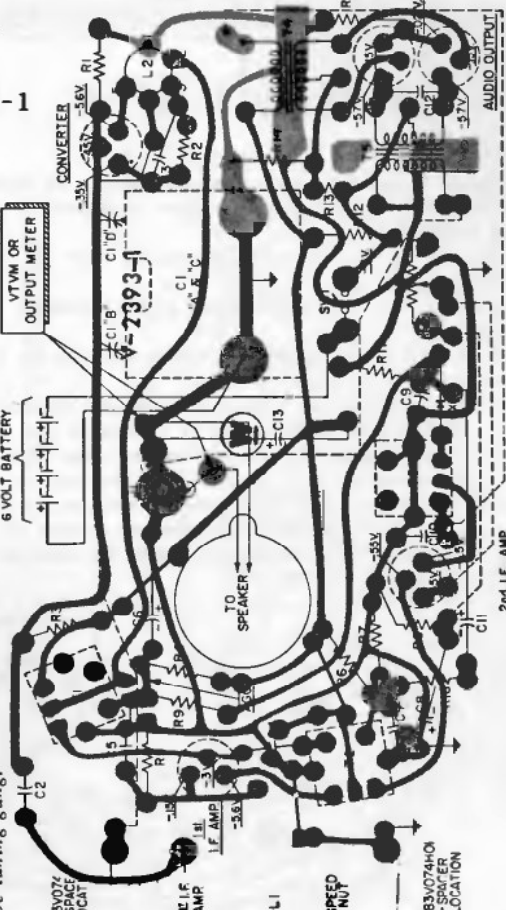
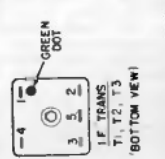

BOTTOM VIEW OF PRINTED CIRCUIT CHASSIS SHOWING COMPONENTS SYMBOLICALLY

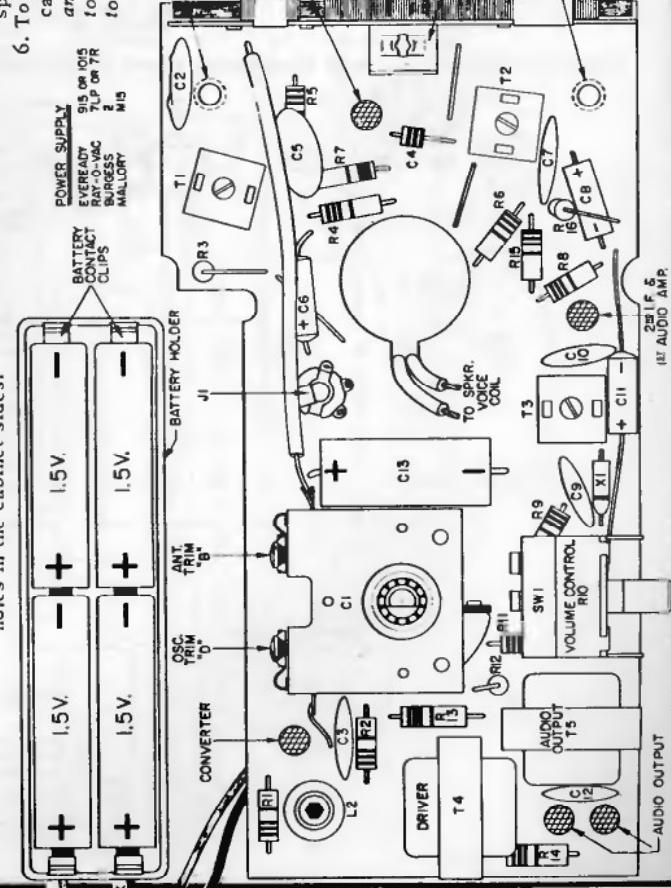

TOP VIEW OF PRINTED CIRCUIT CHASSIS

Westinghouse

Chassis V-2394-1, Models H-659P4, H-660P4

CHASSIS REMOVAL (See figure 1)

1. Press in the two cabinet release buttons on either side of the receiver case. Open the case to expose the chassis and batteries.
2. Unsnap the battery cable assemblies from the "A" and "B" batteries.
3. Remove the two self-tapping screws securing the AC receptacle.
4. Remove the two self-tapping screws securing the chassis bracket to the top of the case.
5. Carefully slide the chassis out from the receiver case. The on-off-volume control knob is captivated and thus remains in the case as the control shaft is pulled off the knob.

When servicing with the receiver connected to the AC power line use an isolation transformer between the receiver and the AC line. To replace the chassis reverse the above procedure. Be careful to correctly seat the chassis in the cabinet mounting grooves.

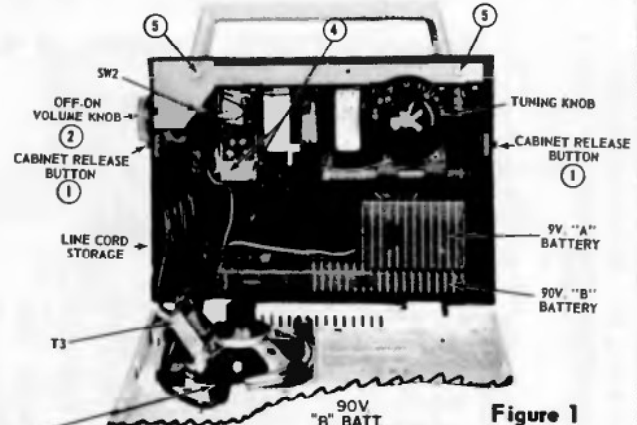
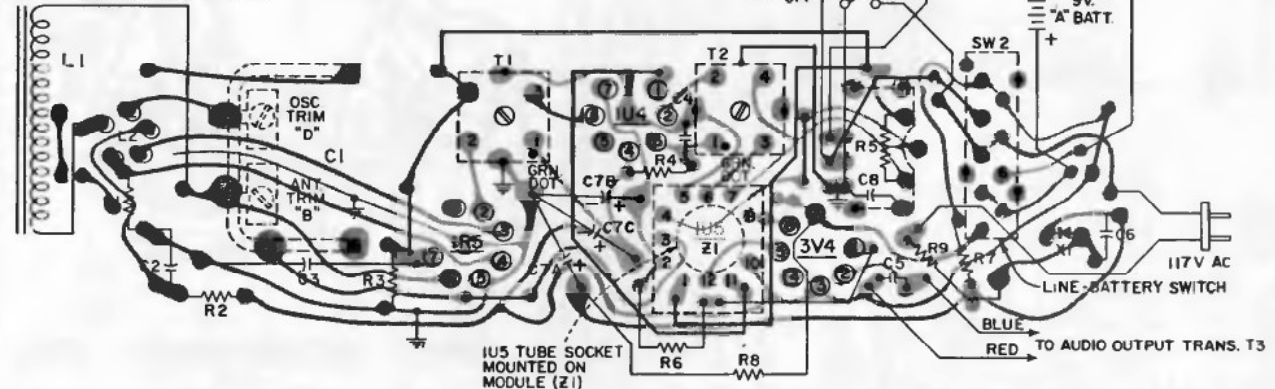
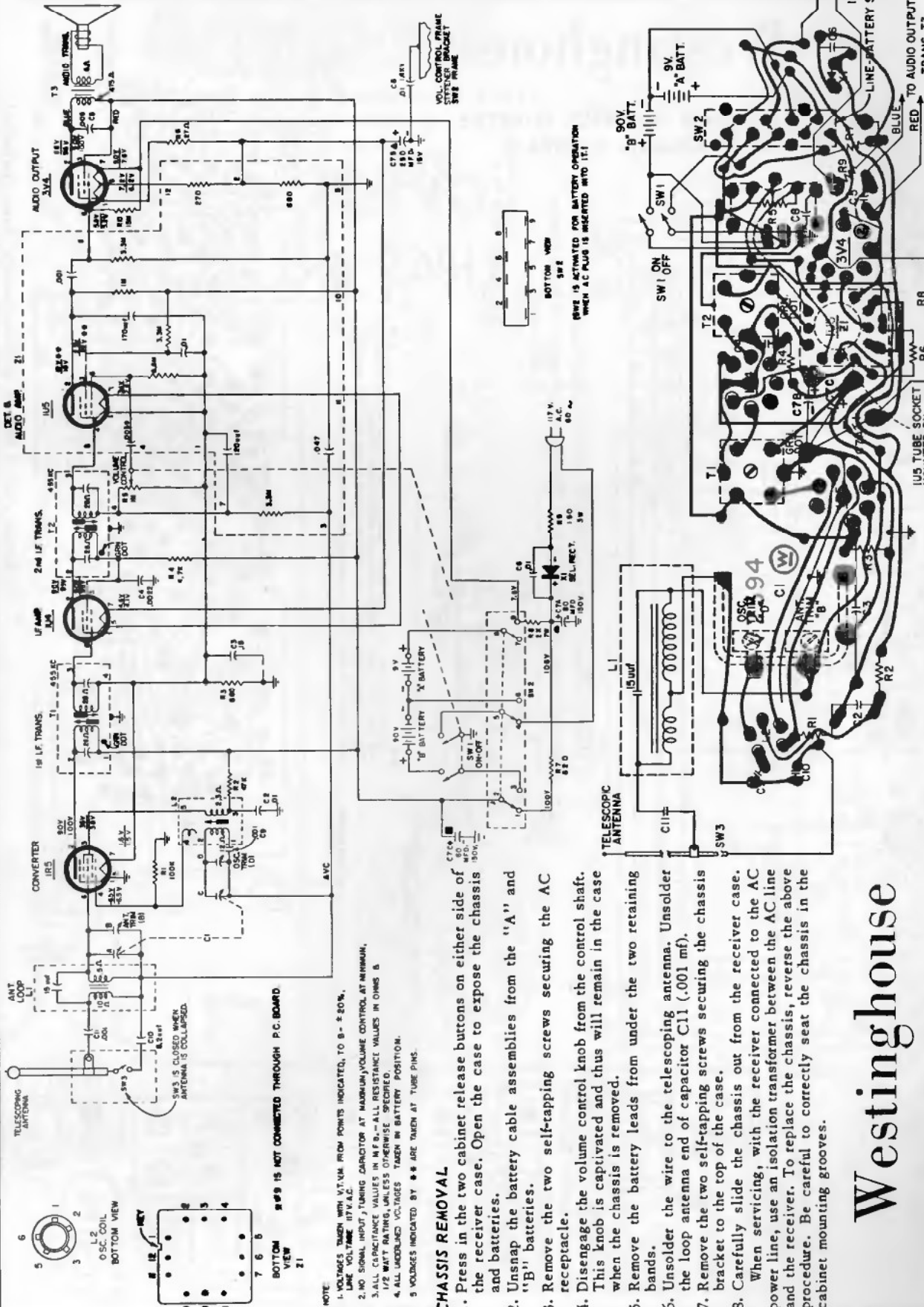

Figure 1





Bottom view of chassis with components shown symbolically

Westinghouse

Models H-662P4, H-663P4, H-664P4,
Chassis V-2394-2

NOTE:
 1. VOLTAGES TAKEN WITH VT.V.M. FROM POINTS INDICATED, TO B+ = 80%.
 2. NO SIGNAL INPUT, TUNING CAPACITOR AT MAXIMUM VOLUME CONTROL AT MINIMUM.
 3. ALL CAPACITANCE VALUES IN M.F.D.—ALL RESISTANCE VALUES IN OHMS & 1/2 WATT RATING, UNLESS OTHERWISE SPECIFIED.
 4. ALL UNLOADING VOLTAGES TAKEN IN BATTERY POSITION.
 5. VOLTAGES INDICATED BY * ARE TAKEN AT TUBE PINS.

CHASSIS REMOVAL

1. Press in the two cabinet release buttons on either side of the receiver case. Open the case to expose the chassis and batteries.
 2. Unsnap the battery cable assemblies from the "A" and "B" batteries.
 3. Remove the two self-rapping screws securing the AC receptacle.
 4. Disengage the volume control knob from the control shaft. This knob is captivated and thus will remain in the case when the chassis is removed.
 5. Remove the battery leads from under the two retaining bands.
 6. Unsolder the wire to the telescoping antenna. Unsolder the loop antenna end of capacitor C11 (.001 mf).
 7. Remove the two self-rapping screws securing the chassis bracket to the top of the case.
 8. Carefully slide the chassis out from the receiver case.
- When servicing, with the receiver connected to the AC power line, use an isolation transformer between the AC line and the receiver. To replace the chassis, reverse the above procedure. Be careful to correctly seat the chassis in the cabinet mounting grooves.

Westinghouse

Models H-666P5, H-667P5,
Chassis V-2394-3

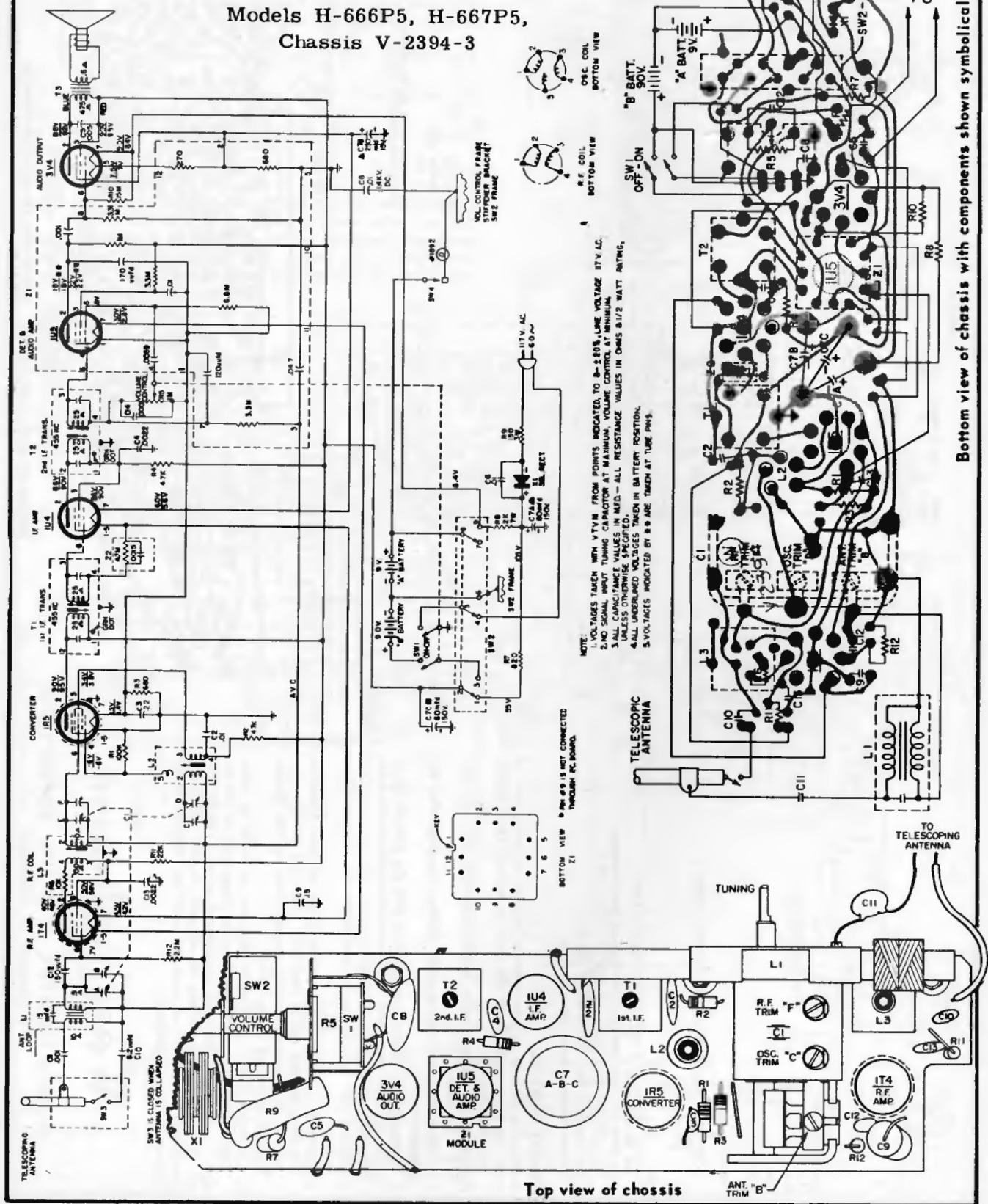

Bottom view of chassis with components shown symbolically

Westinghouse

Models H-681T5, H-682T5, H-683T5,
Chassis V-2395-1

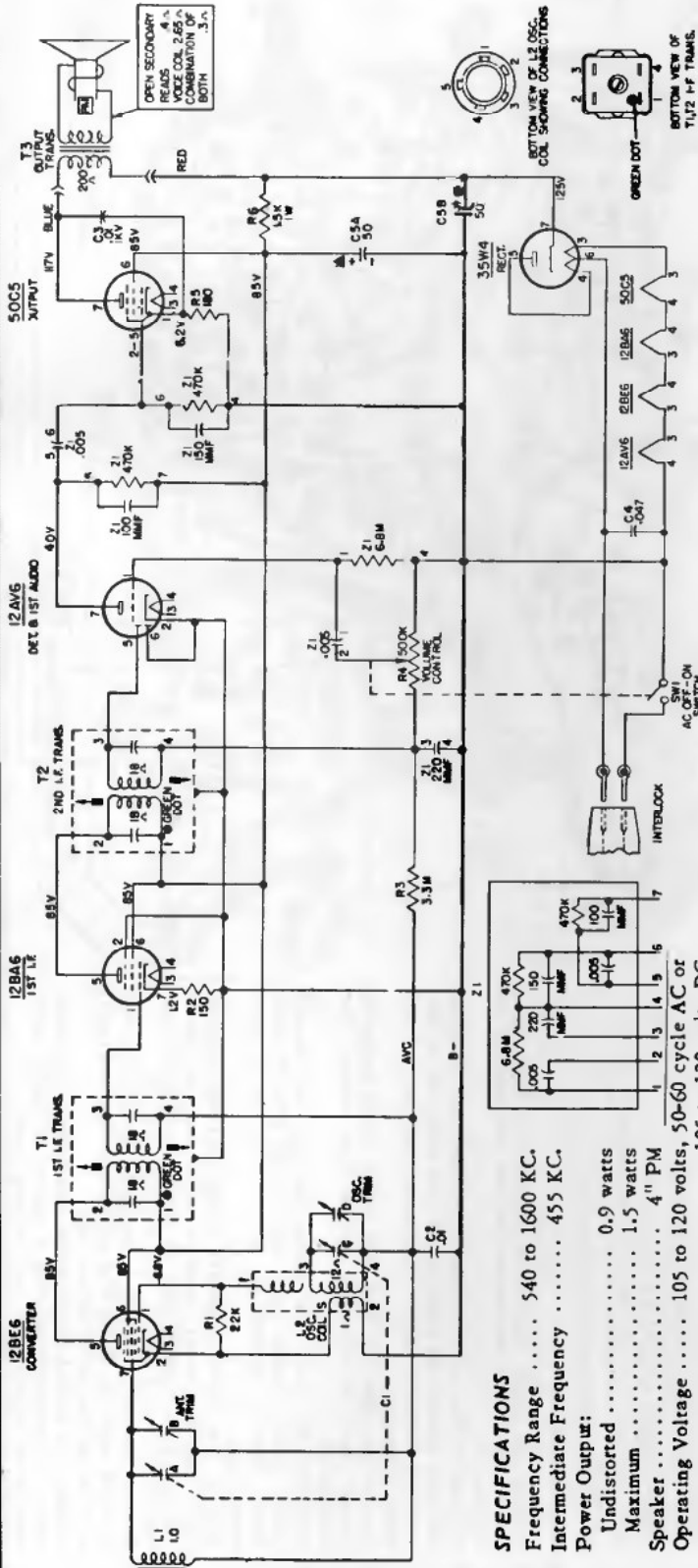

NOTES:
1. ALL VOLTAGES MEASURED FROM COMMON NEGATIVE USING A V.T.V.M. VOLUME CONTROL AT MINIMUM, TUNING CAPACITOR AT MAXIMUM. LINE VOLTAGE SET AT 117V. A.C. READINGS SHOULD BE AS SHOWN $\pm 20\%$.
2. ALL CAPACITANCE VALUES IN MFD. AND ALL RESISTANCE VALUES IN OHMS UNLESS OTHERWISE SPECIFIED.

SPECIFICATIONS

- Frequency Range 540 to 1600 KC.
- Intermediate Frequency 455 KC.
- Power Output:
Undistorted 0.9 watts
Maximum 1.5 watts
- Speaker 4" PM
- Operating Voltage 105 to 120 volts, 50-60 cycle AC or 105 to 120 volts DC
- Power Consumption 30 watts

PRINTED BOARD REMOVAL

1. Disengage captivated volume control knob (located on side of cabinet) from volume control shaft.
2. Remove two screws from rear of cabinet.
3. Loosen screw on bottom of cabinet slightly; then push forward on this screw to disengage AC line cord interlock.
4. Remove screw from bottom of cabinet. Front panel and attached PC board can now be removed from cabinet.
5. For PC board installation reverse the above procedure.

FRONT PANEL REMOVAL

1. Remove front panel and attached PC board as described under PRINTED BOARD REMOVAL.
 2. Unsolder red and blue leads from audio output transformer (transformer is mounted on speaker).
 3. Remove the screw securing loop antenna assembly to front panel.
 4. Remove two screws attaching PC board stiffener bracket to front panel.
 5. For front panel installation * reverse the above procedure.
- * NOTE: The tuning knob must be replaced before PC board assembly is attached to front panel.

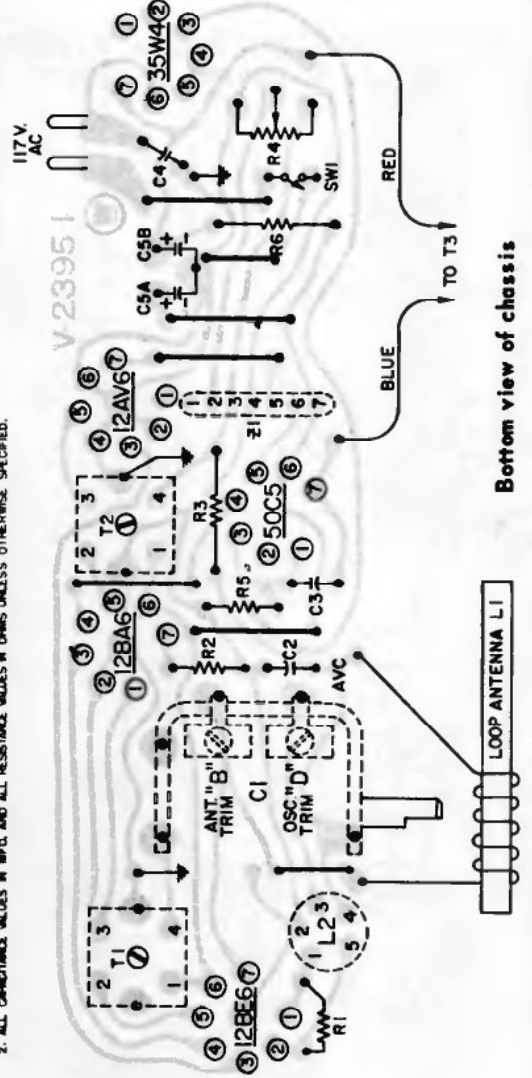

WESTINGHOUSE Chassis V-2396-1
Models H-685P8, H-686P8

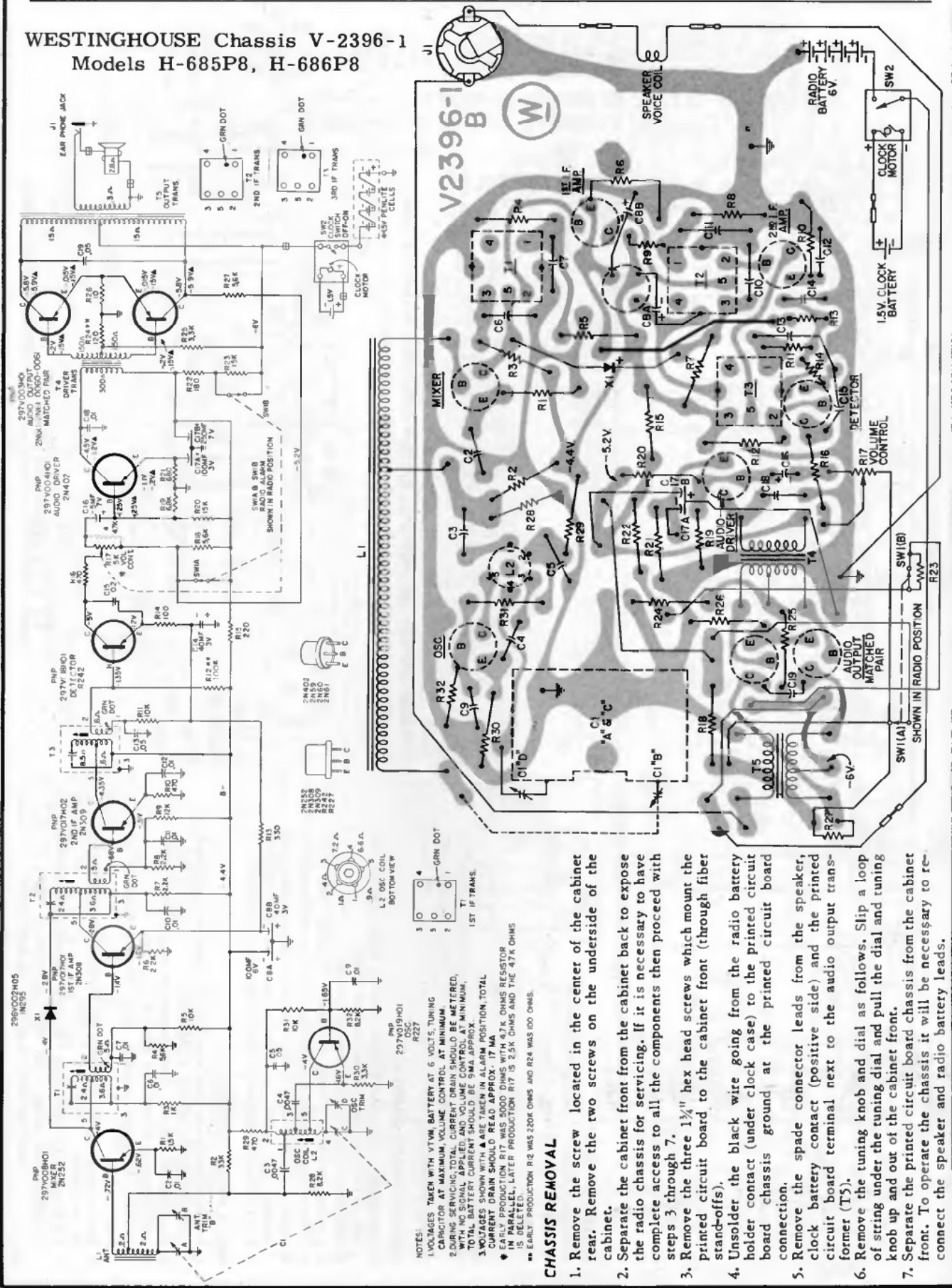

NOTES:
 1. VOLTAGES TAKEN WITH VTVM BATTERY AT 6 VOLTS. TUNING CAPACITOR AT MAXIMUM VOLUME CONTROL. AT MINIMUM. 2. DURING SERVICING, TOTAL CURRENT DRAIN SHOULD BE METERED, WITH NO SIGNAL APPLIED, AND VOLUME CONTROL AT MINIMUM. TOTAL BATTERY CURRENT SHOULD BE 5 MA APPROX. 3. VOLTAGES SHOWN WITH A ARE TAKEN IN ALL AM POSITION. TOTAL CURRENT DRAIN SHOULD READ APPROX. 17 MA. * EARLY PRODUCTION RT1 WAS 5000 OHMS WITH 4.7 K OHMS RESISTOR IS DELETED, LATER PRODUCTION RT1 IS 2.5 K OHMS AND THE 4.7 K OHMS IS DELETED. ** EARLY PRODUCTION R2 WAS 220K OHMS AND R24 WAS 100 OHMS.

CHASSIS REMOVAL

1. Remove the screw located in the center of the cabinet rear. Remove the two screws on the underside of the cabinet.
2. Separate the cabinet front from the cabinet back to expose the radio chassis for servicing. If it is necessary to have complete access to all the components then proceed with steps 3 through 7.
3. Remove the three 1 1/4" hex head screws which mount the printed circuit board to the cabinet front (through fiber stand-offs).
4. Unsolder the black wire going from the radio battery holder contact (under clock case) to the printed circuit board chassis ground at the printed circuit board connection.
5. Remove the spade connector leads from the speaker, clock battery contact (positive side) and the printed circuit board terminal next to the audio output transformer (T5).
6. Remove the tuning knob and dial as follows. Slip a loop of string under the tuning dial and pull the dial and tuning knob up and out of the cabinet front.
7. Separate the printed circuit board chassis from the cabinet front. To operate the chassis it will be necessary to re-connect the speaker and radio battery leads.

Bottom view of printed circuit board with components shown symbolically.

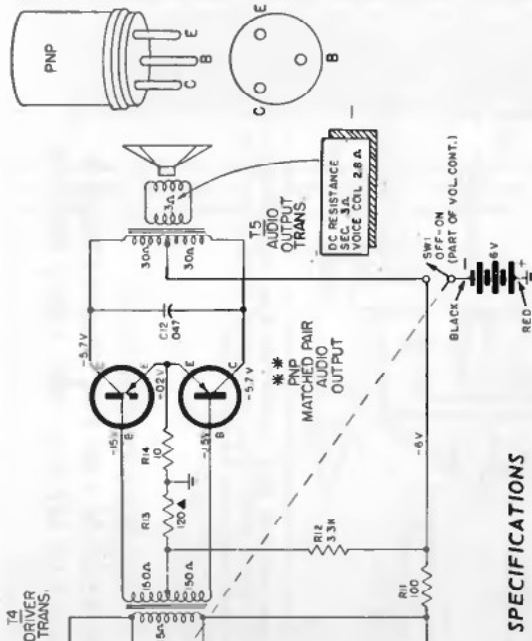

SPECIFICATIONS

Frequency Range 540 to 1600 KC
 Intermediate Frequency 455 KC
 Power Supply—6 volts (four 1.5 volt "C" batteries)
 No Signal Current Drain 9 ma

CHASSIS REMOVAL

1. Remove the volume control knob.
2. Remove the tuning control knob. Insert a loop of string under the tuning knob and pull the knob out of the cabinet front.
3. Remove the phillips head screw in the tuning control knob well.
4. Remove the back cover (loosen the two coin-slot screws).
5. Remove the two hex head screws securing the chassis to the cabinet.
6. Remove the chassis, with its battery holder, from the cabinet. The receiver can now be serviced. If it is necessary to also remove the speaker, then remove the two hex head screws securing the speaker and lift it out of its slot.
7. Use the reverse of the above steps to replace the chassis into the cabinet. If replaced, the mounting screw that is used in the tuning control knob well must be the same length as the original, so as to not damage the tuning capacitor.

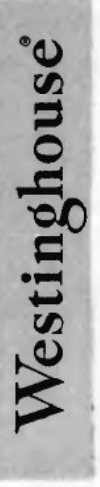

Model H-690P5, Chassis V-2397-1

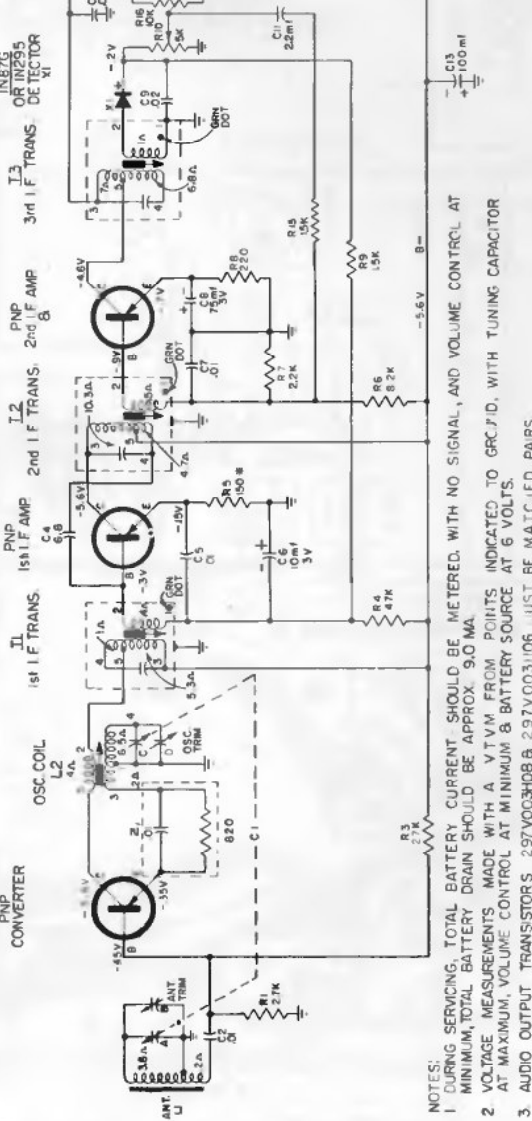

- NOTES:
1. DURING SERVICING, TOTAL BATTERY CURRENT SHOULD BE METERED. WITH NO SIGNAL, AND VOLUME CONTROL AT MINIMUM, TOTAL BATTERY DRAIN SHOULD BE APPROX. 9.0 MA.
 2. VOLTAGE MEASUREMENTS MADE WITH A .1 VTM FROM POINTS INDICATED TO GROUND, WITH TUNING CAPACITOR AT MAXIMUM, VOLUME CONTROL AT MINIMUM & BATTERY SOURCE AT 6 VOLTS.
 3. AUDIO OUTPUT TRANSISTORS 297V003/106 MUST BE MATCHED PAIRS.
 4. ALL CAPACITORS LESS THAN ONE ARE IN MFD, ALL CAPACITORS GREATER THAN ONE ARE IN MMFD, UNLESS OTHERWISE SPECIFIED. ALL RESISTORS ARE IN OHMS, 1/2 WATT.

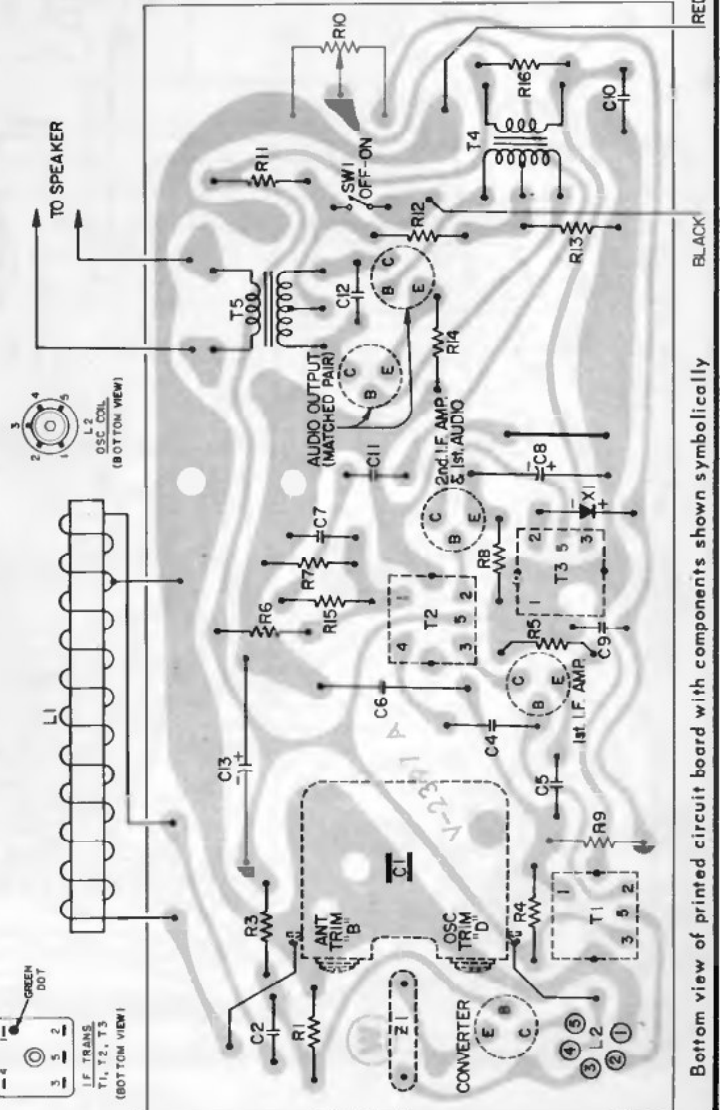

Bottom view of printed circuit board with components shown symbolically

WESTINGHOUSE
V-2502-5 AM-FM Tuner Chassis
 used in Models HR102S, HR103S.

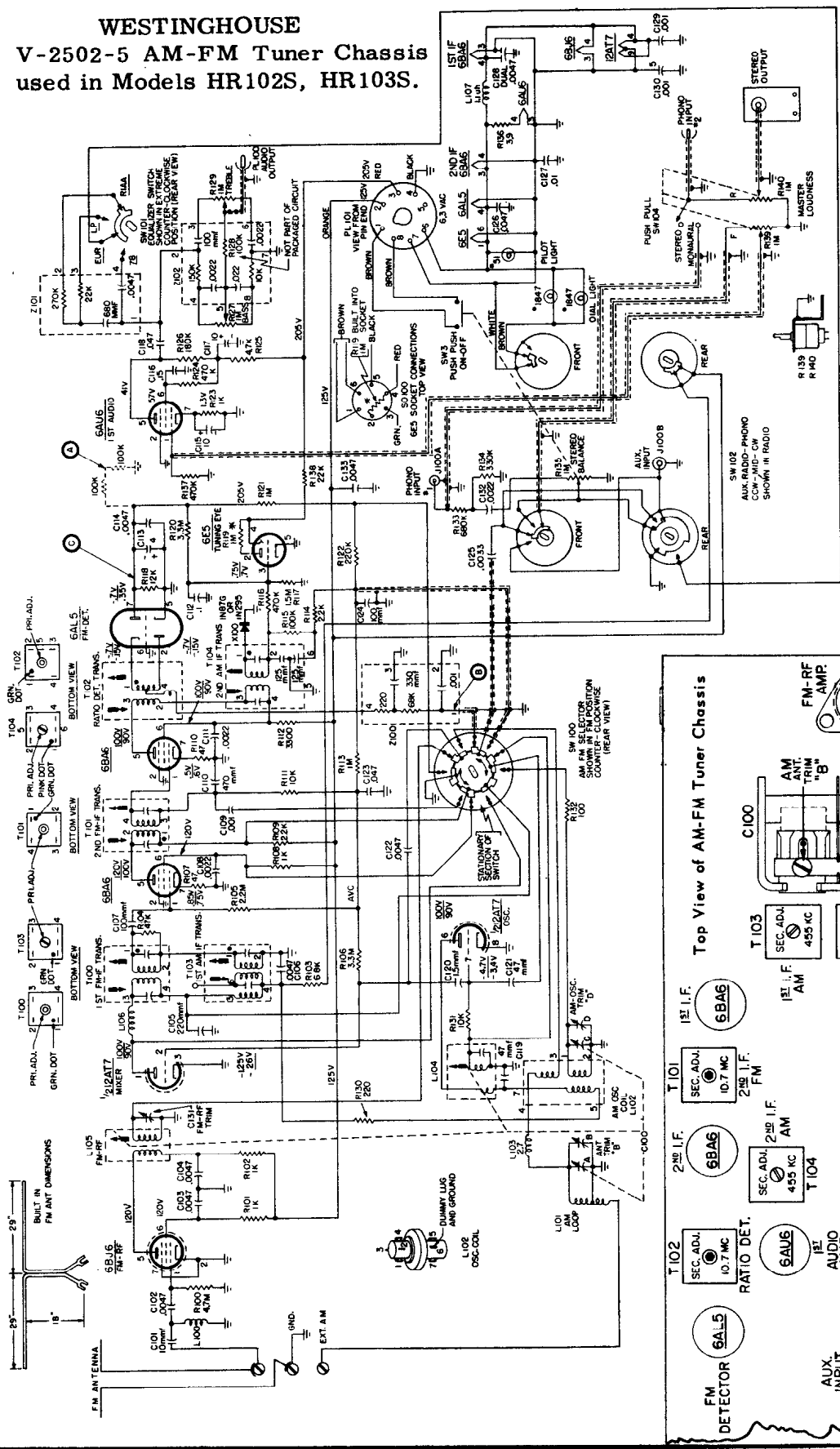

1. ALL CAPACITANCE VALUES IN MFD. AND ALL RESISTANCE VALUES IN OHMS UNLESS OTHERWISE SPECIFIED.
2. ALL VOLTAGE MEASURED TO CHASSIS USING A V.T.M. LINE VOLTAGE SET AT 117 VOLTS AC. VOLTAGES SHOULD BE AS SHOWN ± 20%. NO SIGNAL INPUT. LOUDNESS AT MINIMUM, TUNING CAPACITOR AT MAXIMUM.
3. POWER DERIVED FROM AMPLIFIER CHASSIS V2500-2.
4. * = BUILT IN 6E5 SOCKET.

WESTINGHOUSE
V-2502-5 AM-FM Tuner Chassis
 used in Models HR-102S, HR103S

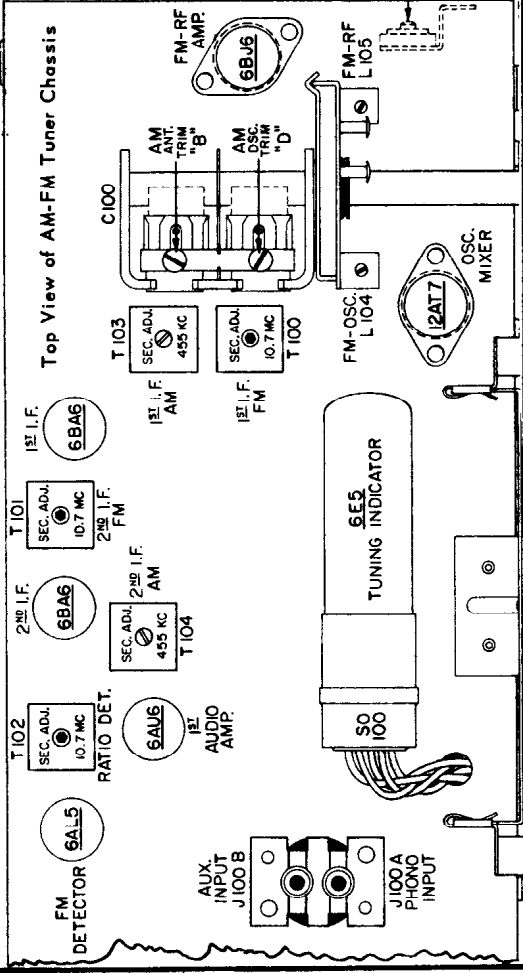

Westinghouse

Models HF-110AN, HF-111AN,
Chassis V-2503-2

1. ALL CAPACITANCE VALUES IN MFD AND ALL RESISTANCE VALUES IN OHMS UNLESS OTHERWISE SPECIFIED.
2. ALL VOLTAGES MEASURED TO B-USING A VTVM, LINE VOLTAGE SET AT 117V AC, VOLTAGES SHOULD BE AS SHOWN $\pm 20\%$, NO SIGNAL INPUT, LOUDNESS AT MINIMUM.

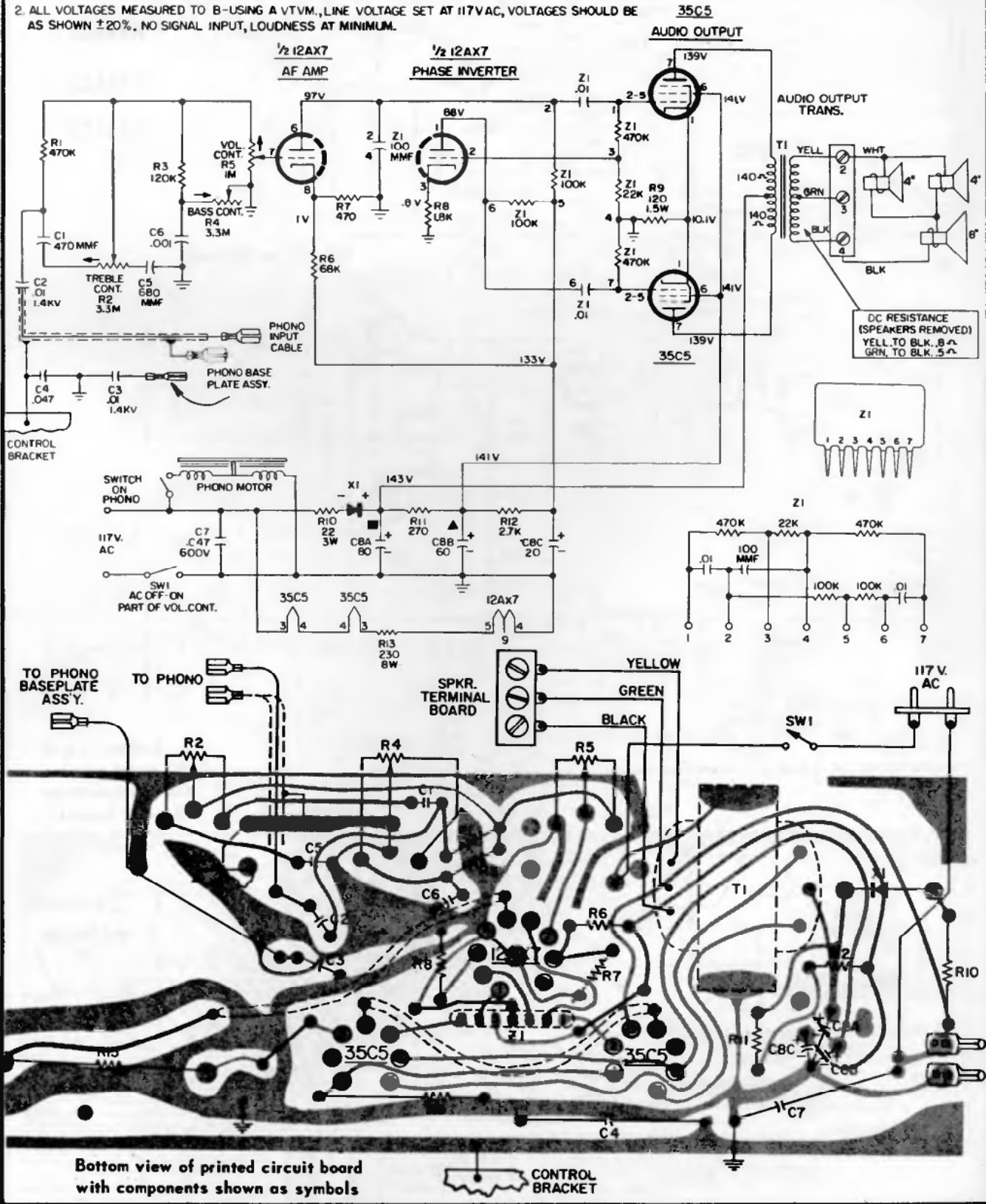



Models H-45AC1A, H-45AC2A,
Chassis V-2506-3

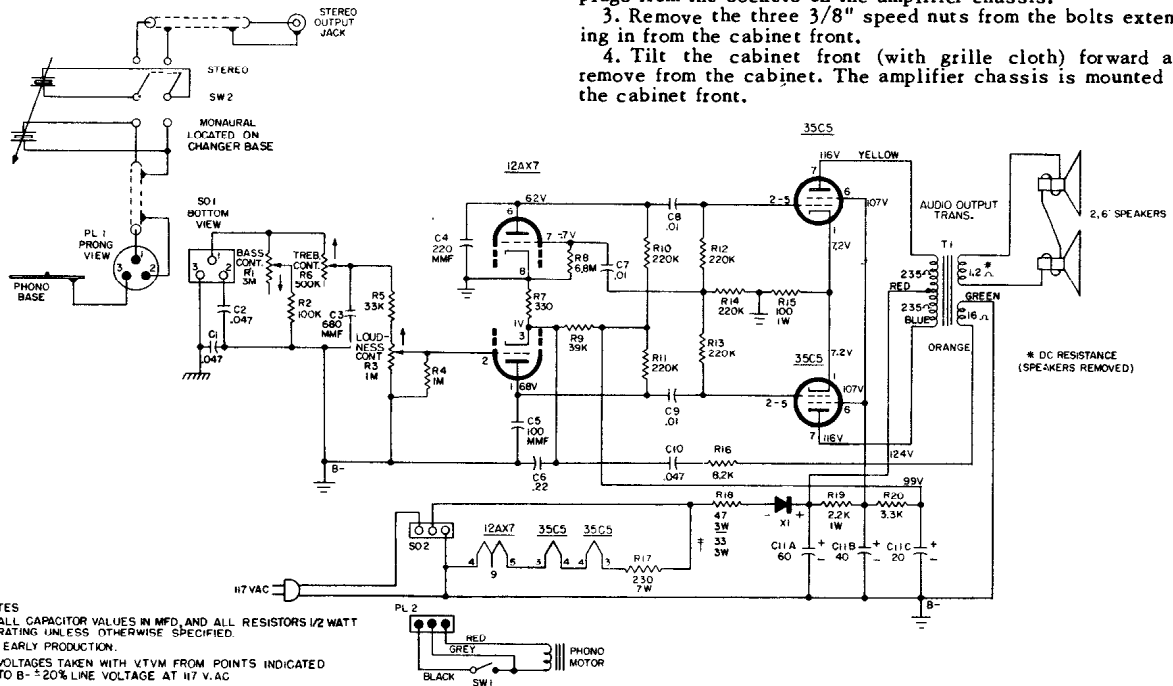

NOTES
 1 ALL CAPACITOR VALUES IN MFD, AND ALL RESISTORS 1/2 WATT RATING UNLESS OTHERWISE SPECIFIED.
 2 * EARLY PRODUCTION.
 3 VOLTAGES TAKEN WITH VTVM FROM POINTS INDICATED TO B- ± 20% LINE VOLTAGE AT 117 V.AC

TUBE REPLACEMENT

To replace the vacuum tubes it is first necessary to remove the cover at the rear of the speaker baffle. This cover has ventilating holes and is secured by two phillips-head screws.

CHASSIS REMOVAL

1. Remove the cover at the rear of the speaker baffle. This cover has ventilating holes and is secured by two phillips-head screws.
2. Remove the record changer mounting board. This is secured by four phillips-head screws, one in each corner of the board. Lift the board up and out of the cabinet. To completely detach the changer from the phonograph remove the two cable plugs from the sockets on the amplifier chassis.
3. Remove the three 3/8" speed nuts from the bolts extending in from the cabinet front.
4. Tilt the cabinet front (with grille cloth) forward and remove from the cabinet. The amplifier chassis is mounted on the cabinet front.

WESTINGHOUSE Models H-44AC1A, H-44AC2A, Chassis V-2506-2.

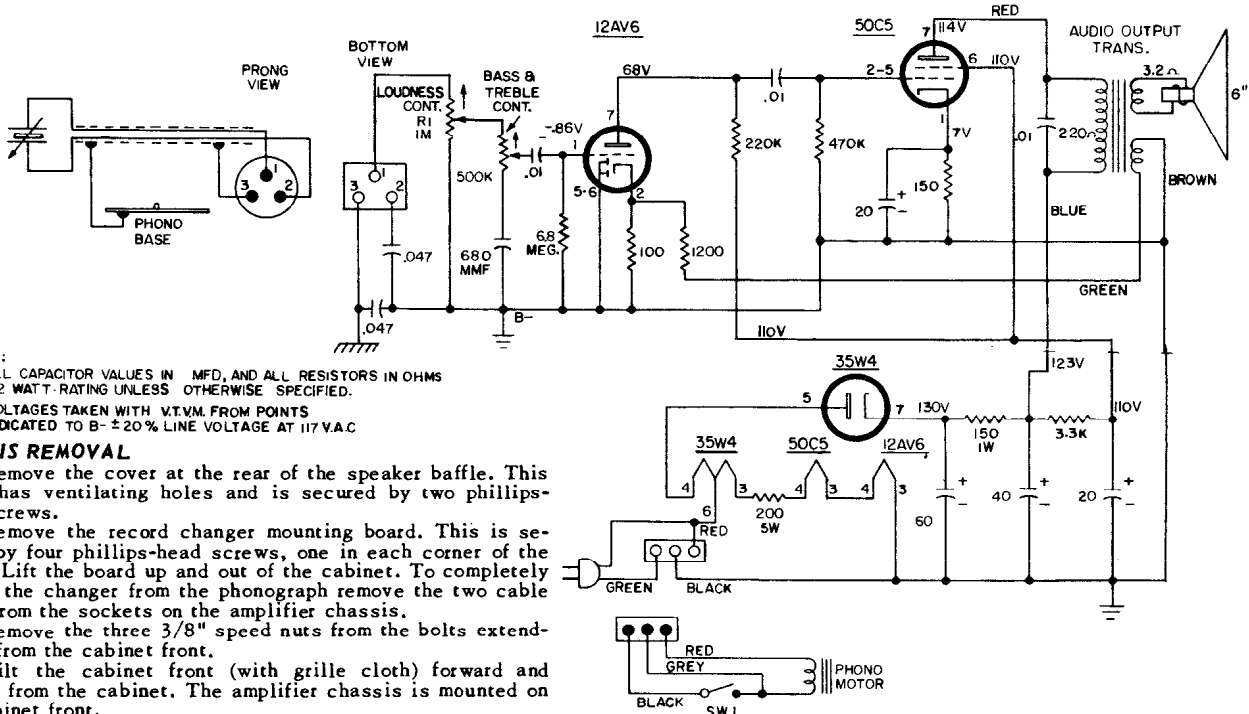

NOTE:
 1. ALL CAPACITOR VALUES IN MFD, AND ALL RESISTORS IN OHMS 1/2 WATT-RATING UNLESS OTHERWISE SPECIFIED.
 2. VOLTAGES TAKEN WITH VTVM FROM POINTS INDICATED TO B- ± 20% LINE VOLTAGE AT 117 V.AC

CHASSIS REMOVAL

1. Remove the cover at the rear of the speaker baffle. This cover has ventilating holes and is secured by two phillips-head screws.
2. Remove the record changer mounting board. This is secured by four phillips-head screws, one in each corner of the board. Lift the board up and out of the cabinet. To completely detach the changer from the phonograph remove the two cable plugs from the sockets on the amplifier chassis.
3. Remove the three 3/8" speed nuts from the bolts extending in from the cabinet front.
4. Tilt the cabinet front (with grille cloth) forward and remove from the cabinet. The amplifier chassis is mounted on the cabinet front.

Westinghouse

- MODELS**
- H48SE1 (mahogany)
 - H48SE2 (oak)
 - H48SE3 (fruitwood)
 - H48SE4 (walnut)
 - H48SE5 (tutone)

CHASSIS V-2503-5

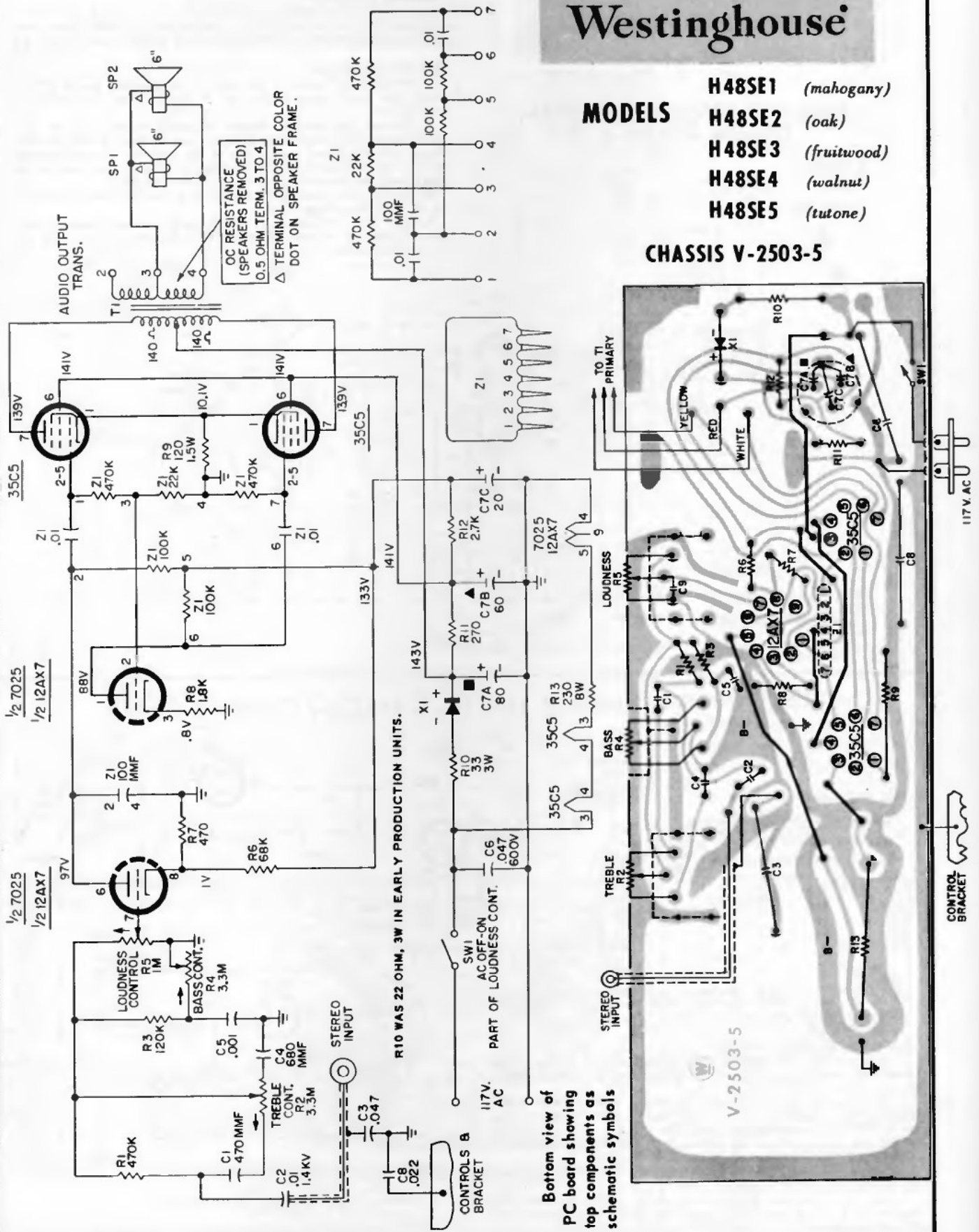

ZENITH RADIO CORP. MODELS SF174R & SF177E & R

CHASSIS 4B22, 4B23, 3B30

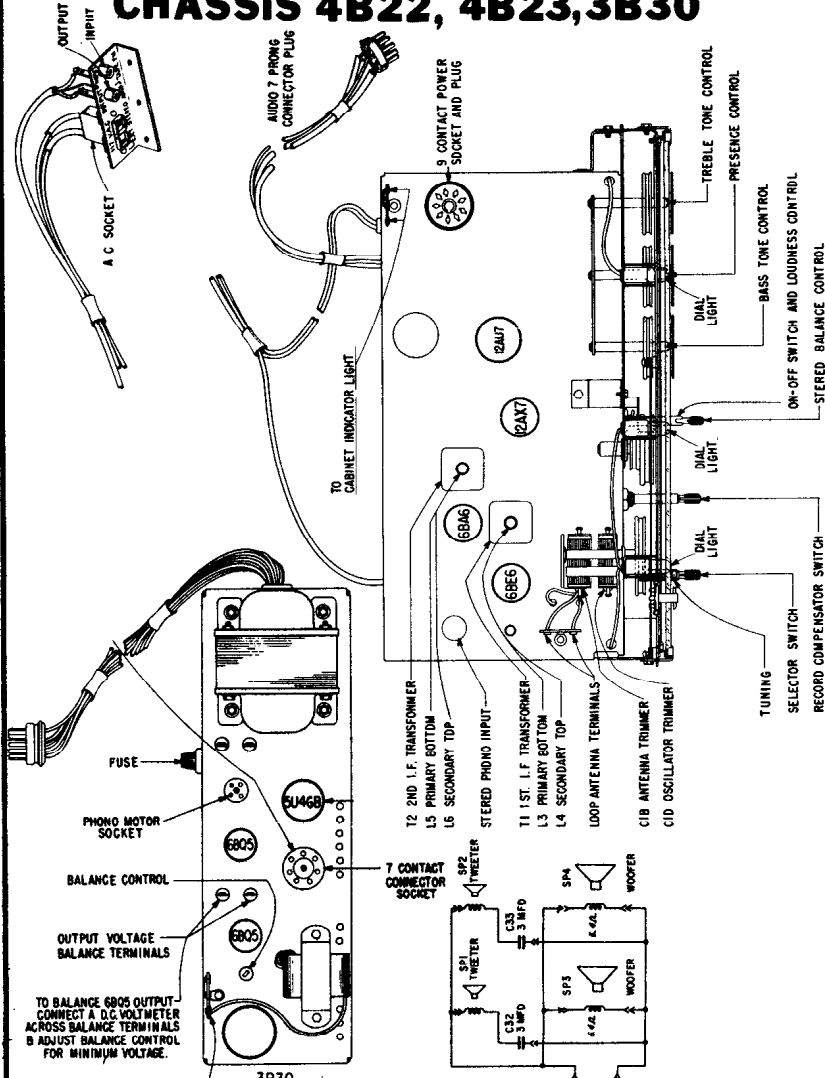

TUBE, TRIMMER LOCATION AND DETAILED VIEW OF I.F. TRANSFORMERS

ALIGNMENT PROCEDURE

| Operation | Connect Oscillator to Antenna | Dummy Antenna | Input Sig. Frequency | Set Dial at | Trimmers | Purpose |
|-----------|--|---------------|----------------------|-------------|----------------|--------------------------------|
| 1 | Converter Grid | .5 Mfd. | 455 Kc. | 600 Kc. | L3, L4, L5, L6 | Align I.F. for maximum output. |
| 2 | One turn Loop Coupled Loosely to Wave Magnet | - | 1600 Kc. | 1600 Kc. | C1D | Set Osc. to Dial Scale |
| 3 | | | 1400 Kc. | 1400 Kc. | C1B | Align Antenna Stage |

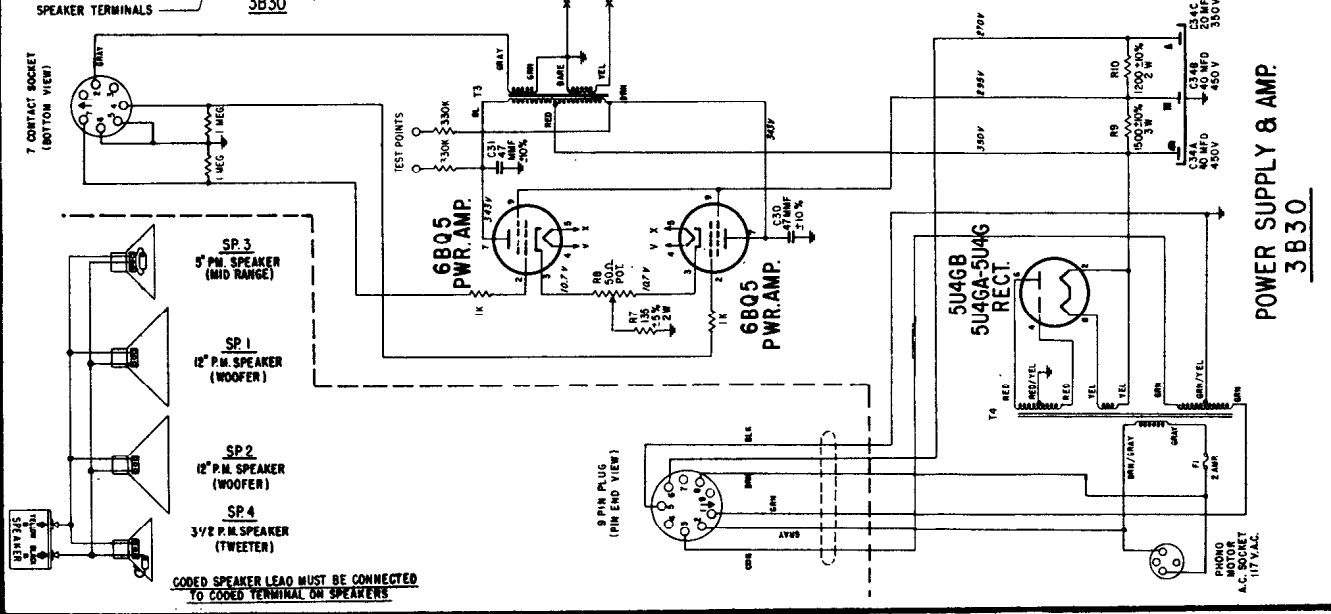

ZENITH RADIO CORPORATION MODEL SF112, CHASSIS 4B24-4B25 & REMOTE SPEAKER SRS2

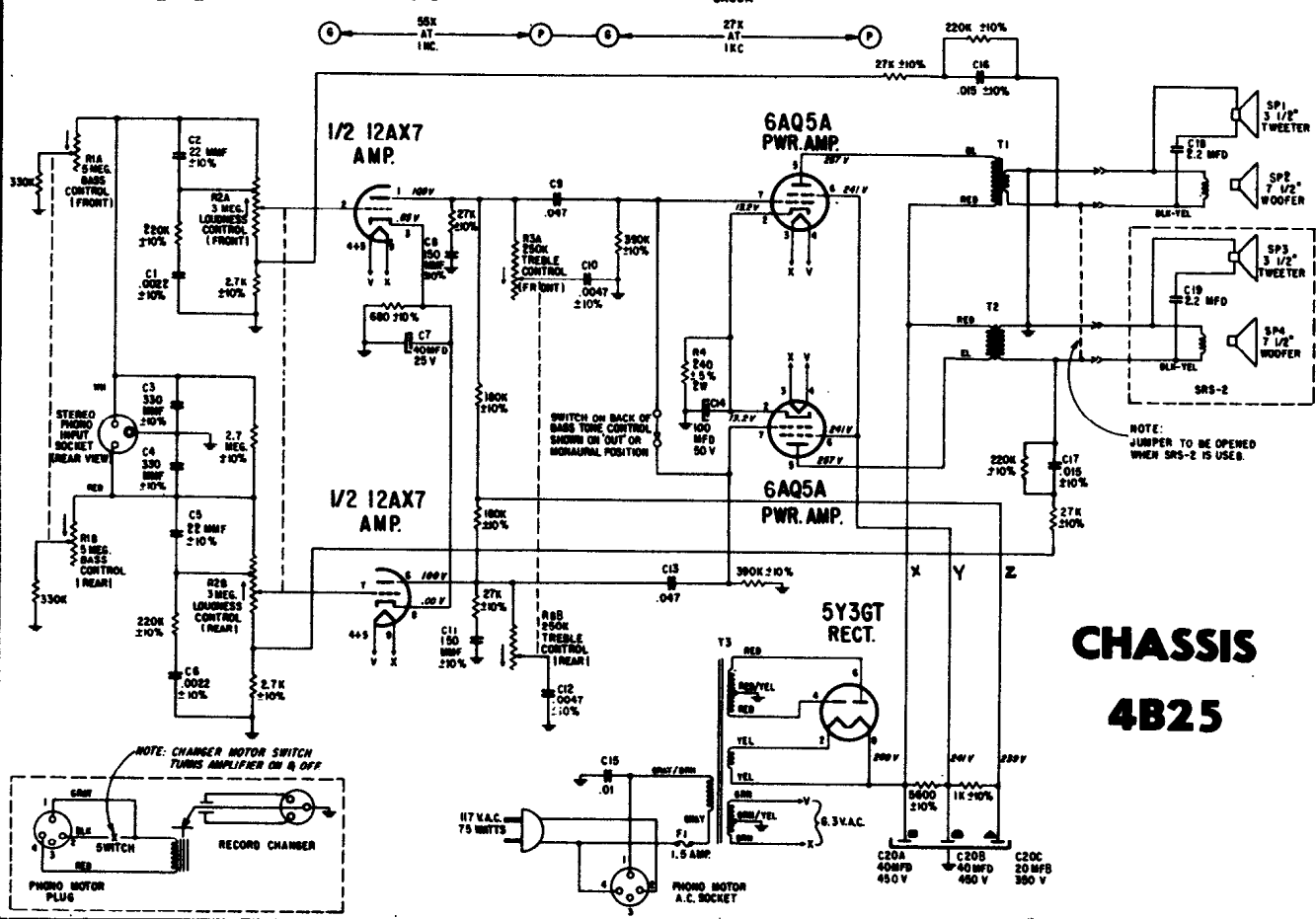
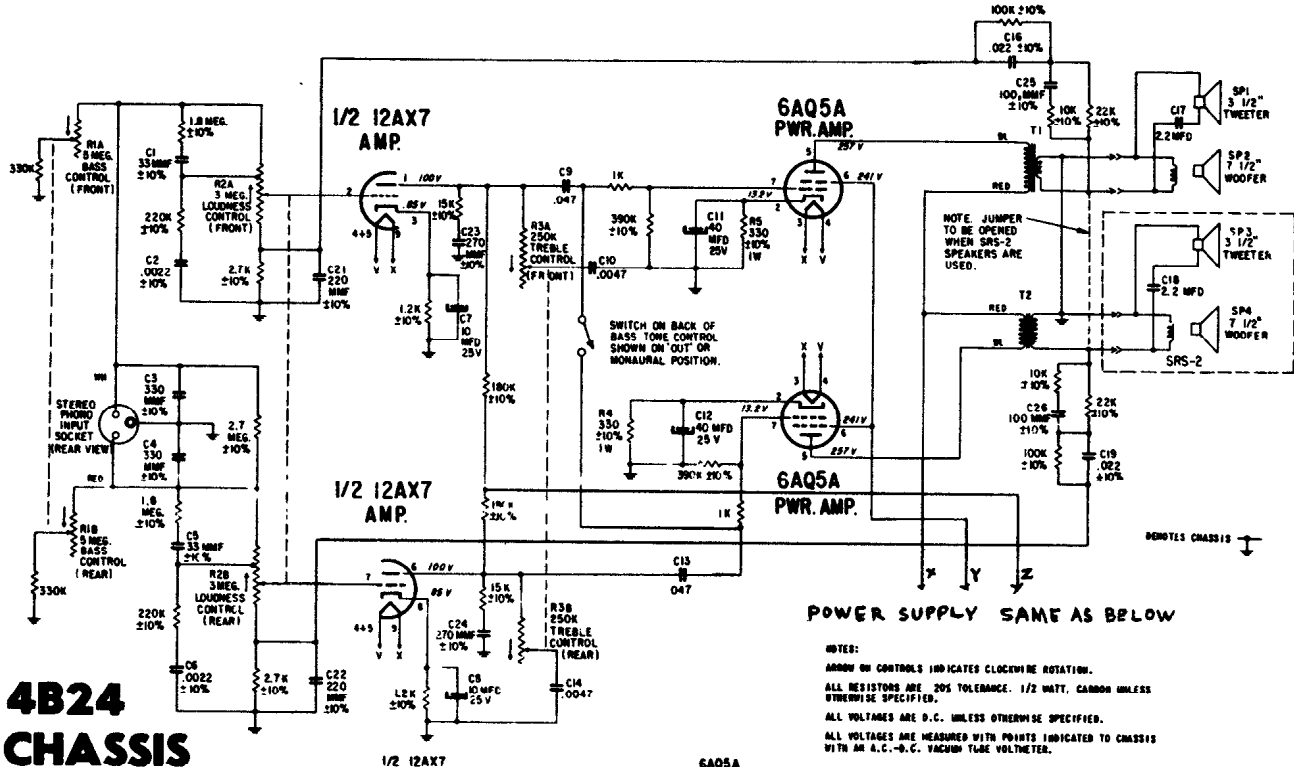

ZENITH RADIO CORPORATION MODEL B513Y, L, F, V, CHASSIS 5B01

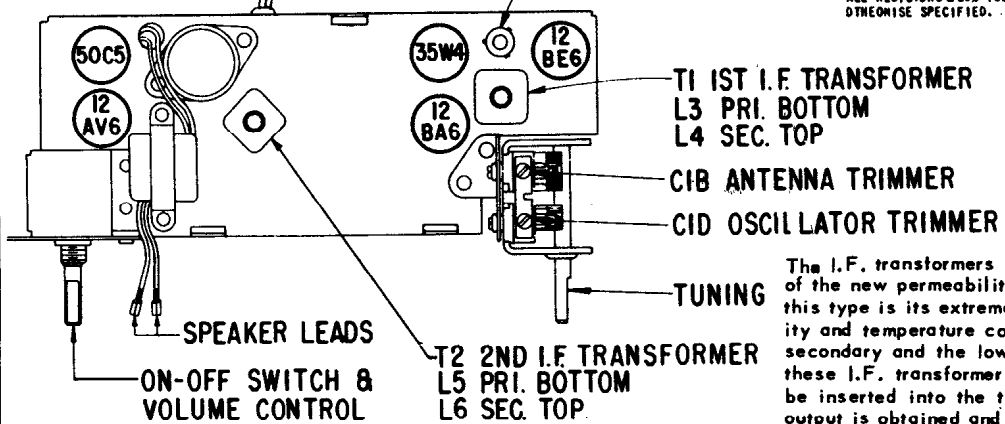
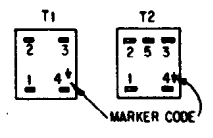
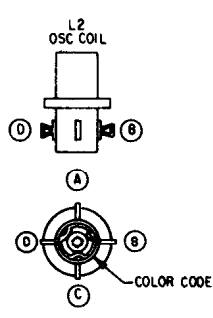
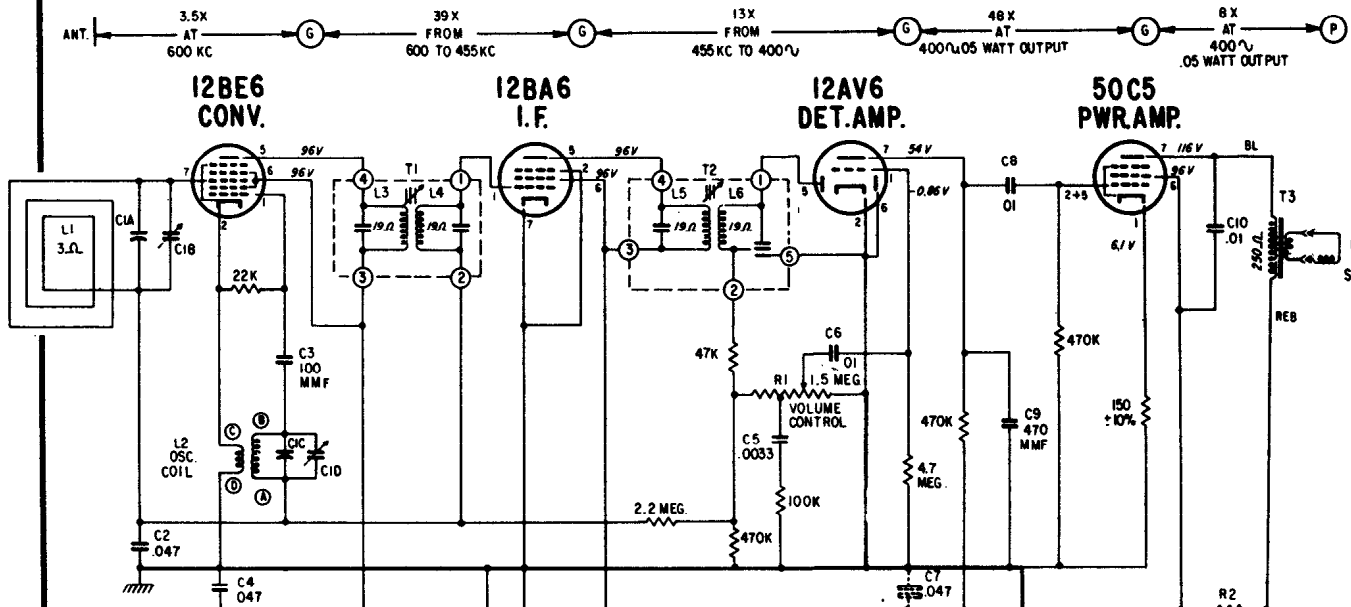

NOTES:
 ALL VOLTAGES MEASURED FROM COMMON RETURN TO POINTS INDICATED WITH AN A.C., D.C. OR VACUUM TUBE VOLTMETER.
 USE ONLY ZENITH NON-INDUCTIVE ELECTROLYTIC CONDENSERS FOR REPLACEMENT.
 IF ANY OTHER TYPE OF ELECTROLYTIC IS USED IT WILL BE NECESSARY TO ADD C7 SHOWN IN DOTTED LINES.
 I.F. TRANSFORMER NUMBERING STARTS WITH P1 TERMINAL AS FIRST TERMINAL CLOCKWISE FROM MARKER CODE TERMINAL AS VIEWED FROM BOTTOM OF CHASSIS.
 I.F. FREQUENCY 465 KC
 TUNING RANGE 535-1520 KC
 ALL RESISTORS ±20% TOLERANCE, 1/2 WATT, CARBON UNLESS OTHERWISE SPECIFIED.

The I.F. transformers incorporated in this receiver are of the new permeability tuned type. The advantage of this type is its extreme stability under various humidity and temperature conditions. The upper coil is the secondary and the lower the primary. When adjusting these I.F. transformers, the tuning wrench 68-19 can be inserted into the top slug, rotated until maximum output is obtained and then dropped down to the lower slug and the same operation repeated.

ALIGNMENT PROCEDURE

| OPERATION | CONNECT OSCILLATOR TO | DUMMY ANTENNA | INPUT SIG. FREQUENCY | SET DIAL AT | TRIMMERS | PURPOSE |
|-----------|---|---------------|----------------------|-------------|-------------|-----------------------------|
| 1 | Converter Grid | .5 Mfd. | 455 Kc. | 600 Kc. | L3,L4,L5,L6 | Align I.F. for max. output. |
| 2 | One Turn Loop Coupled Loosely to Wave Magnet. | - | 1600 Kc. | 1600 Kc. | C1D | Set Osc. to Dial Scale. |
| 3 | | - | 1400 Kc. | 1400 Kc. | C1B | Align Antenna Stage. |

VOLUME R-19, MOST-OFTEN-NEEDED 1959 RADIO SERVICING INFORMATION

ZENITH RADIO CORP MODELS B514F,W,C,V-B515B,P,G,Y CHASSIS 5B04-5B06

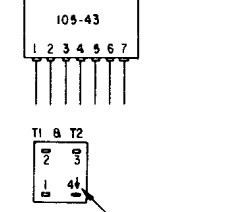
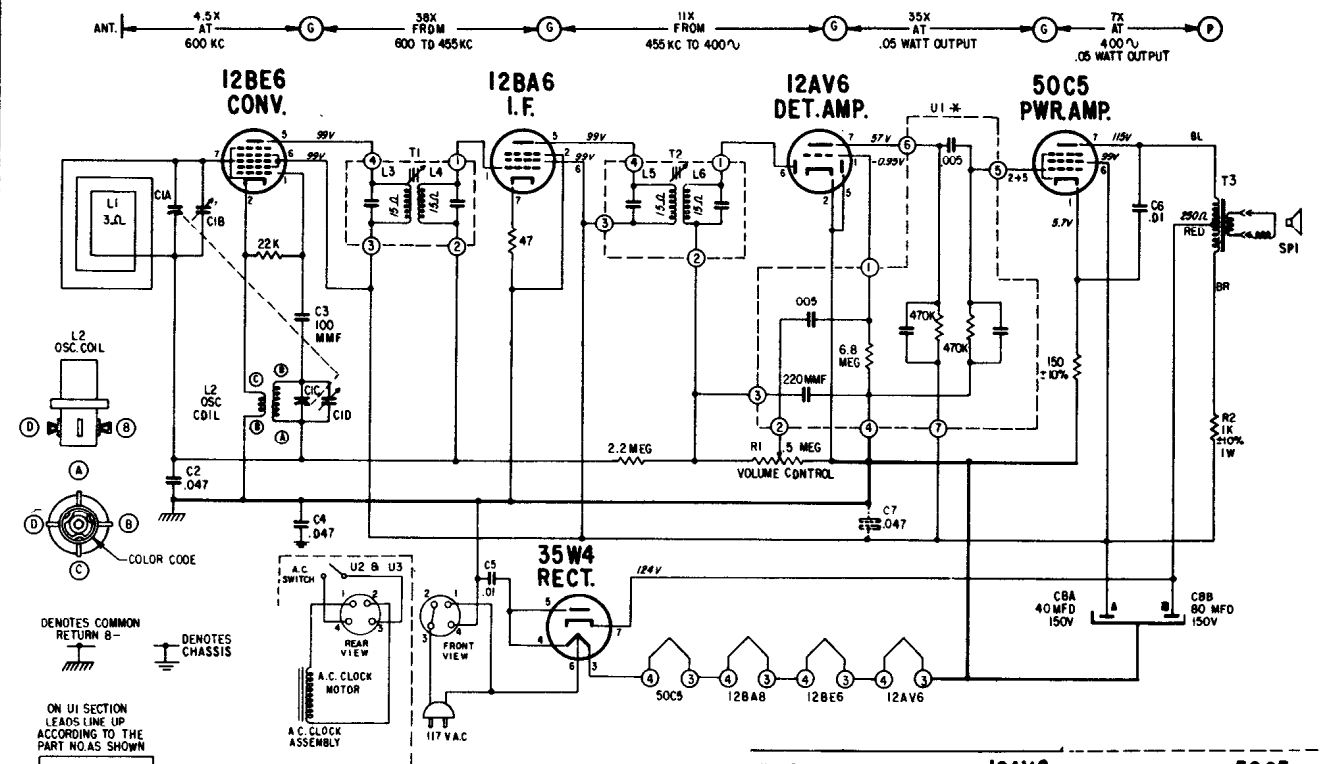

NOTES:
 ALL VOLTAGES MEASURED FROM COMMON RETURN TO POINTS INDICATED WITH AN A.C., D.C. OR VACUUM TUBE VOLTMETER.
 USE ONLY ZENITH NON-INDUCTIVE ELECTROLYTIC CONDENSERS FOR REPLACEMENT.
 IF ANY OTHER TYPE OF ELECTROLYTIC IS USED IT WILL BE NECESSARY TO ADD C7 SHOWN IN DOTTED LINES.
 I.F. TRANSFORMER NUMBERING STARTS WITH #1 TERMINAL AS FIRST TERMINAL CLOCKWISE FROM MARKER CODE TERMINAL AS VIEWED FROM BOTTOM OF CHASSIS.
 I.F. FREQUENCY 455 KC
 TUNING RANGE 535-1620 KC
 ALL RESISTORS ±20% TOLERANCE, 1/2 WATT, CARBON UNLESS OTHERWISE SPECIFIED.

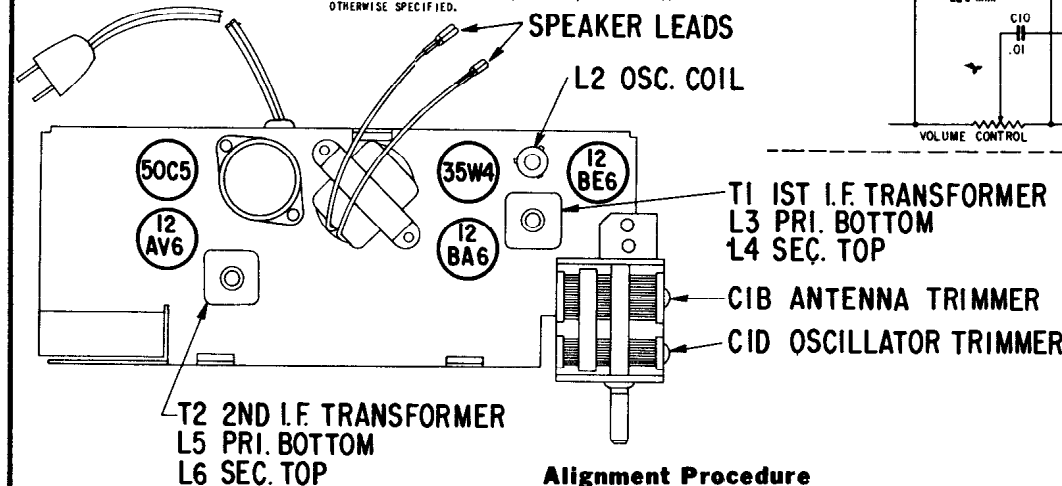
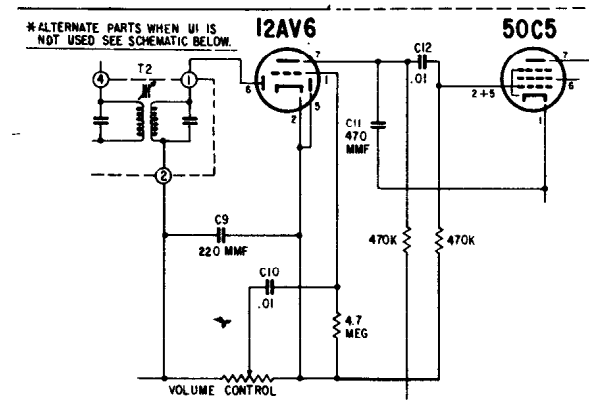

Alignment Procedure

| OPERATION | CONNECT OSCILLATOR TO | DUMMY ANTENNA | INPUT SIG. FREQUENCY | SET DIAL AT | TRIMMERS | PURPOSE |
|-----------|--|---------------|----------------------|-------------|-------------|------------------------------|
| 1 | Converter Grid | .5 Mfd. | 455 Kc. | 600 Kc. | L3, 4, 5, 6 | For I.F. Alignment. |
| 2 | One Turn Loop Coupled Loosely to Wave Magnet | — | 1600 Kc. | 1600 Kc. | CID | Set Oscillator to Dial Scale |
| 3 | | — | 1400 Kc. | 1400 Kc. | C1B | Align Antenna Stage |

VOLUME R-19, MOST-OFTEN-NEEDED 1959 RADIO SERVICING INFORMATION

ZENITH RADIO CORPORATION MODELS B509C, P, V, F, CHASSIS 5B11.
 MODELS B511 B, P, L, V, CHASSIS 5B10, are electrically the same.

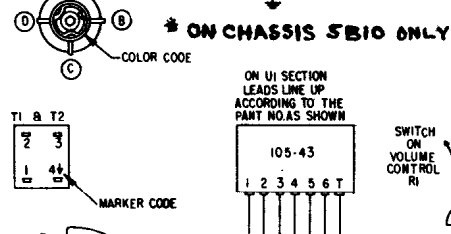
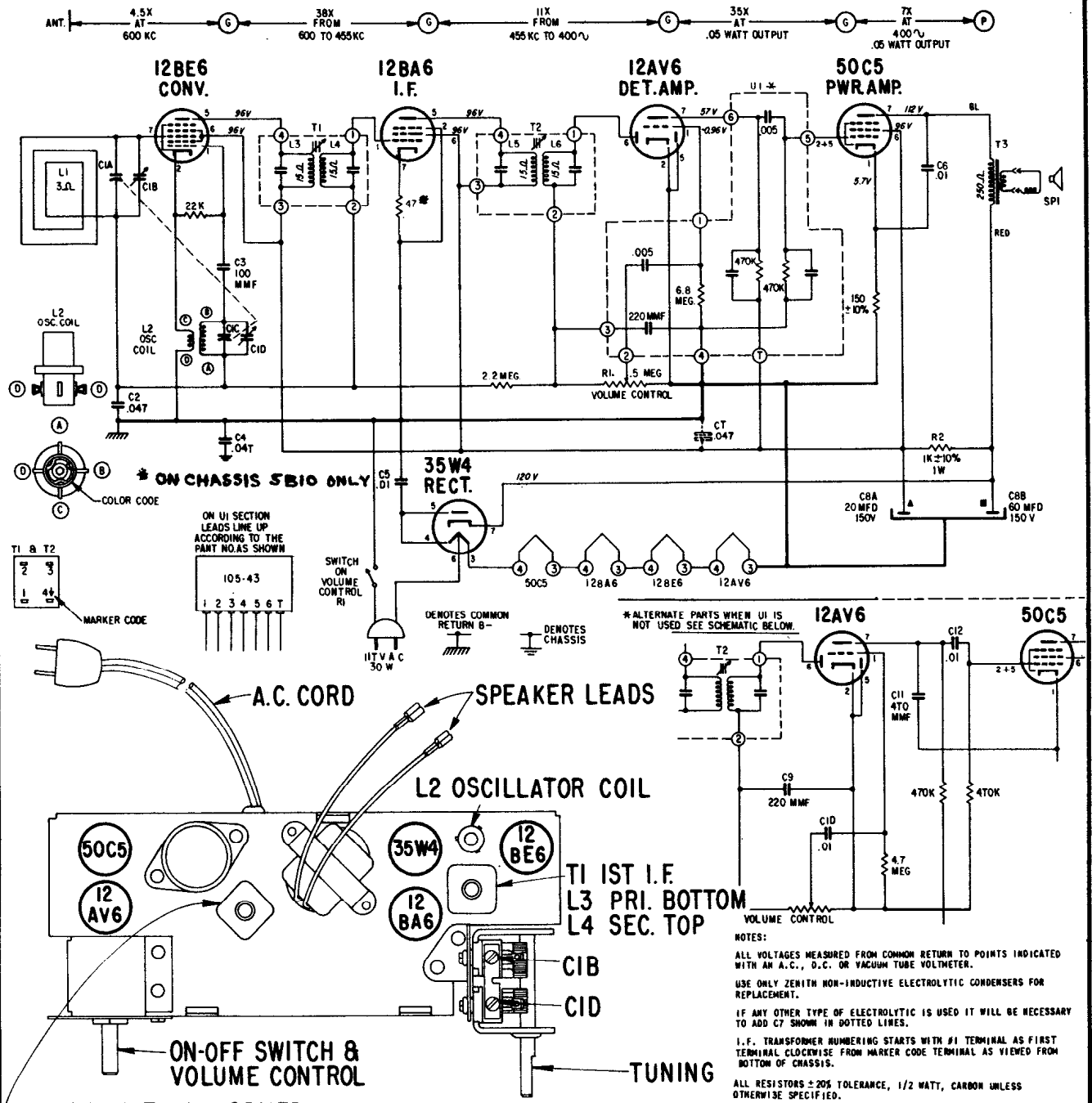

*ALTERNATE PARTS WHEN U1 IS NOT USED SEE SCHEMATIC BELOW.

NOTES:
 ALL VOLTAGES MEASURED FROM COMMON RETURN TO POINTS INDICATED WITH AN A.C., D.C. OR VACUUM TUBE VOLTMETER.
 USE ONLY ZENITH NON-INDUCTIVE ELECTROLYTIC CONDENSERS FOR REPLACEMENT.
 IF ANY OTHER TYPE OF ELECTROLYTIC IS USED IT WILL BE NECESSARY TO ADD C7 SHOWN IN DOTTED LINES.
 I.F. TRANSFORMER NUMBERING STARTS WITH #1 TERMINAL AS FIRST TERMINAL CLOCKWISE FROM MARKER CODE TERMINAL AS VIEWED FROM BOTTOM OF CHASSIS.
 ALL RESISTORS ±20% TOLERANCE, 1/2 WATT, CARBON UNLESS OTHERWISE SPECIFIED.

ALIGNMENT PROCEDURE

| Operation | Connect Oscillator To | Dummy Antenna | Input Sig. Frequency | Set Dial At | Trimmers | Purpose |
|-----------|--|---------------|----------------------|-------------|----------------|------------------------------|
| 1 | Converter Grid | .5 Mfd. | 455 Kc. | 600 Kc. | L3, L4, L5, L6 | For I.F. Alignment. |
| 2 | One Turn Loop Coupled Loosely to Wave Magnet | — | 1600 Kc. | 1600 Kc. | C1D | Set Oscillator to Dial Scale |
| 3 | — | — | 1400 Kc. | 1400 Kc. | C1B | Align Antenna Stage |

ZENITH RADIO CORPORATION

MODELS HF116E & HF116R

CHASSIS 5B20

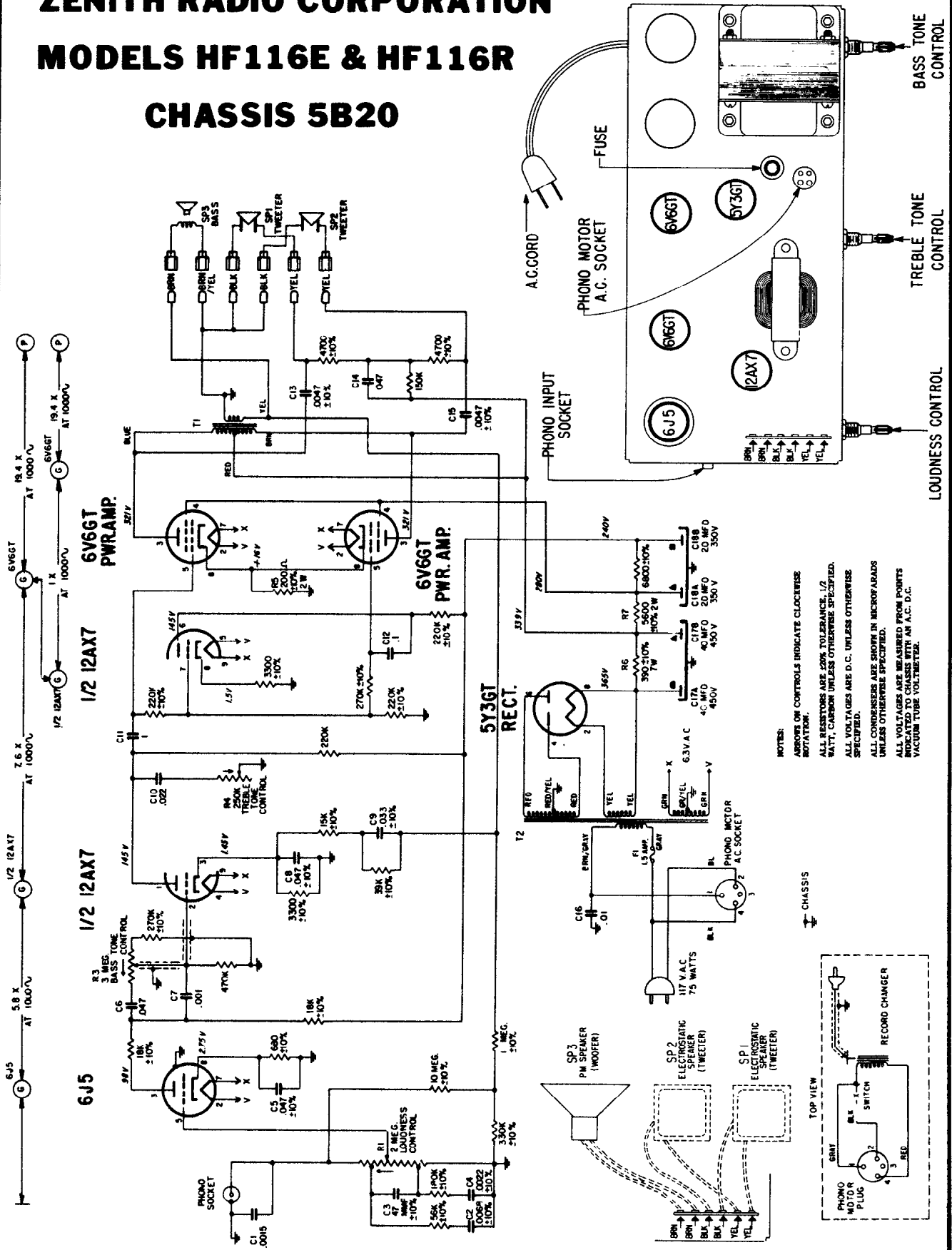

NOTES:
 ARROWS ON CONTROLS INDICATE CLOCKWISE ROTATION.
 ALL RESISTORS ARE 20% TOLERANCE, 1/2 WATT, CARBON UNLESS OTHERWISE SPECIFIED.
 ALL CAPACITORS ARE D.C. UNLESS OTHERWISE SPECIFIED.
 ALL CONDENSERS ARE SHOWN IN MICROFARADS UNLESS OTHERWISE SPECIFIED.
 ALL VOLTAGES ARE MEASURED FROM POINTS INDICATED BY ARROWS AT A.C. D.C. VACUUM TUBE VOLTMETER.

ZENITH RADIO CORP. MODELS HF117 & HF118 CHASSIS 5B22

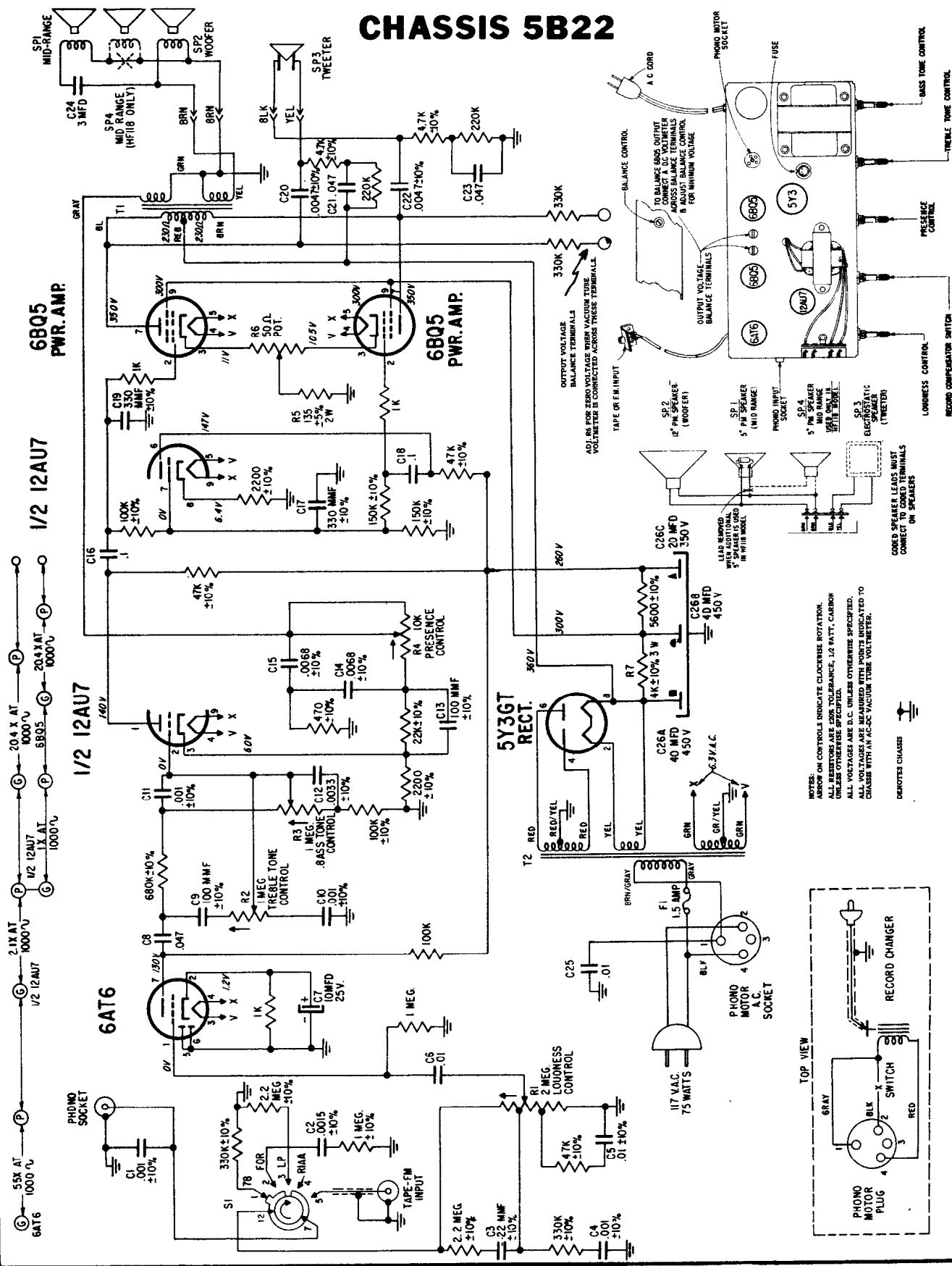

NOTES:
 ARROW ON CONTROLS INDICATE CLOCKWISE ROTATION.
 ALL RESISTORS ARE 20% TOLERANCE, 1/2 WATT, CARBON
 UNLESS OTHERWISE SPECIFIED.
 ALL CAPACITORS ARE 5% TOLERANCE UNLESS OTHERWISE SPECIFIED.
 ALL HOLES ARE TO BE DRILLED WITH DIMENSIONS INDICATED TO
 CHASSIS WITH AN AC-DC VACUUM TUBE VOLT-METER.

DIKOTES CHASSIS

ZENITH RADIO CORPORATION

MODELS SRS10 & SRS15

CHASSIS 5B24

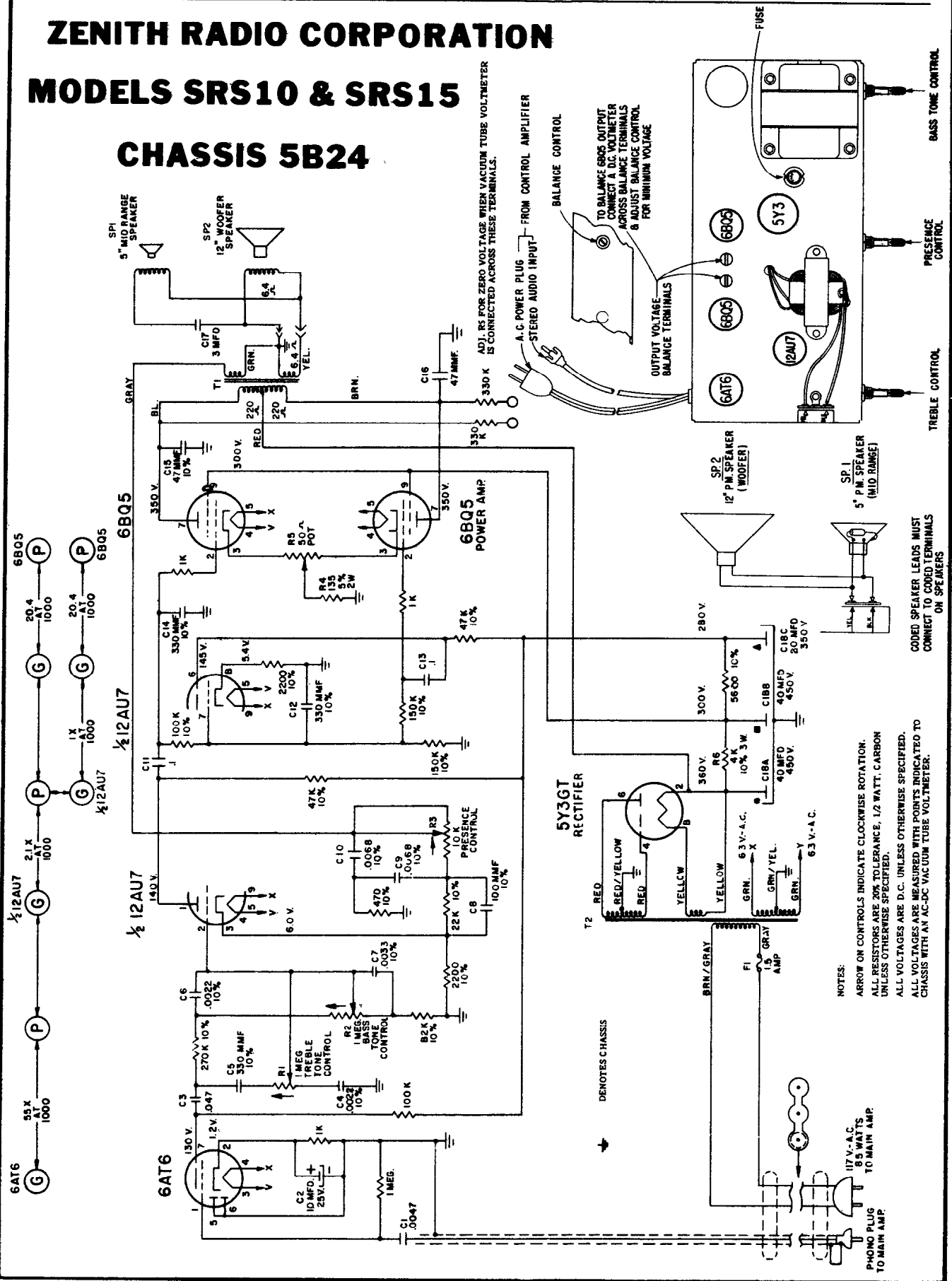

NOTES:
 ARROW ON CONTROLS INDICATE CLOCKWISE ROTATION.
 ALL RESISTORS ARE 20% TOLERANCE, 1/2 WATT, CARBON UNLESS OTHERWISE SPECIFIED.
 ALL VOLTAGES ARE D.C. UNLESS OTHERWISE SPECIFIED.
 ALL VOLTAGES ARE MEASURED WITH POINTS INDICATED TO CHASSIS WITH AN AC-DC VACUUM TUBE VOLTMETER.

CODED SPEAKER LEADS MUST CONNECT TO CODED TERMINALS ON SPEAKERS

ADJ. R5 FOR ZERO VOLTAGE WHEN VACUUM TUBE VOLTMETER IS CONNECTED ACROSS THESE TERMINALS.

TO BALANCE GROSS OUTPUT CONNECT DC VOLTMETER ACROSS BALANCE TERMINALS & ADJUST BALANCE CONTROL FOR MINIMUM VOLTAGE

PHONO PLUG TO MAIN AMP.
 117 V.-A.C. 85 WATTS TO MAIN AMP.

ZENITH RADIO CORPORATION MODELS B615L, F, G CHASSIS 6B05

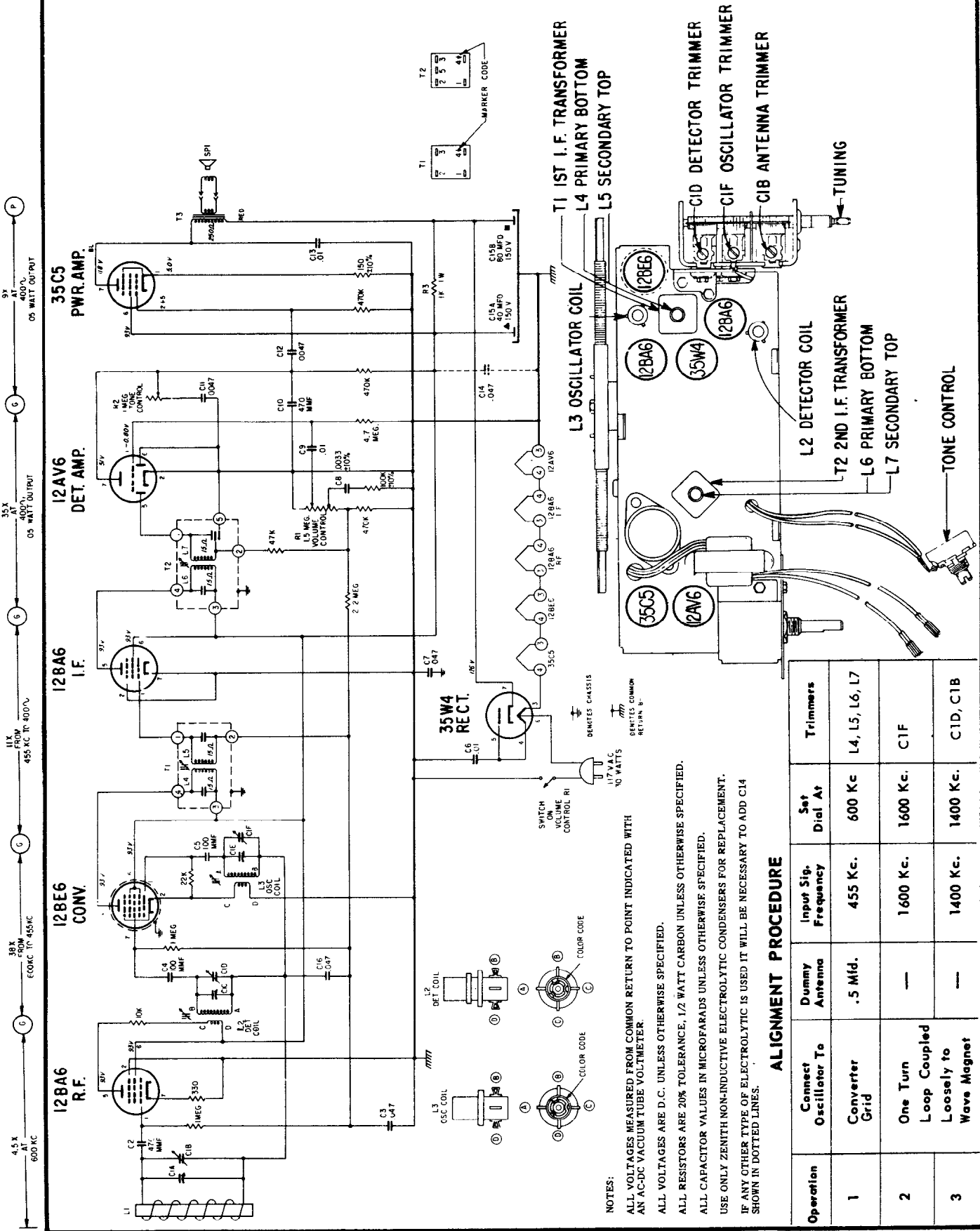

NOTES:
 ALL VOLTAGES MEASURED FROM COMMON RETURN TO POINT INDICATED WITH AN AC-DC VACUUM TUBE VOLTMETER.
 ALL VOLTAGES ARE D.C. UNLESS OTHERWISE SPECIFIED.
 ALL RESISTORS ARE 20% TOLERANCE, 1/2 WATT CARBON UNLESS OTHERWISE SPECIFIED.
 ALL CAPACITOR VALUES IN MICROFARADS UNLESS OTHERWISE SPECIFIED.
 USE ONLY ZENITH NON-INDUCTIVE ELECTROLYTIC CONDENSERS FOR REPLACEMENT.
 IF ANY OTHER TYPE OF ELECTROLYTIC IS USED IT WILL BE NECESSARY TO ADD C14 SHOWN IN DOTTED LINES.

ALIGNMENT PROCEDURE

| Operation | Connect Oscillator To | Dummy Antenna | Input Sig. Frequency | Set Dial At | Trimmers |
|-----------|--|---------------|----------------------|-------------|----------------|
| 1 | Converter Grid | .5 Mfd. | 455 Kc. | 600 Kc. | L4, L5, L6, L7 |
| 2 | One Turn Loop Coupled Loosely to Wave Magnet | — | 1600 Kc. | 1600 Kc. | C1F |
| 3 | — | — | 1400 Kc. | 1400 Kc. | C1D, C1B |

Zenith Radio Corporation Model HF660, Chassis 6B06

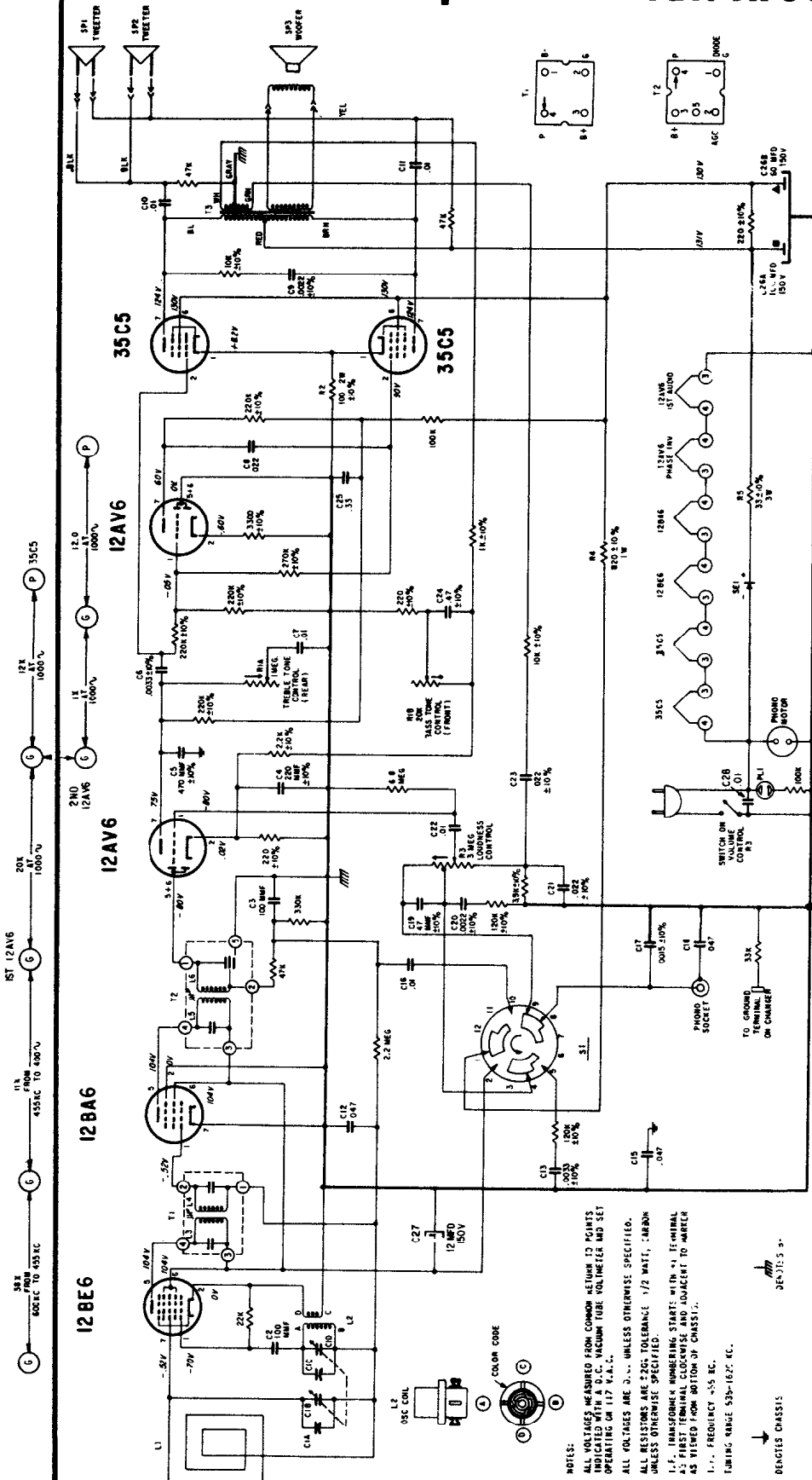

The I. F. transformers incorporated in this receiver are of the new permeability tuned type. The advantage of an I.F. transformer of this type is its extreme stability under various humidity and temperature conditions. The upper coil is the secondary and the lower the primary. When adjusting these I.F. transformers, the tuning wrench 6B-19 can be inserted into the top slug, rotated until maximum output is obtained and then dropped down to the lower slug and the same operation repeated. The tuning wrench is so designed that turning one slug does not affect the adjustment of the other.

ALIGNMENT PROCEDURE

| OPERATION | CONNECT DUMMY DISCLLATOR TO ANTENNA | INPUT SIG. FREQUENCY | SET DIAL AT | TRIMMERS | PURPOSE |
|-----------|--|----------------------|-------------|----------------|-------------------------------|
| 1 | Converter Grid | 455 Kc. | 600 Kc. | L3, L4, L5, L6 | Align I.F. for maximum output |
| 2 | One Turn Loop Coupled Loosely to Wave Magnet | 1600 Kc. | 1600 Kc. | C1D | Set Oscillator to Dial Scale. |
| 3 | | 1400 Kc. | 1400 Kc. | C1B | Align Antenna Stage |

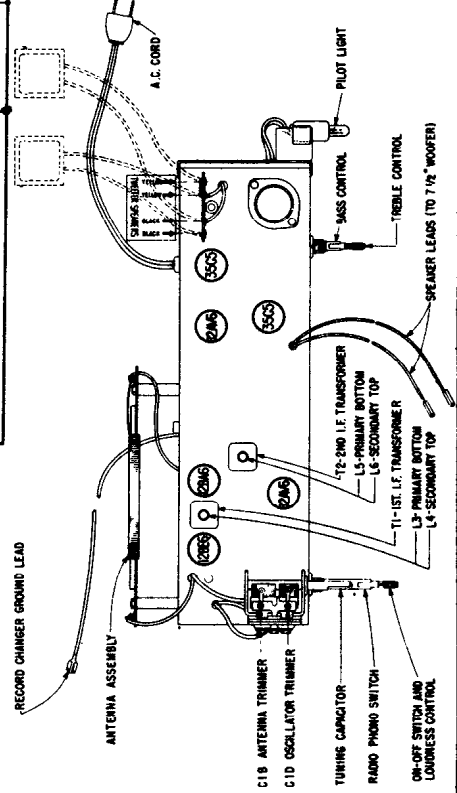

NOTES:
 ALL VOLTAGES MEASURED FROM COMMON RETURN TO POINTS INDICATED WITH A D.C. VACUUM TUBE VOLTMETER AND SET OPERATING ON 117 V.A.C.
 ALL VOLTAGES ARE D.C. UNLESS OTHERWISE SPECIFIED.
 ALL RESISTORS ARE 5% TOLERANCE 1/2 WATT, CARBON UNLESS OTHERWISE SPECIFIED.
 I.F. TRANSFORMERS WINDINGS START AT PIN 1 TERMINAL A; FIRST TERMINAL CLOCKWISE AND ADJACENT TO NUMBER AS VIEWED FROM BOTTOM OF CHASSIS.
 I.F. FREQUENCY 455 KC.
 TUNING RANGE 530-1627 KC.

ZENITH RADIO CORPORATION

MODELS BP6B, L, V

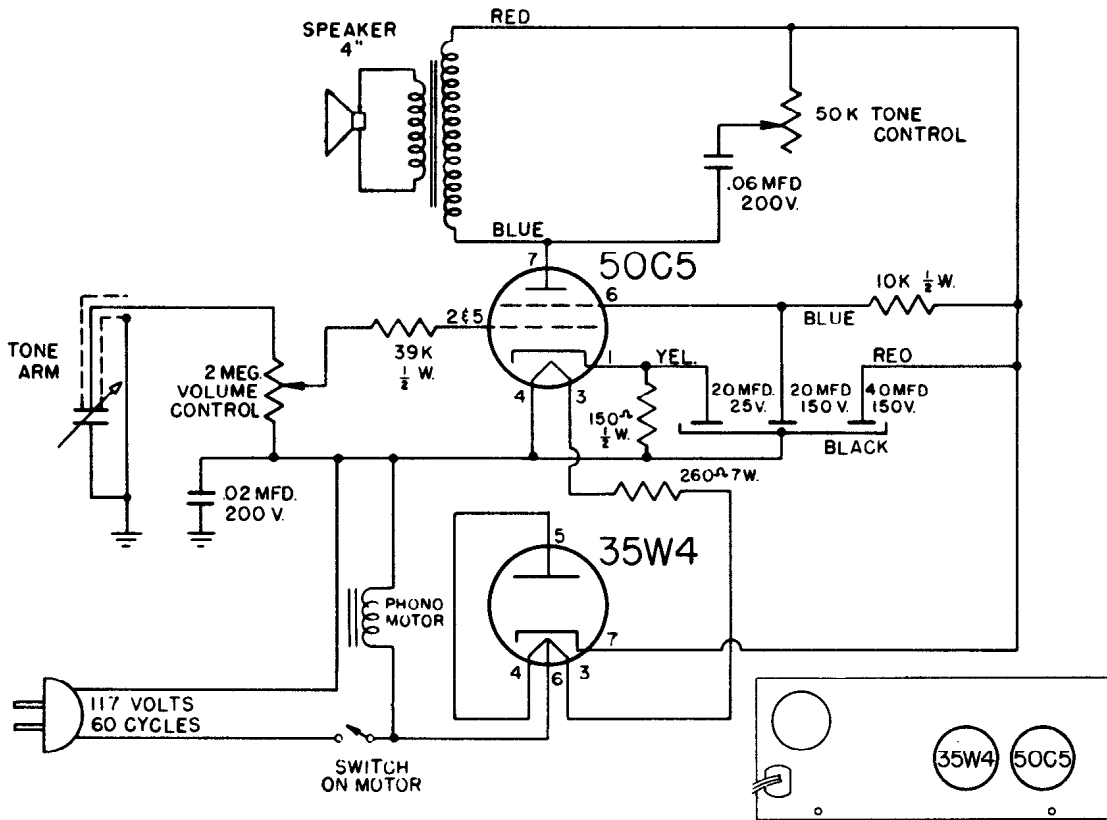

MODEL BP7F

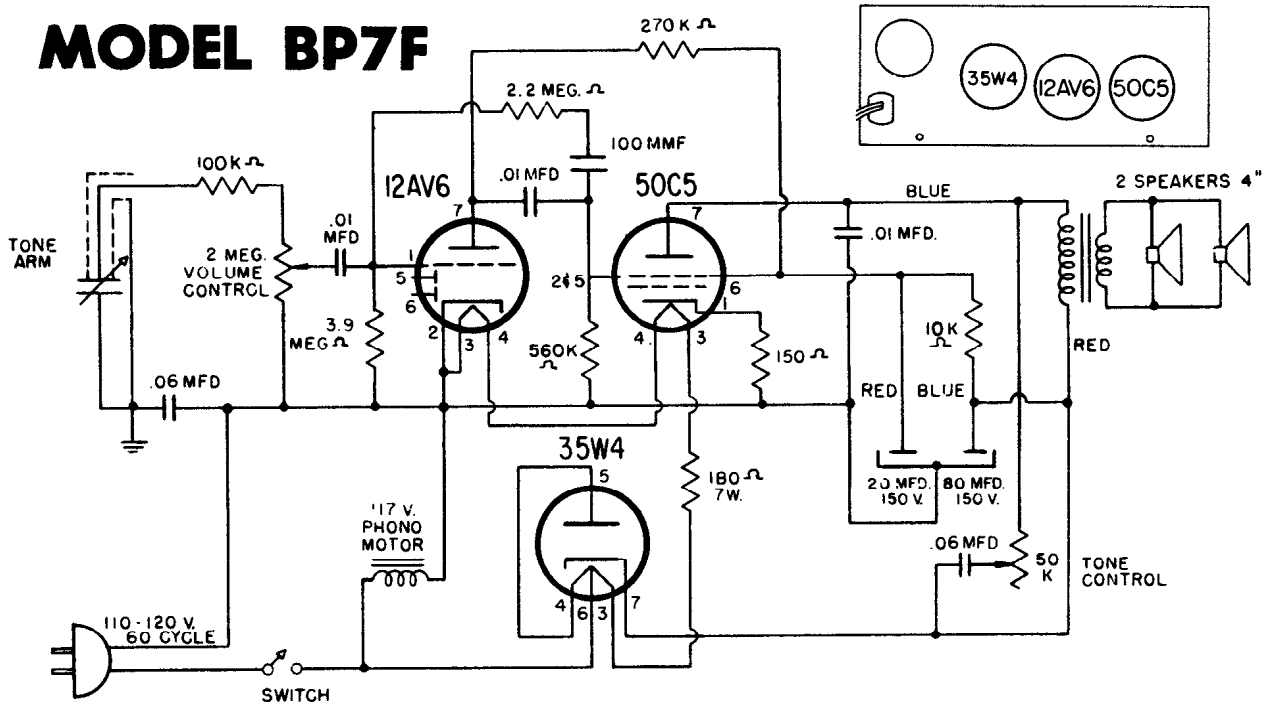

ZENITH RADIO CORPORATION

MODEL B728C, F & W, CHASSIS 7A03

(For alignment and additional data see page 183, adjacent at right)

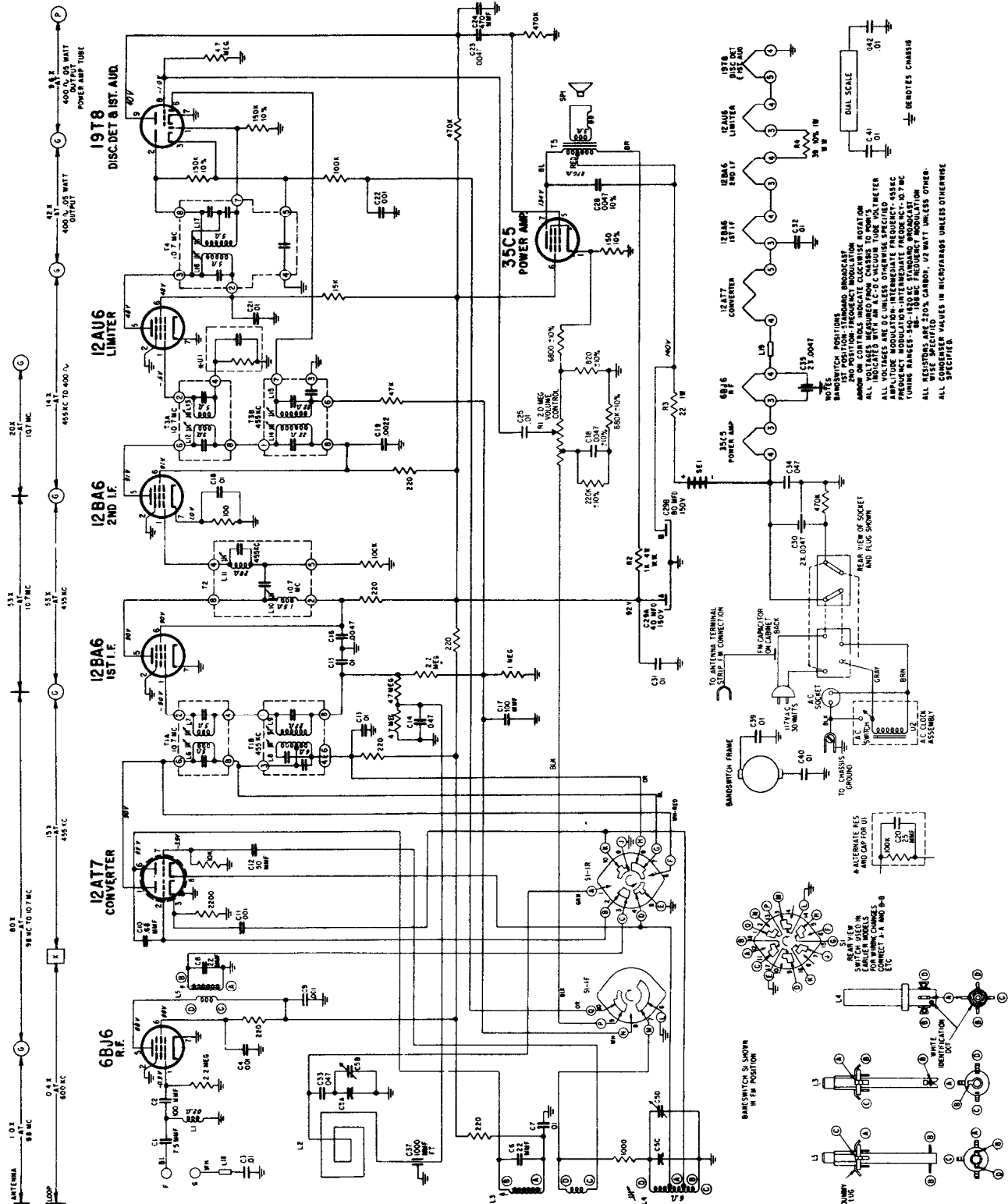

ZENITH RADIO CORP.
 Model B728C, -F, -W, Chassis 7A03
 (Continued from page 182)

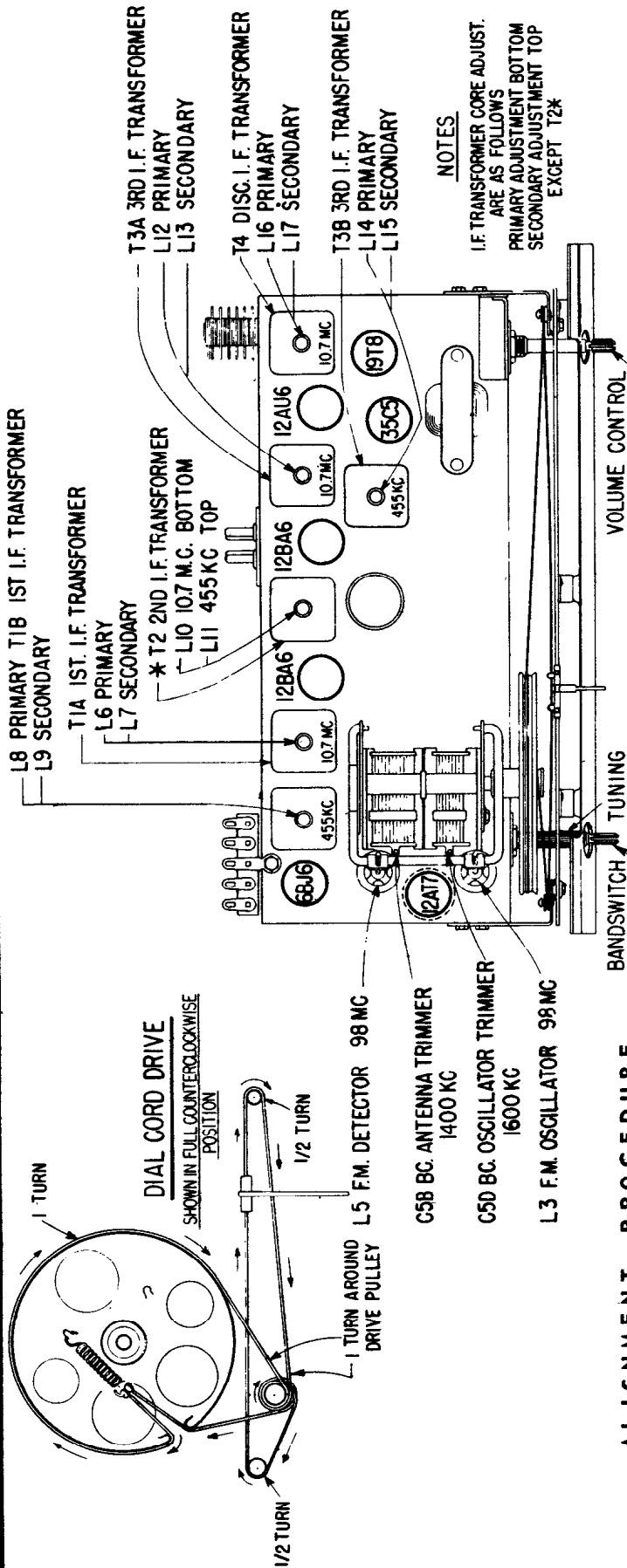

NOTES
 I.F. TRANSFORMER CORE ADJUST.
 ARE AS FOLLOWS
 PRIMARY ADJUSTMENT BOTTOM
 SECONDARY ADJUSTMENT TOP
 EXCEPT T2*

ALIGNMENT PROCEDURE

| OPERATION | CONNECT OSCILLATOR TO | DUMMY ANTENNA | INPUT SIGNAL FREQUENCY | BAND | SET DIAL TO | ADJ. TRIMMERS | PURPOSE |
|------------|---|---------------|------------------------|------|-------------|---|---|
| 1 | Pin 2 12AT7 Converter | .05 Mfd. | 455 Kc. Modulated. | BC | 600 Kc. | L8, 9, 11, 14, 15 | Align I.F. channel for maximum output. |
| 2 | 2 turns loosely coupled to wavemagnet | | 1600 Kc. Modulated. | BC | 1600 Kc. | C5D | Set oscillator to dial scale. |
| 3 | 2 turns loosely coupled to wavemagnet | | 1400 Kc. Modulated. | BC | 1400 Kc. | C5B | Align antenna stage |
| 4 (a) | Pin 1 (grid) on 12AU6 limiter | .05 Mfd. | 10.7 Mc. Unmodulated. | FM | | L16 coil slug Primary discr. | Align primary of discriminator for maximum reading. |
| 5 (b) | Pin 1 (grid) on 12AU6 limiter | .05 Mfd. | 10.7 Mc. Unmodulated. | FM | | L17 coil slug | Adjust secondary of discriminator for zero reading. |
| 6 (c) | Pin 1 (grid) on 12BA6 2nd IF. | .05 Mfd. | 10.7 Mc. Unmodulated. | FM | | L12 & L13 Prim. & Sec. of 3rd IF trans. | Align 3rd IF transformer for maximum reading. |
| 7 (c) | Pin 1 (grid) on 12BA6 1st IF. | .05 Mfd. | 10.7 Mc. Unmodulated. | FM | | L10 Prim. of 2nd IF transformer. | Align 2nd IF transformer for maximum reading. |
| 8 (c) | Pin 2 (grid) on 12AT7 converter tube socket | .05 Mfd. | 10.7 Mc. Unmodulated. | FM | | L6 & L7 Prim. & Sec. of 1st IF trans. | Align 1st IF transformer for maximum reading. |
| 9 (c) | Antenna Post FM (Remove line ant.) | 270 ohms | 98 Mc. Unmodulated. | FM | 98 Mc. | L3 Osc. Coil Slug | Set Oscillator to dial scale. |
| 10 (c) (d) | | 270 ohms | 98 Mc. Unmodulated. | FM | 98 Mc. | L5 Det. Coil Slug | Align det. stage to maximum reading. |

SCHEMATIC DIAGRAM FOR 7AT48Z

VOLUME R-19, MOST-OFTEN-NEEDED 1959 RADIO

ZENITH RADIO Model "ROYAL 200"
Chassis 7AT48Z, 7AT48Z2, 7AT48Z4

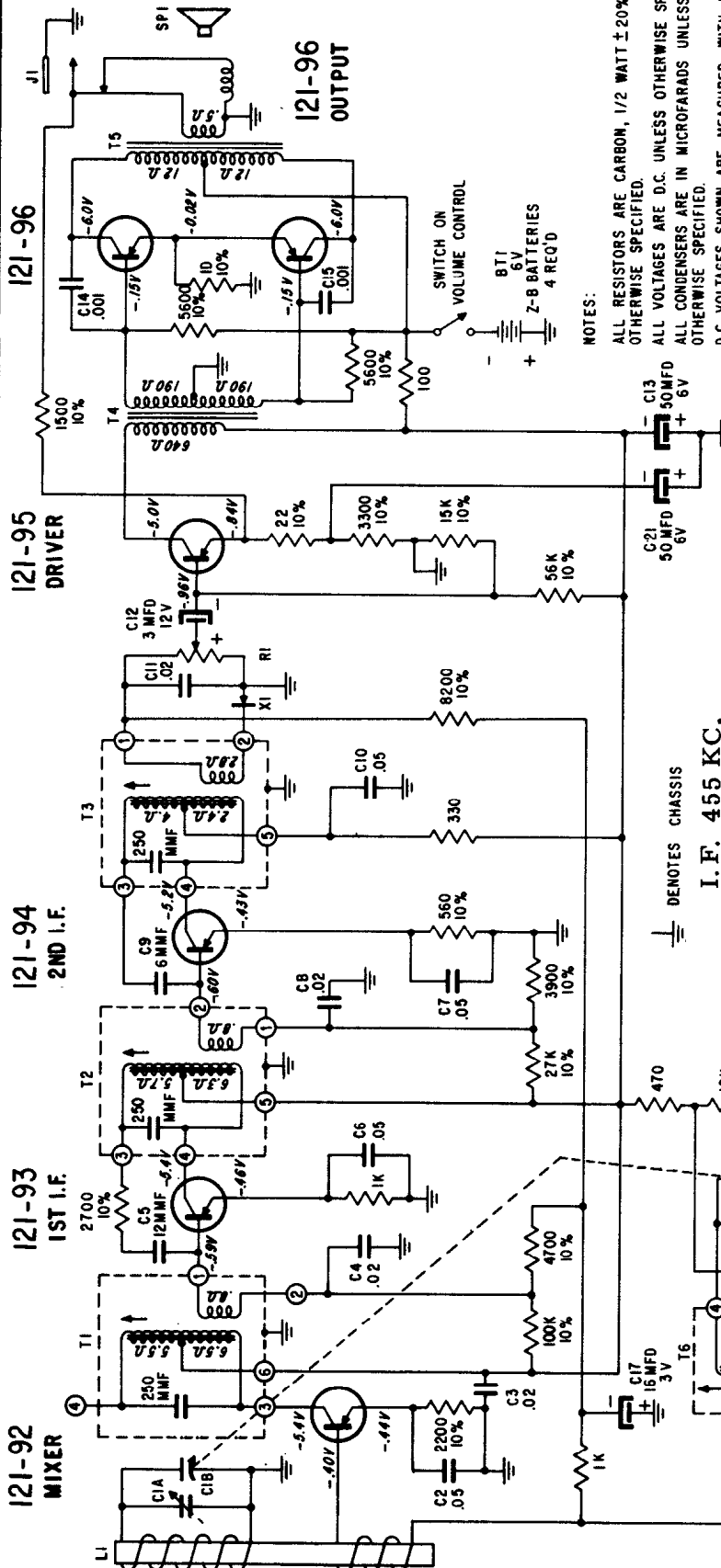

NOTES:
ALL RESISTORS ARE CARBON, 1/2 WATT ±20% UNLESS OTHERWISE SPECIFIED.
ALL VOLTAGES ARE D.C. UNLESS OTHERWISE SPECIFIED.
ALL CONDENSERS ARE IN MICROFARADS UNLESS OTHERWISE SPECIFIED.
D.C. VOLTAGES SHOWN ARE MEASURED WITH NO SIGNAL USING AN A.C.-D.C. OR VACUUM TUBE VOLTMETER.

CHASSIS INFORMATION CHART

| Chassis | Transistor Layout Label Color | Part No. | Mixer | Osc. | 1st I.F. | 2nd I.F. | Crystal Diode Detector | Driver | Output-Output | Supplier |
|---------|-------------------------------------|-------------------------|------------------------|------------------------|-------------------------|-------------------------|------------------------|------------------------|--|----------|
| 7AT48Z | Red 102-4234 or 102-4861 | Zenith RETMA Type | 121-92 2N485 PNP | 121-91 2N483 PNP | 121-93 2N483 PNP | 121-94 2N482 PNP | 103-19 1N87G PNP | 121-95 2N362 PNP | 121-96 2N632 Matched Pair PNP | Raytheon |
| 7AT48Z2 | Black 102-4007 or 102-4862 | Zenith RETMA Type | 121-62 2N411 PNP | 121-65 2N409 PNP | 121-73 2N409 PNP | 121-74 2N409 PNP | 103-19 1N87G PNP | 121-64 PNP | 121-61 Matched Pair PNP | R.C.A. |
| 7AT48Z4 | Green 102-4235 | Zenith RETMA Type | 121-83 2N414 PNP | 121-82 2N413 PNP | 121-79 2N413A PNP | 121-80 2N413A PNP | 103-19 1N87G PNP | 121-81 2N383 PNP | 121-84 2N383 Matched Pair | Tung Sol |

⊥ DENOTES CHASSIS
I. F. 455 KC.

P.N.P. TRANSISTORS

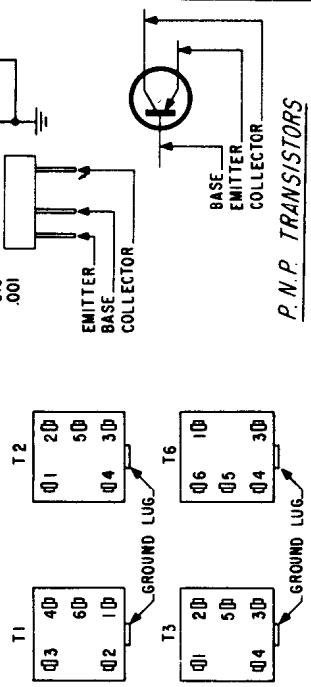

ZENITH RADIO

MODEL "ROYAL 450" -- CHASSIS 7AT45Z1

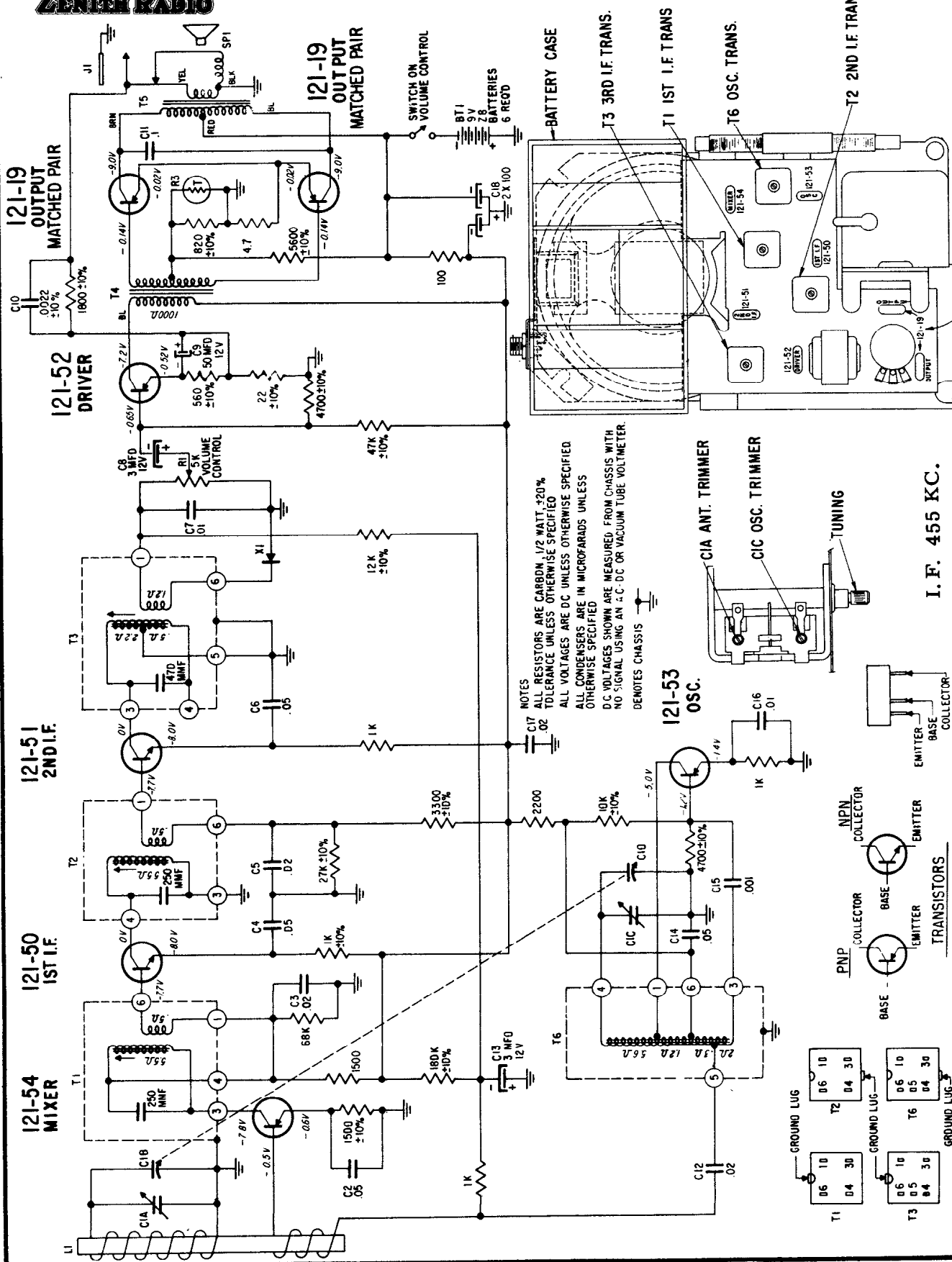

ZENITH RADIO CORPORATION

Model "Royal 750L" -- Chassis 8AT41Z2

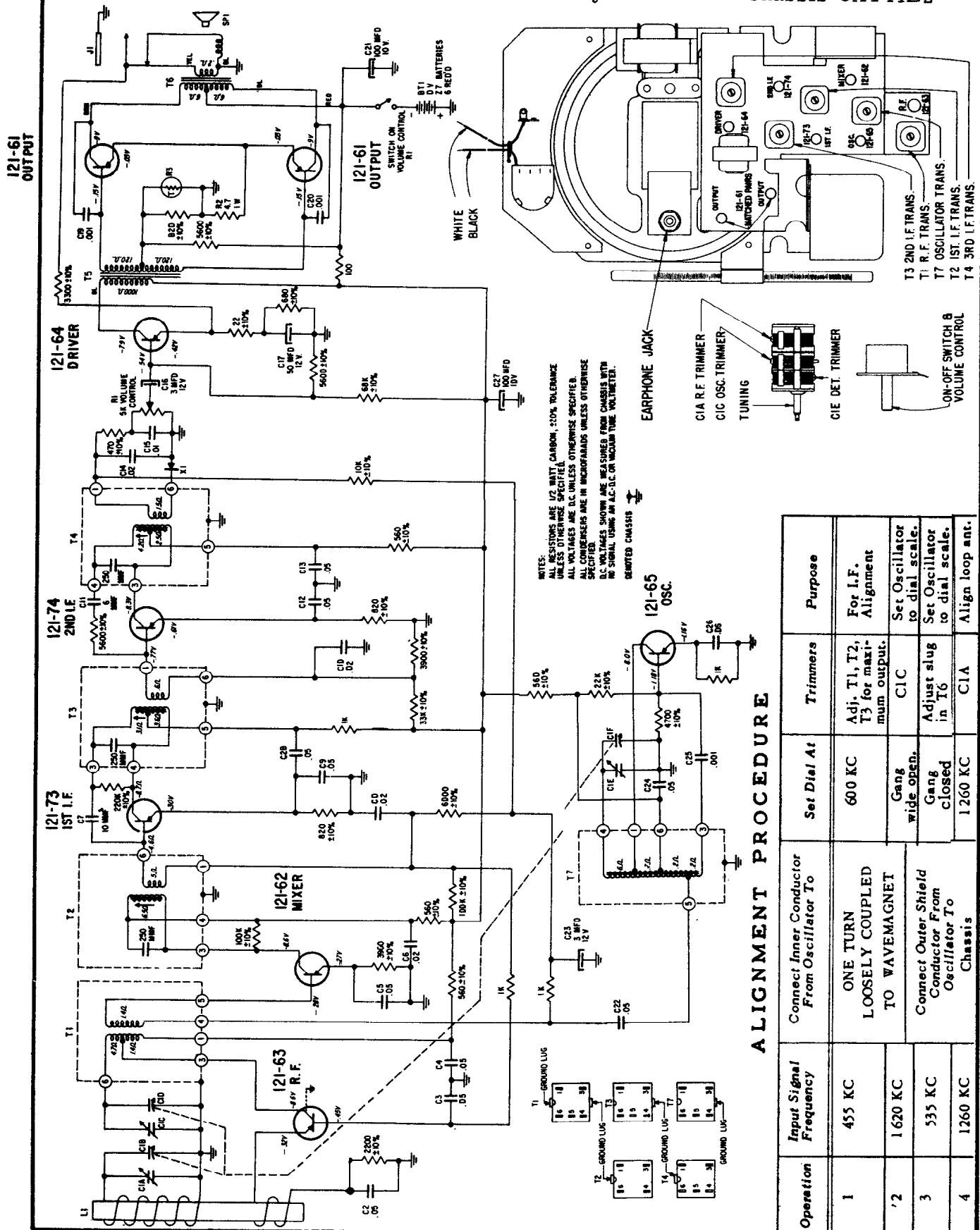

NOTES:
 ALL RESISTORS ARE 1/2 WATT CARBON, ±10% TOLERANCE UNLESS OTHERWISE SPECIFIED.
 ALL VOLTAGES ARE D.C. UNLESS OTHERWISE SPECIFIED.
 ALL CAPACITORS ARE IN MICROFARADS UNLESS OTHERWISE SPECIFIED.
 D.C. VOLTAGES SHOWN ARE MEASURED FROM CHASSIS WITH NO SIGNAL USING AN A.C. D.C. OR VACUUM TUBE VOLTMETER.
 DENOTED CHASSIS

ALIGNMENT PROCEDURE

| Operation | Input Signal Frequency | Connect Inner Conductor From Oscillator To | Set Dial At | Trimmers | Purpose |
|-----------|------------------------|---|-----------------|-------------------------------------|-------------------------------|
| 1 | 455 KC | ONE TURN LOOSELY COUPLED TO WAVEMAGNET | 600 KC | Adj. T1, T2, T3 for maximum output. | For I.F. Alignment |
| 2 | 1620 KC | Connect Outer Shield Conductor From Oscillator To Chassis | Gang wide open. | C1C | Set Oscillator to dial scale. |
| 3 | 535 KC | | Gang closed | Adjust slug in T6 | Set Oscillator to dial scale. |
| 4 | 1260 KC | | 1260 KC | C1A | Align loop ant. |

12I-96
OUTPUT

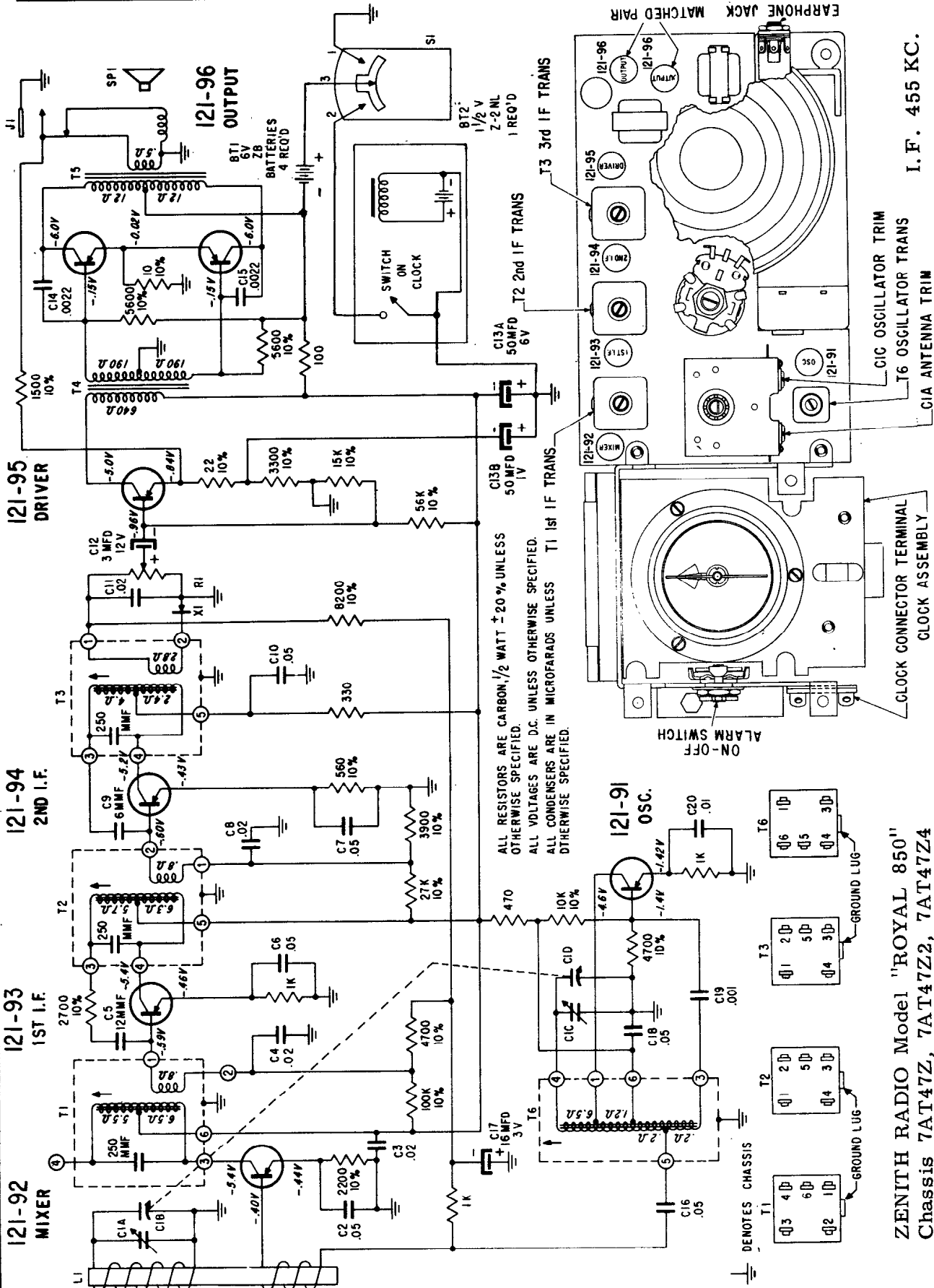

ALL RESISTORS ARE CARBON, 1/2 WATT ±20% UNLESS OTHERWISE SPECIFIED.
ALL VOLTAGES ARE D.C. UNLESS OTHERWISE SPECIFIED.
ALL CONDENSERS ARE IN MICROFARADS UNLESS OTHERWISE SPECIFIED.

I. F. 455 KC.

ZENITH RADIO Model 'ROYAL 850'
Chassis 7AT47Z, 7AT47Z2, 7AT47Z4

ZENITH RADIO CORP.

MODEL "ROYAL 760" RADIO CHASSIS 8AT42Z2

(Alignment information on page 189)

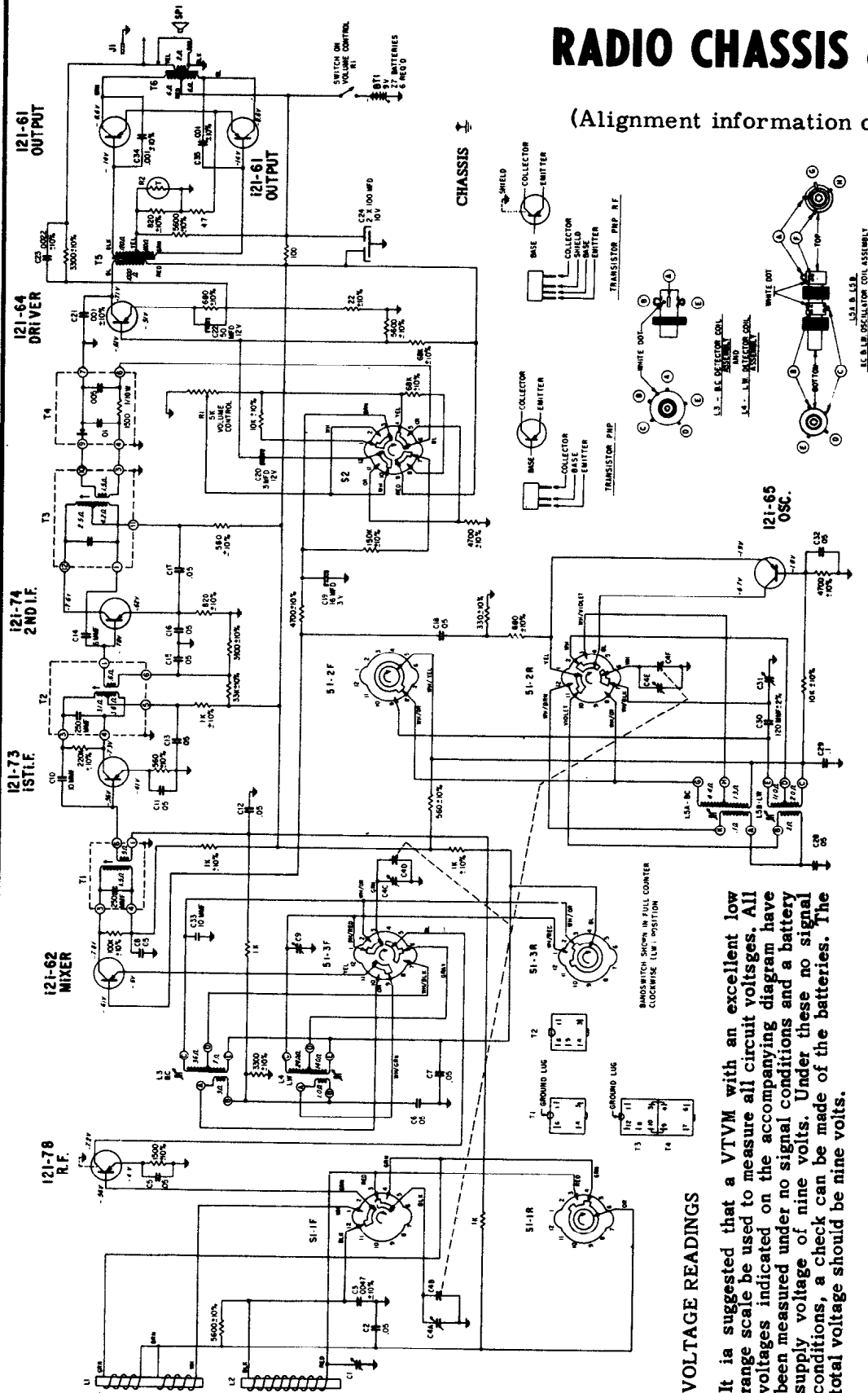

NOTES:
 ALL RESISTORS ARE 1/2 WATT. CARBON ±20% TOLERANCE UNLESS OTHERWISE SPECIFIED.
 ALL VOLTAGES ARE D.C. UNLESS OTHERWISE SPECIFIED.
 ALL CONDENSERS ARE IN MICROFARADS UNLESS OTHERWISE SPECIFIED.
 D.C. VOLTAGES SHOWN ARE MEASURED FROM CHASSIS WITH BANDSWITCH IN BROADCAST POSITION AND NAVIGATE NORMAL SWITCH IN NORMAL POSITION WITH NO SIGNAL USING AN A.C. D.C. OR VACUUM TUBE VOLTMETER.

VOLTAGE READINGS

It is suggested that a VTVM with an excellent low range scale be used to measure all circuit voltages. All voltages indicated on the accompanying diagram have been measured under no signal conditions and a battery supply voltage of nine volts. Under these no signal conditions, a check can be made of the batteries. The total voltage should be nine volts.

COMPONENT REPLACEMENT

When soldering components at the base of the transistor socket, it is suggested that the transistor be removed to avoid any possibility of excessive heat being transferred through the socket to the transistor. When soldering the low voltage electrolytica and germanium diodes, it is suggested that the wire be held with a pair of long nose pliers while soldering. The long nose pliers will act as a heat sink.

ZENITH RADIO CHASSIS 8AT42Z2
 MODEL "ROYAL 760"
 (Continued from page 188)

ALIGNMENT PROCEDURE

NOTE: Alignment must be made with Nor. - Nav. switch in Nor. position.

| OPER. | CONNECT GEN. TD DUMMY ANTENNA | INPUT SIG. FREQUENCY | BAND | SET DIAL AT | TRIMMERS | PURPOSE |
|---------------------------|---|--------------------------|------|-------------|-----------------------|------------------------------------|
| 1 | One turn loop coupled loosely to Broadcast Wavemagnet | 455 Kc | BC | 1600 Kc | T1, T2, T3 | Align I.F. |
| * 2 | One turn loop coupled loosely to Broadcast Wavemagnet | 600 Kc | BC | 600 Kc | Rock Gang, Adjust L5A | Alignment of BC at 600 Kc |
| 3 | One | 1600 Kc | BC | 1600 Kc | C4E | Set osc. to scale |
| REPEAT OPERATIONS 2 & 3 | | | | | | |
| 4 | Turn Loop Coupled | 600 Kc | BC | 600 Kc | Rock, Adjust L3 | Alignment of BC detector at 600 Kc |
| * 5 | Loosely to Broadcast Wavemagnet | 1400 Kc | BC | 1400 Kc | C4C | Alignment BC detector |
| REPEAT OPERATIONS 5 & 6 | | | | | | |
| 7 | Broadcast Wavemagnet | 1400 Kc | BC | 1400 Kc | C4A | Alignment of BC antenna |
| 8 | | 165 Kc | LW | 165 Kc | Rock Gang, Adjust L5B | Alignment of LW at 165 Kc |
| * 9 | One turn coupled loosely to Long Wave Wavemagnet | 400 Kc | LW | 400 Kc | C31 | Set osc. to scale |
| * 10 | One | REPEAT OPERATIONS 9 & 10 | | | | |
| 11 | Turn Loop Coupled | 165 Kc | LW | 165 Kc | Rock, Adjust L4 | Alignment LW detector at 165 Kc |
| * 12 | Loosely to Long Wave Wavemagnet | 370 Kc | LW | 370 Kc | C9 | Alignment LW detector |
| REPEAT OPERATIONS 12 & 13 | | | | | | |
| 14 | Long Wave Wavemagnet | 370 Kc | LW | 370 Kc | C1 | Alignment of LW antenna |
| 15 | | | | | | |

*NOTE: Rock tuning condenser when making alignment under Operations 2, 5, 9, 10, 12, 13.

| Chassis | Chassis Color Dot | Transistor Layout Label Color | Part No. | R.F. | Mixer | Osc. | 1st I.F. | 2nd I.F. | Crystal Diode Detector | Driver | Output-Output | Supplier |
|---------|-------------------|-------------------------------|----------------------|------------|------------|------------|------------|------------|------------------------|------------|-------------------------|----------|
| 8AT42Z2 | Black | Black | Zenith Type 102-3497 | 121-78 PNP | 121-62 PNP | 121-65 PNP | 121-73 PNP | 121-74 PNP | 103-22 IN25 | 121-64 PNP | 121-61 Matched Pair PNP | R.C.A. |

TRANSISTOR & TRIMMER LAYOUT FOR 8AT42Z2

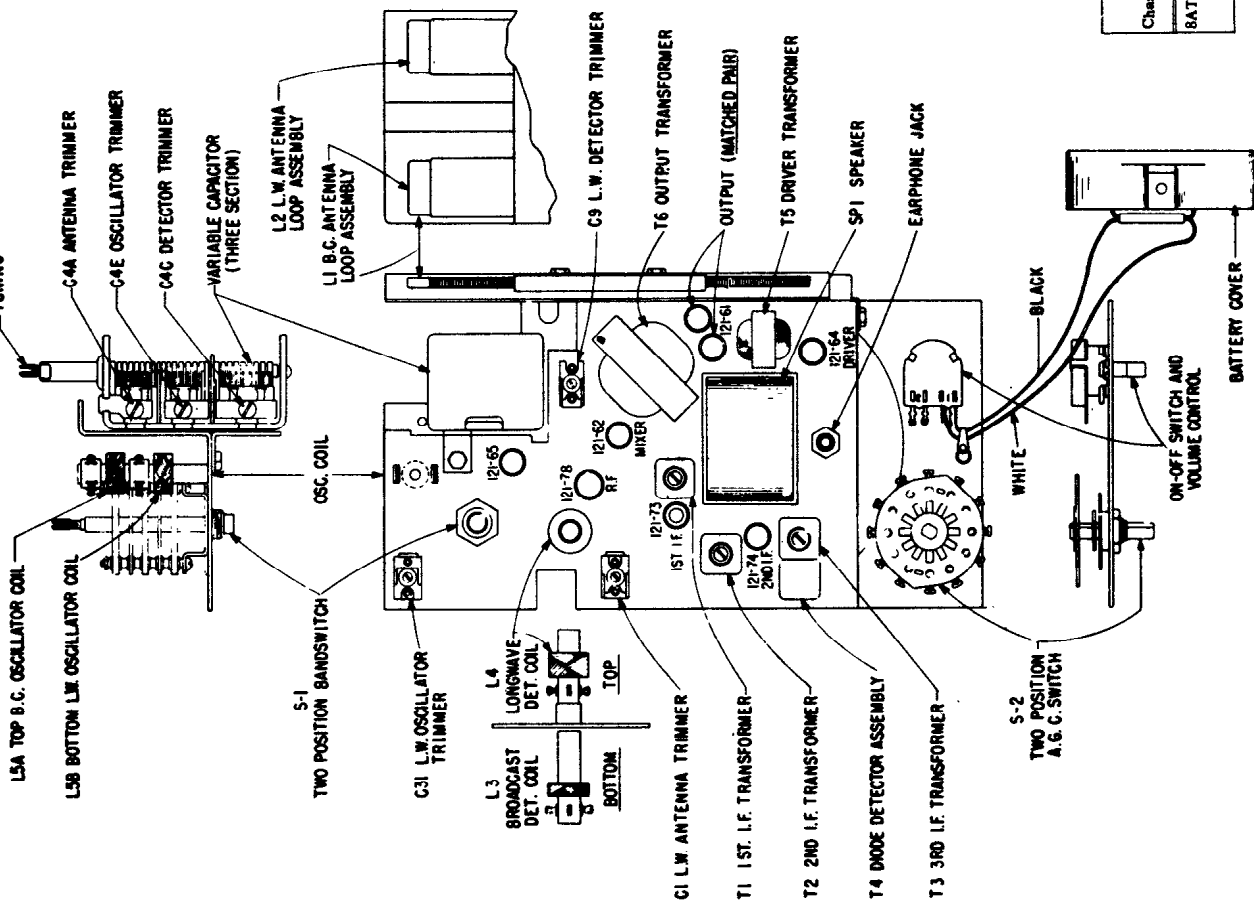

ZENITH RADIO CORP.

CHASSIS 7AT44Z1

MODEL "ROYAL 900"

I. F. 455 KC.

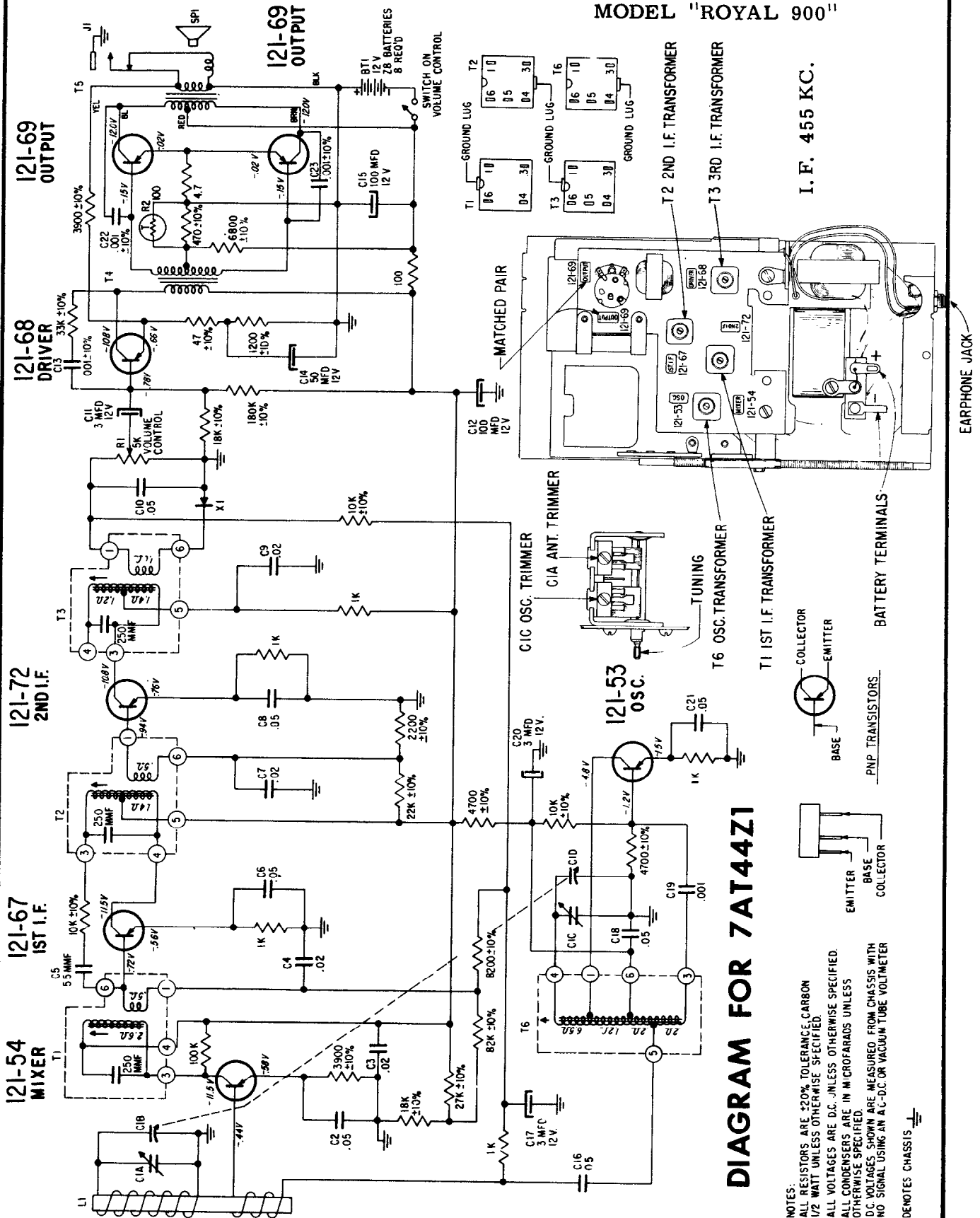

DIAGRAM FOR 7AT44Z1

NOTES:
 ALL RESISTORS ARE ±20% TOLERANCE, CARBON
 1/2 WATT UNLESS OTHERWISE SPECIFIED.
 ALL VOLTAGES ARE D.C. UNLESS OTHERWISE SPECIFIED.
 ALL CONDENSERS ARE IN MICROFARADS UNLESS
 OTHERWISE SPECIFIED.
 D.C. VOLTAGES SHOWN ARE MEASURED FROM CHASSIS WITH
 NO SIGNAL USING AN A-C-D.C. OR VACUUM TUBE VOLTMETER
 DENOTES CHASSIS

Index

| | | | | |
|----------------------|----------------------|-----------------------|----------------------|------------------------|
| Admiral Corp. | Arvin, Cont. | Emerson, Cont. | G E Continued | Motorola, Cont. |
| 4S2 6 | 8584 16 | 971, A 37 | P715, B, D 50 | 6X28P, W 80 |
| 5T4A 9 | 1.43700 17 | also 38 | P716, B, D 50 | 7X23E 94 |
| 5W4 3 | 1.43800 13 | 999 36 | P725B 51 | 7X24S, W 94 |
| 6T2 4 | 1.43900 17 | 999R 36 | P726B 51 | 7X25P, W 91 |
| 7N1 6 | 1.44100 15 | 120392B 32 | P735A 52 | 8X26E, S 92 |
| 7N1A 6 | 1.44200 15 | 120394B 33 | P736A 52 | 9AX 65 |
| 8M1 5 | 1.44600 16 | 120399B 33 | P755A 53 | BKA9X 66 |
| 8S1 8 | 1.45000 12 | 120416 34 | P805 53 | CTA9X 66 |
| 8S1A 8 | 1.45200 14 | 120430B 33 | P806 53 | CTM9X 67 |
| 12B1, -A 9 | | 120431B 35 | RP1110A 55 | OEA9X 66 |
| 392 6 | Buick | 120432B 33 | RP1120A, B 56 | PCA9X 66 |
| 393 6 | 981968 18-19 | 120433B, R 36 | RP1160A 57 | SF11B, N 95 |
| 462 6-7 | 981969 30-31 | 120455B 37 | RT1230A 58 | SH12E, N, S 96 |
| 463 6-7 | 981970 20-21 | 120456B 38 | RT1231A 58 | S21B, + 97 |
| 521 4 | | 120459B 37 | | SK21B, + 97 |
| 528 4 | Chevrolet | 120462B 38 | Granco | SK23B, + 97 |
| 561 8 | 987888 22-23 | Ford | 601 60 | 93MR 68 |
| 566 8 | 987891 24-25 | B9FA-18805E | 701 61 | 94MA 69 |
| 581 3 | 987893 30-31 | B9FA-18806B | | 94MF 70 |
| 582 3 | | B9FA-18806C | Montgomery | 94MFM 70 |
| 632 9 | Delco | pages 70 & 71 | Ward | 95MF 71 |
| 633 9 | 981968 18-19 | General-Elect. | H-667P5 160 | 300X 72 |
| 634 9 | 981969 30-31 | AS2 56 | GEN-1115A 62 | 301X 73 |
| 642 9 | 981970 20-21 | AS15A 59 | GEN-1116A 62 | 406 74 |
| 643 9 | 987888 22-23 | AS16A 59 | GTM-1117A 160 | HS-633 78 |
| 644 9 | 987891 24-25 | T105A 39 | 1120A, B 63 | HS-637 79 |
| 649 9 | 987893 30-31 | T106A, B 39 | GEN-1628A 64 | HS-638 80 |
| 654 9 | 988976 26-27 | T107B 39 | | HS-647 81 |
| 662 9 | 988977 30-31 | T115A 40 | Motorola | HS-652 82 |
| 663 9 | 988978 20-21 | T116A 40 | 2F11B, R 87 | HS-653 83 |
| 664 9 | 989170 28-29 | T120A, B 41 | 2F12N, W 87 | HS-654 83 |
| 671 9 | 989171 30-31 | T125A 42 | 3F13B, W 87 | HS-658 84 |
| 801 5 | 989172 20-21 | T126A 42 | 5C11E 84 | HS-660 85 |
| 802 5 | | T127A 42 | 5C12M, P, W 84 | HS-661 85 |
| 808 5 | | T130A, B 43 | 5C13+ 85 | HS-662 86 |
| 811 8 | Emerson Radio | T131A, B 43 | 5C14+ 85 | HS-663 85 |
| 816 8 | 834X 33 | T132A, B 43 | 5C16NW, W 85 | HS-666 87 |
| | 877 32 | T135A 44 | 5C15+ 86 | HS-667 87 |
| American | 888 34 | T210A 45 | 5K11+ 89 | HS-668 87 |
| Motors | 890 33 | C400A 46 | 5P21B, N, R 78 | HS-670 88 |
| 8990576 69 | 891B 33 | C401A 46 | 5P22+ 81 | HS-673 89 |
| 8990582 68 | 892A 33 | C405A, B 47 | 5P23+ 81 | HS-675 90 |
| | 893B 33 | C406A, B 47 | 5R14N 88 | HS-678 91 |
| Arvin | 894B 33 | C435A 48 | 5T11G, M 82 | HS-679 92 |
| 2581 13 | 895B 35 | C440A 49 | 5T11R, W 82 | HS-680 93 |
| 2584 15 | 896B 37 | C441A 49 | 5T12+ 83 | HS-688 94 |
| 2585 12 | 898B 38 | P671A, B 54 | 5T13+ 83 | GV-701 75 |
| 3588 14 | 902 37 | P672A, B 54 | 6K13+ 90 | HS-703 95 |
| 5583 15 | 903 38 | P673A, B 54 | 6P25E, N, S 79 | HS-704 96 |
| 8581 17 | 970 37 | P674B 54 | 6T15N, S 93 | HS-735 97 |
| 8583 17 | also 38 | | 6X28B, N 80 | GV-800 76 |

VOLUME R-19, MOST-OFTEN-NEEDED 1959 RADIO SERVICING INFORMATION

| | | | | |
|------------------------|-----------------------|------------------------|----------------------|----------------------|
| Motorola, Cont. | Pontiac | Sylvania, Cont. | Westinghouse+ | Westinghouse+ |
| 8990576 69 | 988976 26-27 | 1107 137 | H-46AC3 166 | V-2506-2 167 |
| 8990582 68 | 988977 30-31 | 1108 138 | H-48SE1 168 | V-2506-3 167 |
| | 988978 20-21 | 1303 139 | H-48SE2 168 | |
| Oldsmobile | | 1304 140 | H-48SE3 168 | Zenith Radio |
| 989170 28-29 | RCA Victor | 2108 137 | H-48SE4 168 | SRS2 172 |
| 989171 30-31 | LBT2 131 | 2109 138 | H-48SE5 168 | 3B30 170-171 |
| 989172 20-21 | LBT3 132 | 2305 140 | HR102S 164 | 3Z04 169 |
| Olympic Radio | AK-1 127 | 4312 136 | HR103S 164 | 4B22 170 |
| 688 98 | C-1 133 | 4413 142 | HF-110AN 165 | 4B23 170 |
| | X-1 133 | 4416 141 | HF-111AN 165 | 4B24 172 |
| Packard-Bell | SA-2 124 | 4419 141 | H-629T4A 151 | 4B25 172 |
| 5R5 99 | X-2 133 | 4422 142 | H-630T4A 151 | 5B01 173 |
| 6RT2 100 | BC-3 131 | | H-631T4A 151 | 5B04 174 |
| | SA-3 124 | Trav-ler | H-632T5A 154 | 5B06 174 |
| | BCS-4 131 | 48-314 143 | H-633T5A 154 | 5B10 175 |
| Philco Corp. | SES-6 128 | 90-105 144 | H-636T6A 155 | 5B11 175 |
| T-3 (early) 101 | 9TX2 130 | TR-280A 143 | H-637T6A 155 | 5B20 176 |
| T-3 (late) 102 | SHP-11 126 | TR-281A 143 | H-649T7A 156 | 5B22 177 |
| T-4 103 | SHP-11 126 | TR-282A 143 | H-650T7A 156 | 5B24 178 |
| T-4J 103 | SHP-12 127 | TR-283A 143 | H-655P5 157 | 6B05 179 |
| T-5 104 | SHP-13 127 | | H-656P5 157 | 6B06 180 |
| T-6 110 | SHP-14 129 | Truetone, see | H-657P5 157 | BP6B, L, V 181 |
| T-7X 105 | HF-99 125 | Western Auto | H-659P4 158 | 7A03 182 |
| T-60 106 | RS-151B 124 | | H-660P4 158 | 7AT44Z1 190 |
| T-65 107 | RS-157D 125 | United Motors | H-662P4 159 | 7AT45Z1 185 |
| T-75 108 | RS-171A 126 | see Delco | H-663P4 159 | 7AT47Z 187 |
| RT-150 122 | RS-172 127 | | H-664P4 159 | 7AT47Z2 187 |
| RT-202 109 | RS-175 128 | Wards, see | H-666P5 160 | 7AT47Z4 187 |
| T-600 110 | RS-175A 129 | Montgomery | H-667P5 160 | 7AT48Z 184 |
| G-681 111 | RC-1156C 130 | | H-677T4 152 | 7AT48Z2 184 |
| H-691 112 | RC-1187 131 | Webcor | H-678T4 152 | 7AT48Z4 184 |
| G-749 113 | RC-1187A 132 | 14X278-1 145 | H-679T4 152 | BP7F 181 |
| G-751 113 | RC-1188 133 | 14X278-2 145 | H-681T5 161 | 8AT41Z2 186 |
| G-753 113 | RC-1188A 133 | 14X280-1 146 | H-682T5 161 | 8AT42Z2 188 |
| G-755 113 | | 14X280-2 148 | H-683T5 161 | SRS10 178 |
| G-820 114 | Roland | 14X307 147 | H-685P8 162 | SRS15 178 |
| G-822 114 | 71-483 134 | 73X014-1 145 | H-686P8 162 | HF110G, J 169 |
| G-824 114 | | 1953 145 | H-690P5 163 | SF112 172 |
| G-826 114 | Spartan | 1954-1 146 | H-693P8 153 | HF116E, R 176 |
| G-828 114 | 51-01 135 | 1956 147 | H-694P8 153 | HF117 177 |
| G-974 115 | 51-04 135 | 1963 148 | H-695P8 153 | HF118 177 |
| G-978 116 | 51-07 135 | 1991 145 | V-2239-6 152 | SF174R 170 |
| SA-1000 120 | 51-09 135 | | V-2239-7 151 | SF177E, R 170 |
| G-1407 119 | 51-11 135 | Western Auto | V-2278-5 153 | 200 184 |
| G-1409 118 | | D2832A 149 | V-2390-4 154 | 450 185 |
| G-1410 117 | Sylvania Elec. | D2832B 149 | V-2391-6 155 | B509C, + 175 |
| SA-1500 122 | 1-609-7 136 | D2834A 149 | V-2392-4 156 | B511B, + 175 |
| G-1606, S 120 | 1-629-1, 2 137 | D2834B 149 | V-2393-1 157 | B513F, L 173 |
| G-1706, S 122 | 1-630-1, 2 138 | DC2988A 150 | V-2394-1 158 | B513V, Y 173 |
| G-1707, S 122 | 1-631-1 139 | DC2989A 150 | V-2394-2 159 | B514F, + 174 |
| G-1708S 121 | 1-632-1, 2 140 | | V-2394-3 160 | B515B, + 174 |
| G-1806S 121 | 1-639-1 136 | Westinghouse | V-2395-1 161 | B615, F, + 179 |
| G-1807S 121 | 1-640-1 141 | H-44AC1A 167 | V-2396-1 162 | HF660 180 |
| G-1808S 121 | 1-642-1 141 | H-44AC2A 167 | V-2397-1 163 | B728C, + 182 |
| G-1809S 121 | 1-645-1 142 | H-45AC1A 167 | V-2502-5 164 | 750L 186 |
| G-1811S 121 | SC03 136 | H-45AC2A 167 | V-2503-2 165 | 760 188-189 |
| G-1813S 121 | | H-46AC1 166 | V-2503-3 166 | 850 187 |
| SA-2000 121 | | H-46AC2 166 | V-2503-5 168 | 900 190 |