

Most - Often - Needed

1961

Volume R-21

RADIO
DIAGRAMS
and Servicing Information



Compiled by
M. N. BEITMAN

SUPREME PUBLICATIONS



SUPREME 1961 TV Manual

COVERS ALL POPULAR SETS

Here is your service data for faster, easier TV repairs. Lowest priced. Best by comparison. *Supreme TV manuals* have all needed service material on every popular TV set. Helpful, practical, factory-prepared data that will really make TV servicing easy for you. Benefit and save with these amazing values in service manuals. Only \$3 per large, yearly volume.



The repair of any television set is really simple with *Supreme TV service manuals*. Every set is covered in a practical manner that will simplify trouble-shooting and repair. This is the help you need to find toughest faults in a hurry. Most \$3 TV volumes cover a whole year of service material. New *Television Servicing Course* will aid you in learning TV. Be wise. Buy *Supreme Manuals* only once each year instead of spending dollars every week.

AMAZING BARGAIN

The new 1961 TV manual is the bargain of the year. Covers all important sets of every make in one giant volume. Your price for this mammoth manual is only \$3. This super-value defies all competition. Other annual volumes at only \$3 each. Factory service material simplifies repairs. Includes all data required for quicker TV servicing. Practically tells you how to find each fault and make needed repair. More pages, more diagrams, more service data per dollar of cost.

SIMPLIFIES TV REPAIRS

These giant TV manuals have complete circuits, needed alignment facts, printed boards, servicing hints, production changes, voltage charts, waveforms, and double-page schematics. Here are your authentic service instructions to help you do expert work quicker: and priced at only \$3 per large annual manual. Repair any TV model ever made by having in your shop all 15 volumes as listed in coupon. Your special price for all, only \$40. Or try the new 1961 TV manual to see what an amazing bargain you get for \$3. Send no-risk trial coupon today.



TELEVISION SERVICING COURSE

Let this new course help you in TV servicing. Amazing bargain complete. Only \$3 full price for all lessons. Giant in size, mammoth in scope, topics just like a \$200.00 correspondence course. Lessons on picture faults, circuits, adjustments, short-cuts, UHF, alignment facts, hints, antenna problems, trouble-shooting, test equipment, picture analysis. Special, only **\$3**

SIMPLIFIED RADIO SERVICING BY COMPARISON

Fix any radio easily. New, different COMPARISON method finds faults quickly. Covers every radio set—new and old models. Introductory training included. Simple picture suggestions tell you where to look for faults. No testers needed for most jobs. Explains parts, transistors, etc. Manual form, large pages, 8 1/2 x 11". Special price, only **\$1.50**

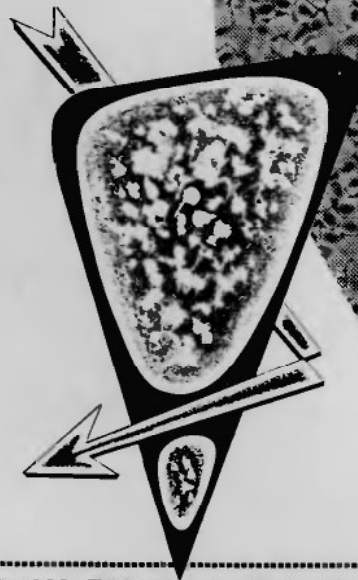

RADIO VOLUMES



RADIO DIAGRAMS

SUPREME is your best source for all needed **RADIO** diagrams and service data. Covers everything from the most recent 1960 radios to pre-war old-timers; home radios, stereo, combinations, transistor portables, FM, and auto sets. Sensational values. Only \$2 for many volumes. Every manual has extra large schematics, all needed alignment facts, printed boards, voltage values, trimmers, dial stringing, and helpful hints. Volumes are large in size, 8 1/2 x 11 inches, about 190 pages. See coupon at right for a complete list of these popular radio service manuals. →

NO-RISK TRIAL ORDER COUPON

SUPREME PUBLICATIONS, 1760 Balsam Rd., Highland Park, ILL.

<input type="checkbox"/> 1960 <input type="checkbox"/> 1959 <input type="checkbox"/> 1958 <input type="checkbox"/> 1957 <input type="checkbox"/> 1956 <input type="checkbox"/> 1955 <input type="checkbox"/> 1954 <input type="checkbox"/> 1953 <input type="checkbox"/> 1952 <input type="checkbox"/> 1951 <input type="checkbox"/> 1950 <input type="checkbox"/> 1949 <input type="checkbox"/> 1948 <input type="checkbox"/> 1947 <input type="checkbox"/> 1946 <input type="checkbox"/> 1945 <input type="checkbox"/> 1944 <input type="checkbox"/> 1943 <input type="checkbox"/> 1942 <input type="checkbox"/> 1941 <input type="checkbox"/> 1940 <input type="checkbox"/> 1938-1939 <input type="checkbox"/> Simplified Servicing, \$1.50	Popular RADIO Diagram Manuals at only \$2.50 each Radio Manual, only \$2 These annual RADIO volumes specially priced at only \$2.50 each THIS GROUP ONLY \$2 EACH 1926-1938 Manual, \$2.50 Simplified Servicing, \$1.50	Rush today TV manuals checked <input checked="" type="checkbox"/> below and Radio manuals at left. Satisfaction guaranteed. <input type="checkbox"/> New 1961 TV Manual, \$3. <input type="checkbox"/> 1960 TV, \$3. <input type="checkbox"/> Additional 1959 TV, \$3. <input type="checkbox"/> Early 1959 TV, \$3. <input type="checkbox"/> 1958 TV Manual, \$3. <input type="checkbox"/> Additional 1957 TV, \$3. <input type="checkbox"/> Early 1957 TV, \$3. <input type="checkbox"/> 1956 TV Manual, \$3. <input type="checkbox"/> Additional 1955 TV, \$3. <input type="checkbox"/> Early 1955 TV, \$3. <input type="checkbox"/> 1954 TV, \$3. <input type="checkbox"/> 1953 TV, \$3. <input type="checkbox"/> 1952 TV, \$3. <input type="checkbox"/> 1951 TV, \$3. <input type="checkbox"/> 1957-58 RCA TV Manual, \$1.50 <input type="checkbox"/> New Television Servicing Course, complete... \$3. <input type="checkbox"/> I am enclosing \$..... Send postpaid. <input type="checkbox"/> Send C.O.D. I am enclosing \$.... deposit.
Name:		Address:

Supreme Publications
Sold by All Leading Parts Jobbers

ADMIRAL CHASSIS 3N1A, MODELS Y4049, Y4071, Y4072, Y4073

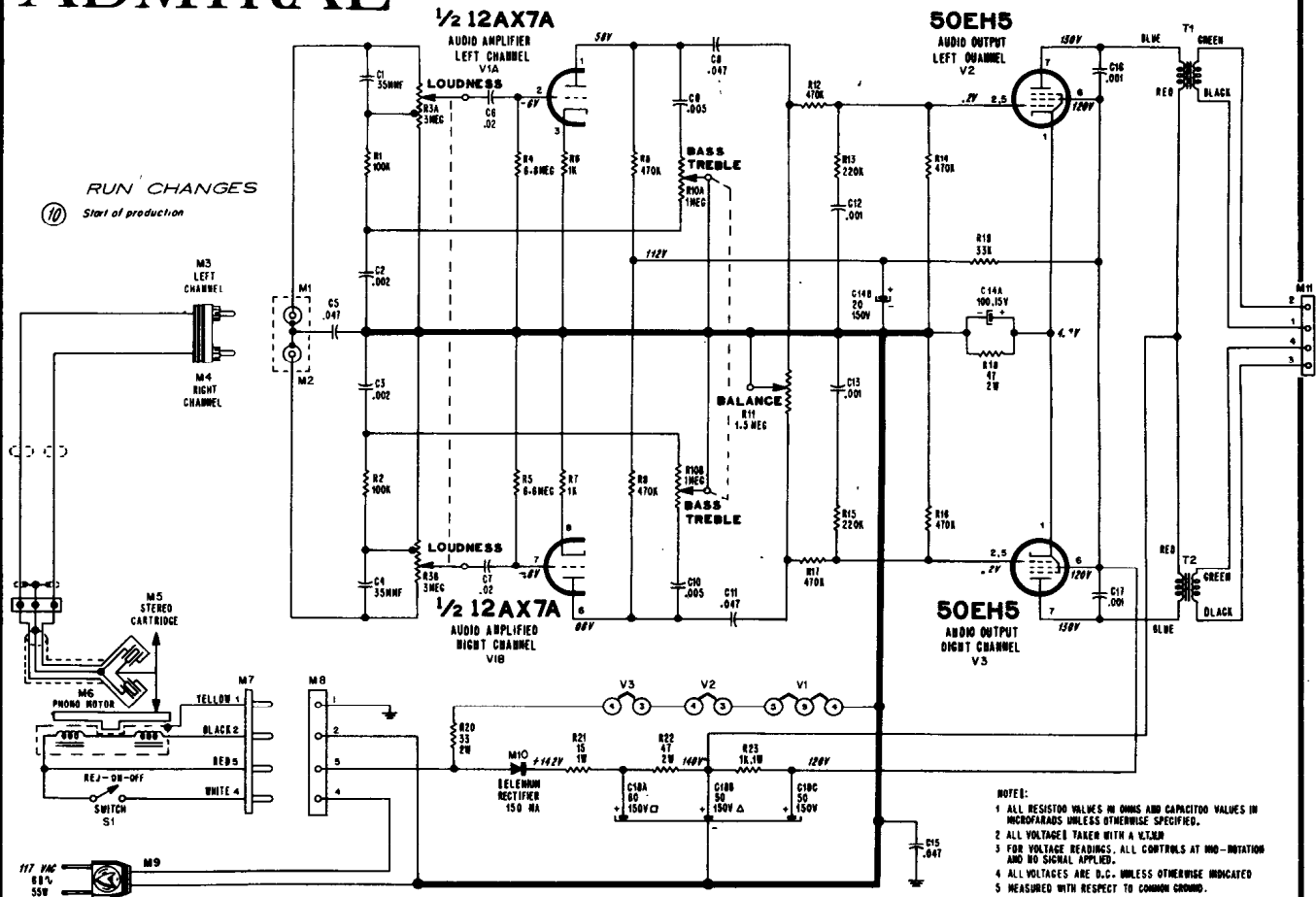

RUN CHANGES
 (10) Start of production

Schematic of 3N1A Stereophonic High Fidelity Amplifier Stamped Run 10.

- NOTE:**
- 1 ALL RESISTOR VALUES IN OHMS AND CAPACITOR VALUES IN MICROFARADS UNLESS OTHERWISE SPECIFIED.
 - 2 ALL VOLTAGE TAPERS WITH A V.T.A.M.
 - 3 FOR VOLTAGE READINGS, ALL CONTROLS AT 100-ROTATION AND NO SIGNAL APPLIED.
 - 4 ALL VOLTAGES ARE D.C. UNLESS OTHERWISE INDICATED
 - 5 MEASURED WITH V3 REMOVED TO COMMON GROUND.
 - 6 MEASURED WITH V1 REMOVED FROM SOCKET.
 - 7 MEASURED WITH V1 AND V2 REMOVED FROM SOCKET.
- ⊕ CHASSIS GROUND ⊖ COMMON GROUND

RUN 11 In All Sets
 To improve performance (tonal quality) at low volume level, resistors R1 and R2 were changed from 100,000 ohms to one megohm, one-half-watt.

CHASSIS REMOVAL

Model Y4049: Remove the metal grille by removing the screws along the top and side of the grille.

Disconnect the phono motor plug (M7), the two channel input plugs (M3 and M4), and speaker plug (M12). Remove the three control knobs by pulling them straight out from the control shafts.

Remove the screws holding the phono motor board. Lift the board with the record changer out of cabinet. To avoid marring the cabinet or damaging the record changer, do not allow the bottom of the record changer to scrape across the cabinet when removing.

Remove the four nuts holding the chassis to the cabinet. Remove chassis from cabinet.

Models Y4071, Y4072 and Y4073: Disconnect the phono motor plug (M7), the two channel input plugs (M3 and M4), and speaker plug (M12). Remove the three control knobs by pulling them straight out from the control shafts.

Remove the four nuts holding the chassis to the cabinet. Remove chassis from cabinet.

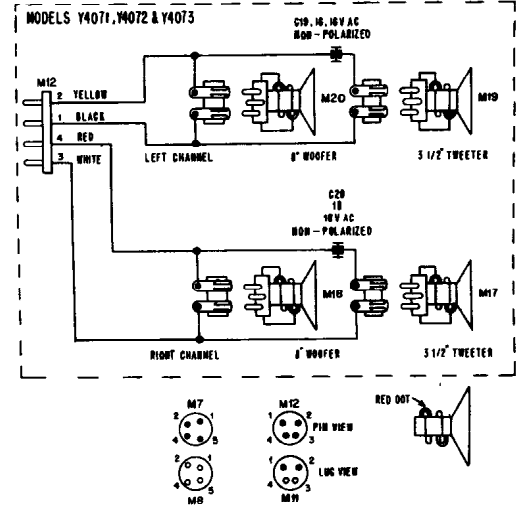
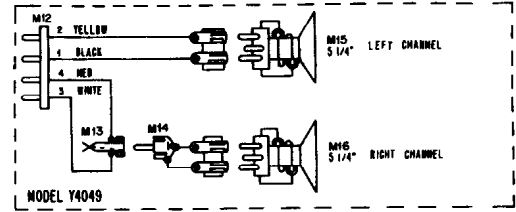

ADMIRAL

TABLE CLOCK RADIO

MODEL	COLOR	CHASSIS
Y1189A	Grey-Green	4E3A

CLOCK RADIO

MODEL	COLOR	NAME	CHASSIS
Y3037	Beige and White	Sinclair	4N3
Y3038	Turquoise and White		

The tube complement, tube locations and etched wiring board of the 4N3 chassis, is identical to that of the 4E3A chassis.

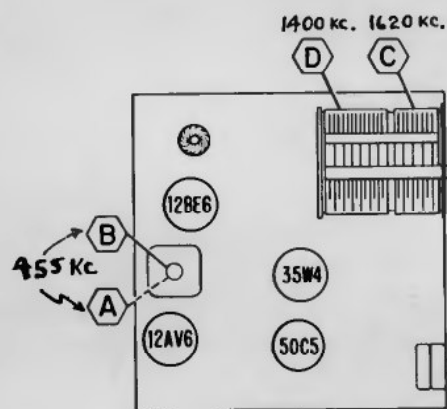
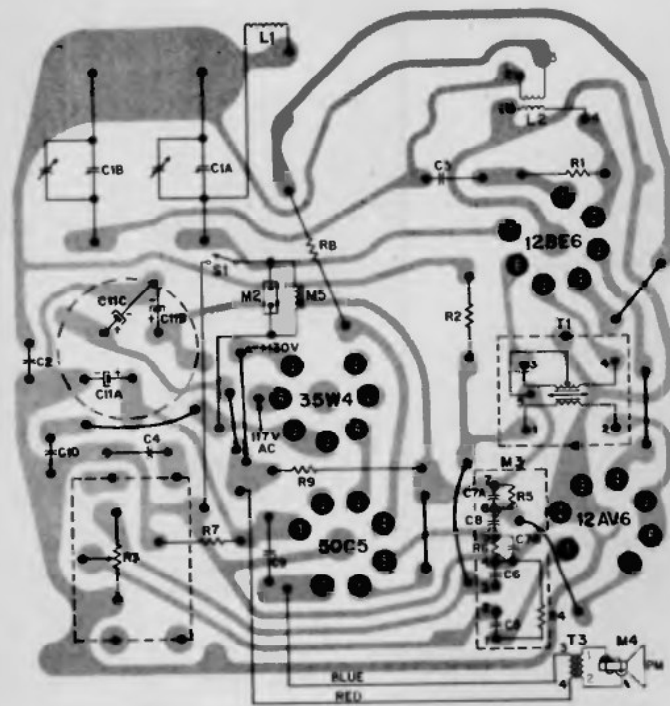

Tube and Alignment Point Locations.

Rear View of Etched Circuit Board, Used in 4E3A Chassis.

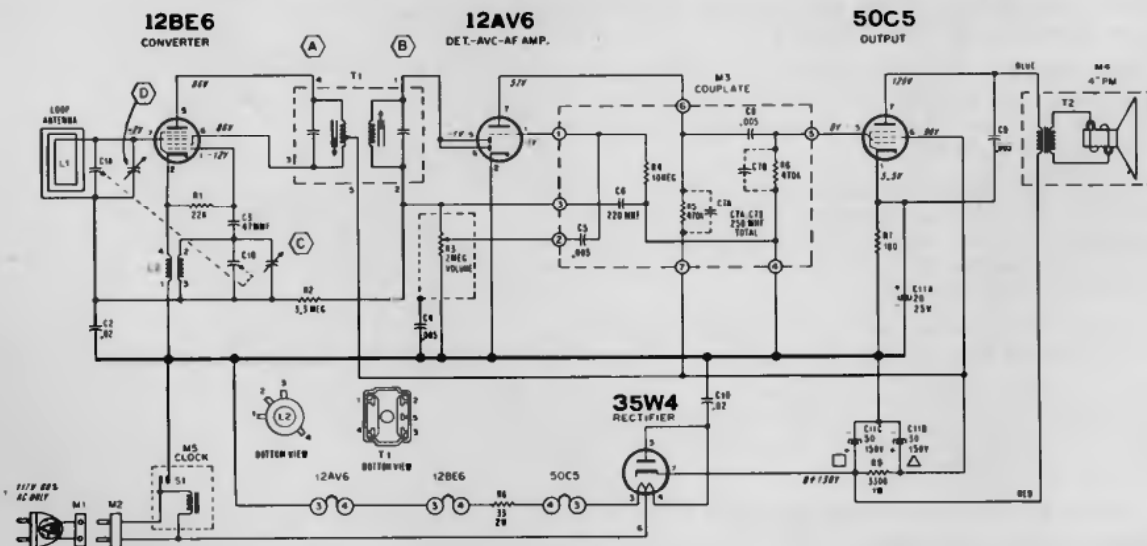

ADMIRAL

Chassis 4F3A

Models Y4057, Y4081,
Y4082, and Y4083

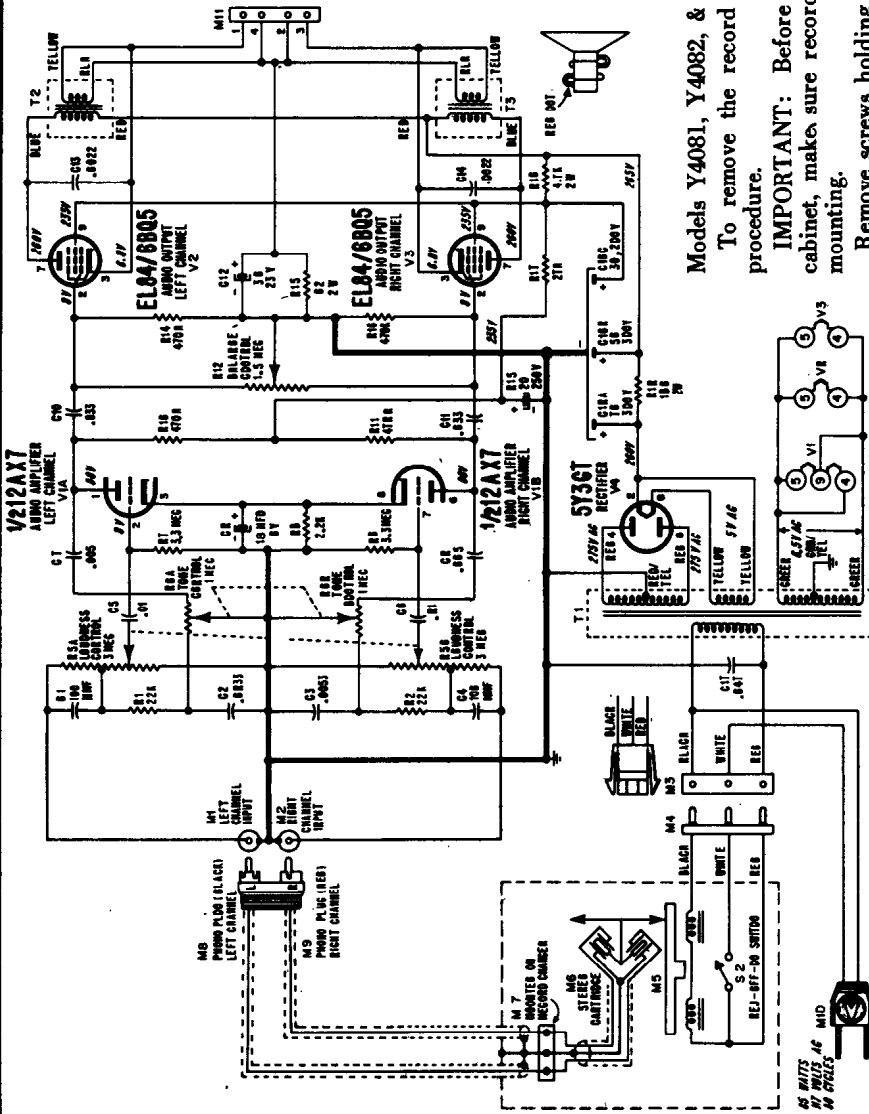
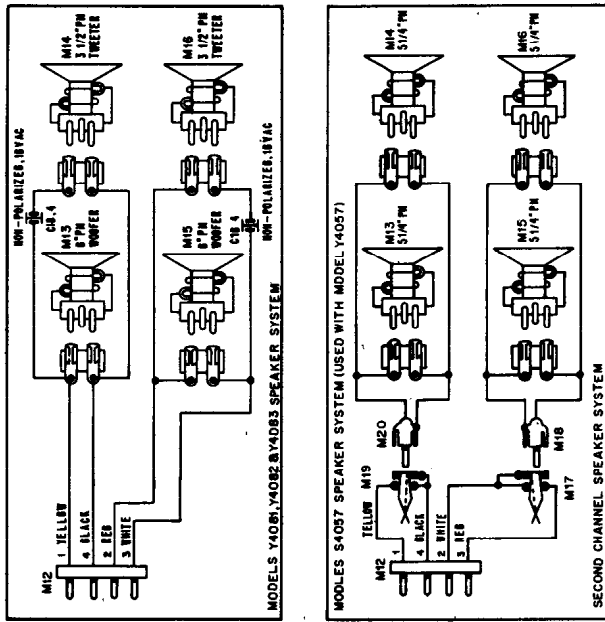

- NOTES
1. ALL RESISTOR VALUES IN OHMS UNLESS CAPACITANCE VALUES IN MICROFARADS UNLESS OTHERWISE SPECIFIED.
 2. ALL VOLTAGES TAKEN WITH A 117V.
 3. PHONO VOLTAGE MEASUREMENTS. ALL CONTROLS AT MIN. ROTATION AND NO SIGNAL APPLIED.
 4. ALL VOLTAGES ARE D.C. UNLESS OTHERWISE INDICATED.
 5. MEASURED WITH RESPECT TO CABINET.
- ± CHASSIS GROUND

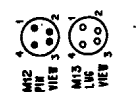

CHANGER REMOVAL

Model Y4057:

- Disconnect line cord. Remove record changer compartment back panel by removing five (5) screws. Lift out panel.
- Remove six motor board mounting screws.
- Disconnect changer phono output plug and changer power plug.
- Remove changer and motor board from cabinet.

Models Y4081, Y4082, & Y4083:

- To remove the record changer, perform the following procedure.
- IMPORTANT:** Before removing record changer from cabinet, make sure record changer "floats" on its spring mounting.
- Remove screws holding the record changer compartment back and record changer bottom cover.
- Speed clips (at bottom of each changer hold down screw) extend through holes in panel under changer. Press clip until it is perpendicular to the changer pan. Remove changer from cabinet for servicing. Disconnect all leads.

CHASSIS REMOVAL

- Disconnect line cord.
- Remove three (3) amplifier control knobs. (Pull knobs straight off from control shafts.)
- Remove record changer compartment back panel by removing screws. Lift out panel.
- Disconnect changer phono output plug, speaker and changer power plug.
- Remove two hexnuts to dismount interlock plug.
- Remove four hexnuts mounting the chassis.
- Lift entire assembly carefully from cabinet.

Admiral

CHASSIS 4L2B, MODELS 4L26B, 4L27B, 4L28B, 4L29B

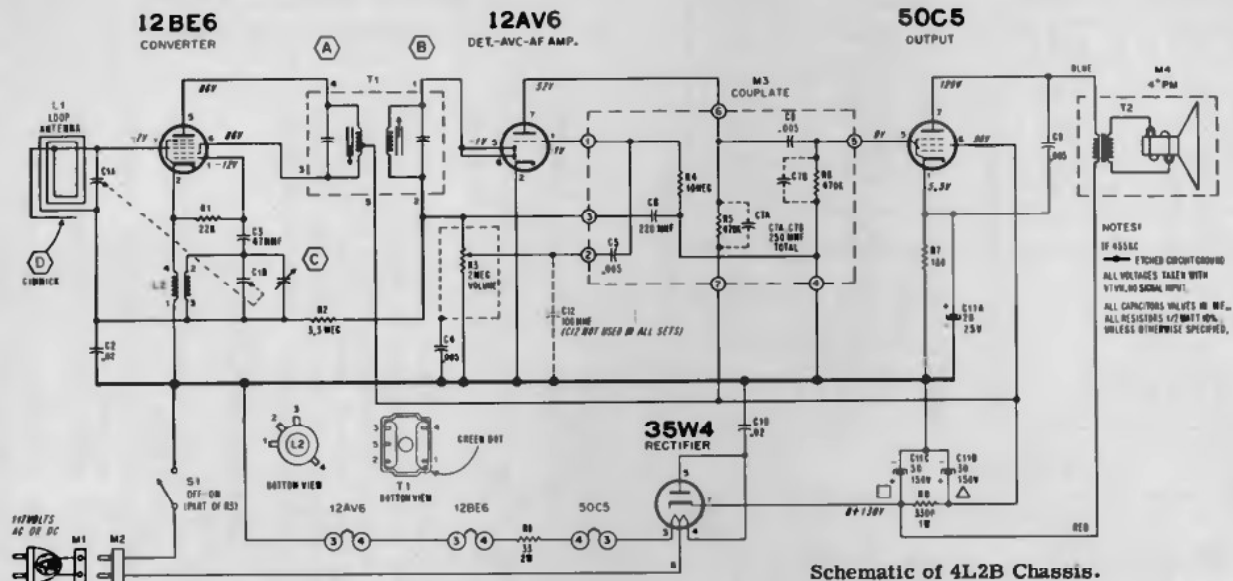

Schematic of 4L2B Chassis.

After start of production of the 4L2B chassis, two components were added to provide better shielding and better RF by-passing in the audio stages.

A metal shield (Admiral part number 15A2267-1) was installed over the audio couplate (M3) with one point soldered to pin No. 4 on the couplate. A 100 mmf capacitor (part number 65D10-154) was added from the center-tap of the volume control (R3) to the etched foil ground.

In some cases this capacitor was installed on the rear of the board and in other cases it was added on component side of board on the Volume control terminals.

The 4L2B chassis is a completely new design of the very popular 4L2 and 4L2A chassis.

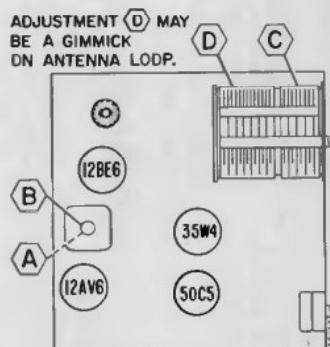

Tube and Alignment Point Locations.

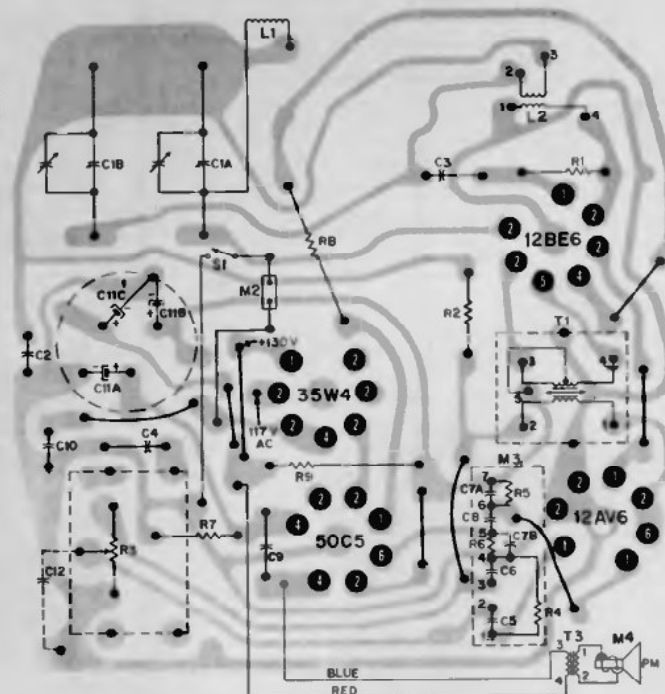

Rear View of Etched Circuit Board, Used in 4L2B Chassis.

ADMIRAL

CHASSIS 4P3

MODELS Y2993, Y2996,
Y2998, and Y2999.

Chassis 4P3A used in Clock
Model Y3037A is identical
except for clock.

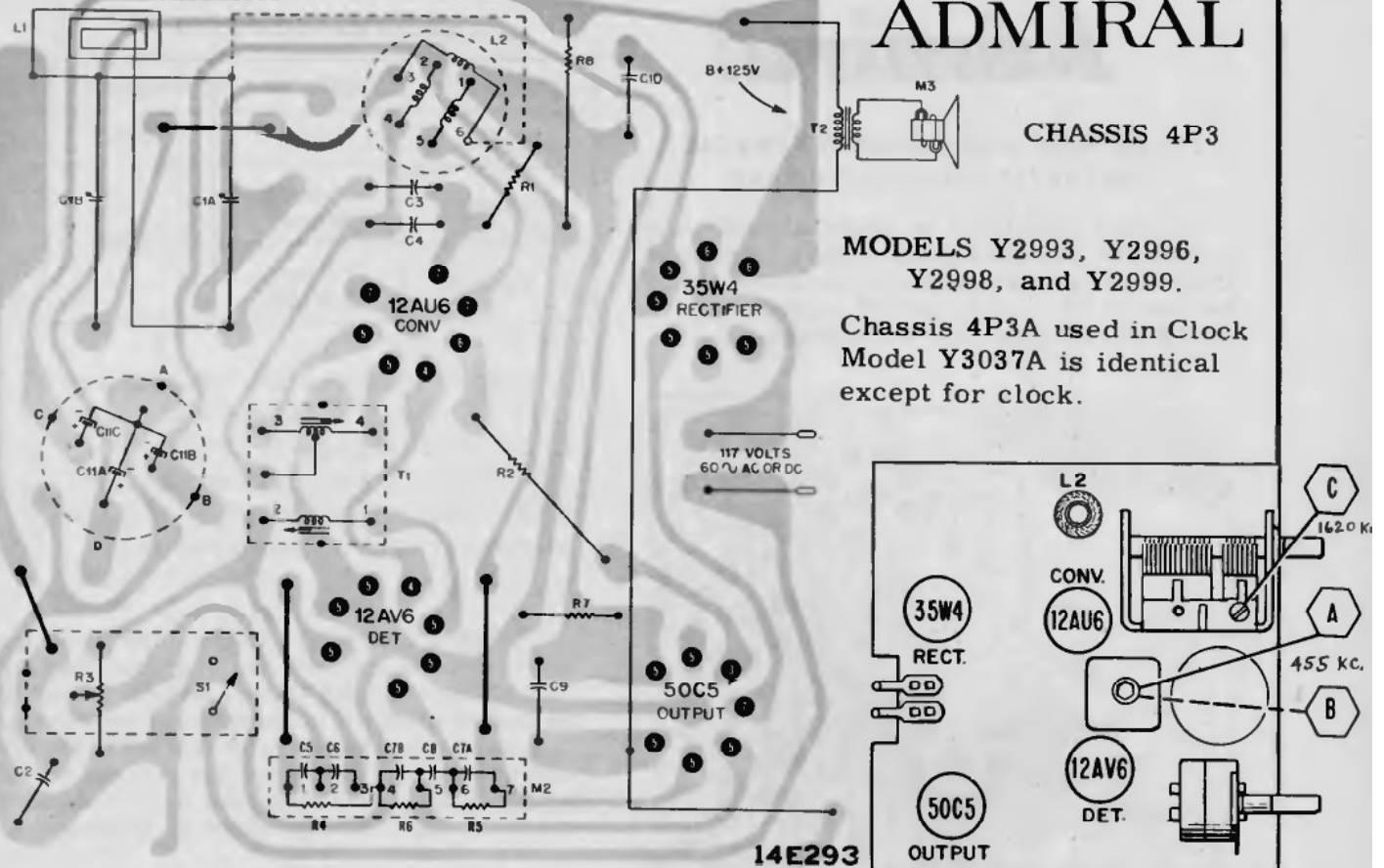

14E293

Rear View of Etched Circuit Board. Gray Area represents etched wiring; black symbols and lines represent components and connections on opposite side.

ALIGNMENT (A) 455 KC, (D) IS AN INSIDE TURN ON LOOP ANTENNA (GIMMICK)

12AU6
CONVERTER

12AV6
DETECTOR-AF AMP.

50C5
OUTPUT

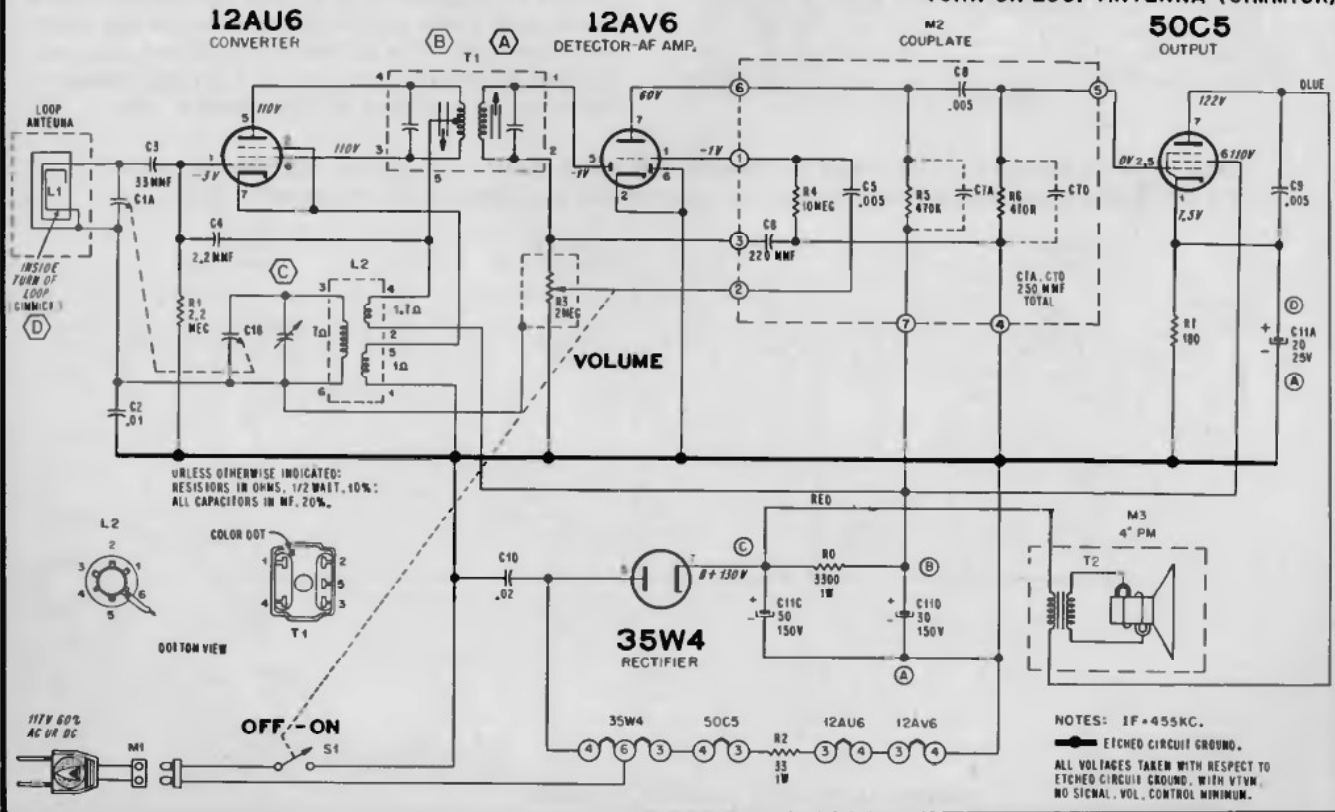

UNLESS OTHERWISE INDICATED:
RESISTORS IN OHMS, 1/2 WATT, 10%;
ALL CAPACITORS IN MF, 20%.



COLOR DOT

OUTLINE VIEW

35W4
RECTIFIER

NOTES: IF = 455 KC.
— ETCHED CIRCUIT GROUND.
ALL VOLTAGES TAKEN WITH RESPECT TO
ETCHED CIRCUIT GROUND, WITH VTVM,
NO SIGNAL, VOL. CONTROL MINIMUM.

Admiral

CORRECTION IN COMPONENT SYMBOLS ON THE ETCHED CIRCUIT BOARD

In some chassis C3 is shown alongside the electrolytic capacitor (C13). This C3 should be deleted. C8 shown on opposite side of C13 should be read as C3. (C8 is part of couplate M3 and should therefore not show on the board.)

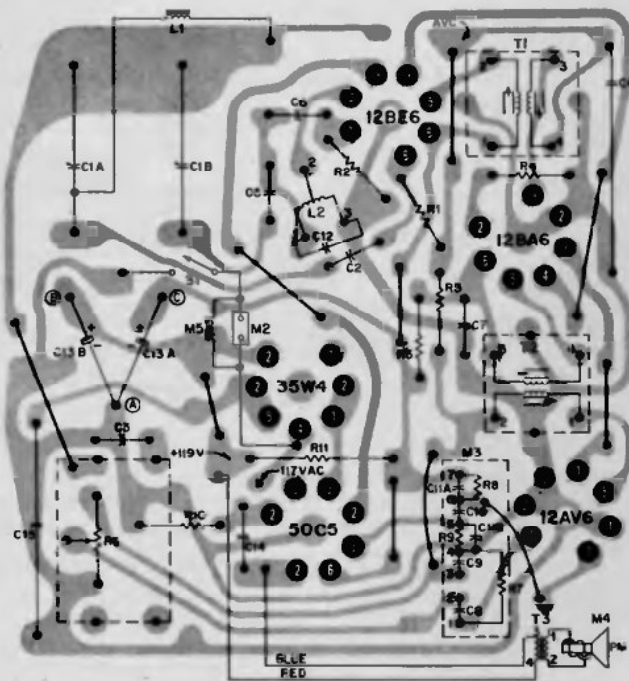

Rear View of Etched Circuit Board in Chassis 5B5B and 5B5C. Gray area represents etched wiring, black symbols and lines represent components and connections on opposite side.

TABLE CLOCK RADIO

MODEL	COLOR	CHASSIS
Y853C	White	5B5C
Y865B	Melon & White	5B5B
Y866B	Yellow & White	

Both 5B5B and 5B5C chassis are very similar to Chassis 5B5, which is covered on page 5, of Vol. 20, 1960 Radio Diagrams manual, and these instructions may be used for alignment and chassis removal.

The 5B5B and 5B5C chassis differ from the 5B5 chassis in the following respects: The RF input is now shunt fed to the converter to reduce the loading effect and noise pickup of the antenna. The tuning gang and oscillator coil have been re-designed and also the IF amplifier bias and screen bypassing have been increased to reduce, to a minimum, any tendency toward IF regeneration.

There are no electrical circuit differences between the 5B5B and 5B5C chassis. The 5B5B chassis is equipped with a clock having the Snooze Alarm and Sleep Switch features while the 5B5C clock does not. The etched circuit board has been changed to comply with the new circuit changes, plus a few relocations of components, etc.

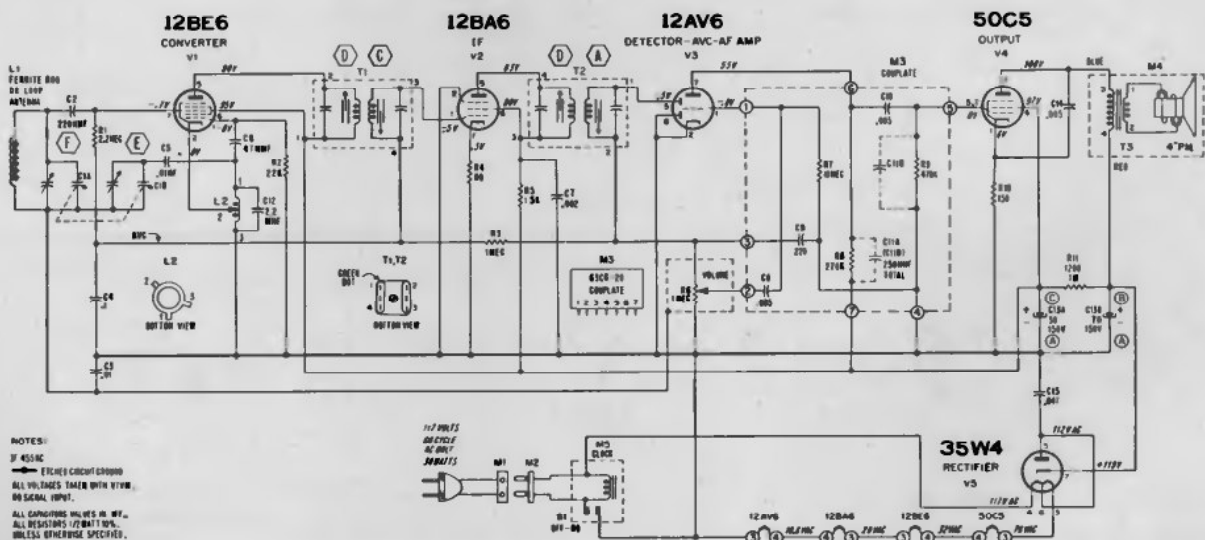

NOTES:
 IF 455KC
 ——— ETCHED CIRCUIT BOARD
 ALL VOLTAGES TAEN WITH RTN. OR SERIAL 00V.
 ALL CAPACITOR VALUES IN MF.,
 ALL RESISTORS 1/2WATT 10%
 UNLESS OTHERWISE SPECIFIED.

Schematic of 5B5B and 5B5C Chassis.

ADMIRAL

1/2 12AX7
LEFT CHANNEL
1ST AUDIO
V1A

1/2 12AX7
LEFT CHANNEL
AUDIO DRIVER
V1B

EL84/6BQ5
LEFT CHANNEL
AUDIO OUTPUT
V2

VOLUME

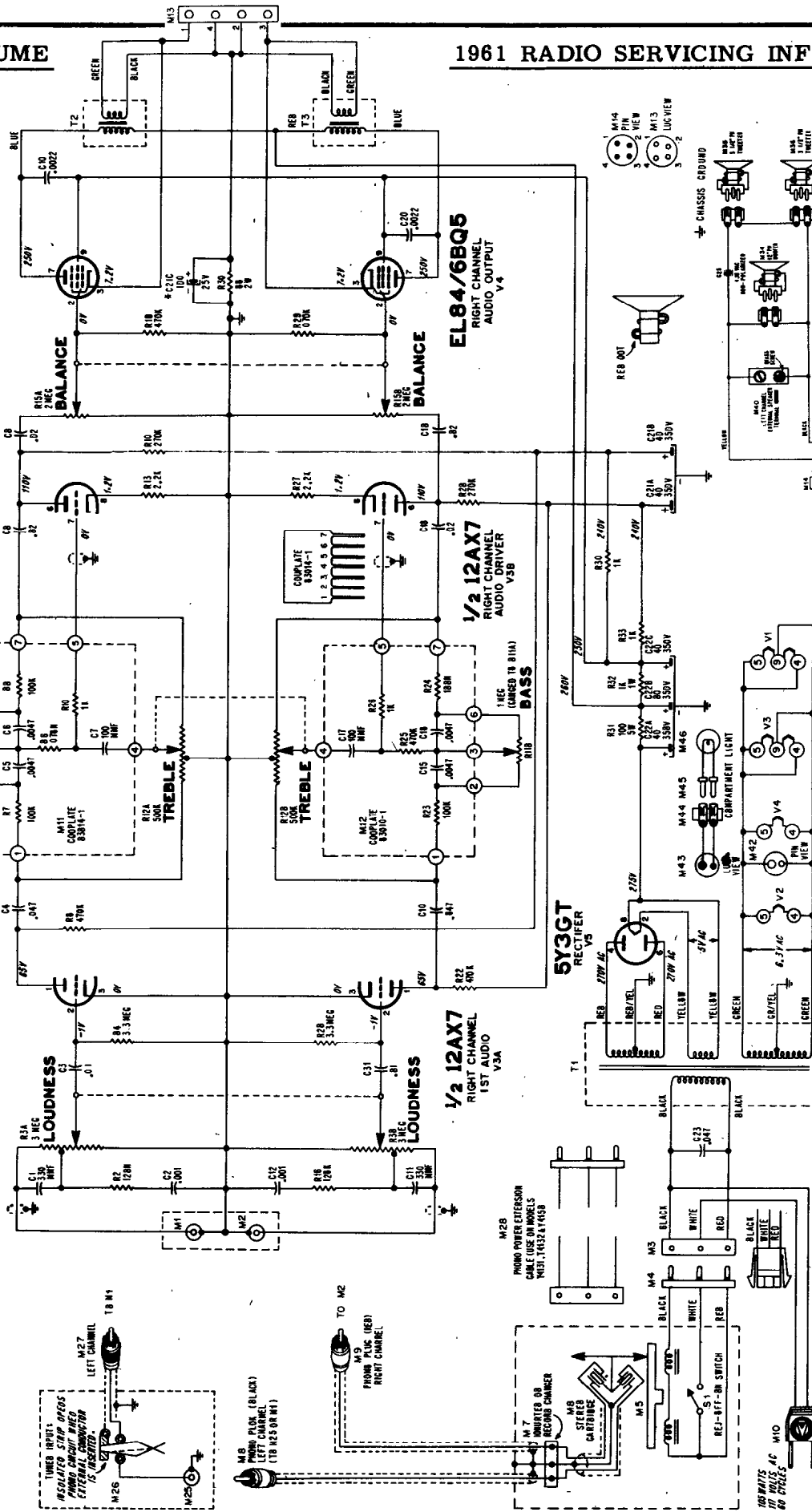

1961 RADIO SERVICING INFORMATION

ADMIRAL

Stereophonic Amplifier Chassis 5K5A, 5K5B, used in Models Y979, Y1002, Y1009, Y1021, Y1022, Y1023, Y4067, Y4131, Y4132, Y4159

- NOTES:
1. ALL RESISTOR VALUES IN OHMS AND CAPACITOR VALUES IN MICROFARADS UNLESS OTHERWISE SPECIFIED.
 2. ALL VOLTAGE READINGS TAKEN WITH A VTVM. ALL CONTROLS AT MID-RANGE AND NO SIGNAL APPLIED.
 3. ALL VOLTAGES ARE DC UNLESS OTHERWISE INDICATED.
 4. VOLTAGE READINGS TAKEN WITH CITY AC LINE INPUT.
 5. * C26 IN EARLY PRODUCTION WAS TWO SWIFT IN PARALLEL.

Admiral

CHASSIS 5M5
MODEL Y4017

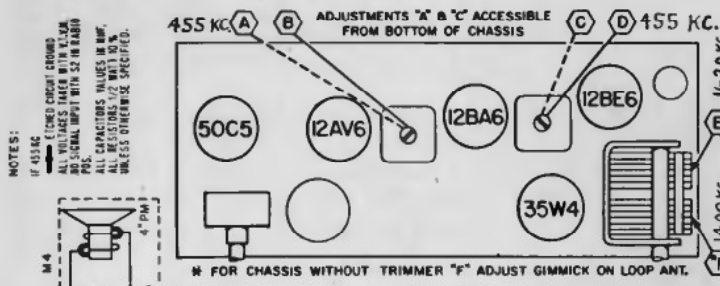

NOTES:
IF 455 KC
IF 455 KC (TUNED CIRCUIT BOARD)
NO. 5000000000
NO. 5000000000
NO. 5000000000
ALL CAPACITORS VALUES IN MICRO-FARADS UNLESS OTHERWISE SPECIFIED.

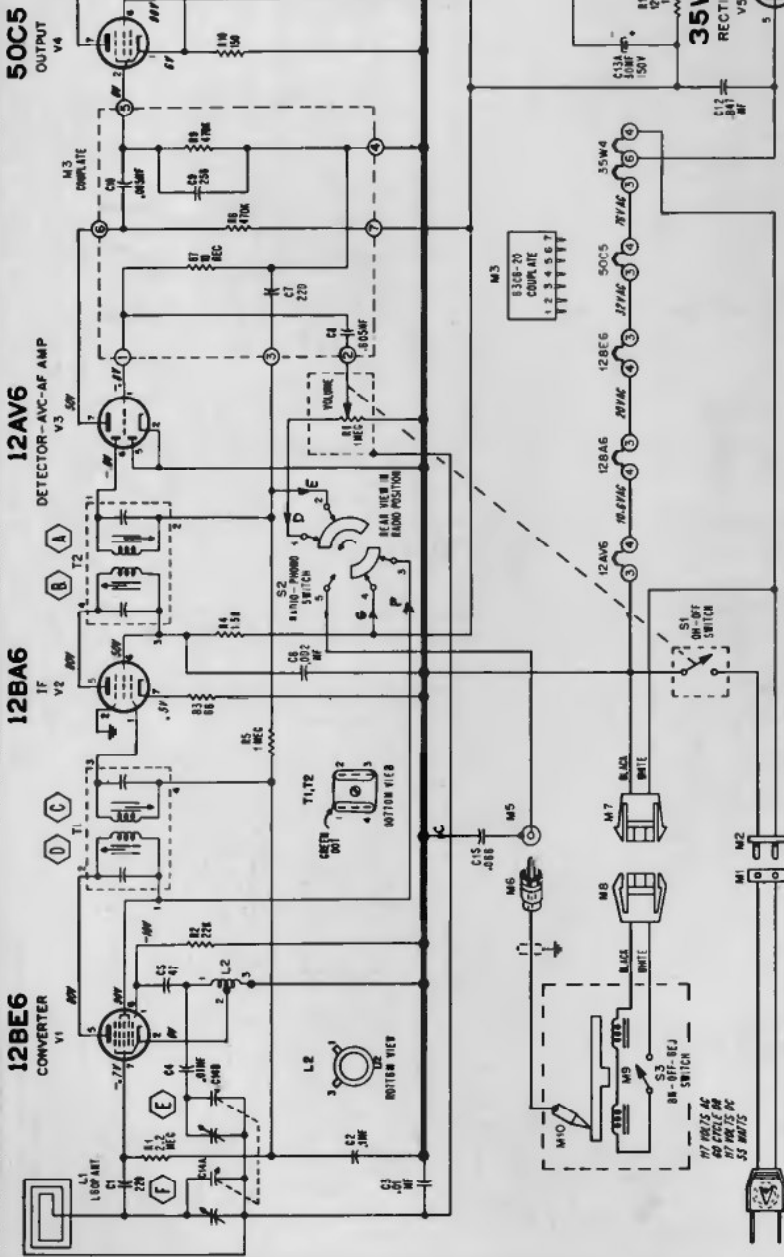

CHANGER REMOVAL

- Disconnect line cord. Remove record changer compartment back panel by removing five (5) screws. Lift out panel.
- Remove six motor board mounting screws.
- Disconnect changer phono output plug and changer power plug.
- Remove changer and motor board from cabinet.

CHASSIS REMOVAL

- Remove three (3) amplifier control knobs. (Pull knobs straight off from control shafts.)
- Remove record changer compartment back panel by removing five (5) screws. Lift out panel.
- Disconnect changer phono output plug and changer power plug.
- Remove two hexnuts to dismount speaker.
- Remove two hexnuts to dismount interlock plug.
- Remove four (4) hexnuts mounting the chassis; located on the antenna mounting board.
- Lift entire assembly carefully from cabinet.

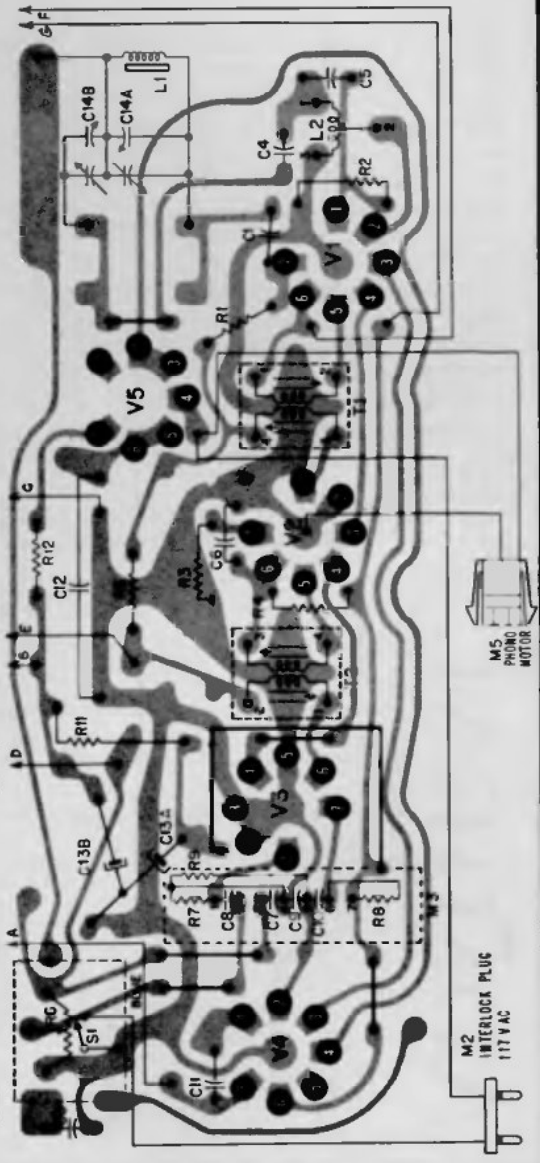

Bottom View of Etched Circuit Board. Gray area represents etched wiring; black symbols and lines represent components and connections on opposite side.

ADMIRAL

CHASSIS 5R5
MODELS Y3021 • Y3027

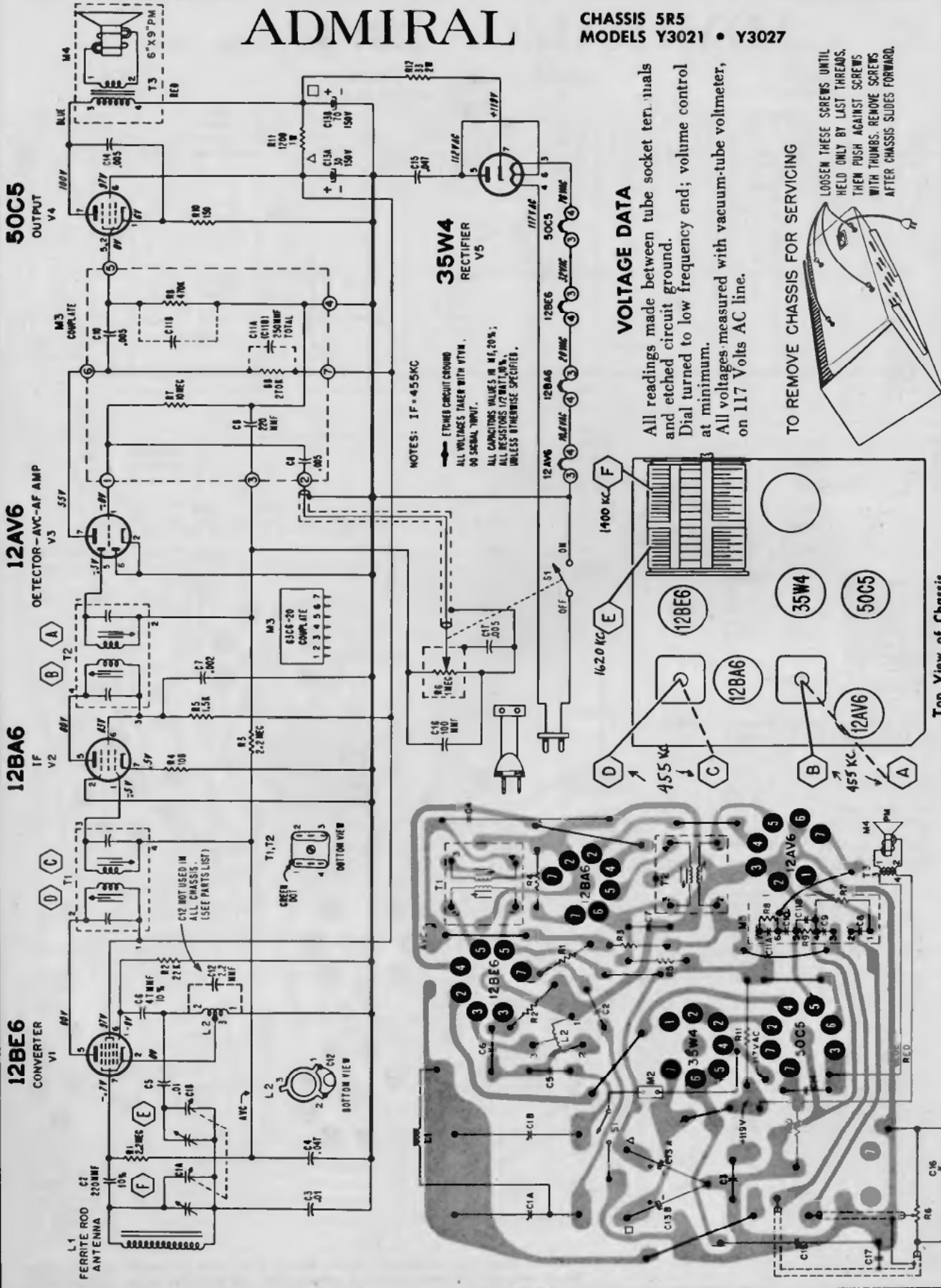

NOTES: IF = 455KC
 ETCHED CIRCUIT BOARD
 ALL VOLTAGES TAKEN WITH VTVM.
 ON SIGNAL INPUT.
 ALL CAPACITORS VALUES IN MF, 20%
 ALL RESISTORS 1/2 WATT, 5%,
 UNLESS OTHERWISE SPECIFIED.

VOLTAGE DATA

All readings made between tube socket terminals and etched circuit ground.
 Dial turned to low frequency end; volume control at minimum.
 All voltages measured with vacuum-tube voltmeter, on 117 Volts AC line.

TO REMOVE CHASSIS FOR SERVICING

LOOSEN THESE SCREWS UNTIL HELD ONLY BY LAST THREADS. THEN PUSH AGAINST SCREWS WITH THUMBS. REMOVE SCREWS AFTER CHASSIS SLIDES FORWARD.

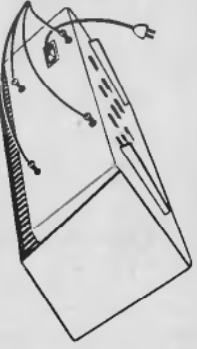

Rear View of Etched Circuit Board. Gray area represents etched wiring; black symbols and lines represent components and connections on opposite side.

ADMIRAL

CHASSIS 555
MODELS Y3046 - Y3048 - Y3049

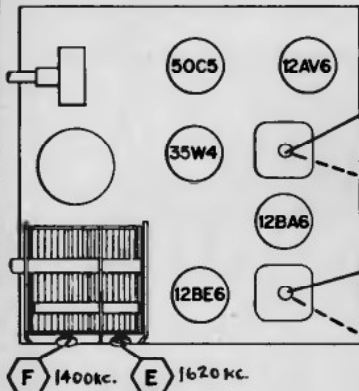
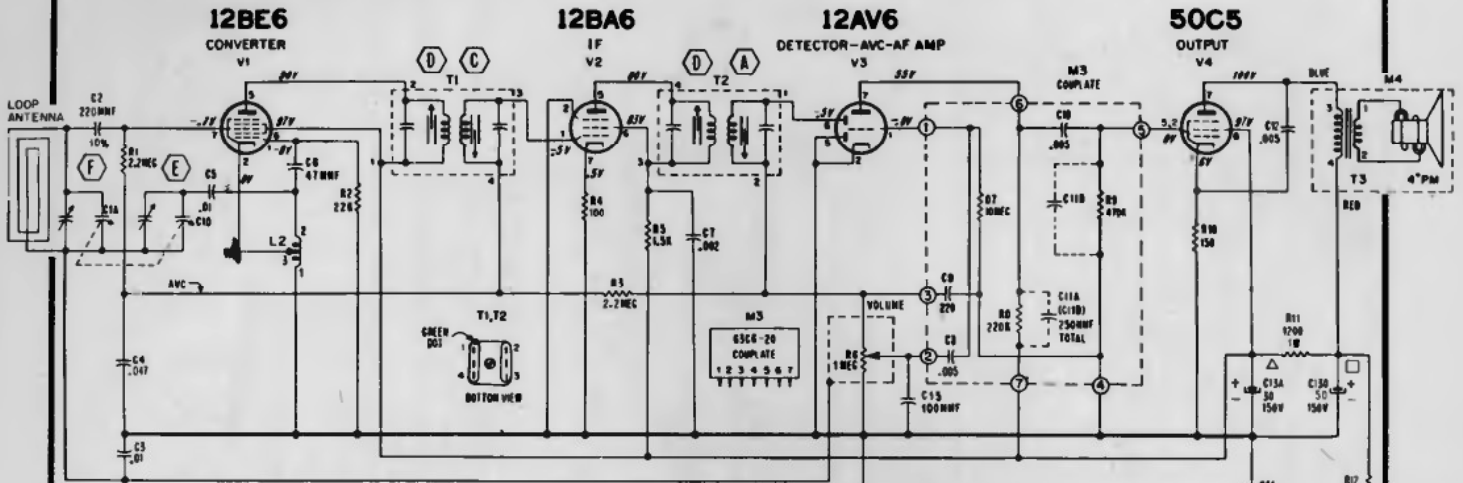

Top View of Chassis Showing Tube and Alignment Point Locations.

NOTES: IF = 455KC

ETCHED CIRCUIT GROUND
ALL VOLTAGES TAKEN WITH VTRM.
NO SIGNAL INPUT.

ALL CAPACITORS VALUES IN MF, 24%,
ALL RESISTORS 1/2WATT, 10%,
UNLESS OTHERWISE SPECIFIED.



TO REMOVE CHASSIS FOR SERVICING TUBES



Rear View of Cabinet Showing Chassis Mounting Screws.

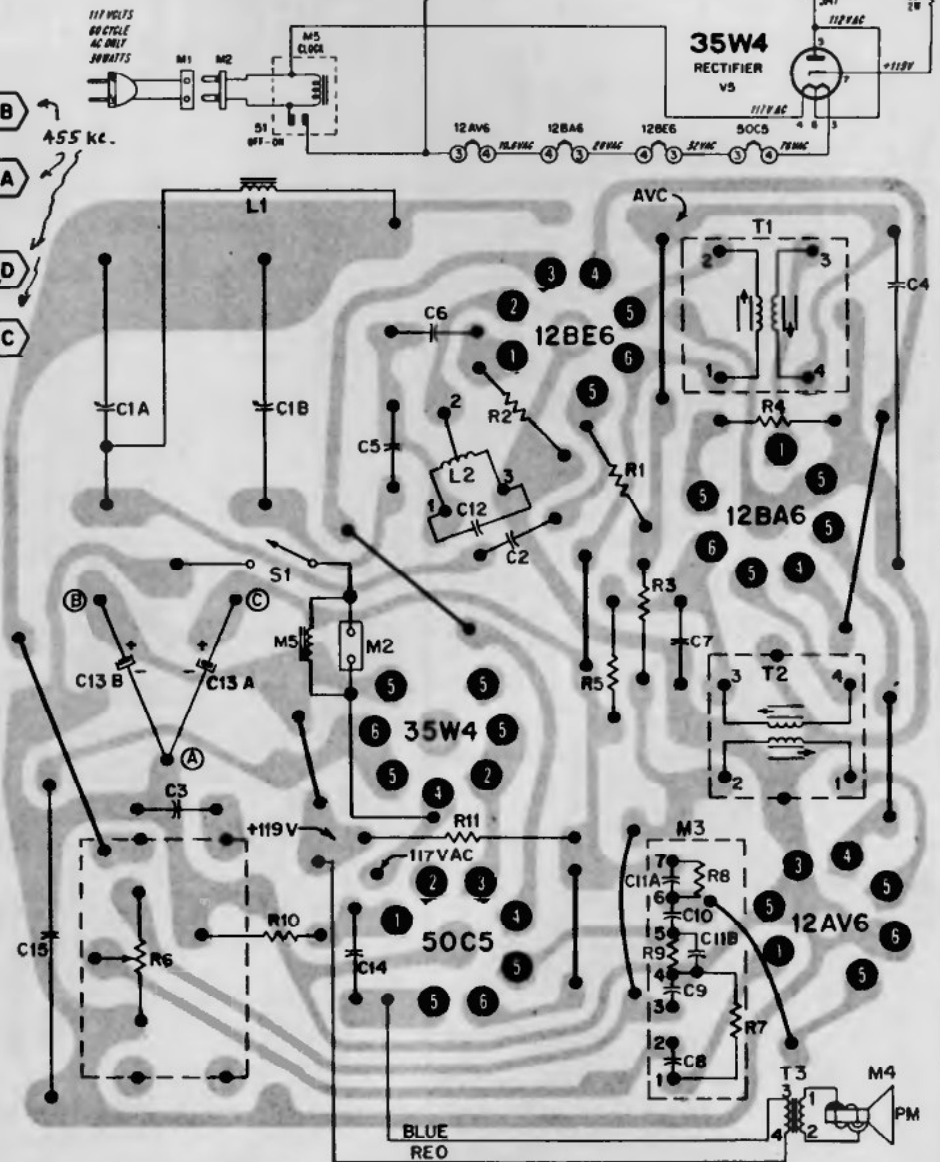

Rear View of Etched Circuit Board. Gray area represents etched wiring; black symbols and lines represent components and connections on opposite side.

ADMIRAL

CHASSIS 5T5 // - Y3058
MODELS Y3051 - Y3053

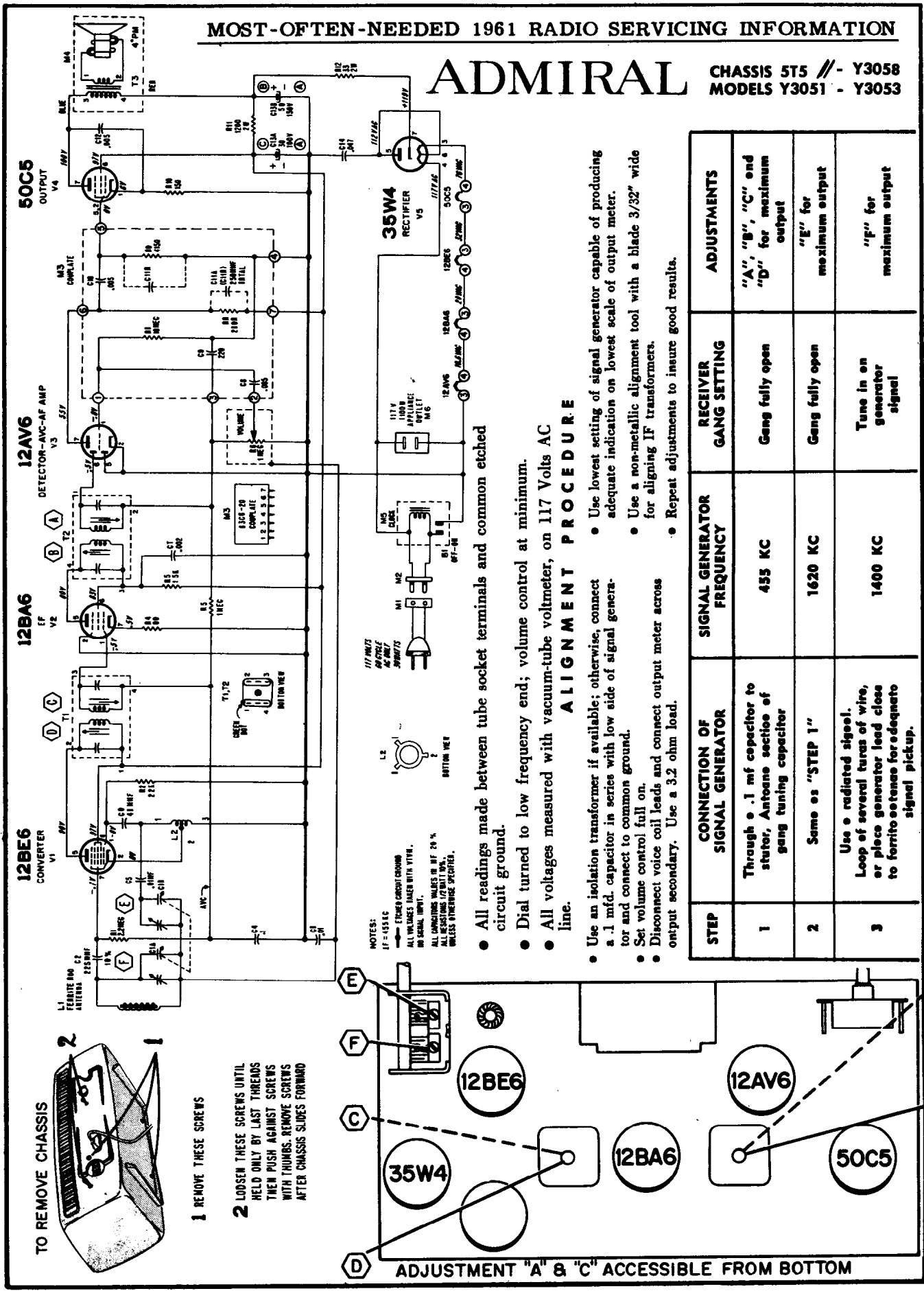

- TO REMOVE CHASSIS**
- 1 REMOVE THESE SCREWS
 - 2 LOOSEN THESE SCREWS UNTIL HELD ONLY BY LAST THREADS THEN PUSH AGAINST SCREWS WITH THUMBS. REMOVE SCREWS AFTER CHASSIS SLIDES FORWARD

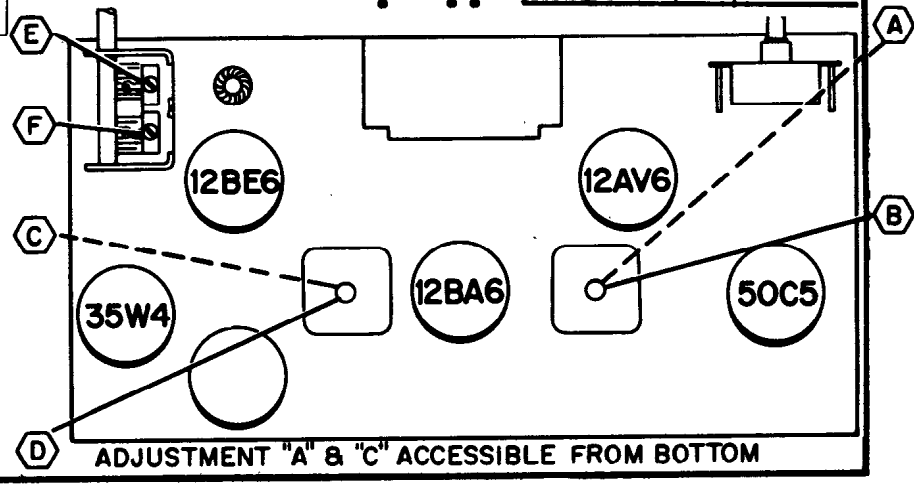

ADJUSTMENT "A" & "C" ACCESSIBLE FROM BOTTOM

- ALIGNMENT PROCEDURE**
- All readings made between tube socket terminals and common etched circuit ground.
 - Dial turned to low frequency end; volume control at minimum.
 - All voltages measured with vacuum-tube voltmeter, on 117 Volts AC line.
 - Use an isolation transformer if available; otherwise, connect a .1 mfd. capacitor in series with low side of signal generator and connect to common ground.
 - Set volume control full on.
 - Disconnect voice coil leads and connect output meter across output secondary. Use a 3.2 ohm load.
 - Repeat adjustments to insure good results.

STEP	CONNECTION OF SIGNAL GENERATOR	SIGNAL GENERATOR FREQUENCY	RECEIVER GANG SETTING	ADJUSTMENTS
1	Through a .1 mf capacitor to stator, Antenna section of gang tuning capacitor	455 KC	Gang fully open	"A", "B", "C" and "D" for maximum output
2	Same as "STEP 1"	1620 KC	Gang fully open	"E" for maximum output
3	Use a radiated signal. Loop of several turns of wire, or piece generator lead close to ferrite core for adequate signal pickup.	1400 KC	Tune in on generator signal	"F" for maximum output

NOTES:
IF = 455 KC
ETHER CIRCUIT COUPLER
ALL VALUES TAKEN WITH VITH.
NO SIGNAL INPUT.
ALL CAPACITORS VALUES IN MF UNLESS OTHERWISE SPECIFIED.



R-21, MOST-OFTEN-NEEDED 1961 RADIO SERVICING INFORMATION

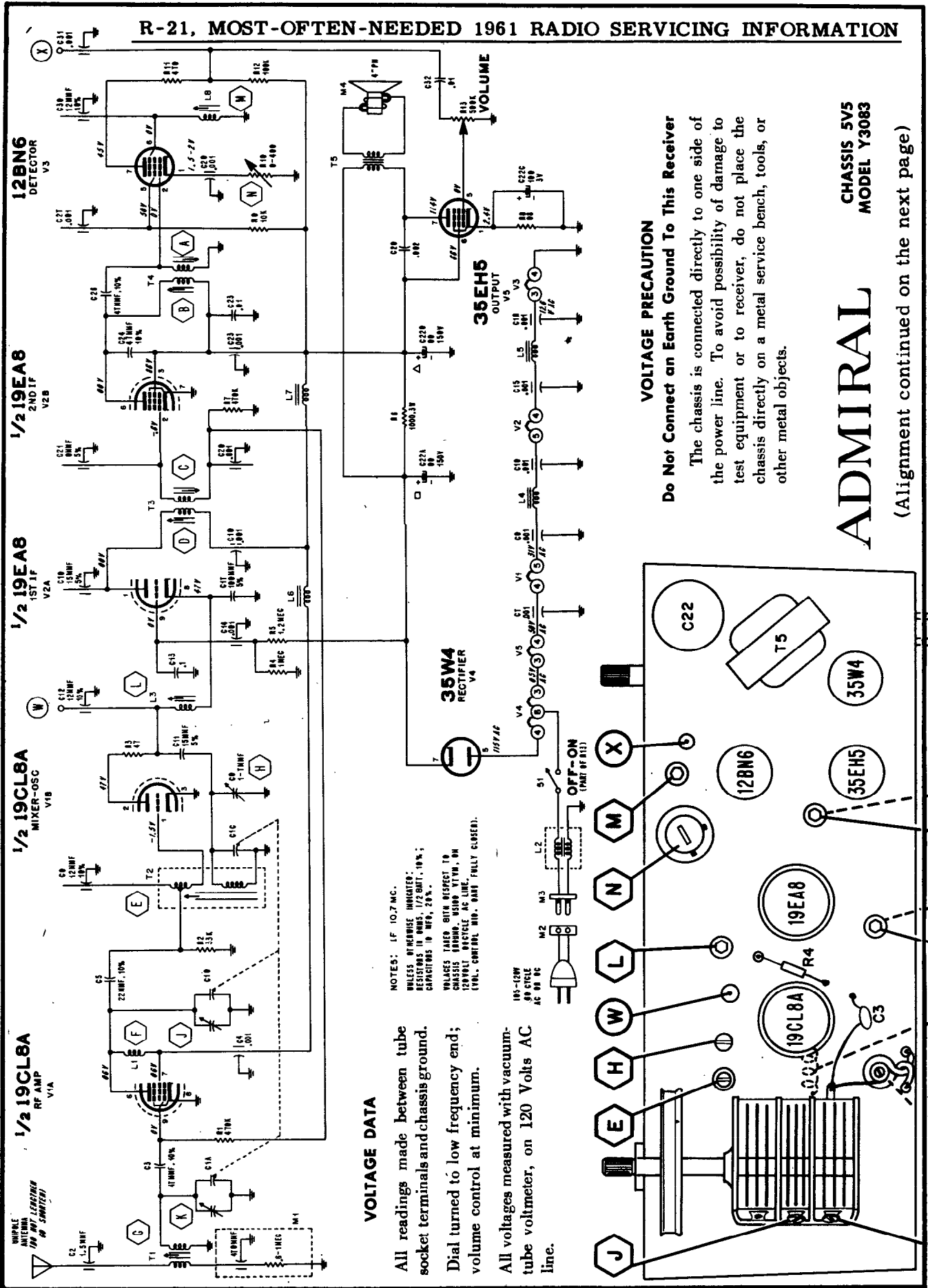

VOLTAGE DATA

All readings made between tube socket terminals and chassis ground. Dial turned to low frequency end; volume control at minimum.

All voltages measured with vacuum-tube voltmeter, on 120 Volts AC line.

NOTES: IF 10.7 MC. UNLESS OTHERWISE INDICATED: RESISTORS IN OHMS, 1/2 OHM, 10%; CAPACITORS IN MFD, 20%.

VALUES IN PARENTHESIS REFER TO CONTROL PANEL SWITCHES, IN SPECIAL CASES. CONTROL PANEL SWITCHES FULLY CLOSED.

VOLTAGE PRECAUTION
Do Not Connect an Earth Ground To This Receiver

The chassis is connected directly to one side of the power line. To avoid possibility of damage to test equipment or to receiver, do not place the chassis directly on a metal service bench, tools, or other metal objects.

ADMIRAL
CHASSIS 5V5
MODEL Y3083
(Alignment continued on the next page)

DASHED LINE INDICATES ADJUSTMENT FROM UNDERSIDE OF CHASSIS

ADMIRAL

CHASSIS 5V5, MODEL Y3083
Alignment Procedure, Continued

ALIGNMENT USING AM SIGNAL GENERATOR AND VTVM

- Allow set and test equipment to warm up for approximately 15 minutes before alignment.
 - Use an isolating transformer or insert a .01 mfd capacitor in series with the high side of signal generator. **DO NOT CONNECT AN EARTH GROUND TO THIS RECEIVER.**
 - Connect a short wire jumper from the center point of C30 to chassis. (To short L8 to chassis ground.)
 - Set signal generator for 400 or 1000 cycle modulation, 30%. Set volume control full on. Keep signal generator output low to prevent overloading.
 - Turn bias control, (R10) to full counterclockwise position (maximum bias point).
 - Connect the VTVM across output transformer secondary (voice coil leads). Use the 1.5 volt AC scale for output readings.
- NOTE: If available, a commercial output meter is more desirable for this purpose. Disconnect voice coil leads and use a 3.2 ohm load.
- Use nonmetallic alignment tools. Use hex tool (Admiral part no. 98A30-7) for transformer adjustment slugs.

STEP	SIGNAL GENERATOR CONNECTION	SIGNAL GENERATOR FREQUENCY	RECEIVER GANG SETTING	ADJUSTMENT FOR MAXIMUM
1	Test Point W (Center Point of C12)	10.7 MC	Fully open	A, B, C, and D
2	Set trimmers J and K one turn from tight. Set adjustment screw (H) 1/2 inch above chassis.			
3	Antenna. (Center point of C2 through 75 ohm resistor.)	87.5 MC	Fully closed (set indicator dial on end mark)	E, *F, and G
4	Same as step 3	108 MC	108 MC	H, J, K and L
5	Same as step 3	87.5 MC	Fully closed	Touch-up E
6	Same as step 3	108 MC	108 MC	Touch-up H, J and K
7	a. Set up equipment as in step 1 above. b. Remove short across L8 and adjust M for maximum output. c. Adjust N (R10, starting from full clockwise position) to the first point of maximum sound. Use weakest signal possible.			
7 op.	OPTIONAL METHOD FOR STEP 7 a. Disconnect signal generator from receiver. b. Remove wire jumper from across L8 (C30 to chassis ground). c. Tune in a very weak signal, or reduce signal level, until a strong hiss is heard in the sound. (If necessary coil up antenna in a ball or short antenna lead to chassis or both.) d. Adjust M (quadrature coil, L8) for maximum output. e. Adjust N (R10) for maximum output and clearest tone.			

IF ALIGNMENT CHECK USING SWEEP GENERATOR AND OSCILLOSCOPE

- | | |
|---|--|
| <ul style="list-style-type: none"> a. Use the same equipment setup as in step 1 but add the oscilloscope (vert. input) connected to test point "X". b. Use a wideband sweep, unmodulated for response check, except the final adjustment given in step e. c. Sweep generator signal injected at the same points as given in steps above. | <ul style="list-style-type: none"> d. Oscilloscope pattern should be a typical response curve. Adjust as in step 1 for best symmetry as well as maximum gain. e. Final Adjustment: With generator connected as in step 4, and dial set to 108 MC; use ±75 KC sweep and 400 cycle modulation. Remove short from across L8. Adjust M and N for maximum output, using minimum signal input. |
|---|--|

*Coil (L3) is adjusted by squeezing or spreading turns of the coil.

CHASSIS REMOVAL

To remove the chassis from the cabinet it is necessary to remove only the rear cabinet section, since the front panel and knobs are attached to the chassis.

1. Turn set bottom side up and using a screw driver,

force chassis forward by pushing on the front panel section visible through the elongated chassis mounting holes. A small elevation is provided on the section of the panel inside this slot for this purpose. After the AC interlock connection has been broken, the chassis with the front panel attached will slide forward easily and out of the rear section.

Admiral

CHASSIS 7A2

MODELS Y2061 • Y2063 • Y2067 • Y2068

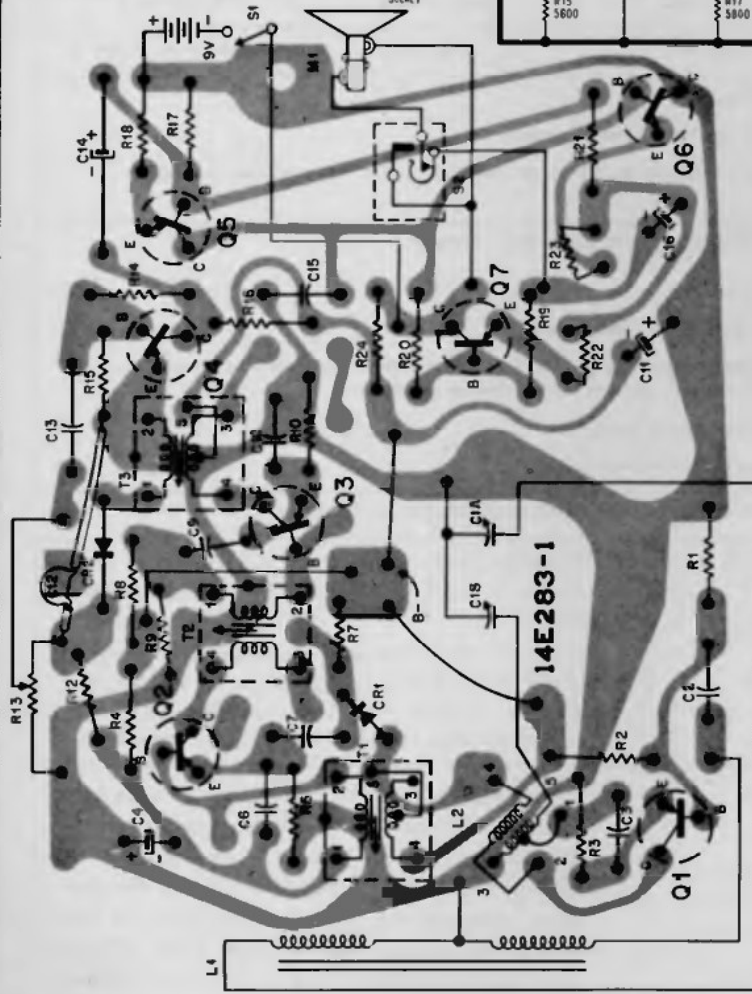
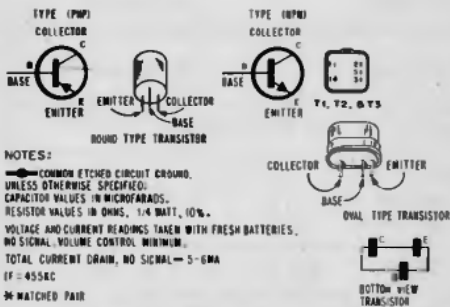
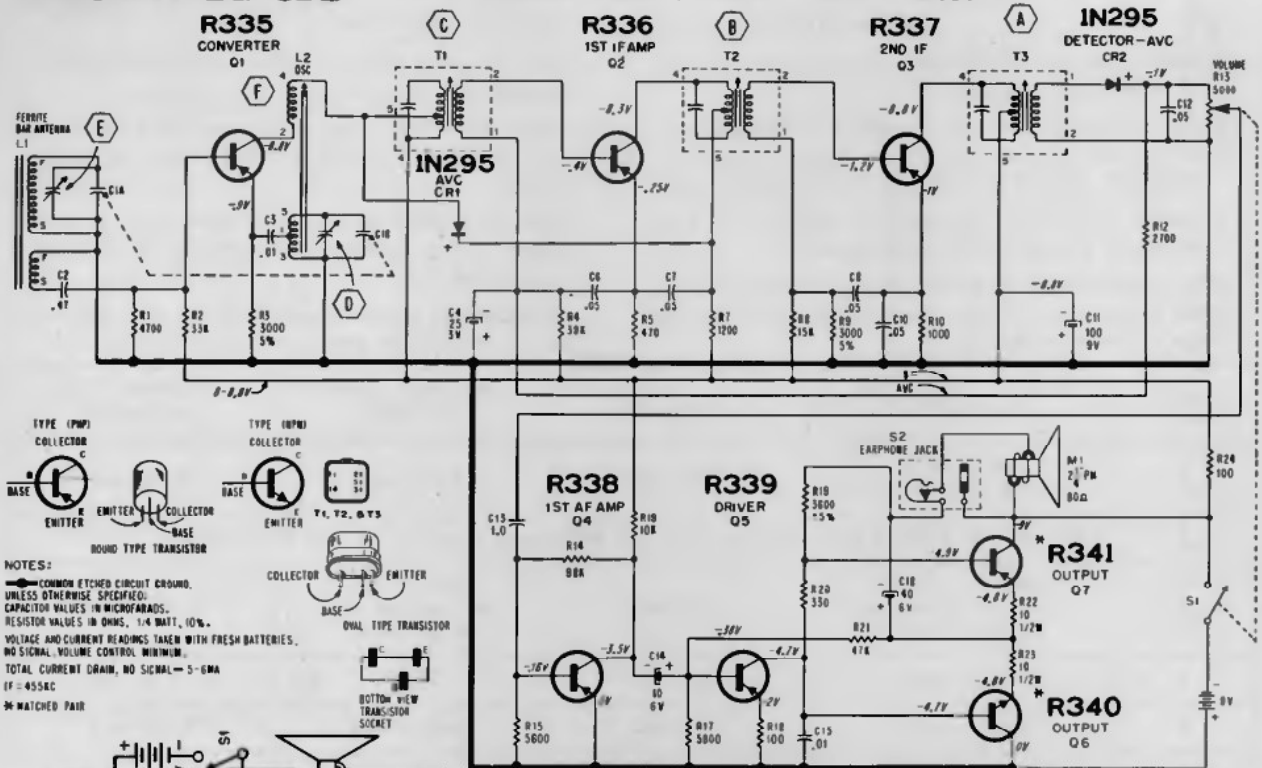

Rear View of Etched Circuit Board. Gray area represents the etched wiring; block symbols and lines represent components and connections on opposite side.

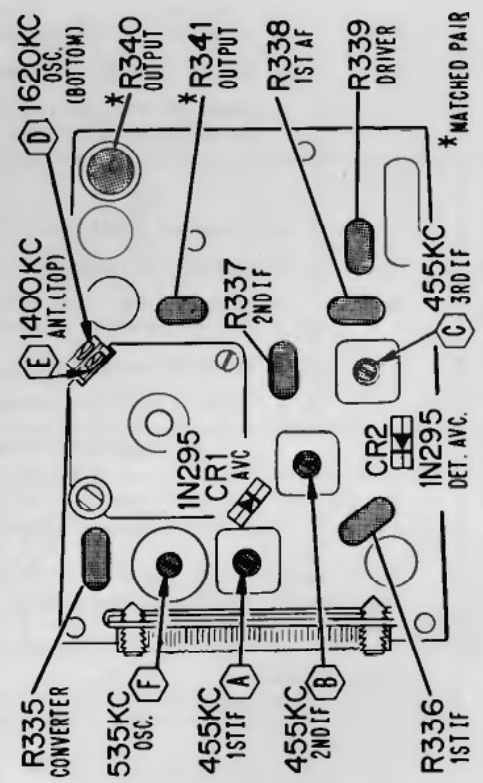

REMOVING CHASSIS FROM CABINET

Remove the three Phillips head screws securing the etched circuit board to the front case.

Transistor and Alignment Point Locations

Admiral

CHASSIS 7D2
MODEL Y2119

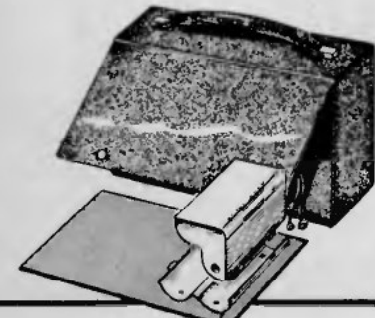
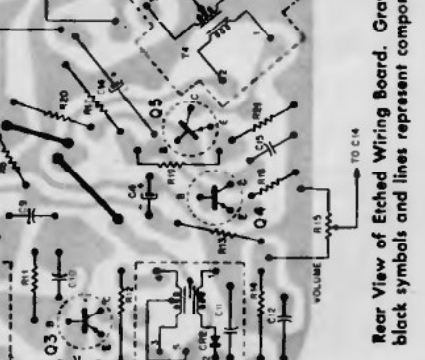
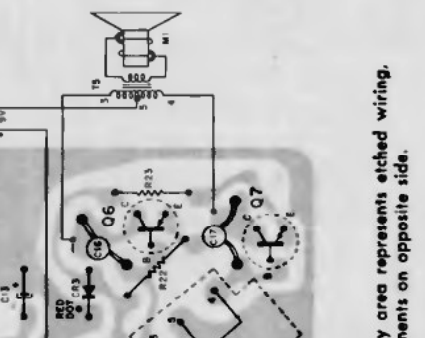
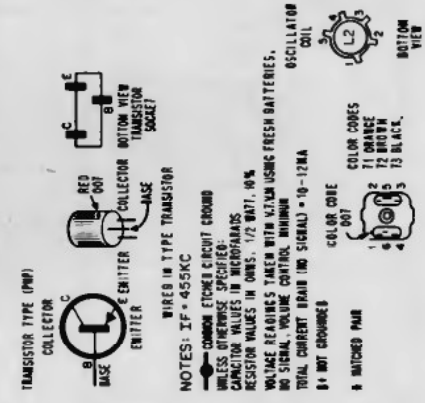
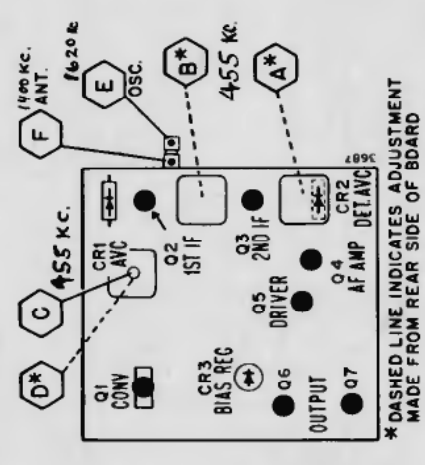
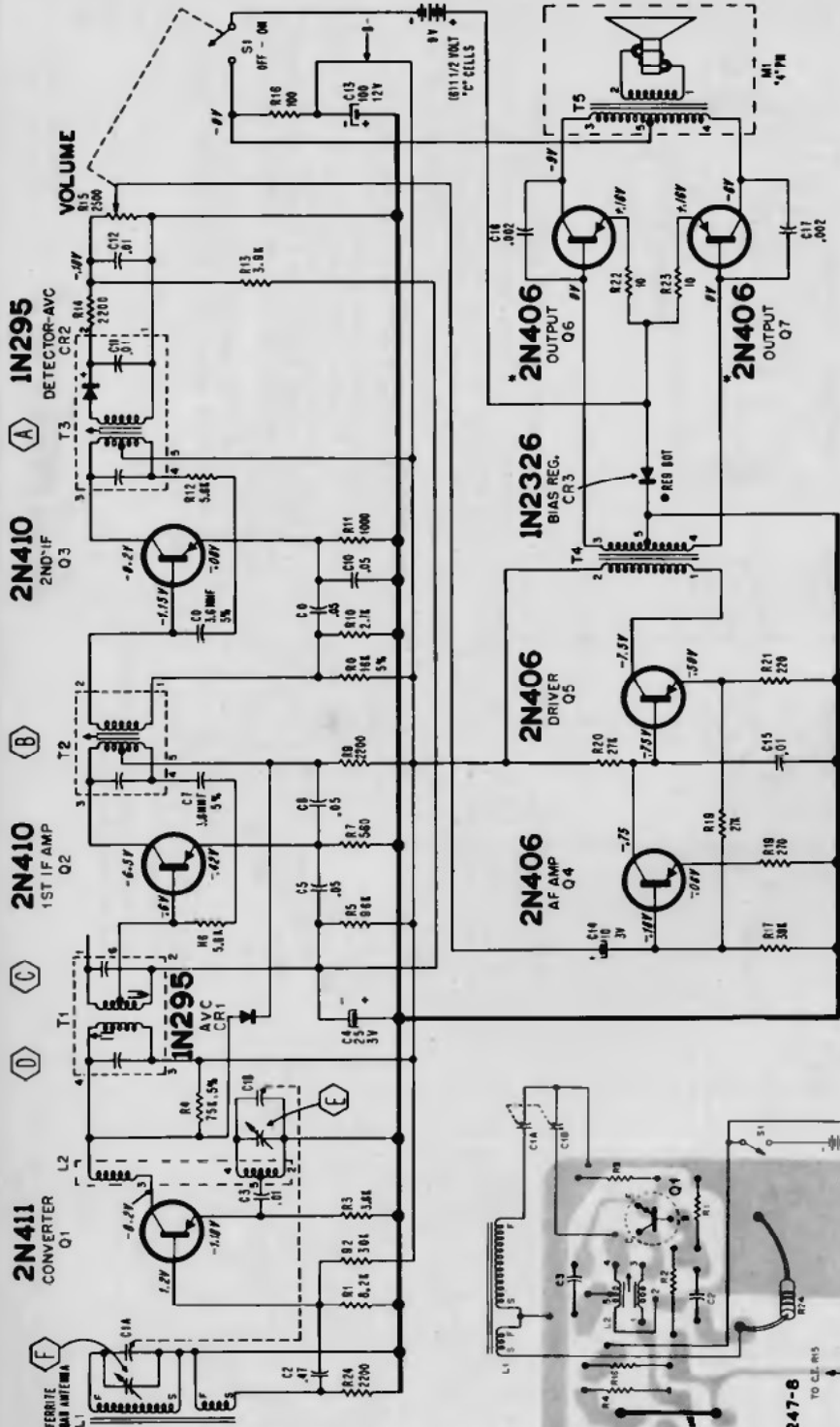

Rear View Showing Battery Case Removed.

NOTES: 1. COMMON ETCHED CIRCUIT GROUND
2. UNLESS OTHERWISE SPECIFIED, RESISTOR VALUES IN OHMS; 1/2 WATT; 5% TOLERANCE. VOLTAGE READINGS TAKEN WITH SIGNAL USING FRESH BATTERIES. NO SIGNAL, VOLUME CONTROL, MINIMUM TOTAL CURRENT DRAIN (NO SIGNAL) = 10-12 MA.
3. * NOT GROUNDED
4. SWITCHED PAIR
5. COLOR CODES
6. 11 ORANGE
7. 2 BROWN
8. 5 RED
9. 3 BLACK
10. OSCILLATOR COIL
11. TRANSISTOR SOCKET
12. BOTTOM VIEW

Rear View of Etched Wiring Board. Gray area represents etched wiring. Black symbols and lines represent components on opposite side.

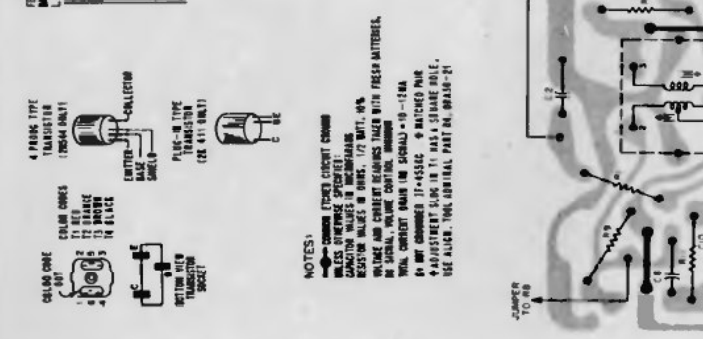
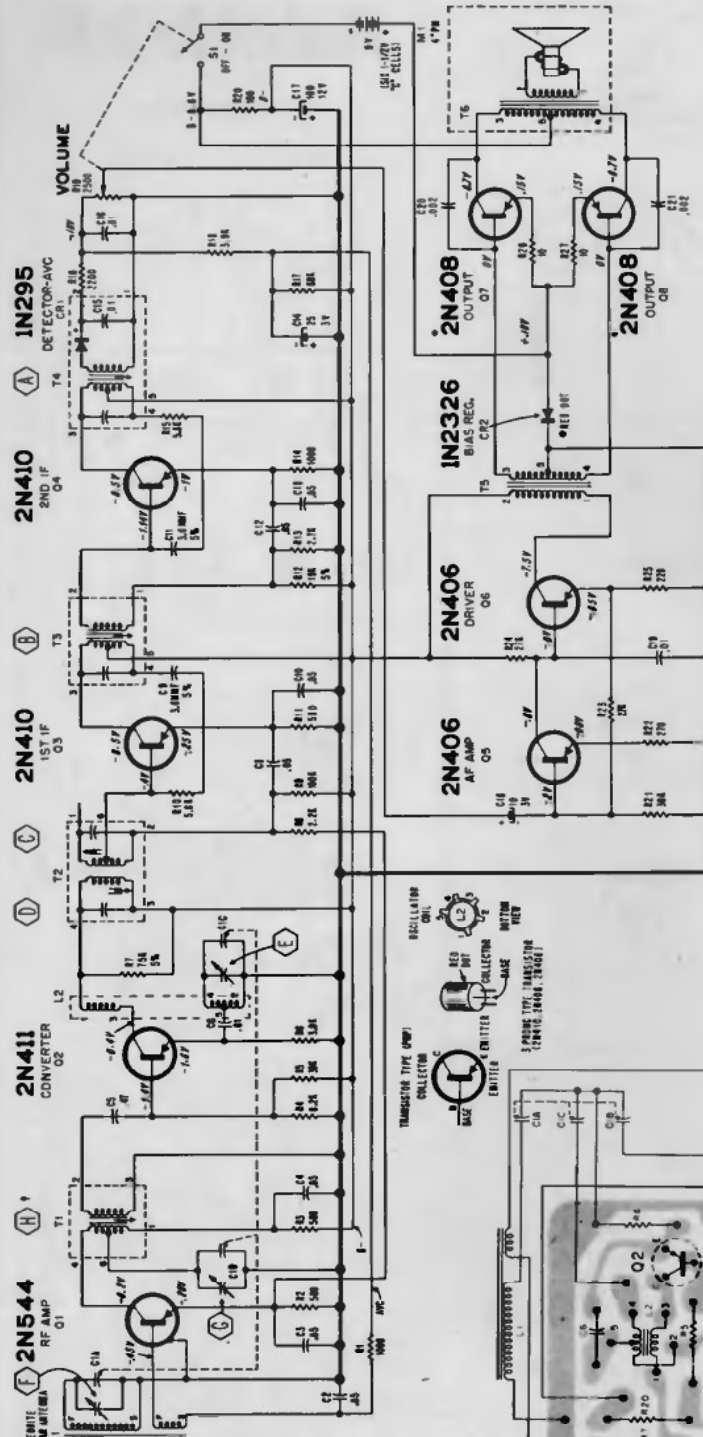

REMOVING CHASSIS FROM CABINET

1. Remove the two knobs plus the two chassis mounting screws at the bottom of the cabinet, if used.
2. Unsnap back cover and remove battery case.
3. Remove the two nuts at the right corners of the chassis.
4. Keeping one hand on front escutcheon, slide chassis to right to remove from cabinet.

NOTE: The left side of the chassis (from rear) is held only by two flanges on the escutcheon.

WARNING: NEVER ALLOW THE BATTERY CONNECTORS ON BATTERY HOLDER TO COME IN CONTACT WITH THE METAL CHASSIS.

The contact of the negative clip to the metal chassis, even with the set turned off, can damage the "Battery Miser" diode.

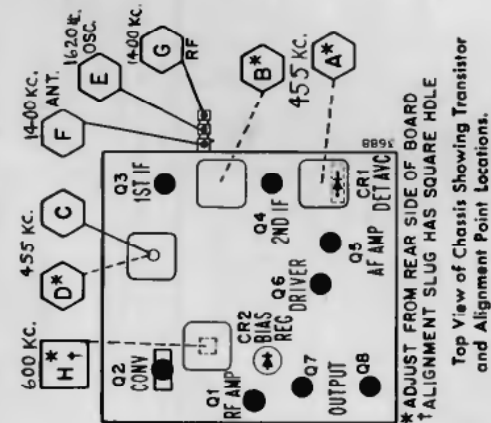

Admiral

MODEL Y2127
CHASSIS 8D2

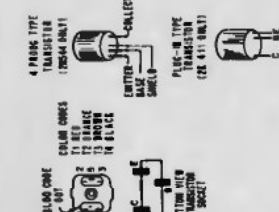

NOTES:

- 1. CHECK THESE CIRCUIT VALUES UNLESS OTHERWISE SPECIFIED.
- 2. RESISTOR VALUES: R, OHMS; RT, 10% RESISTOR VALUE; K, KILOHMS; M, MEGOHMS.
- 3. CAPACITOR VALUES: P, PICO FARADS; U, MICRO FARADS; M, MILLI FARADS; C, CENTI FARADS.
- 4. IF ANY COMPONENT IS 455KC. SWITCHED PULSE.
- 5. ADJUSTMENT SLUG IN T1 HAS SQUARE HOLE. USE ALIAS. THE OPPOSITE PART IN BRASS-21.

Rear View of Etched Wiring Board. Gray area represents etched wiring, black symbol and lines represent components on opposite side.

ARVIN RADIO MODELS 10R16 10R18 CODE 1.42202

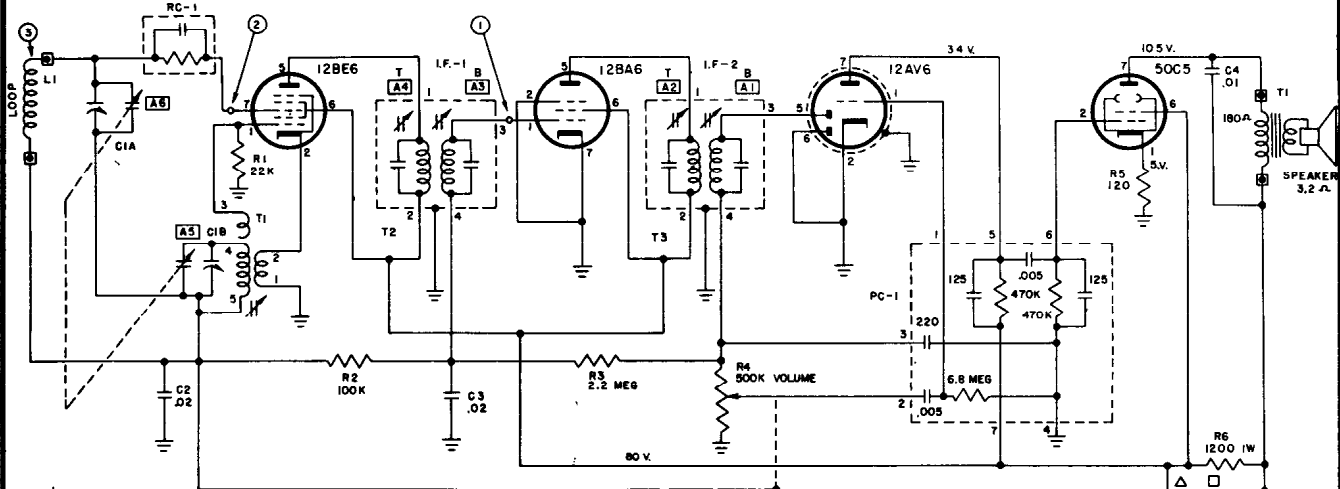

⊕ - B -
 ⊕ - EXTERNAL CONNECTIONS TO PRINTED BOARD.
 VOLTAGES MEASURED WITH A V.T.V.M.

RESISTANCE VALUES ARE IN OHMS K=1,000, MEG=1,000,000.
 CAPACITANCE VALUES LESS THAN (1) ARE IN MICROFARADS (μF),
 AND VALUES OF (1) OR GREATER ARE IN MICROMICROFARADS
 (μμF), UNLESS OTHERWISE INDICATED.

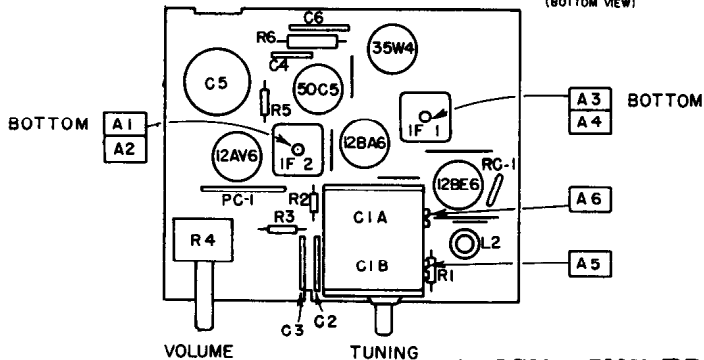
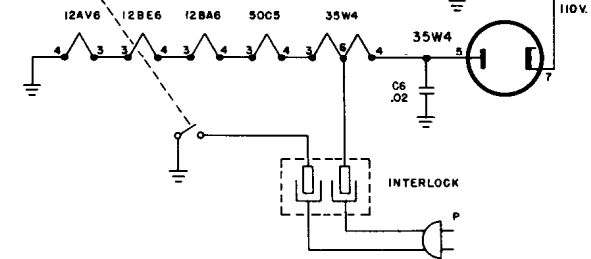

APPROXIMATE SENSITIVITIES

CIRCUIT POINT	DUMMY TO GENERATOR	INPUT FOR .05 WATT OUTPUT (0.4 VOLTS ACROSS MC)	INPUT FOR .5 WATT OUTPUT (1.26 VOLTS ACROSS MC)
1	.05 μF AT 455 KC	2000 μV	5000 μV
2	.05 μF AT 455 KC	60	150
3	STANDARD LOOP AT 1000 KC	200 μV / M	500 μV / M

ALIGNMENT PROCEDURE

PRELIMINARY:

- Output meter connection..... Across speaker voice coil
- Output meter reading to indicate 500 milliwatts (standard output)... 1.26 volts
- Connection of generator ground lead..... Floating ground
- Generator modulation..... 30% 400 cycles
- Position of Volume Control..... Fully clockwise

Position of Variable	Frequency of Generator	Dummy Antenna	Generator Output Connection	Trimmers Adjusted in Order Shown for Maximum Output	Function of Trimmer
Open	455 Kc	.05 μ fd	Pin 7 12BE6	A1, A2, A3, A4	I. F.
Open	1670 Kc		* Test Loop	A5	Oscillator
1400	1400 Kc		* Test Loop	A6	Antenna
1000	1000 Kc		* Test Loop	Fan C1A Plates	
600	600 Kc		* Test Loop	Fan C1A Plates	

* Standard Hazeltine Test Loop Model 1150 or 3 turns of wire about 6" in diameter placed about one foot from the set loop.
 The alignment procedure should be repeated in the original order for greatest accuracy. Always keep the output from the signal generator at its lowest possible value to make the AVC action of the receiver ineffective.

ARVIN MODELS 10R32 10R38 10R39 CHASSIS 1.49801

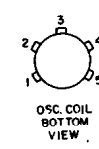
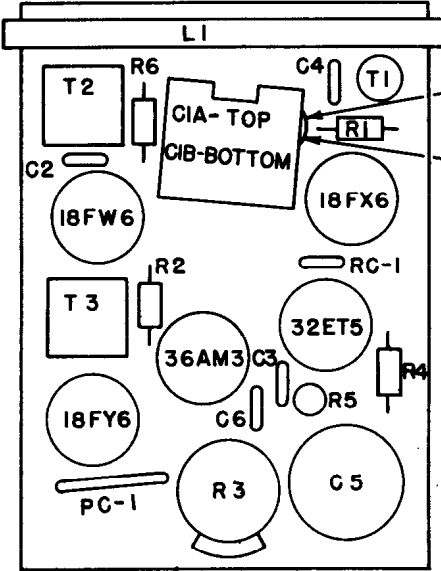
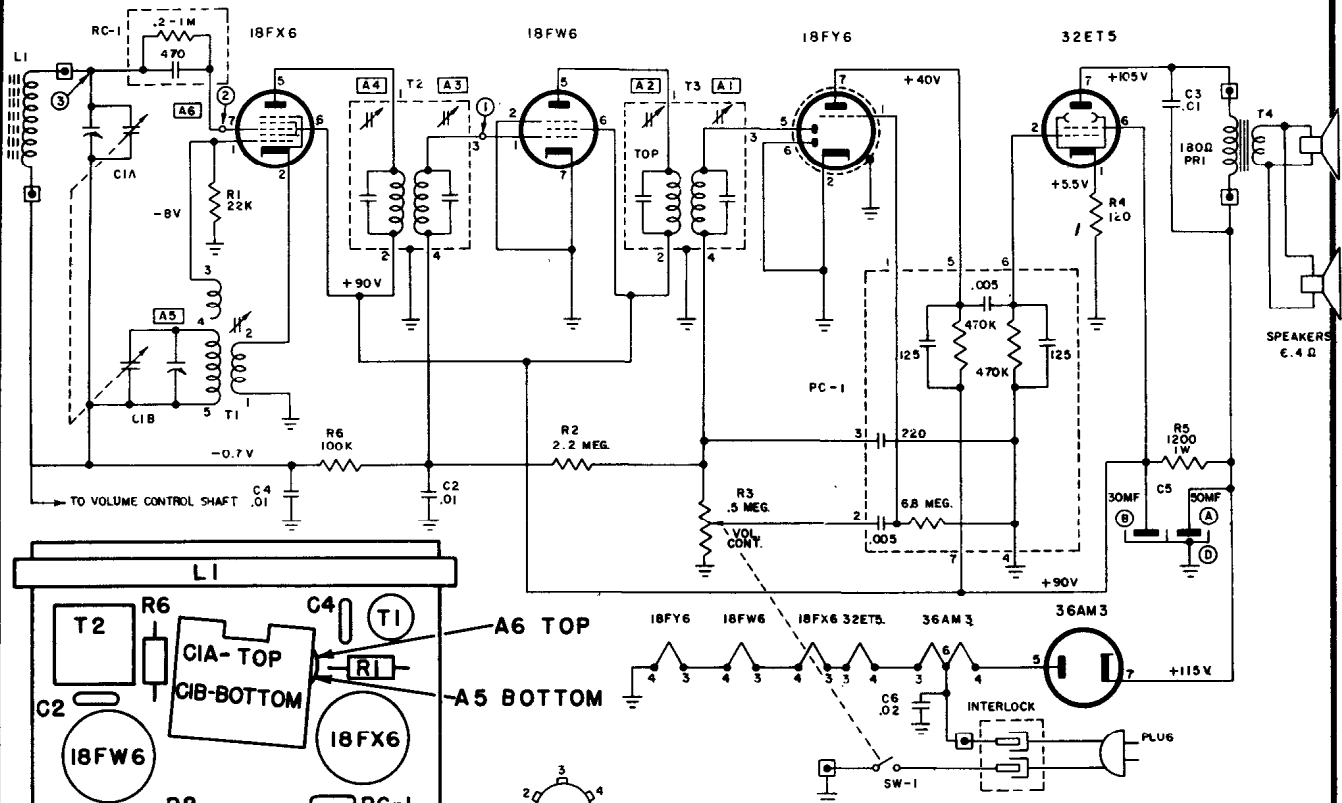

⊕ + B-
 ⊞ = EXTERNAL CONNECTIONS TO PRINTED BOARD.
 VOLTAGES MEASURED WITH A V.T.V.M.
 RESISTANCE VALUES ARE IN OHMS K-1,000, MEG-1,000,000.
 CAPACITANCE VALUES LESS THAN (1) ARE IN MICROFARADS (μf),
 AND VALUES OF (1) OR GREATER ARE IN MICROMICROFARADS (μμf), UNLESS OTHERWISE INDICATED.

ALIGNMENT PROCEDURE

Output meter connection ... Across speaker voice coil
 Connection of generator ground lead .. Floating ground
 Generator modulation 30% 400 cycles
 Position of Volume Control..... Fully clockwise

Position of Variable	Frequency of Generator	Dummy Antenna	Generator Output Connection	Trimmers Adjusted in Order Shown for Maximum Output	Function of Trimmer
Open	455 Kc	.05 μ fd	Pin 7 18FX6	A1, A2, A3, A4	I. F. Oscillator Antenna
Open	1670 Kc		* Test Loop	A5	
1400	1400 Kc		* Test Loop	A6	
1000	1000 Kc		* Test Loop	Fan C1A Plates	
600	600 Kc		* Test Loop	Fan C1A Plates	

* Standard Hazeltine Test Loop Model 1150 or 3 turns of wire about 6" in diameter placed about one foot from the set loop.
 The alignment procedure should be repeated in the original order for greatest accuracy. Always keep the output from the signal generator at its lowest possible value to make the AVC action of the receiver ineffective.

ARVIN

MODELS 30R12 30R18

CODE 1. 48101
CODE 1. 48102

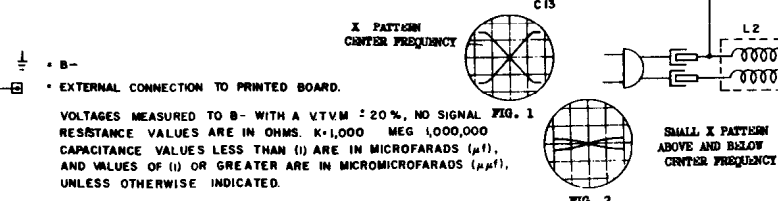
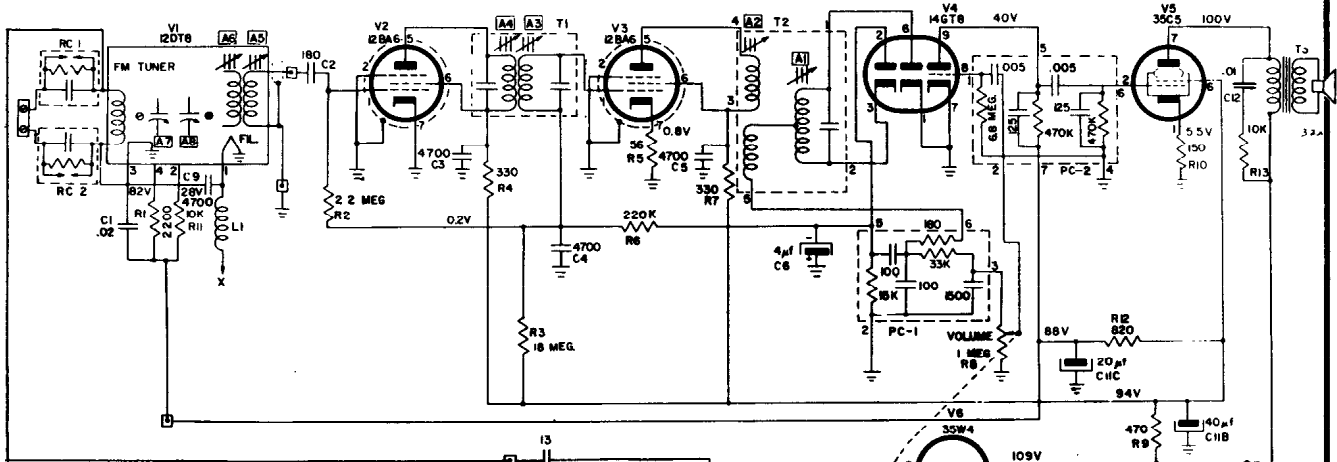

ALIGNMENT PROCEDURE

Detector and I. F. alignment using signal Generator and Oscilloscope.

1. Connect FM Generator, High Side, to grid (pin 1) of 12BA6 2nd I. F. tube through .01 mfd. dummy.
2. Set generator frequency to 10.7 Mc. modulated either 60 cycles or 400 cycles, 480 Kc sweep (240 Kc deviation)
3. Connect vertical input of scope across volume control of receiver (grounded terminal to B-, ungrounded terminal to high side of control).
4. Set scope switch for internal synchronization and set horizontal oscillator to 2X frequency of modulating voltage of generator. (120 or 800 cycles)
5. Tune FM to high end of band.
6. Adjust frequency vernier of horizontal oscillator on scope until the pattern becomes stationary.
7. Adjust ratio detector primary slug No. A2 (outer peak) for maximum vertical sweep of the scope pattern.
8. Adjust ratio detector secondary slug No. A1 (outer peak) to center the cross-over point of the pattern. Pattern should look like Figure 1, with the same amount of curve on both ends, and the cross-over point in the center.
9. Adjust I. F. slugs A3, A4 (outer peak) for greatest vertical sweep of the pattern, consistent with linearity. If the I. F. slugs are adjusted for maximum sweep of the pattern, the pattern may become non-linear. Therefore, adjustment should be made for the greatest sweep which can be obtained and still have all four ends of the "X" pattern similar in size and shape.
10. Connect generator to antenna screws on the back of the chassis.
11. Adjust tuner slugs A5, A6 for greatest vertical sweep consistent with linearity.
12. Check the alignment of the I. F. and detector circuits by varying the signal generator frequency above and below the center frequency of 10.7 Mc. If the receiver is perfectly aligned, two small "x" patterns of similar size and shape will result, one on either side of the center frequency. See Figure 2.

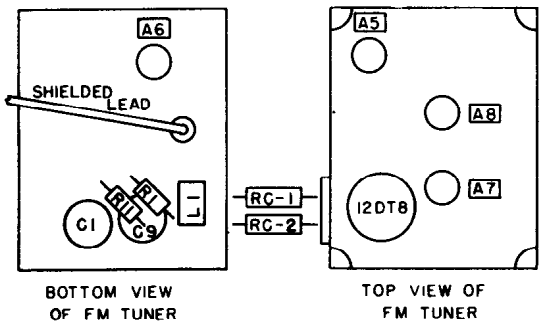

BOTTOM VIEW OF FM TUNER

TOP VIEW OF FM TUNER

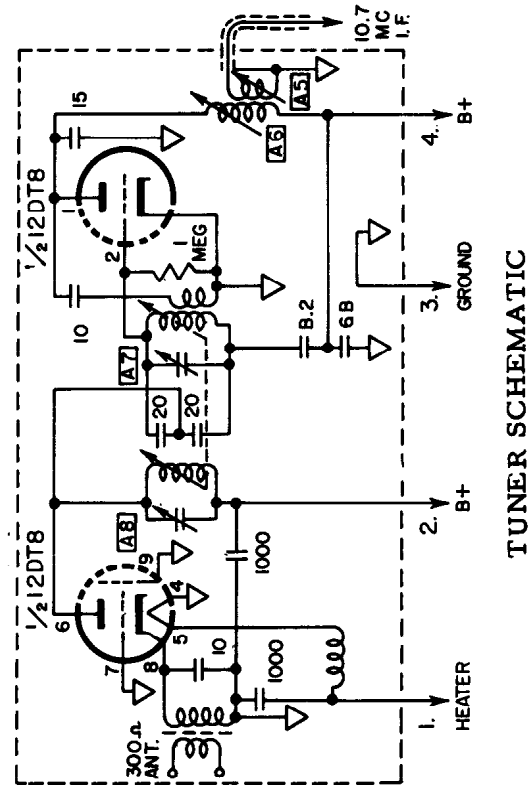

TUNER SCHEMATIC

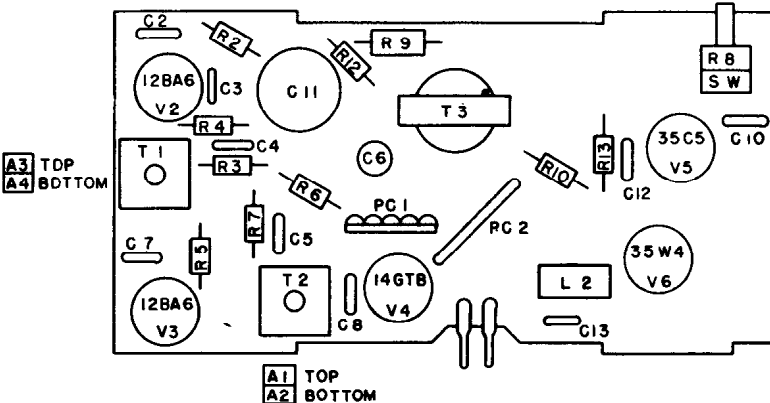

ARVIN RADIO MODELS 50R65 50R67 CODE 1.47001

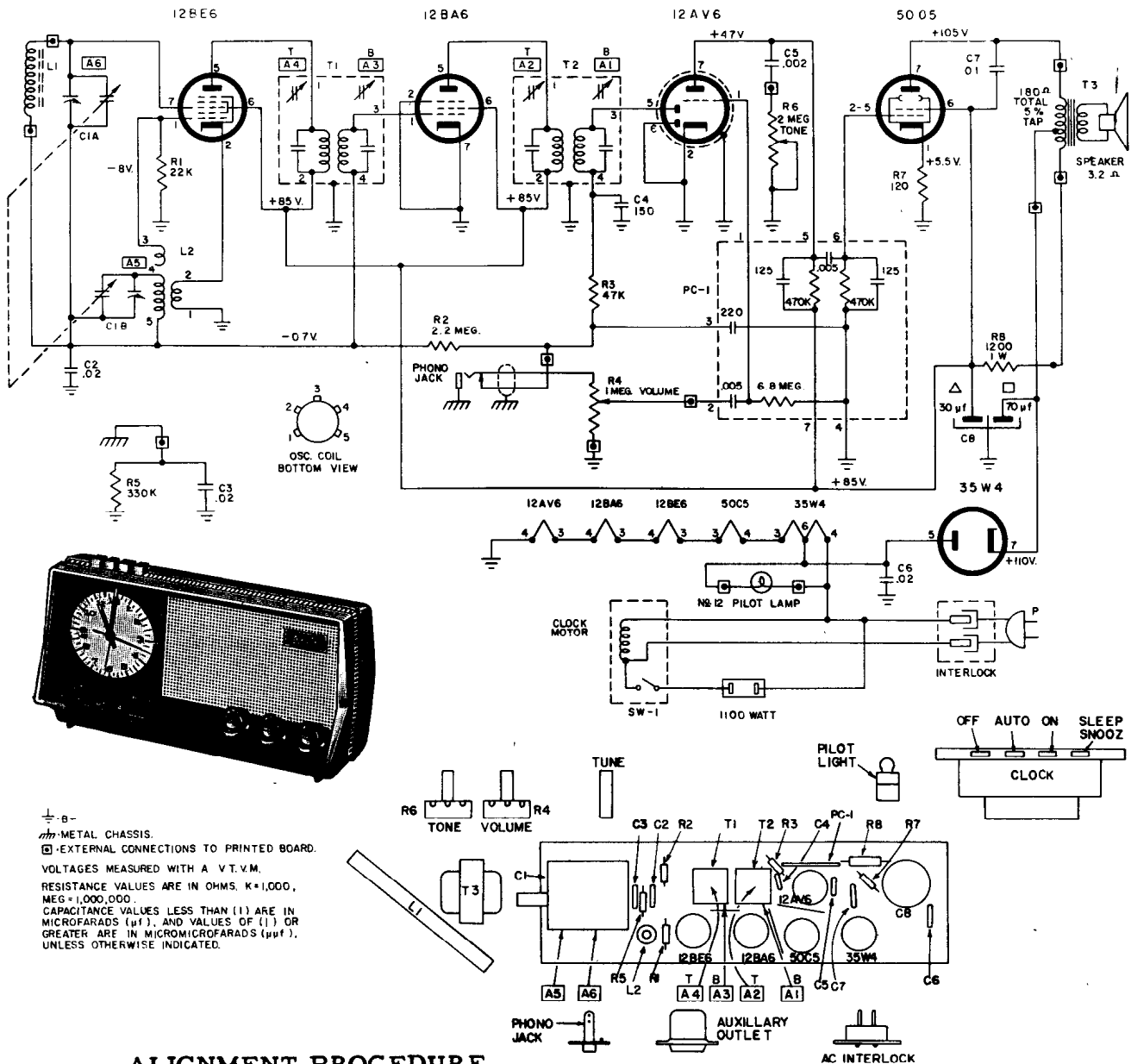

-B- METAL CHASSIS.
 □ - EXTERNAL CONNECTIONS TO PRINTED BOARD.
 VOLTAGES MEASURED WITH A V.T.V.M.
 RESISTANCE VALUES ARE IN OHMS, K=1,000,
 MEG=1,000,000.
 CAPACITANCE VALUES LESS THAN (1) ARE IN
 MICROFARADS (μf), AND VALUES OF (1) OR
 GREATER ARE IN MICROMICROFARADS (μμf),
 UNLESS OTHERWISE INDICATED.

ALIGNMENT PROCEDURE

Position of Variable	Frequency of Generator	Dummy Antenna	Generator Output Connection	Trimmers Adjusted in Order Shown for Maximum Output	Functions of Trimmer
Open	455	.05 μf	Pin 7 12BE6	A1, A2, A3, A4	I. F.
Open	1670		* Test Loop	A5	Oscillator
1400	1400		* Test Loop	A6	Antenna
600	600		* Test Loop	Check Point	

* Standard Hazeltine Test Loop Model 1150 or 3 turns of wire about 6" in diameter placed about one foot from the set loop.
 The alignment procedure should be repeated in the original order for greatest accuracy. Always keep the output from the signal generator at its lowest possible value to make the AVC action of the receiver ineffective.

Arvin MODELS 60R23 60R28 60R29 CHASSIS 1.49201

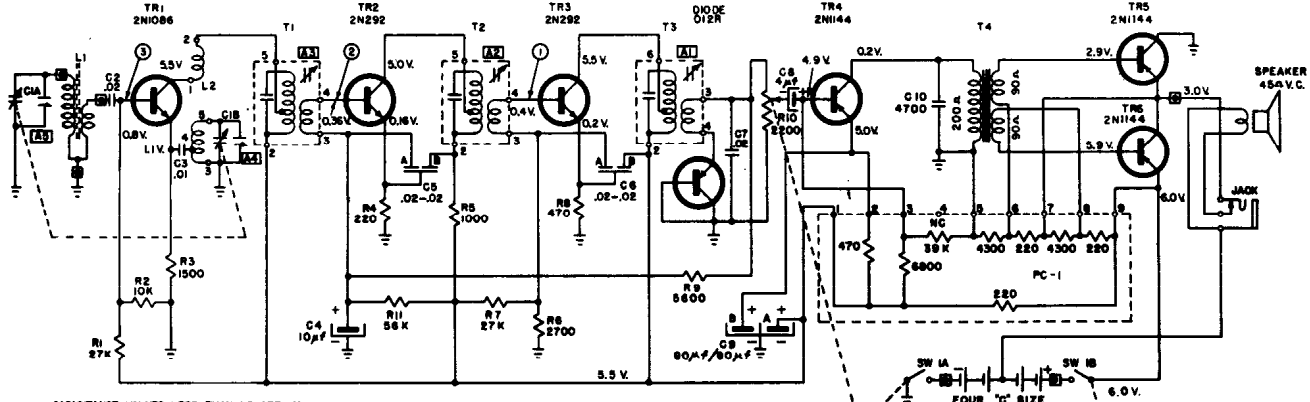

CAPACITANCE VALUES LESS THAN 1.0 ARE IN MICROFARADS (μF), AND VALUES GREATER THAN 1.0 ARE IN MICRO-MICROFARADS ($\mu\mu\text{F}$) EXCEPT WHERE NOTED.

VOLTAGE READINGS TO COMMON GROUND ARE MEASURED WITH VACUUM TUBE VOLTMETER UNDER NO SIGNAL CONDITIONS WITH TUNING CAPACITOR CLOSED AND VOLUME CONTROL AT MAXIMUM CLOCKWISE ROTATION.

RESISTANCE VALUES ARE IN OHMS, K=1000.

+ COMMON GROUND SYMBOL.

⊕ EXTERNAL CONNECTION TO PRINTED CIRCUIT.

TOTAL BATTERY CURRENT DRAIN UNDER NO SIGNAL CONDITIONS, 5 TO 8 MA.

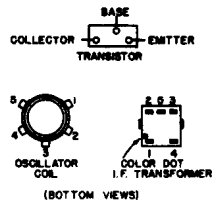

I. F. 455 KC.

SIGNAL TEST POINTS	TEST FREQUENCY	SERIES CAPACITOR TO GENERATOR (ATV ACROSS 48- μ)	INPUT FOR 80W OUTPUT (ATV ACROSS 48- μ)
①	455 KC	.05 μF	2000 μV
②	455 KC	.05 μF	110 μV
③	455 KC	.05 μF	4 μV
④	1000 KC	STANDARD LOOP	300 μV M

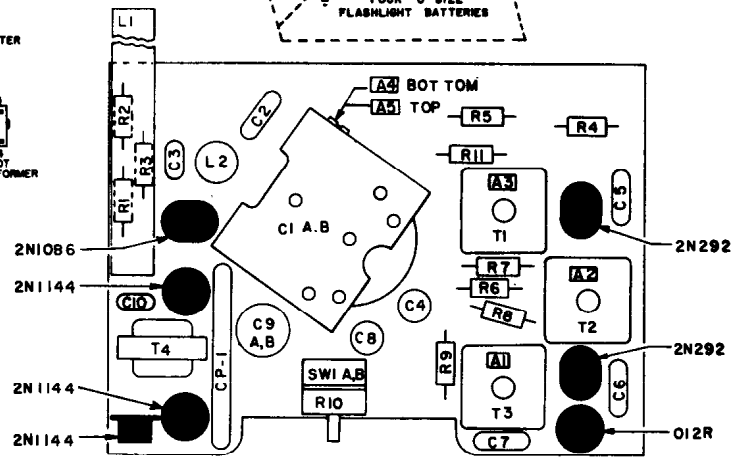

Arvin MODELS 60R47 & 60R49 CHASSIS 1.50401

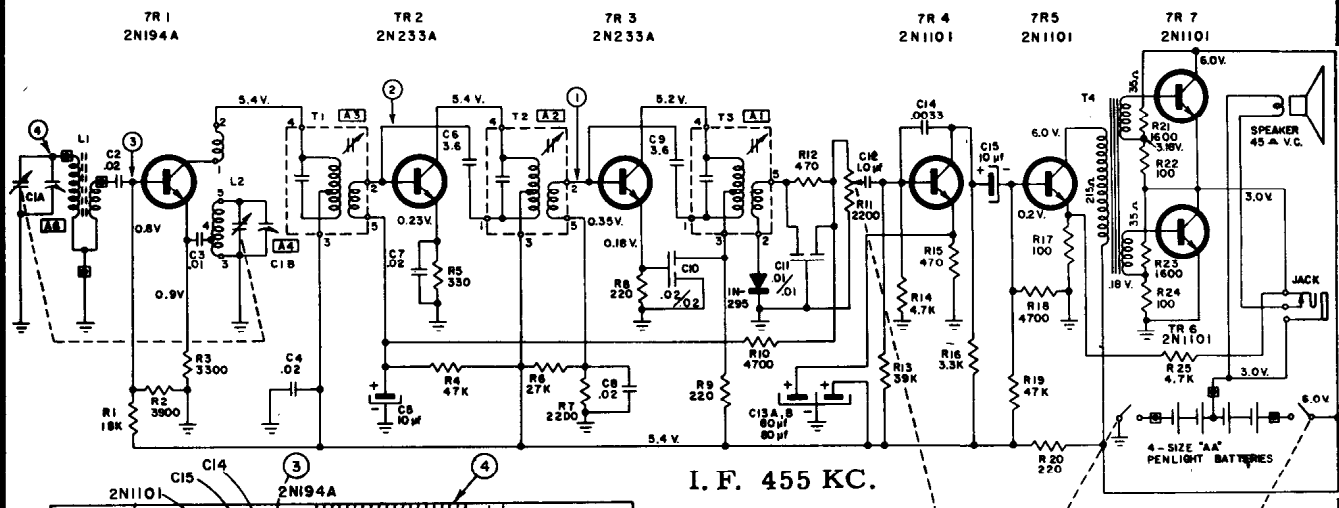

I. F. 455 KC.

CAPACITANCE VALUES LESS THAN 1.0 ARE IN MICROFARADS (μF) AND VALUES GREATER THAN 1.0 ARE IN MICRO-MICROFARADS ($\mu\mu\text{F}$) EXCEPT WHERE NOTED.

VOLTAGE READINGS TO COMMON GROUND ARE MEASURED WITH VACUUM TUBE VOLTMETER UNDER NO SIGNAL CONDITIONS WITH TUNING CAPACITOR CLOSED AND VOLUME CONTROL AT MAXIMUM CLOCKWISE ROTATION.

RESISTANCE VALUES ARE IN OHMS, K=1000.

+ COMMON GROUND SYMBOL.

⊕ EXTERNAL CONNECTION TO PRINTED CIRCUIT.

TOTAL BATTERY CURRENT DRAIN UNDER NO SIGNAL CONDITIONS, 7 TO 11 MA.

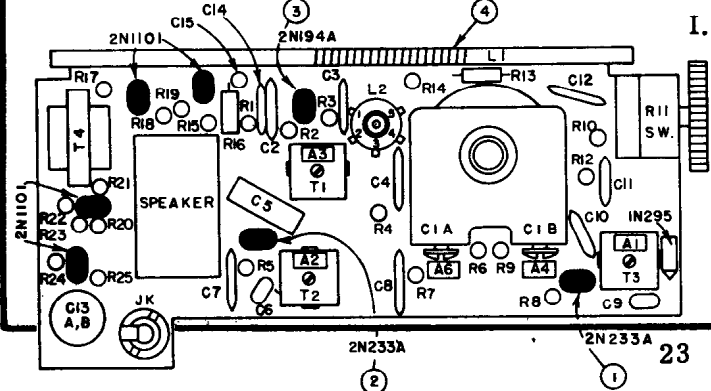
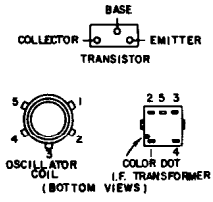

Arvin MODEL 60R58 CHASSIS 1.50300

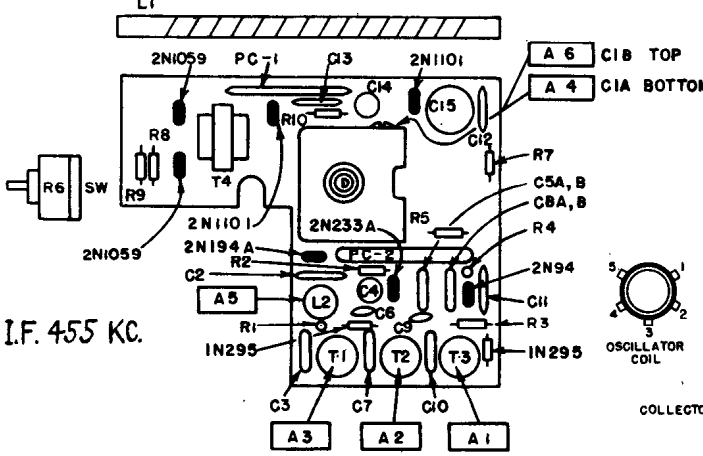
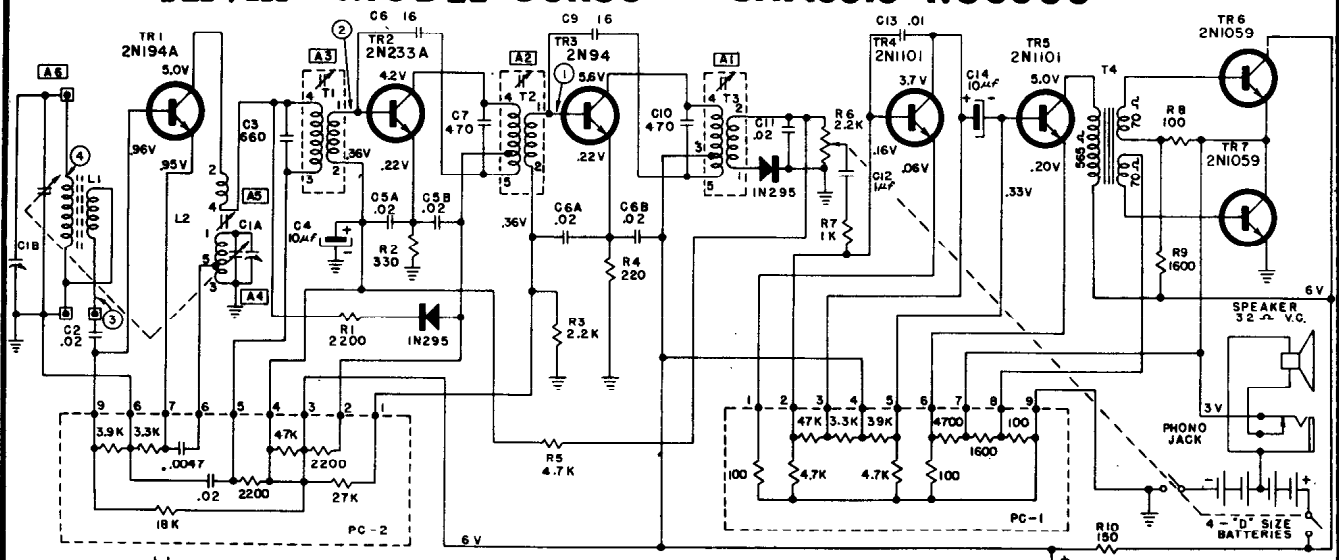

RESISTANCE VALUES ARE IN OHMS; K=1000.
 CAPACITANCE VALUES LESS THAN 10 ARE IN MICROFARADS (μf), & VALUES GREATER THAN 10 ARE IN MICRO-MICROFARADS ($\mu\mu f$) EXCEPT WHERE NOTED.
 VOLTAGE READINGS TO COMMON GROUND ARE MEASURED WITH VACUUM TUBE VOLTMETER UNDER NO SIGNAL CONDITIONS WITH TUNING CAPACITOR CLOSED & VOLUME CONTROL AT MAXIMUM CLOCKWISE ROTATION.
 ⊕ - COMMON GROUND SYMBOL.
 □ - EXTERNAL CONNECTION TO PRINTED CIRCUIT.

SIGNAL TEST POINT	TEST FREQUENCY	SERIES CAPACITOR TO GENERATOR	INPUT FOR 50 M W OUTPUT TO GENERATOR (1.26 V ACROSS 32 Ω)
1	455 KC	.05 μf	900 μV
2	455 KC	.05 μf	30 μV
3	455 KC	.05 μf	5 μV
4	1000 KC	STANDARD LOOP	200 $\mu V/M$

I.F. 455 KC.

ARVIN MODELS 60R63 & 60R69 CHASSIS 1.50101 60R73 & 60R79

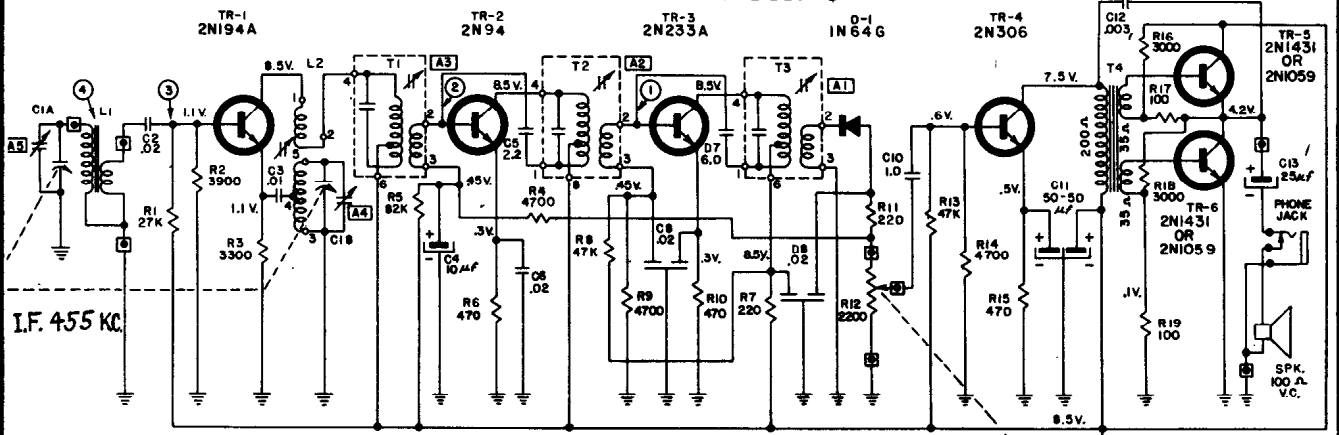

CAPACITANCE VALUES LESS THAN 1.0 ARE IN MICROFARADS (μf), AND VALUES GREATER THAN 1.0 ARE IN MICRO-MICROFARADS ($\mu\mu f$) EXCEPT WHERE NOTED.
 VOLTAGE READINGS TO COMMON GROUND ARE MEASURED WITH VACUUM TUBE VOLTMETER UNDER NO SIGNAL CONDITIONS WITH TUNING CAPACITOR CLOSED & VOLUME CONTROL AT MAXIMUM CLOCKWISE ROTATION.
 RESISTANCE VALUES ARE IN OHMS; K=1000.
 ⊕ - COMMON GROUND SYMBOL.

SIGNAL TEST POINT	TEST FREQUENCY	SERIES CAPACITOR TO GENERATOR	INPUT FOR 50 M W OUTPUT TO GENERATOR (1.7 V ACROSS 100 Ω)
①	455 KC	.05 μf	500 μV
②	455 KC	.05 μf	50 μV
③	455 KC	.05 μf	2 μV
④	1000 KC	STANDARD LOOP	200 $\mu V/M$

⊕ - EXTERNAL CONNECTION TO PRINTED CIRCUIT
 TOTAL BATTERY CURRENT DRAIN UNDER NO SIGNAL CONDITIONS, 5.5 TO 7 MA.
 BASE
 COLLECTOR
 EMITTER
 RADIO BATTERY NEDA #1804
 OSCILLATOR COIL
 COLOR DOT
 I.F. TRANSFORMER (BOTTOM VIEWS)

ARVIN PHONOGRAPH

MODEL 90P53

MODEL 90P58

CODE 1.49501

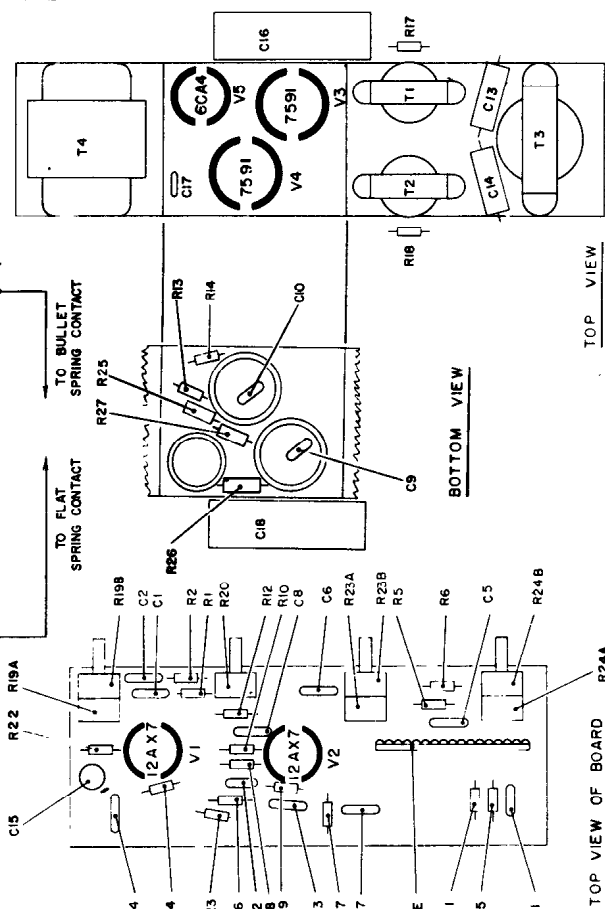
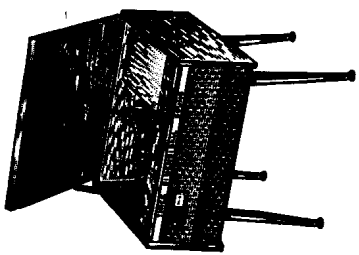
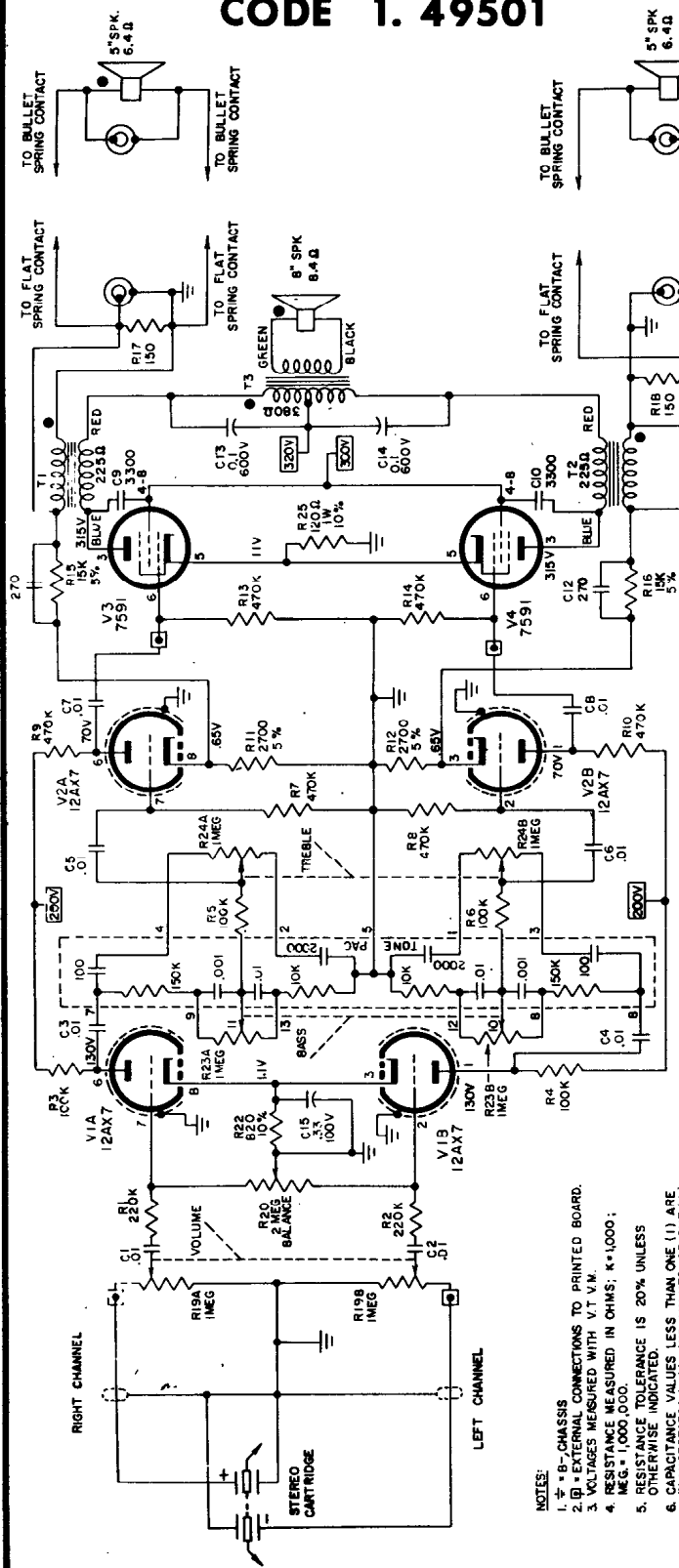

- NOTES:
1. ∇ - B-CHASSIS
 2. \square - EXTERNAL CONNECTIONS TO PRINTED BOARD.
 3. VOLTAGES MEASURED WITH V.T.V.M.
 4. RESISTANCE MEASURED IN OHMS; *1,000; MEG. = 1,000,000.
 5. RESISTANCE TOLERANCE IS 20% UNLESS OTHERWISE INDICATED.
 6. CAPACITANCE VALUES LESS THAN ONE (1) ARE IN MICROFARADS (μ), AND VALUES OF ONE (1) OR GREATER ARE IN MICRO-MICROFARADS ($\mu\mu$) UNLESS OTHERWISE INDICATED.
 7. COMPONENTS IN THIS AMPLIFIER ARE INTERCONNECTED TO RESULT IN A CONSISTANT PHASE RELATION BETWEEN APPLIED VOLTAGE AND VOICE COIL MOVEMENT (IE A POSITIVE INPUT VOLTAGE MOVES VOICE COIL OUTWARD IN RIGHT CHANNEL, INWARD ON LEFT CHANNEL). DO NOT DISTURB THIS PHASE RELATIONSHIP DURING SERVICING
 8. PHASING DOT.
TRANSFORMERS T1, T2 (IN PHASE WITH RED LEAD); T3 (IN PHASE WITH GREEN LEAD); SPEAKERS (POSITIVE VOLTAGE MOVES VOICE COIL OUTWARD).

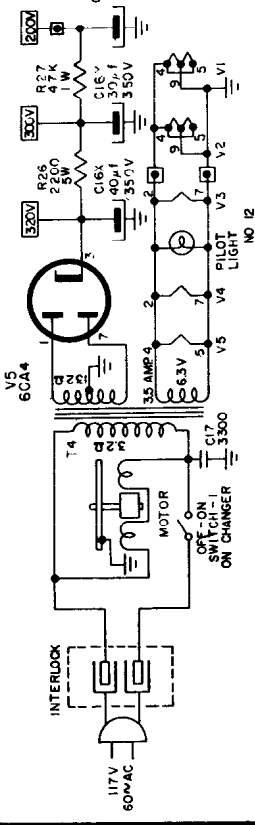

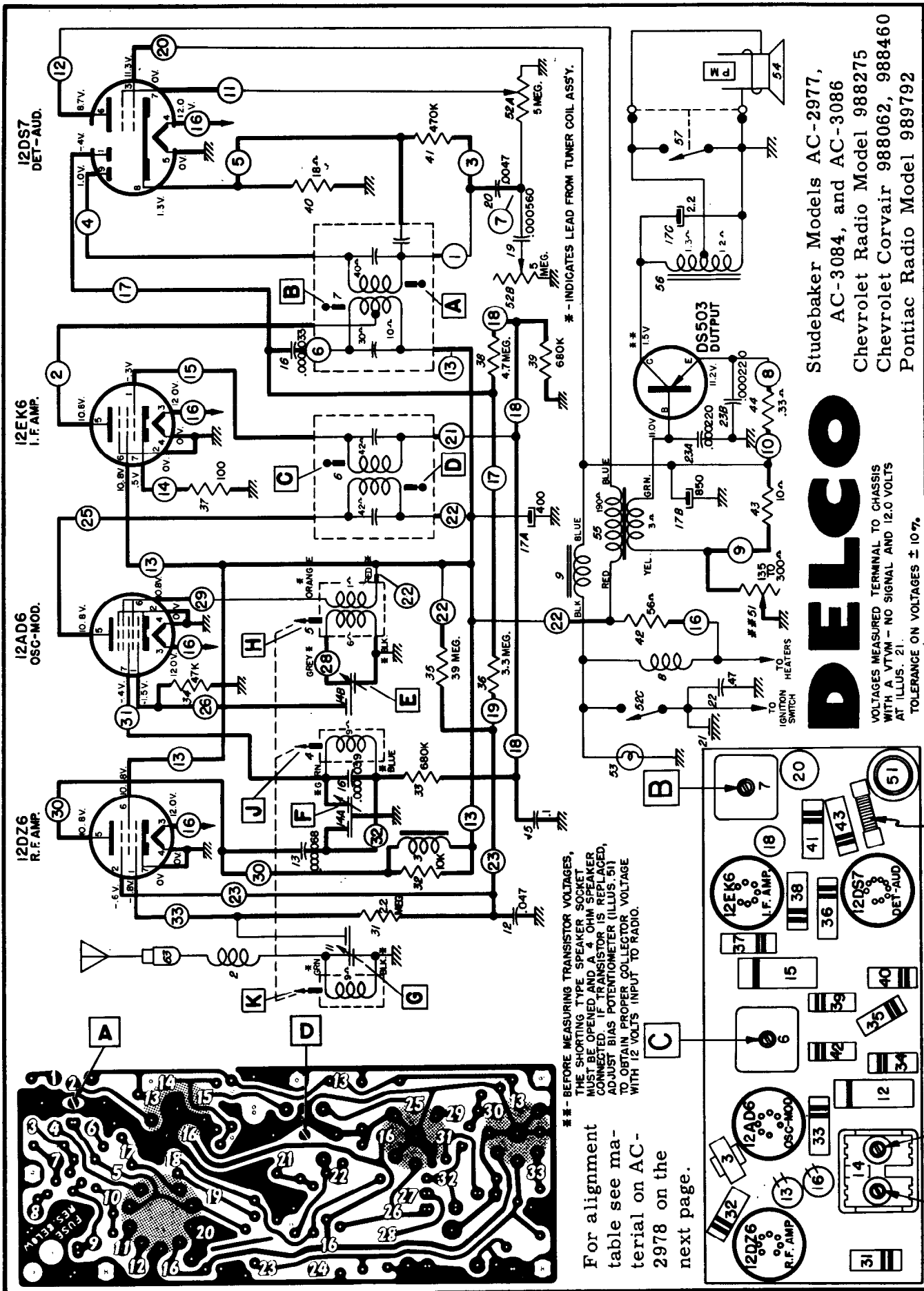

BOTTOM VIEW

Studebaker Models AC-2977,
 AC-3084, and AC-3086
 Chevrolet Radio Model 988275
 Chevrolet Corvair 988062, 988460
 Pontiac Radio Model 989792

DELCO

VOLTAGES MEASURED TERMINAL TO CHASSIS
 WITH A VTVM - NO SIGNAL AND 12.0 VOLTS
 AT ILLUS. 21.
 TOLERANCE ON VOLTAGES ± 10 %

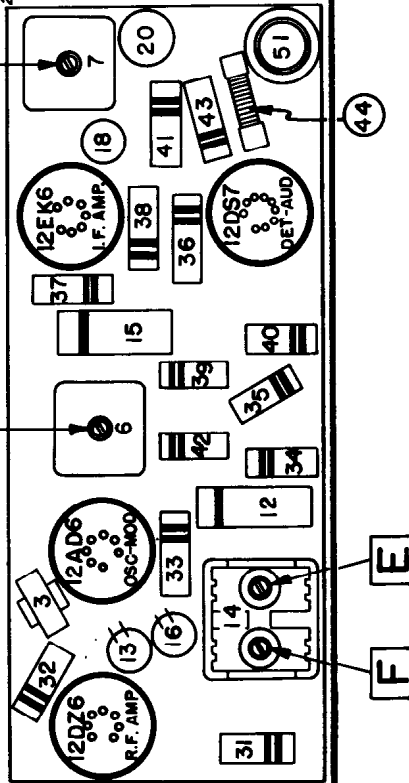

VOLUME R-21, MOST-OFTEN-NEEDED 1961 RADIO SERVICING INFORMATION

DELCO Studebaker Radio Models AC-2978, AC-3085, AC-3087

STEPS	SERIES CAPACITOR OR DUMMY ANTENNA	CONNECT SIGNAL GENERATOR TO	SIGNAL GENERATOR FREQUENCY	TUNE RECEIVER TO	ADJUST IN SEQUENCE FOR MAX. OUTPUT
1	0.1 Mfd.	12AD6 Grid (Pin #7)	262 KC.	High Frequency Stop	A, B, D, C,
2	0.000068 Mfd.	Antenna Connector	1615 KC.	High Frequency Stop	*E, F, G
3	0.000068 Mfd.	Antenna Connector	600 KC.	Signal Generator Signal	J, K
4	0.000068 Mfd.	Antenna Connector	1615 KC.	High Frequency Stop	F, G

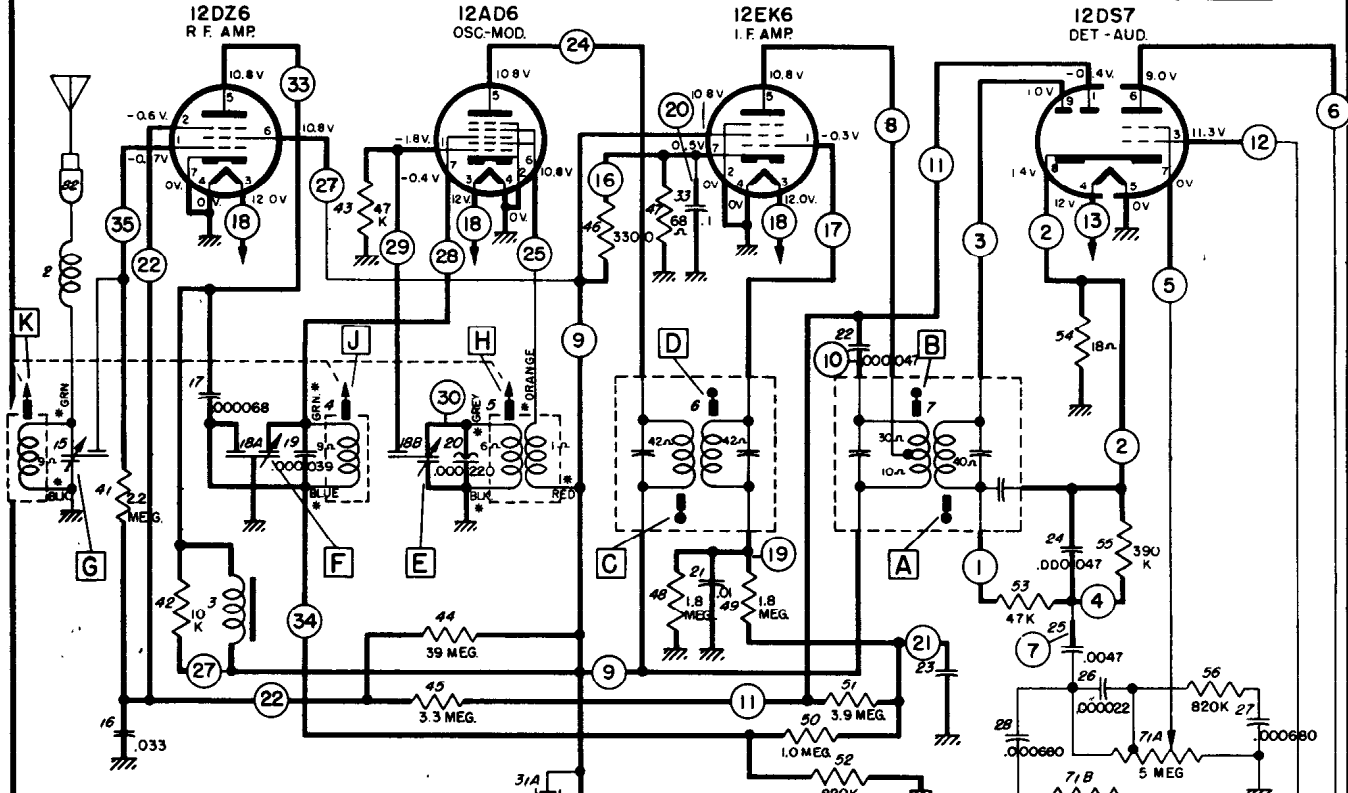
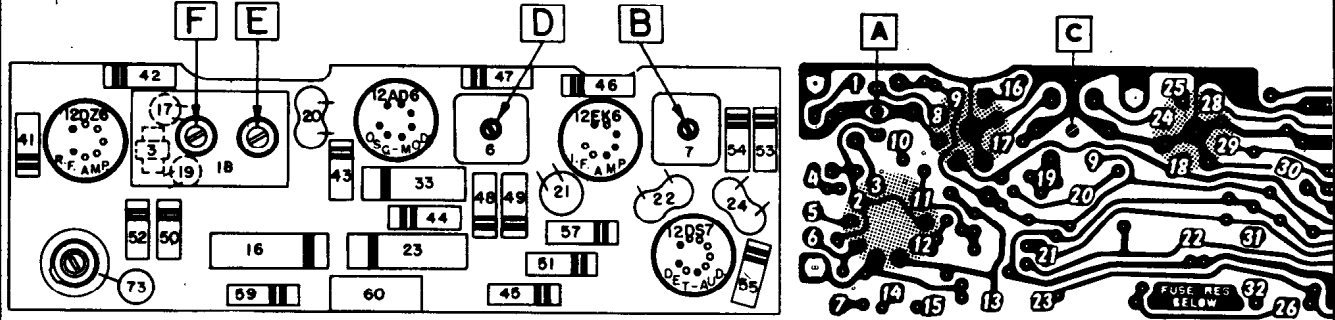

VOLTAGES MEASURED TERMINAL TO CHASSIS WITH A VTVM - NO SIGNAL AND 12.0 VOLTS AT ILLUS. 29.

OSCILLATOR GRID VOLTAGE TAKEN WITH SET TUNED TO 1000 KC. TOTAL "A" DRAIN AT 12V - 2.2 AMPS. TOLERANCE ON VOLTAGES $\pm 10\%$

* - INDICATES LEAD FROM TUNER COIL ASSY.

** - BEFORE MEASURING TRANSISTOR VOLTAGES, THE SHORTING TYPE SPEAKER SOCKET MUST BE OPENED AND A 4 OHM SPEAKER CONNECTED. IF TRANSISTOR IS REPLACED, ADJUST BIAS POTENTIOMETER (ILLUS. 73) TO OBTAIN PROPER COLLECTOR VOLTAGE WITH 12 VOLTS INPUT TO RADIO.

ILLUS. 60 IS A FUSE RESISTOR FOR THE TRANSISTOR. SERVICE WITH EXACT REPLACEMENT

"A" LEAD TO HEATERS

□ OUTPUT TRANSFORMER WILL APPEAR SHORTED IF SHORTING TYPE SPEAKER SWITCH IS NOT HELD OPEN

STUDEBAKER AC-2978—PRINTED CIRCUIT SHOWN IN HEAVY LINES.

DELCO

BUICK MODEL 980051

SERVICING INFORMATION

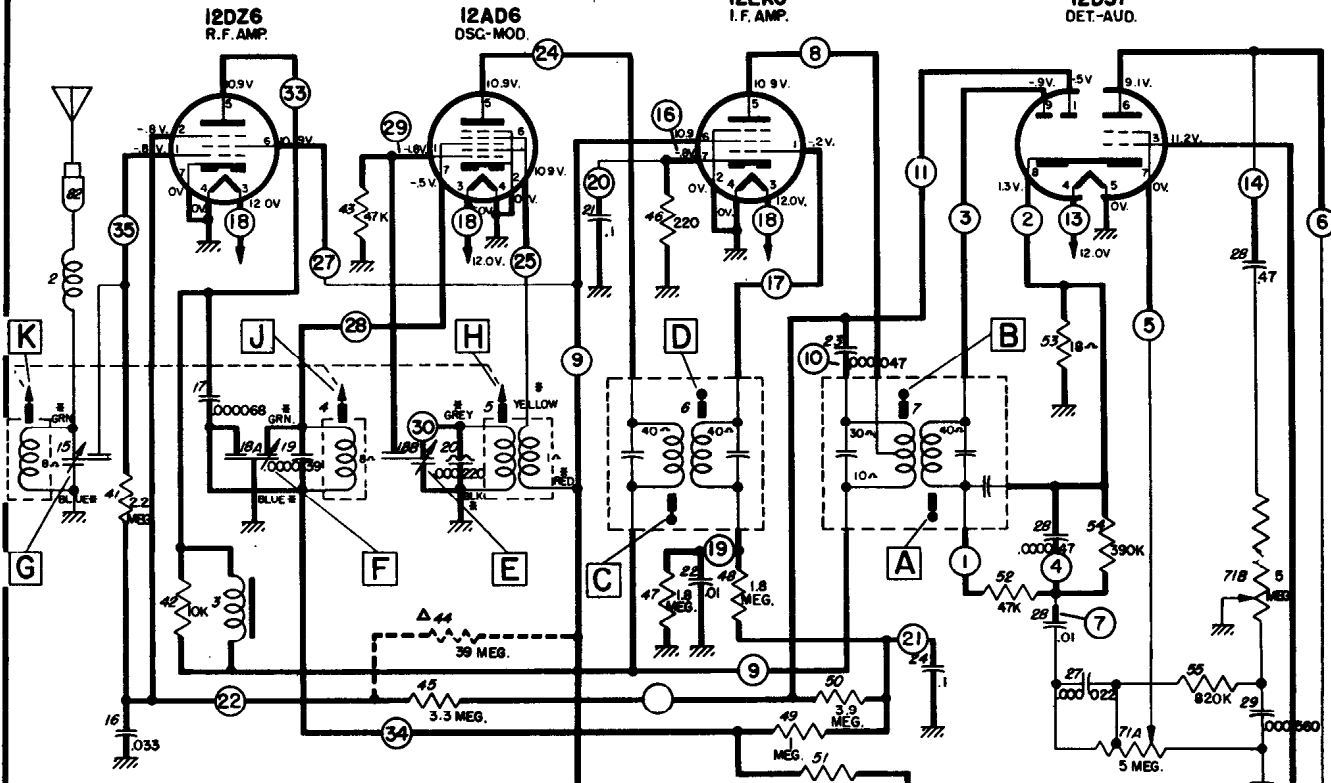
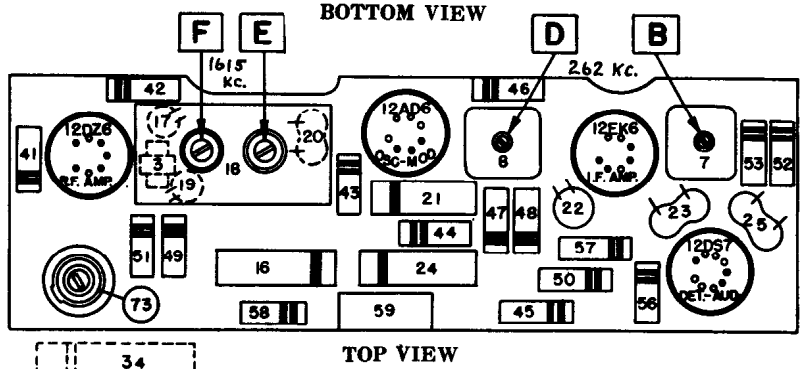
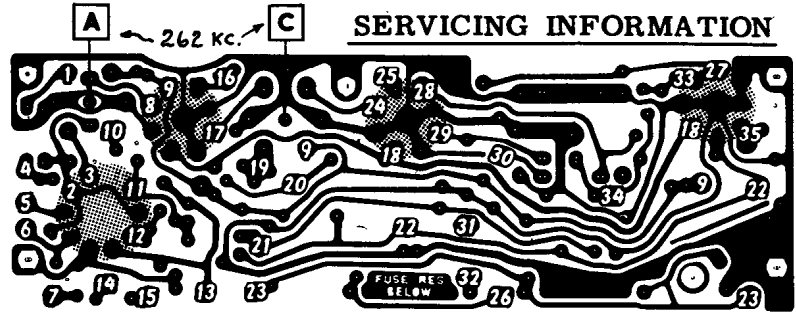
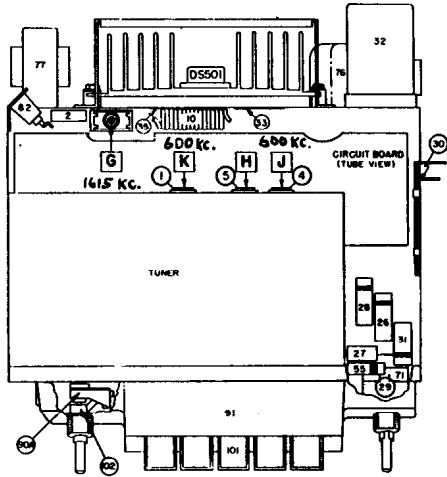

VOLTAGES MEASURED TERMINAL TO CHASSIS WITH A VTVM - NO SIGNAL AND 12.0 VOLTS AT ILLUS. 30.

OSCILLATOR GRID VOLTAGE TAKEN WITH SET TUNED TO 1000 KC.

TOTAL "A" DRAIN AT 12V. - 2.2 AMPS.

TOLERANCE ON VOLTAGES $\pm 10\%$

* - INDICATES LEAD FROM TUNER COIL ASSY.

** - BEFORE MEASURING TRANSISTOR VOLTAGES THE SHORTING TYPE SPEAKER SOCKET MUST BE OPENED AND A 4 OHM SPEAKER CONNECTED. IF TRANSISTOR IS REPLACED, ADJUST BIAS POTENTIOMETER (ILLUS. 73) TO OBTAIN PROPER COLLECTOR VOLTAGE WITH 12 VOLTS INPUT TO RADIO.

† - ILLUS 59 IS A FUSE RESISTOR FOR THE TRANSISTOR.

△ - THIS PART WILL NOT APPEAR IN ALL RADIOS.

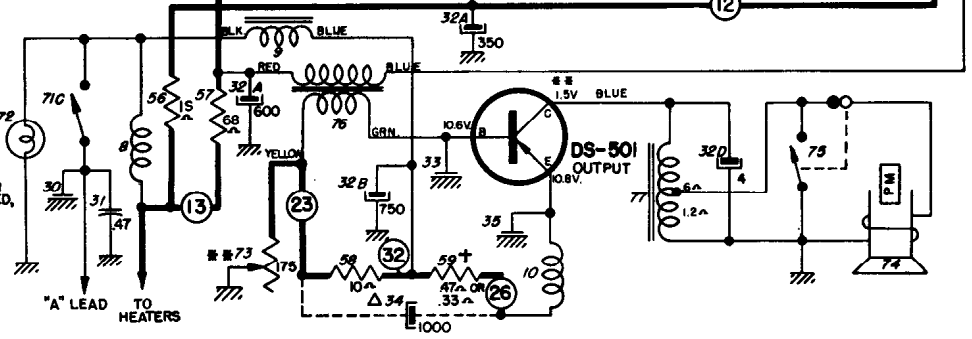

VOLUME R-21, MOST-OFTEN-NEEDED 1961 RADIO SERVICING INFORMATION

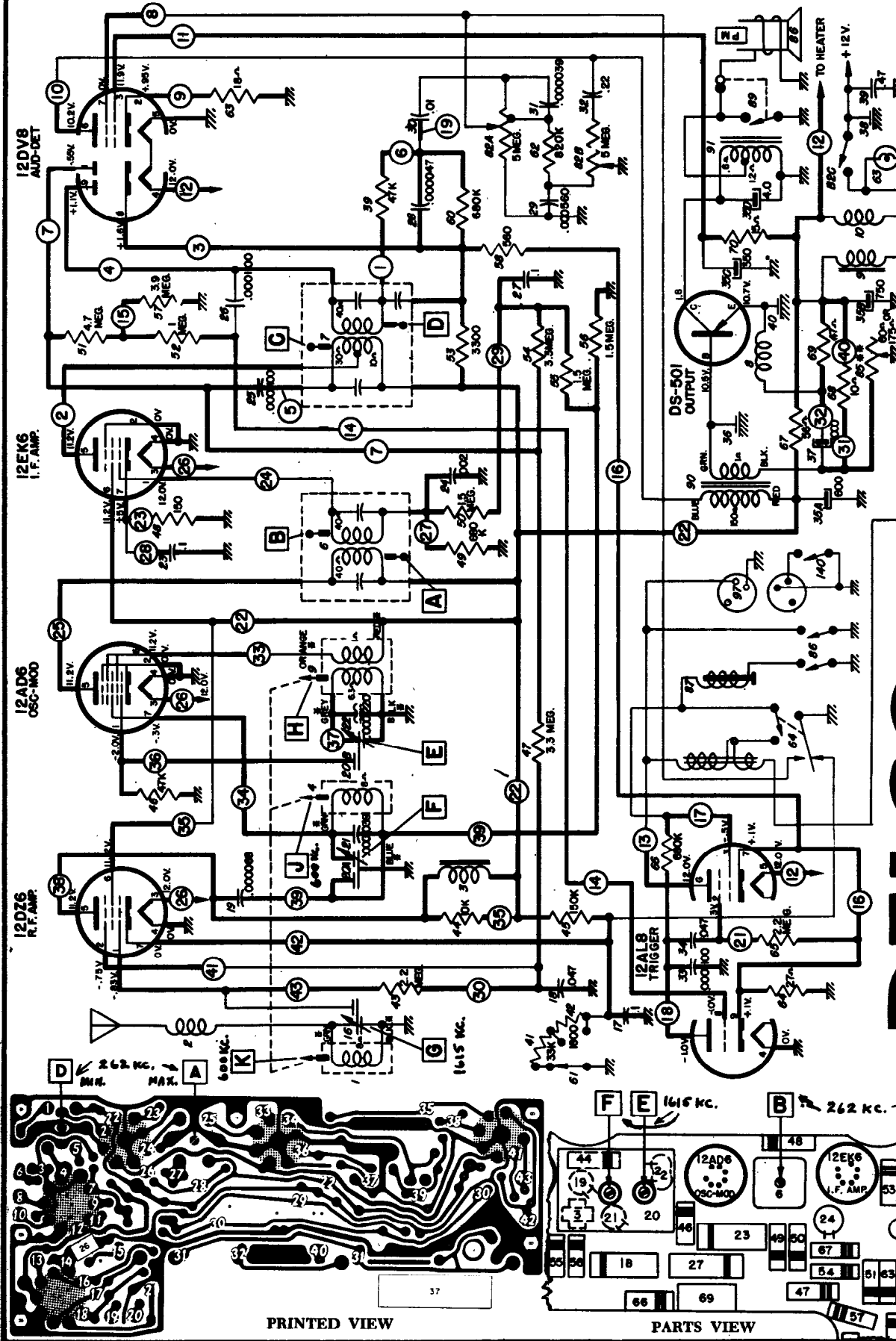

Voltages measured terminal to chassis with a VTVM - No Signal and 12.0 volts at Illustration 38.
 Oscillator grid voltage taken with set tuned to 1000 kc.
 Total "A" drain at 12 volts - 2.6 amps.
 Tolerance on voltages ± 10%.

DELCO

BUICK 980052 BUICK 980135
 PRINTED CIRCUIT SHOWN IN HEAVY LINES

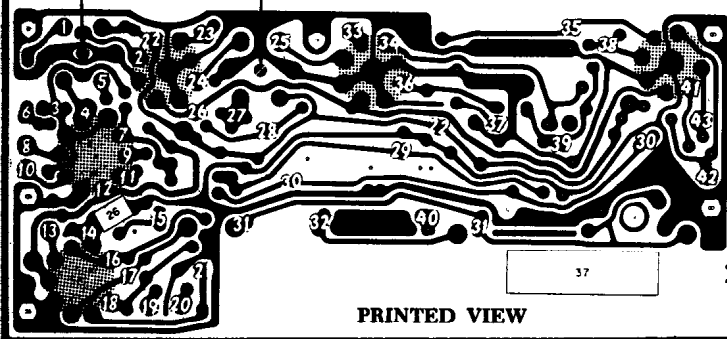

PRINTED VIEW

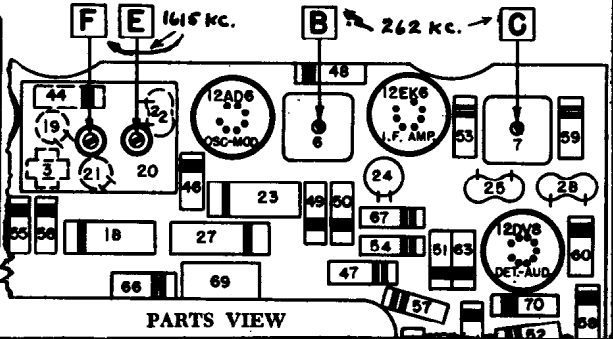

PARTS VIEW

DELCO

CHEVROLET MODEL 988276

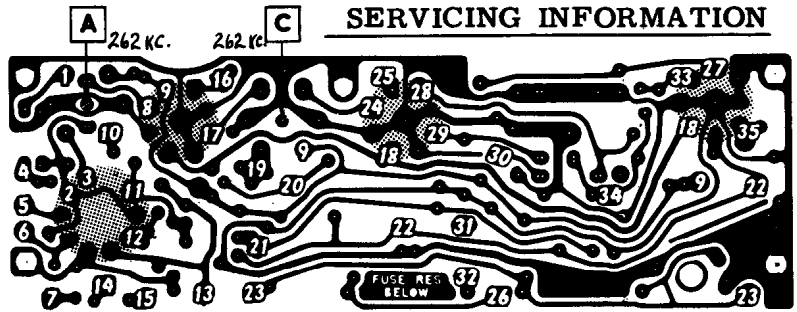
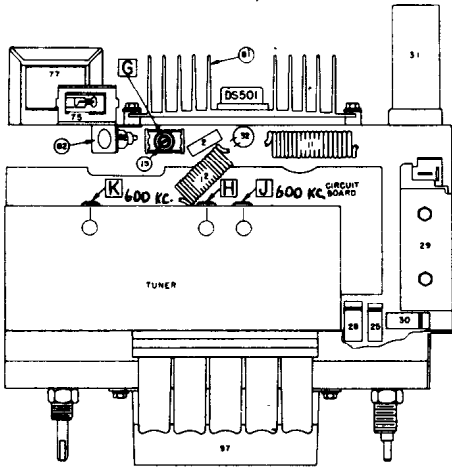

BOTTOM VIEW

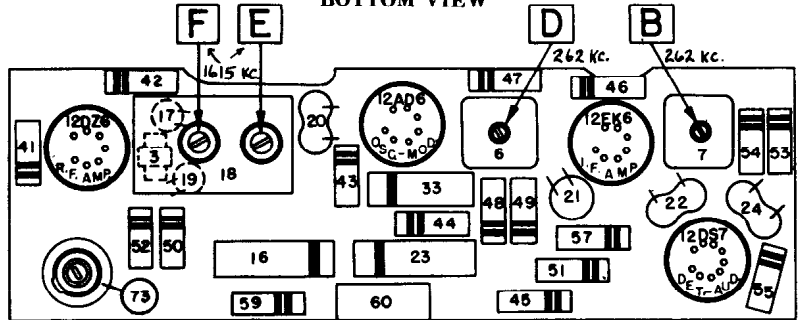

TOP VIEW

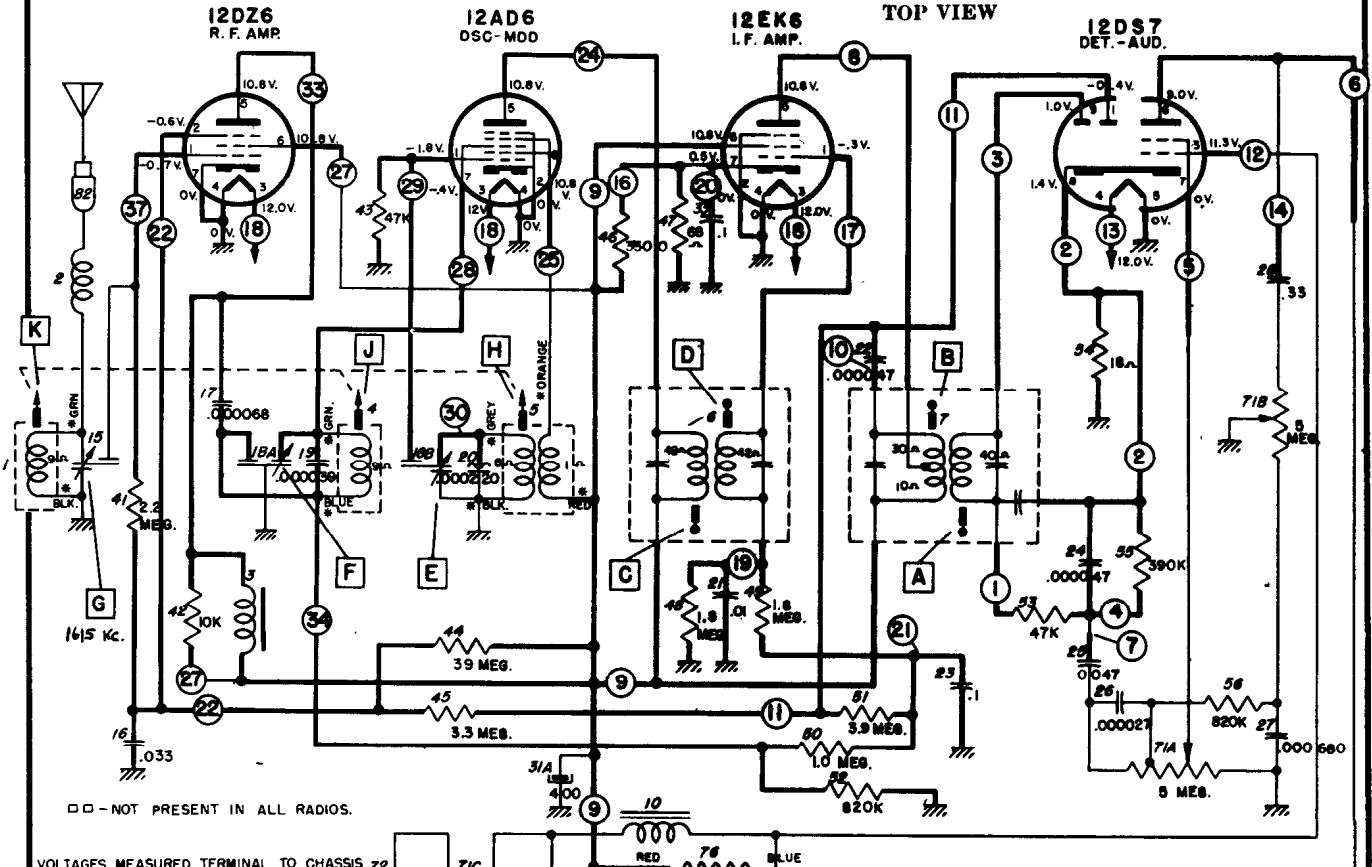

□ - NOT PRESENT IN ALL RADIOS.

VOLTAGES MEASURED TERMINAL TO CHASSIS 72 WITH A VTVM - NO SIGNAL AND 12.0 VOLTS AT ILLUS. 29.

OSCILLATOR GRID VOLTAGE TAKEN WITH SET TUNED TO 1000 KC.
TOTAL "A" DRAIN AT 12V. -2.2 AMPS.
TOLERANCE ON VOLTAGES ±10%

* - INDICATES LEAD FROM TUNER COIL ASSY.
** - BEFORE MEASURING TRANSISTOR VOLTAGES, THE SHORTING TYPE SPEAKER SOCKET MUST BE OPENED AND A 4 OHM SPEAKER CONNECTED. IF TRANSISTOR IS REPLACED, ADJUST BIAS POTENTIOMETER (ILLUS. 73) TO OBTAIN PROPER COLLECTOR VOLTAGE WITH 12 VOLTS INPUT TO RADIO

† - ILLUS. 60 IS A FUSE RESISTOR FOR THE TRANSISTOR. SERVICE WITH EXACT REPLACEMENT.

□ - OUTPUT TRANSFORMER WILL APPEAR SHORTED IF SHORTING TYPE SPEAKER SWITCH IS NOT HELD OPEN.

CHEVROLET 988276—PRINTED CIRCUIT SHOWN IN HEAVY LINES.

DELCO

BUICK MODEL 980132
 OLDSMOBILE MODEL 989387

Alignment in Table 3, Page 38

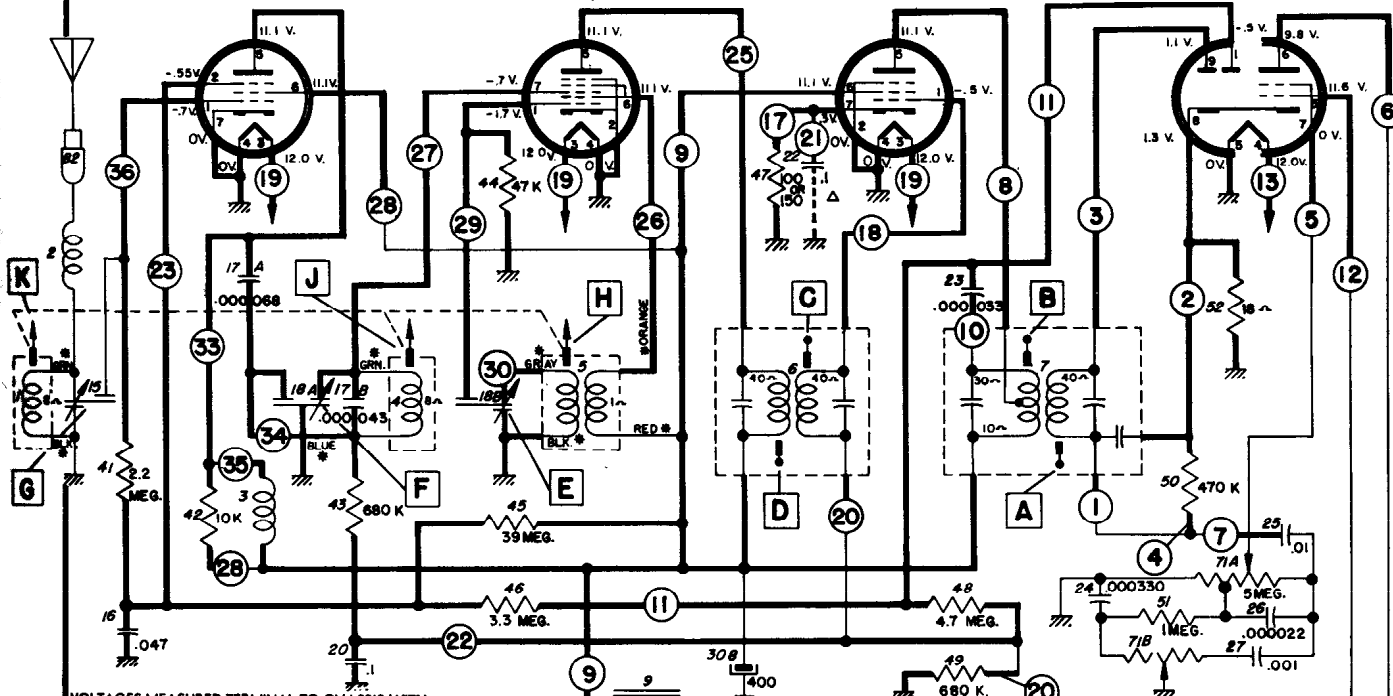
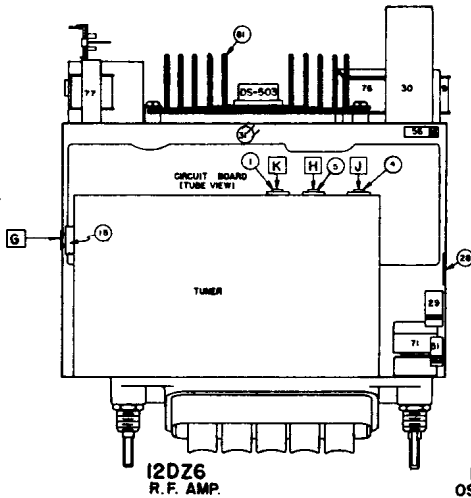
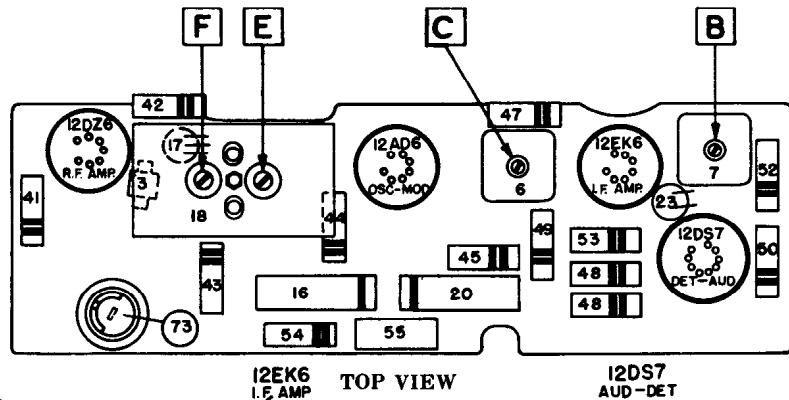
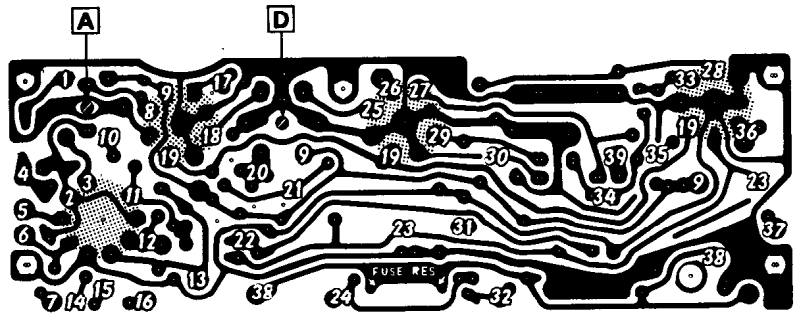

VOLTAGES MEASURED TERMINAL TO CHASSIS WITH A VTVM—NO SIGNAL AND 120 VOLTS AT ILLUS. 28.
 OSCILLATOR GRID VOLTAGE TAKEN WITH SET TUNED TO 1000 KC.
 TOTAL "A" DRAIN AT 12V.—1.6 AMPS.
 TOLERANCE ON VOLTAGES $\pm 10\%$.
 *—INDICATES LEAD FROM TUNER COIL ASS'Y.
 **—BEFORE MEASURING TRANSISTOR VOLTAGES, THE SHORTING TYPE SPEAKER SOCKET MUST BE OPENED AND A 4 OHM SPEAKER CONNECTED. IF TRANSISTOR IS REPLACED, ADJUST BIAS POTENTIOMETER (ILLUS. 73) TO OBTAIN PROPER COLLECTOR VOLTAGE WITH 12 VOLTS INPUT TO RADIO.
 †—ILLUS. 55 IS A FUSE RESISTOR FOR THE TRANSISTOR. SERVICE WITH EXACT REPLACEMENT.
 ⊖—OUTPUT TRANSFORMER WILL APPEAR SHORTED IF SHORTING TYPE SPEAKER SWITCH IS NOT HELD OPEN.

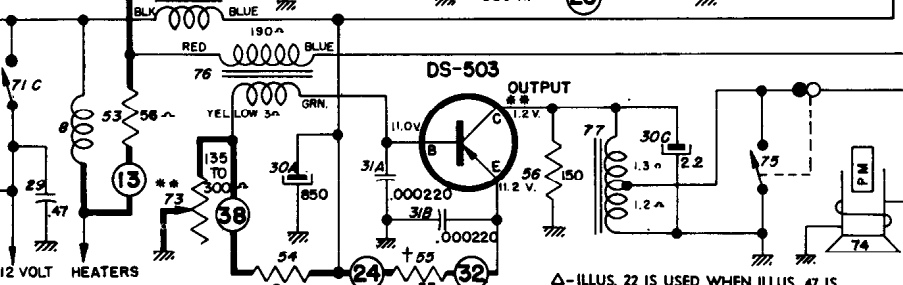

Δ—ILLUS. 22 IS USED WHEN ILLUS. 47 IS 150 OHMS.

BUICK 980132—PRINTED CIRCUIT SHOWN IN HEAVY LINES

DELCO

NEEDED 1961 RADIO SERVICING INFORMATION

BUICK MODEL 980134
Alignment in Table 1, Page 38

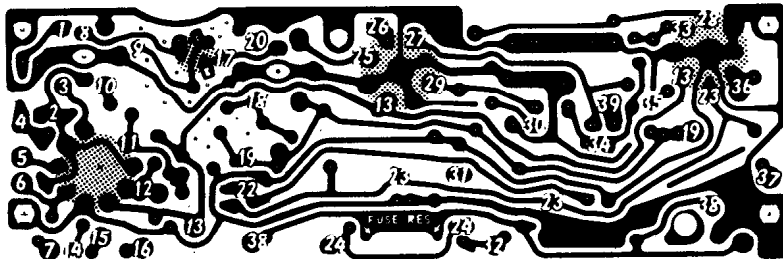

BOTTOM VIEW

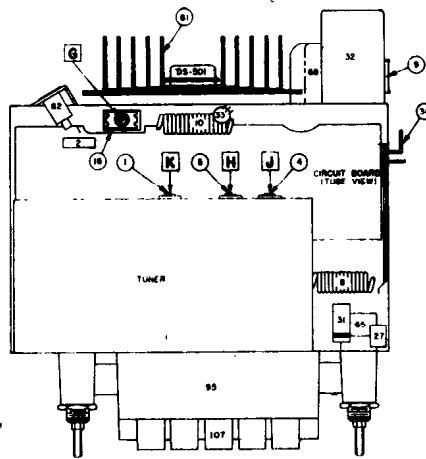

TUBE VIEW

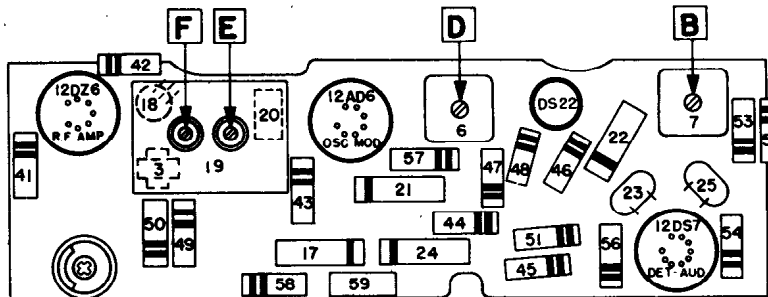

TOP VIEW

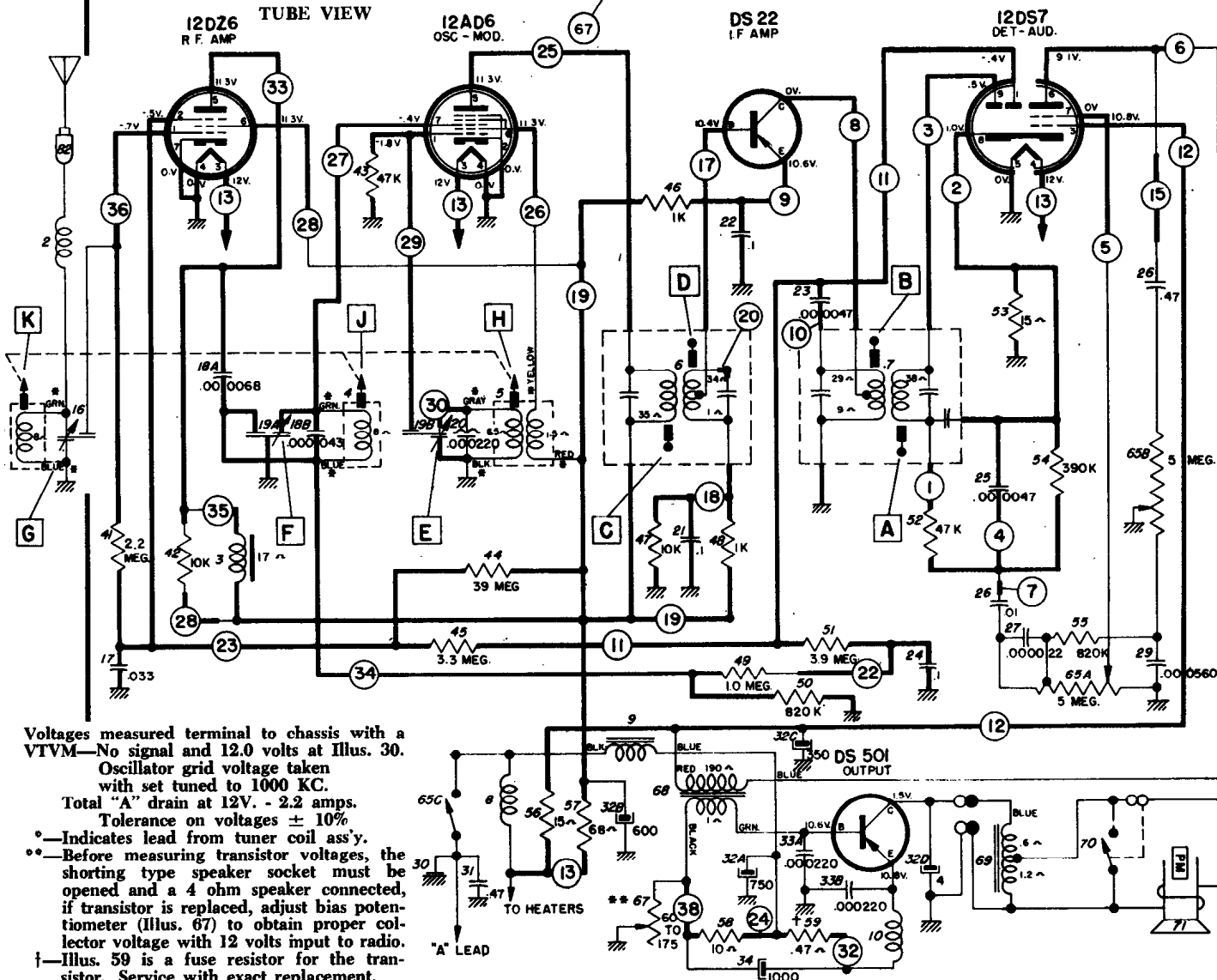

Volts measured terminal to chassis with a VTVM—No signal and 12.0 volts at Illus. 30. Oscillator grid voltage taken with set tuned to 1000 KC. Total "A" drain at 12V. - 2.2 amps. Tolerance on voltages $\pm 10\%$

- Indicates lead from tuner coil ass'y.
- Before measuring transistor voltages, the shorting type speaker socket must be opened and a 4 ohm speaker connected, if transistor is replaced, adjust bias potentiometer (Illus. 67) to obtain proper collector voltage with 12 volts input to radio.
- †—Illus. 59 is a fuse resistor for the transistor. Service with exact replacement.

NUMBERS ON PRINTED CIRCUIT BOARD CORRESPOND WITH NUMBERS IN CIRCLES ON SCHEMATIC

PRINTED CIRCUIT SHOWN IN HEAVY LINES

DELCO

CHEVROLET MODEL 988413
Alignment in Table 4, Page 38

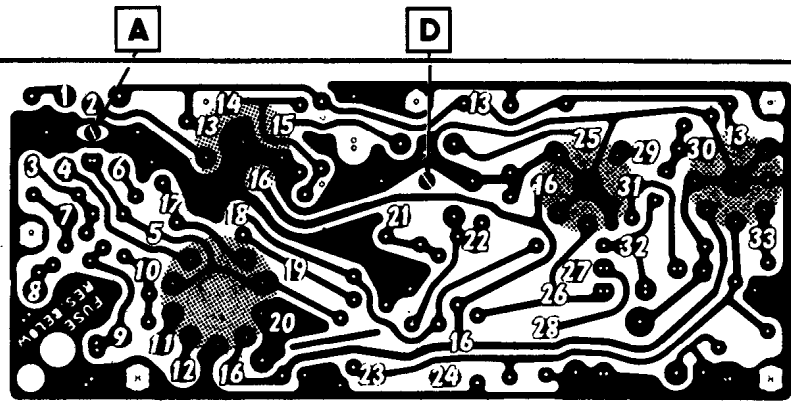

BOTTOM VIEW

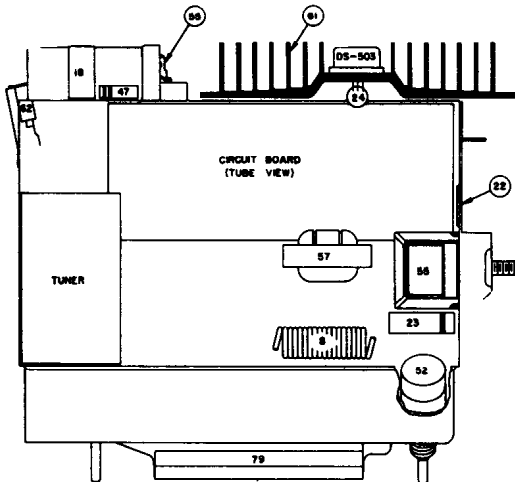

TUBE VIEW

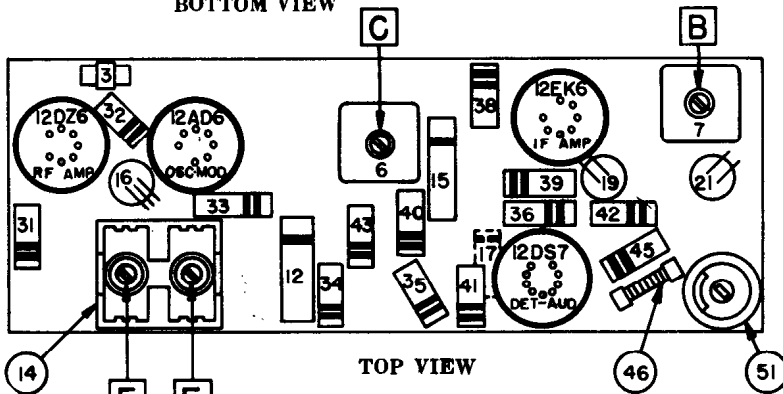

TOP VIEW

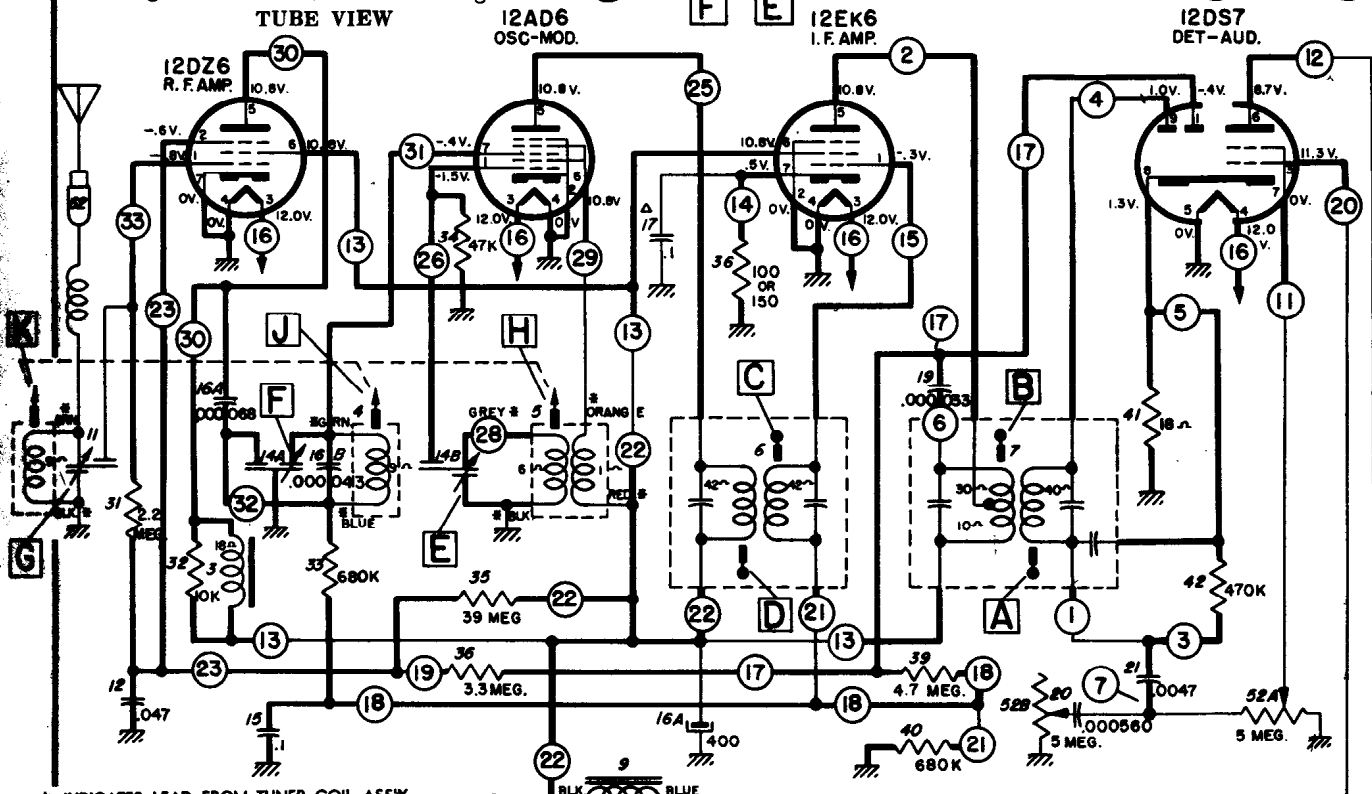

*- INDICATES LEAD FROM TUNER COIL ASS'Y.
Δ- THIS CAPACITOR WILL NOT APPEAR IN ALL RADIOS. (USED WHEN ILLUS. 38 IS 150 OHMS!)

VOLTAGES MEASURED TERMINAL TO CHASSIS WITH A VTVM-NO SIGNAL AND 12.0 VOLTS AT ILLUS. 22

OSCILLATOR GRID VOLTAGE TAKEN WITH SET TUNED TO 1000 KC.

TOTAL "A" DRAIN AT 12V. -1.6 AMPS.

TOLERANCE ON VOLTAGES ± 10%.
*- BEFORE MEASURING TRANSISTOR VOLTAGES, THE SHORTING TYPE SPEAKER SOCKET MUST BE OPENED AND A 4 OHM SPEAKER CONNECTED. IF TRANSISTOR IS REPLACED, ADJUST BIAS POTENTIOMETER ILLUS. 511 TO OBTAIN PROPER COLLECTOR VOLTAGE WITHIN 12 VOLTS INPUT TO RADIO.

VOLUME R-21, MOST-OFTEN-NEEDED 1961 RADIO SERVICING INFORMATION

DELCO
CHEVROLET MODEL 988414
Alignment in Table 1, Page 38

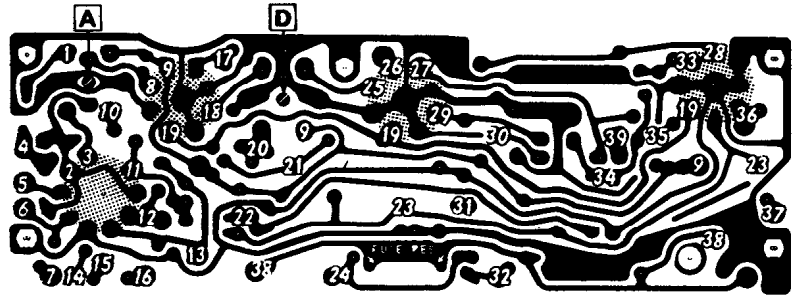
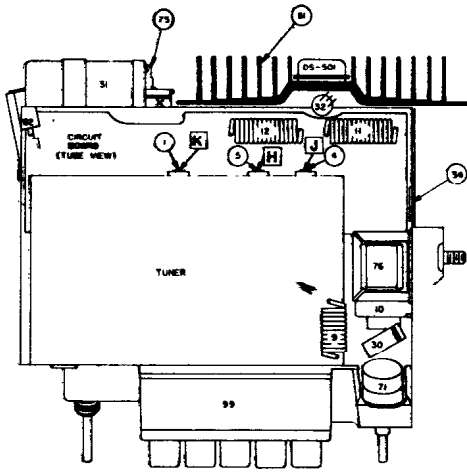

BOTTOM VIEW

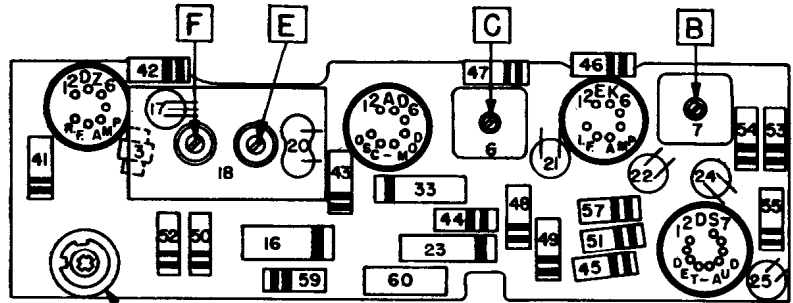

TOP VIEW

I2DZ6
R.F. AMP.

I2AD6
OSC-MOD

I2EK6
L.F. AMP.

I2DS7
DET - AUO

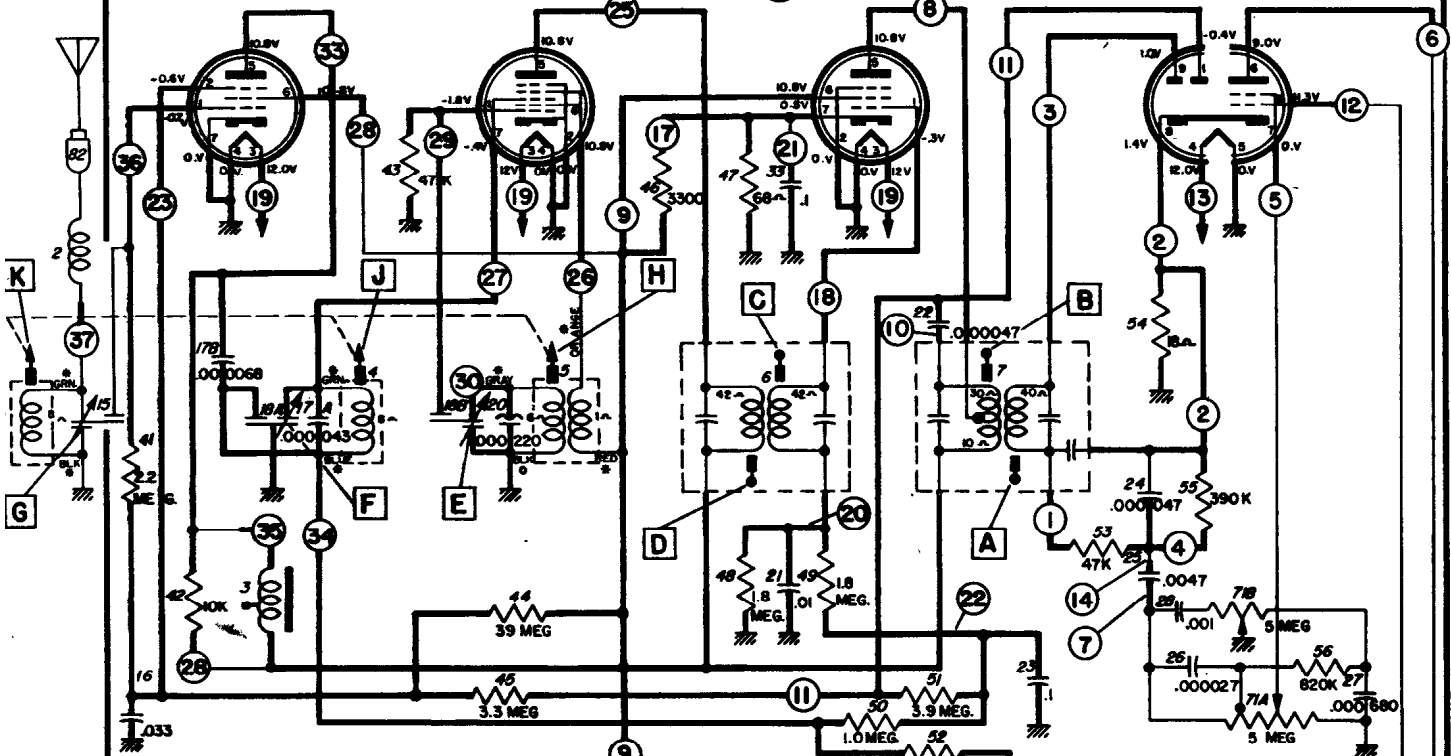

Voltages measured terminal to chassis with a VTVM—No signal and 12.0 volts at illus. 34
Oscillator grid voltage taken with set tuned to 1000 KC.
Total "A" drain at 12V. - 2.2 amps.
Tolerance on voltages $\pm 10\%$
*—Indicates lead from tuner coil ass'y.
**—Before measuring transistor voltages, the shorting type speaker socket must be opened and a 4 ohm speaker connected, if transistor is replaced, adjust bias potentiometer (illus. 73) to obtain proper collector voltage with 12 volts input to radio.
†—illus. 60 is a fuse resistor for the transistor. Service with exact replacement.

CHEVROLET 988414

TO FUSE BLOCK TO HEATERS

PRINTED CIRCUIT SHOWN IN HEAVY LINES.

VOLUME R-21, MOST-OFTEN

DELCO
CHEVROLET CORVAIR 988468
Alignment in Table 1, Page 38

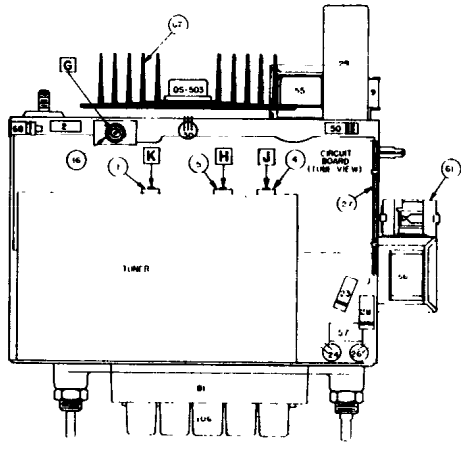

TUBE VIEW

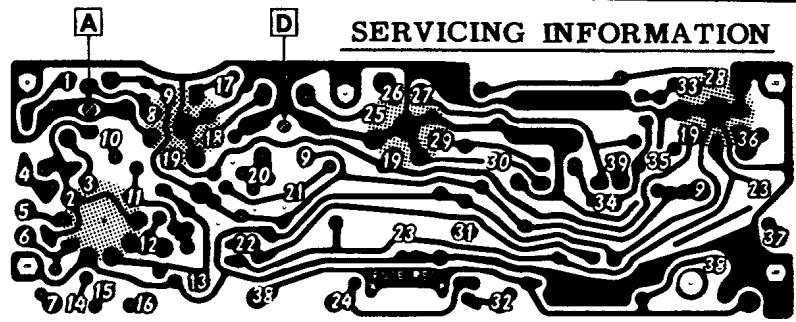

BOTTOM VIEW

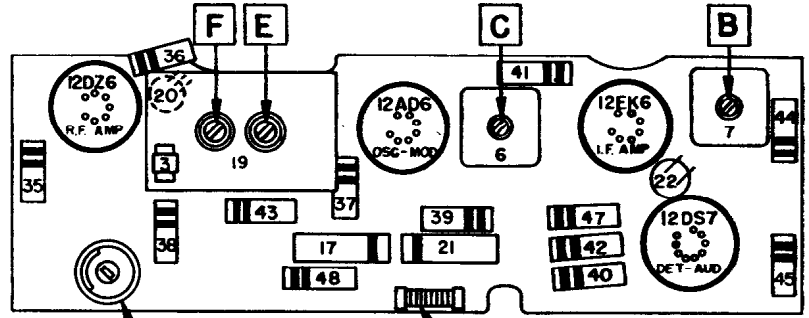

TOP VIEW

12DZ6
R.F. AMP.

12AD6
OSC-MOD.

12EK6
L.F. AMP.

12DS7
DET-AUD.

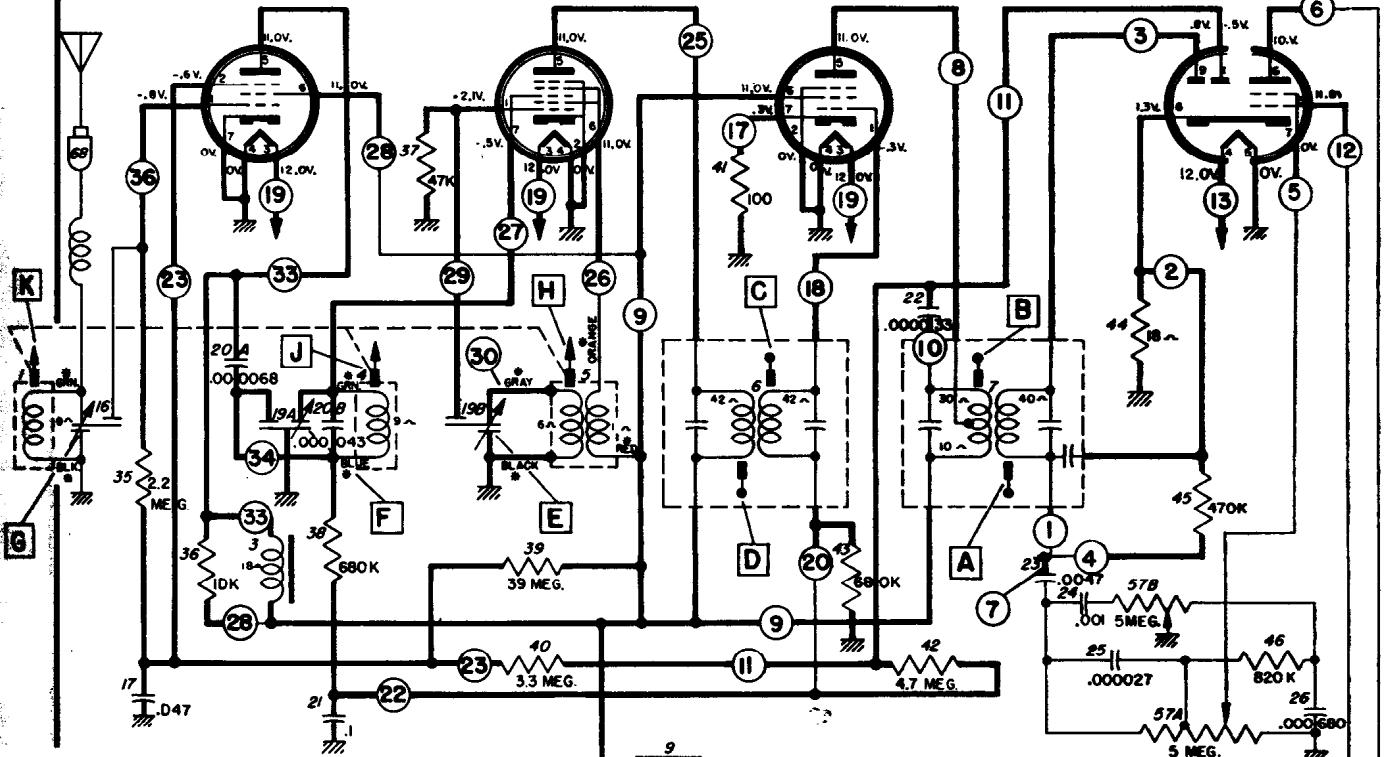

Voltages measured terminal to chassis with a VTVM—No signal and 12.0 volts at illus. 27
Oscillator grid voltage taken with set tuned to 1000 KC.
Total "A" drain at 12V. - 1.6 amps.
Tolerance on voltages $\pm 10\%$
—Indicates lead from tuner coil ass'y.
—Before measuring transistor voltages, the shorting type speaker socket must be opened and a 4 ohm speaker connected, if transistor is replaced, adjust bias potentiometer (illus. 58) to obtain proper collector voltage with 12 volts input to radio.
—illus. 49 is a fuse resistor for the transistor. Service with exact replacement.

CHEVROLET CORVAIR 988468

FUSE BLOCK

DS503
OUTPUT

PRINTED CIRCUIT SHOWN IN HEAVY LINES.

DELCO

OLDSMOBILE MODEL 989392
Alignment in Table 2, Page 38

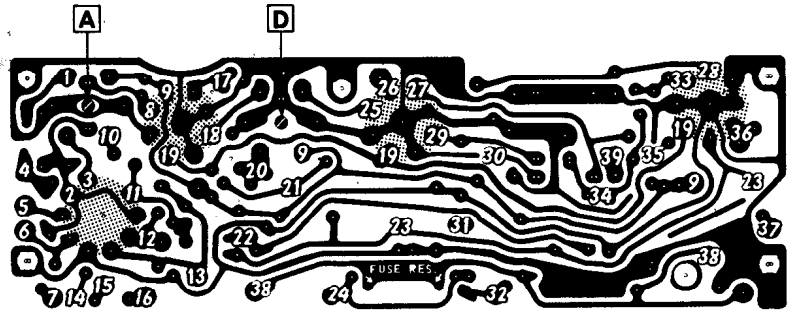

PRINTED VIEW

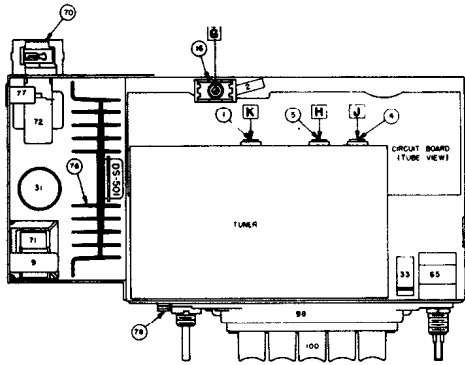

TUBE VIEW

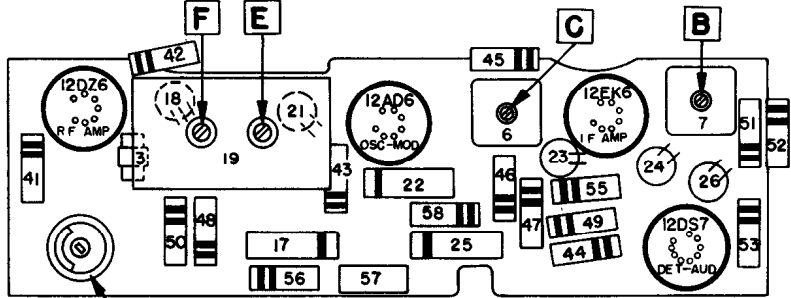

PARTS VIEW

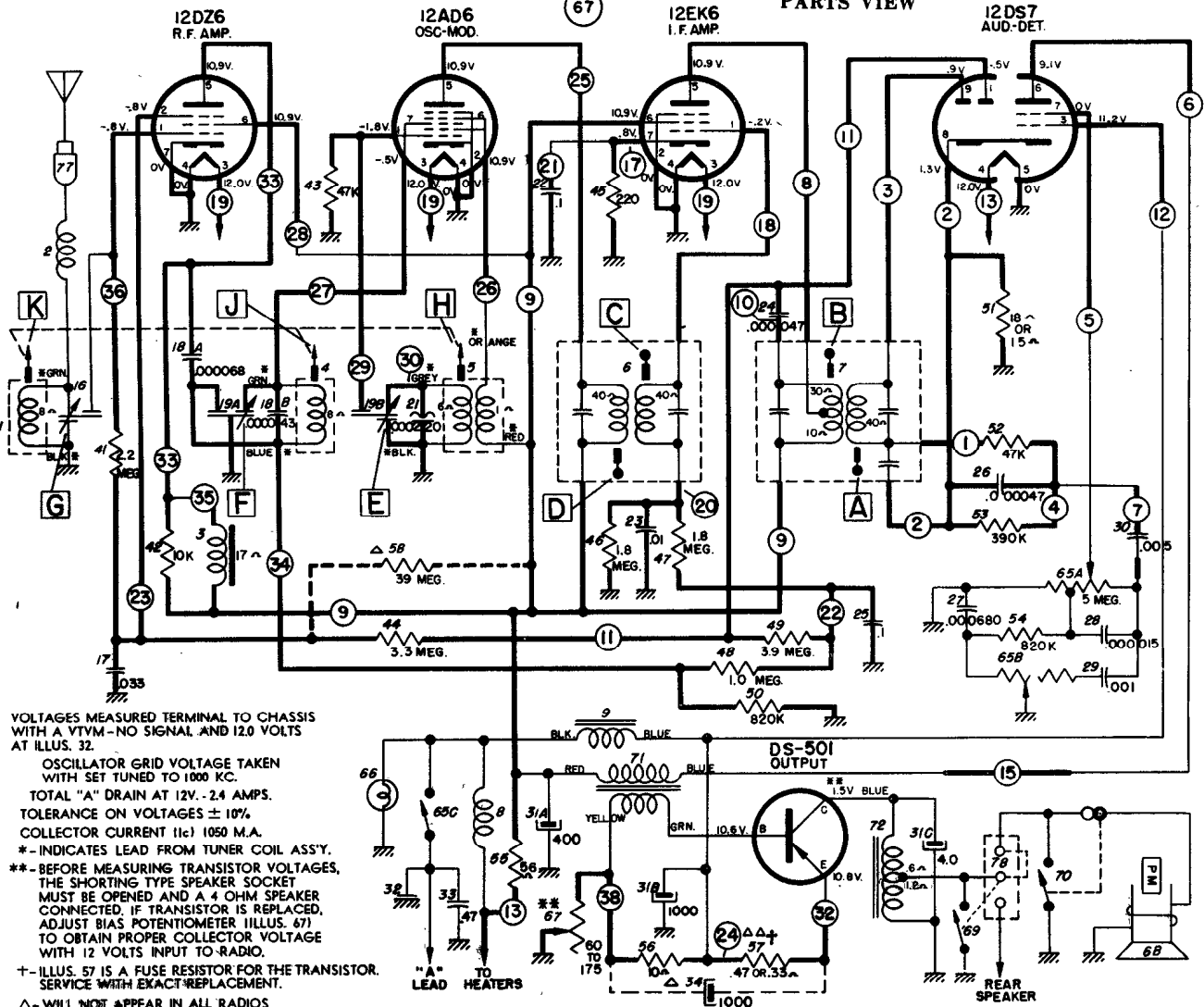

VOLTAGES MEASURED TERMINAL TO CHASSIS WITH SET TUNED TO 1000 KC. AND 12.0 VOLTS AT ILLUS. 32.

OSCILLATOR GRID VOLTAGE TAKEN WITH SET TUNED TO 1000 KC.

TOTAL "A" DRAIN AT 12V. -2.4 AMPS.

TOLERANCE ON VOLTAGES $\pm 10\%$

COLLECTOR CURRENT (IC) 1050 M.A.

* - INDICATES LEAD FROM TUNER COIL ASSY.

** - BEFORE MEASURING TRANSISTOR VOLTAGES, THE SHORTING TYPE SPEAKER SOCKET MUST BE OPENED AND A 4 OHM SPEAKER CONNECTED. IF TRANSISTOR IS REPLACED, ADJUST BIAS POTENTIOMETER ILLUS. 671 TO OBTAIN PROPER COLLECTOR VOLTAGE WITH 12 VOLTS INPUT TO RADIO.

+ - ILLUS. 57 IS A FUSE RESISTOR FOR THE TRANSISTOR. SERVICE WITH EXACT REPLACEMENT.

Δ - WILL NOT APPEAR IN ALL RADIOS

$\Delta\Delta$ - 33 OHM MUST BE USED WHEN ILLUS. 34 IS NOT PRESENT.

OLDSMOBILE 989392—PRINTED CIRCUIT SHOWN IN HEAVY LINES

DELCO

PONTIAC MODEL 989693
Alignment in Table 2, Page 38

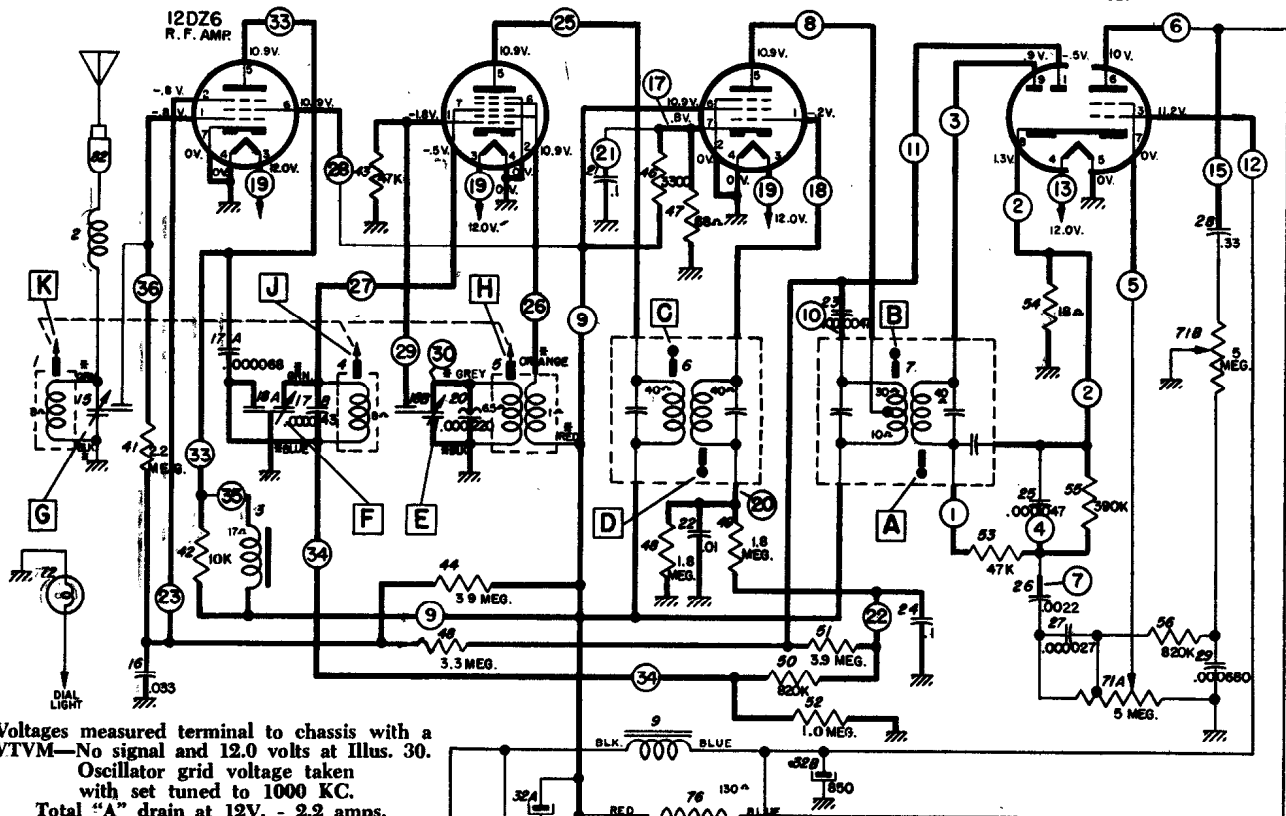
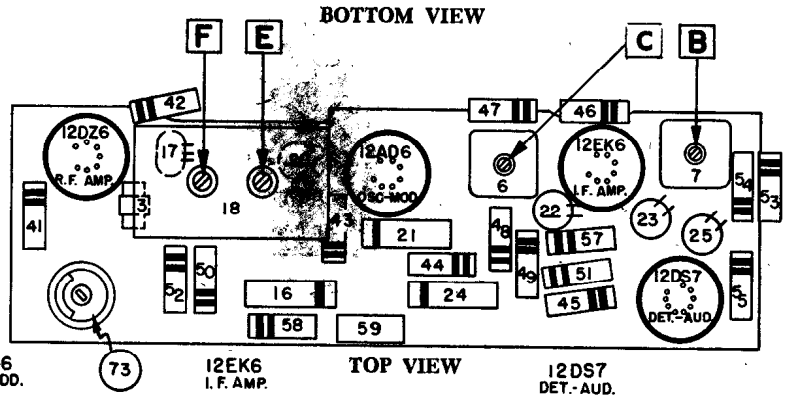
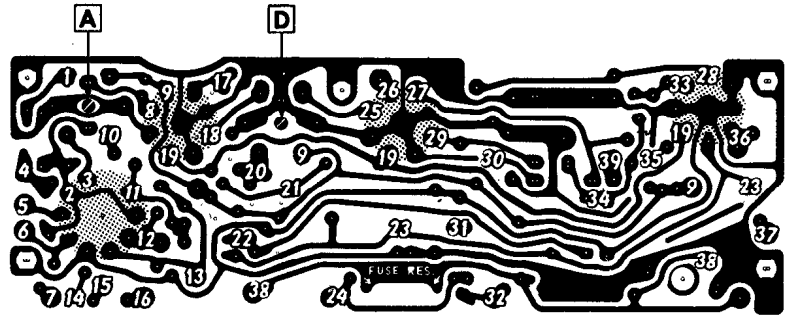
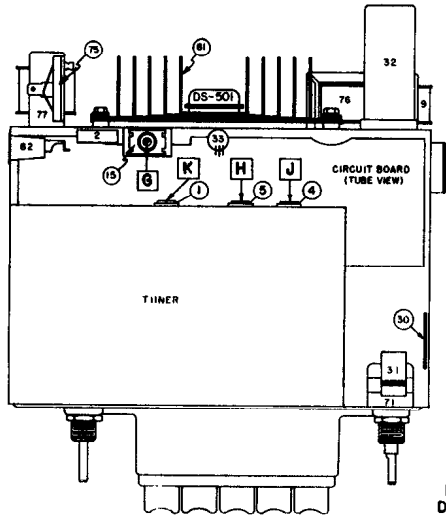

Voltages measured terminal to chassis with a VTVM—No signal and 12.0 volts at illus. 30.
Oscillator grid voltage taken with set tuned to 1000 KC.
Total "A" drain at 12V. - 2.2 amps.
Transistor collector current—1 amp.
Tolerance on voltages $\pm 10\%$
*—Indicates lead from tuner coil ass'y.
**—Before measuring transistor voltages, the shorting-type speaker socket must be opened and a 4 ohm speaker connected, if transistor is replaced, adjust bias potentiometer (illus. 73) to obtain proper collector voltage with 12 volts input to radio.
†—illus. 59 is a fuse resistor for the transistor. Service with exact replacement.

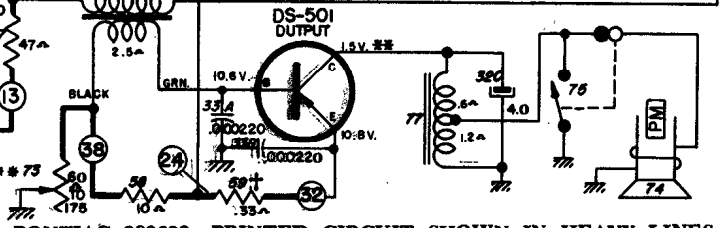

PONTIAC 989693—PRINTED CIRCUIT SHOWN IN HEAVY LINES.

VOLUME R-21, MOST-OFTEN-NEEDED 1961 RADIO SERVICING INFORMATION

DELCO Alignment Procedure for Various 1961 Auto Radios

Output Meter Connections Across Voice Coil
 Generator Return To Receiver Chassis
 Dummy Antenna In Series With Generator
 Volume Control Position Maximum Volume
 Generator Output Minimum for Readable Indication

TABLE 1, Alignment for Buick 980134, Chevrolet 988414, Chevrolet Corvair 988468

STEP	SERIES CONDENSER OR DUMMY ANTENNA	CONNECT SIGNAL GENERATOR TO	SIGNAL GENERATOR FREQUENCY	TUNE RECEIVER TO	ADJUST IN SEQUENCE FOR MAX OUTPUT
1	0.1 Mfd.	12AD6 Grid (Pin #7)	262 KC	High Frequency Stop	A, B, D, C
2	.000082 Mfd.	Antenna Connector	1615 KC	High Frequency Stop	*E, F, G
3	.000082 Mfd.	Antenna Connector	600 KC	Signal Generator Signal	J, K
4	.000082 Mfd.	Antenna Connector	1615 KC	High Frequency Stop	F, G
5	.000082 Mfd.	Antenna Connector	1100 KC	Signal Generator Signal	L**

TABLE 2, Alignment for Oldsmobile 989392 and Pontiac Model 989693

STEPS	SERIES CAPACITOR OR DUMMY ANTENNA	CONNECT SIGNAL GENERATOR TO	SIGNAL GENERATOR FREQUENCY	TUNE RECEIVER TO	ADJUST IN SEQUENCE FOR MAX. OUTPUT
1	0.1 Mfd.	12AD6 Grid (Pin #7)	262 KC	High Frequency Stop	A, B, C, D
2	0.000068 Mfd.	Antenna Connector	1615 KC	High Frequency Stop	*E, F, G
3	0.000068 Mfd.	Antenna Connector	600 KC	Signal Generator Signal	J, K
4	0.000068 Mfd.	Antenna Connector	1615 KC	High Frequency Stop	F, G
5	0.000068 Mfd.	Antenna Connector	1100 KC	Signal Generator Signal	L**

TABLE 3, Alignment for Buick 980132 and Oldsmobile Model 989387

STEPS	SERIES CONDENSER OR DUMMY ANTENNA	CONNECT SIGNAL GENERATOR TO	SIGNAL GENERATOR FREQUENCY	TUNE RECEIVER TO	ADJUST IN SEQUENCE FOR MAX. OUTPUT
1	0.1 Mfd.	12AD6 Grid (Pin #7)	262 KC	High Frequency Stop	A, B, D, C
2	.000082 Mfd.	Antenna Connector	1615 KC	High Frequency Stop	*E, F, G
3	.000082 Mfd.	Antenna Connector	600 KC	Signal Generator Signal	J, K
4	.000082 Mfd.	Antenna Connector	1615 KC	High Frequency Stop	F, G
5	.000082 Mfd.	Antenna Connector	900 KC	Signal Generator Signal	L***

TABLE 4, Alignment for Chevrolet Model 988413

STEPS	SERIES CAPACITOR OR DUMMY ANTENNA	CONNECT SIGNAL GENERATOR TO	SIGNAL GENERATOR FREQUENCY	TUNE RECEIVER TO	ADJUST IN SEQUENCE FOR MAX. OUTPUT
1	0.1 Mfd.	12AD6 Grid (Pin #7)	262 KC	High Frequency Stop	A, B, C, D,
2	0.000082 Mfd.	Antenna Connector	1615 KC	High Frequency Stop	*E, F, G,
3	0.000082 Mfd.	Antenna Connector	600 KC	Signal Generator Signal	J, K
4	0.000082 Mfd.	Antenna Connector	1615 KC	High Frequency Stop	F, G

*Before making this adjustment check mechanical setting of oscillator core "H." The rear of the core should be 1/8" from the mounting end of the coil form. (This measurement is readily made by inserting a suitable plug in the mounting end of the coil form.) Core adjustment should be made with a non-metallic screw driver.

**L is the pointer adjustment screw which is on the connecting link, between the pointer assembly and the parallel guide bar. It should be adjusted so that the dial pointer corresponds with the 1100 K.C. mark on the dial.

***L is the pointer adjustment screw which is on the connecting link, between the pointer assembly and the parallel guide bar. It should be adjusted so that the dial pointer corresponds with the 900 KC mark on the dial.

With the radio installed and the car antenna plugged in, adjust the antenna trimmer "G" for maximum volume with the radio tuned to a weak station between 600 and 1000 KC (see sticker on case.)

EMERSON Models 907B, 926B

EMERSON RADIO
 Model 907B, Chassis 120478B
 Model 926B, Chassis 120505B

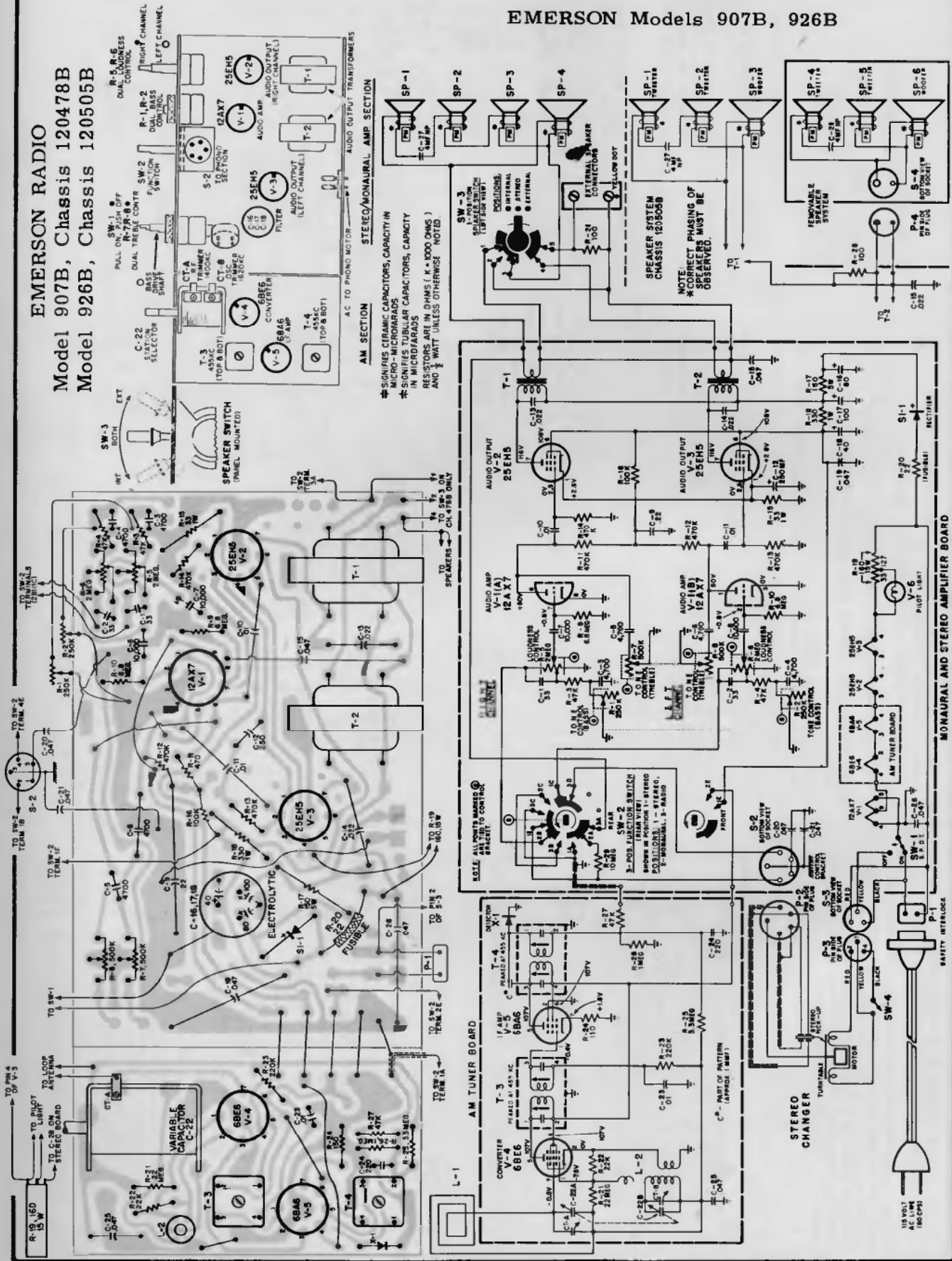

EMERSON RADIO
Models 920 and 925
Chassis 120494B

1. Voltages indicated are positive DC, resistances in ohms, unless otherwise indicated.
2. Measurements made with Voltohmyst or equivalent.
3. All measurements taken between pin and chassis ground.
4. All voltage measurements taken under the following conditions:
 - a) Line voltage maintained at 117 volts.
 - b) Tuning control turned fully counterclockwise (low end)

1. Voltages indicated are positive DC, resistances in ohms, unless otherwise indicated.

2. Measurements made with Voltohmyst or equivalent.

3. All measurements taken between pin and chassis ground.

4. All voltage measurements taken under the following conditions:

a) Line voltage maintained at 117 volts.

b) Tuning control turned fully counterclockwise (low end)

I.F. ALIGNMENT PROCEDURE USING R.F. GENERATOR AND VTVM

Use of this method requires balancing of the ratio detector output before attempting alignment. To accomplish this, construct a voltage divider network by placing two 100 k resistors in series and wire them across C-17 (2 mid. stabilizer capacitor). Be sure to remove this network after completion of the alignment procedure.

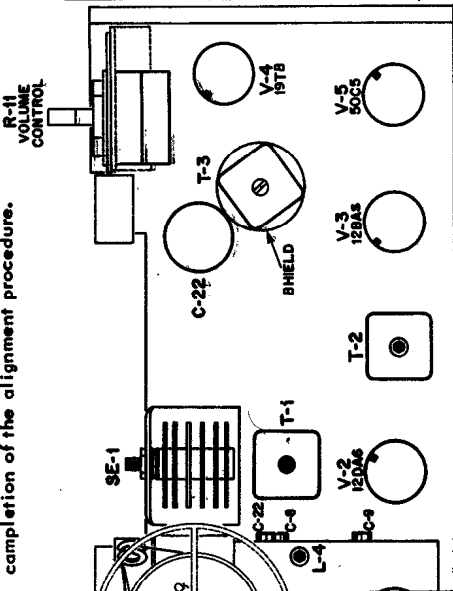

STEP	SIGNAL GENERATOR		DIAL SETTING	VTVM	ADJUST	REMARKS
	COUPLING	FREQUENCY				
1.	High side to ant. input, low side to chassis through a .25 mfd. capacitor.	10.7 MC (unmod.)	Extreme CCW pos. (low end)	Across C-17 (near V-4). Use negative scale.	T-3 bottom, T-2 top, T-1 (1st IF), L-4 mixer coil.	Adjust in order given for max. neg. voltage. Maintain sig. gap, output for readings under 2 volts.
2.	" "	" "	" "	" "	T-1 (1st IF)	Return for max. neg. voltage.
3.	" "	" "	" "	One side of center-tap of voltage divider network across C-17, other side to junction of R-8, C-14.	T-3 Top	Adjust for 0 volts output between pos. and neg. meter swing.

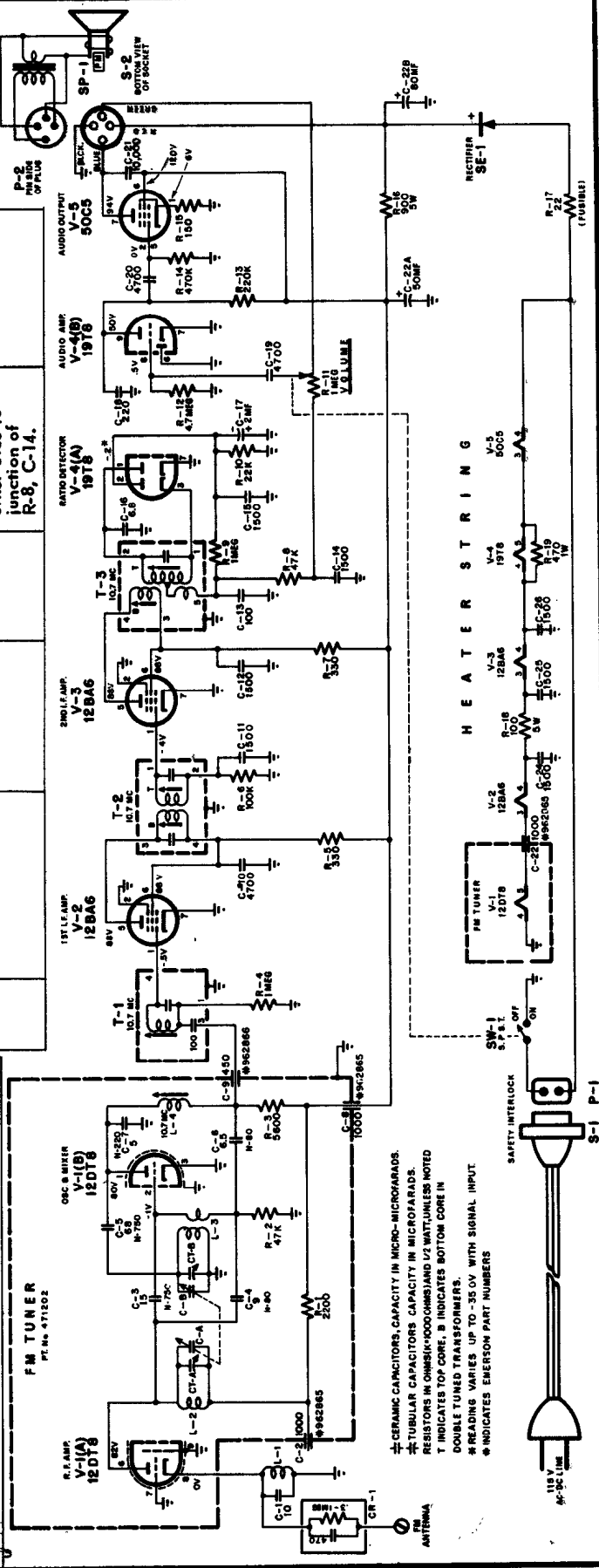

⊕ CERAMIC CAPACITORS, CAPACITY IN MICRO-MICROFARADS.
 ⊕ TUBULAR CAPACITORS, CAPACITY IN MICROFARADS.
 RESISTORS IN OHMS; K=1000 OHMS; M=1/2 WATT; UNLESS NOTED
 T INDICATES TOP CORE, B INDICATES BOTTOM CORE IN
 DOUBLE TUNED TRANSFORMERS.
 * READING VARIES UP TO .35 OV WITH SIGNAL INPUT
 † INDICATES EMERSON PART NUMBERS

VOLUME R-21, MOST-OFTEN-NEEDED 1961 RADIO SERVICING INFORMATION

EMERSON RADIO Model 933B, Chassis 120547B

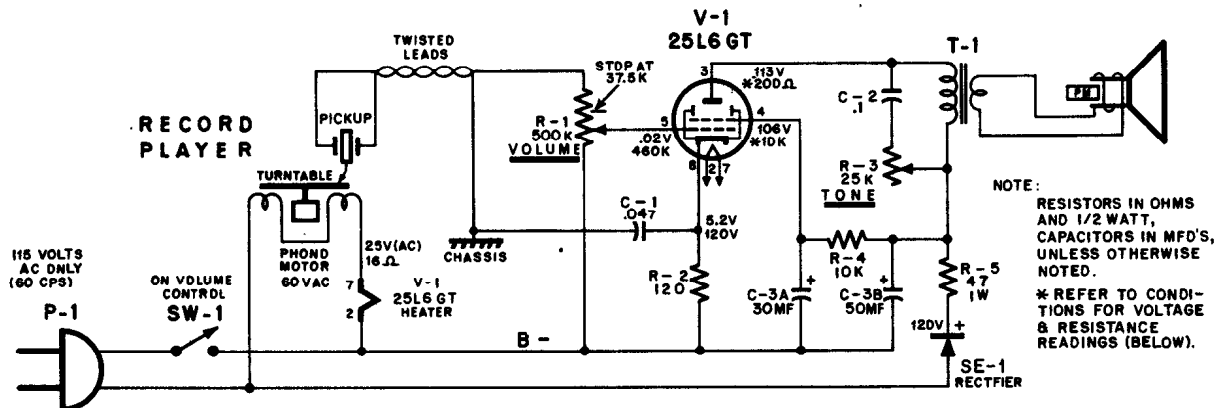

EMERSON RADIO Model 935B, Chassis 120548B

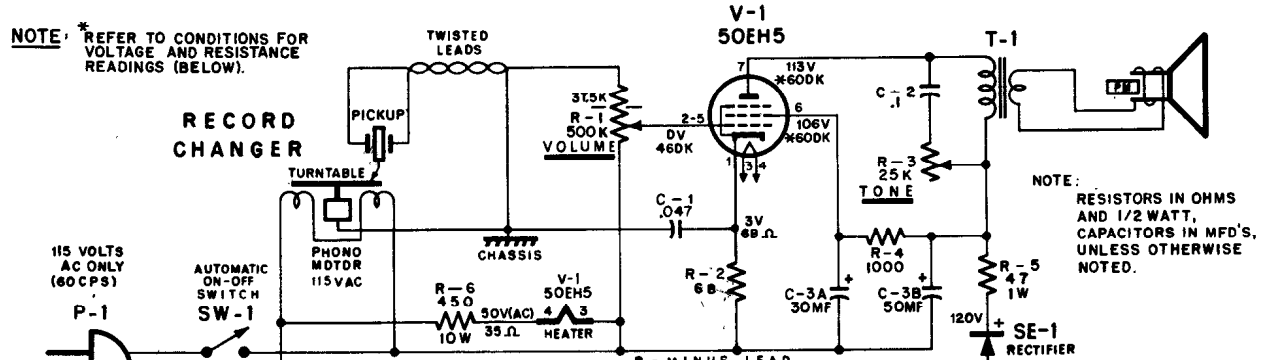

CONDITIONS FOR VOLTAGE AND RESISTANCE READINGS

1. Voltages indicated are positive d.c., resistances in ohms, unless otherwise indicated.
2. Measurements made with voltohmmyst or equivalent.
3. All measurements taken from pin to B minus unless otherwise indicated.
4. Voltage measurements taken with:
 - a) Line voltage maintained at 115 volts a.c.
 - b) Volume control set for maximum volume.
5. Resistance measurements taken with:
 - a) Power line cord disconnected from outlet.
 - b) Volume control set for maximum volume.
6. Nominal tolerance on component values makes possible a variation of $\pm 15\%$ in voltage and resistance readings,
7. N.C. denotes no connection, K is kilohms, Meg. is megohms.
8. Resistances marked with * vary due to capacitor charge. Allow about 30 seconds for meter to settle.

EMERSON RADIO Model 937B, Chassis 120558B

DISASSEMBLY INSTRUCTIONS

1. Remove 2 Phillips head screws used to secure record changer to cabinet.
2. Lift changer and cardboard mounting escutcheon up and tilt backwards. Do not disconnect any leads.
3. Remove both volume control knobs from cabinet front.
4. Disconnect leads for both the left and right channel loudspeakers from their respective output transformers. NOTE: Care should be taken to mark all speaker leads before disassembly to insure their proper connection during re-assembly.
5. Remove two pinnuts used to secure chassis to cabinet and free line cord from fishpaper harness stapled to cabinet.
6. Slide chassis to rear and lift both record changer and chassis from cabinet.
7. Re-assemble in reverse order.

CHASSIS
 B - INVERT TO BE SHORTED TO CHASSIS
 RESISTORS IN OHMS (K = 1000) AND 1/2 WATT UNLESS NOTED.
 CAPACITORS IN MICROFARADS

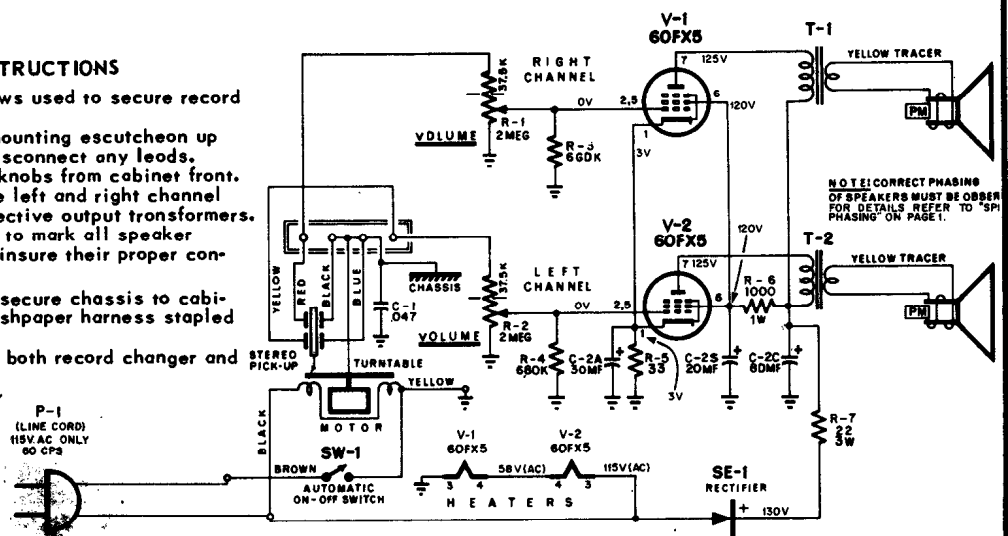

EMERSON RADIO Model 938B, Chassis 120559B

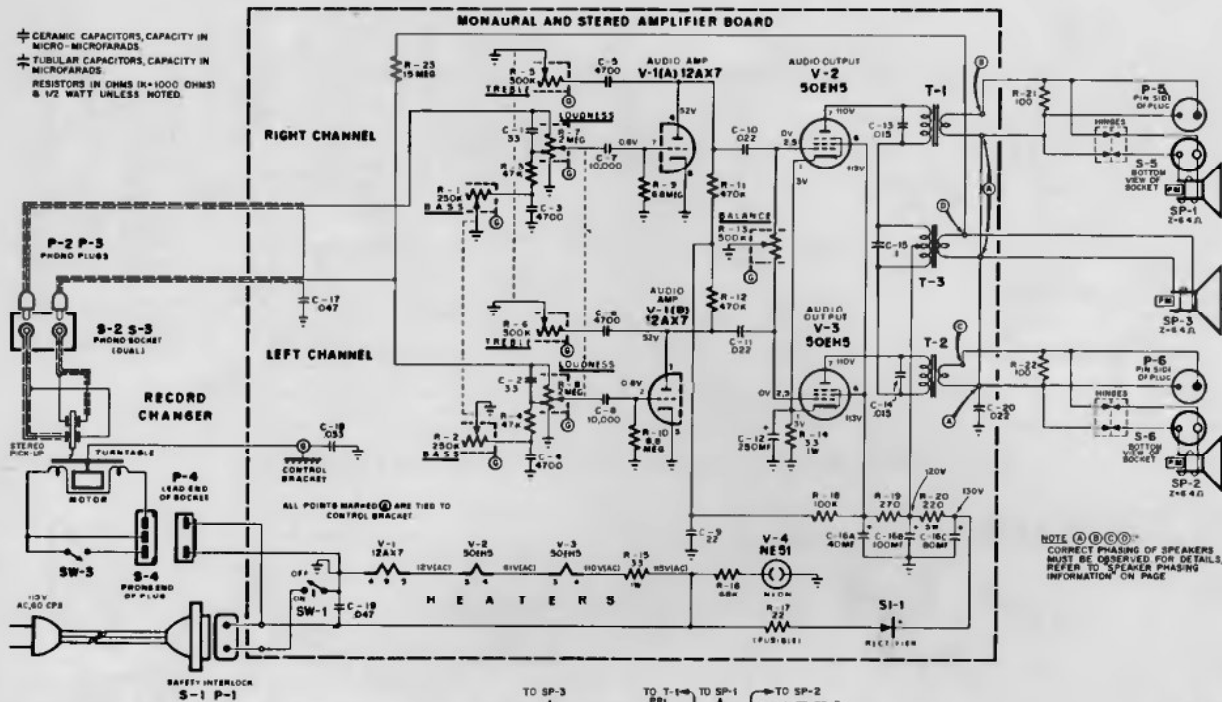

Voltage measurements taken with:
 A) Line voltage maintained at 115 volts A.C.
 B) Loudness control set for minimum volume.
 C) Record changer in "off" position.

MODEL: 938-B
CHASSIS 120559-B

TO REMOVE CHASSIS

Remove record changer and mounting board assembly as outlined above.
 Remove knobs from amplifier control panel at front of cabinet.
 Remove screws used to secure AC interlock bracket to cabinet.
 Slide pilot light and socket assembly from its holder.
 Unclip connectors for the right channel, center channel and left channel loudspeakers from their respective terminals.

NOTE: Care must be taken to mark all speaker leads in some manner before disconnecting, to assure proper re-connection of each during re-assembly.

Remove four Palnuts used to secure chassis and remove chassis from cabinet.
 Re-assemble in reverse order.

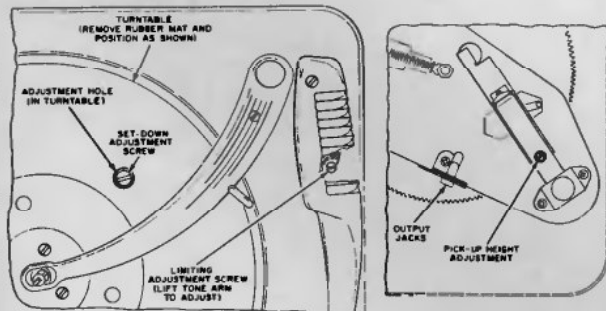

RECORD CHANGER 819170, ADJUSTMENT SETTINGS

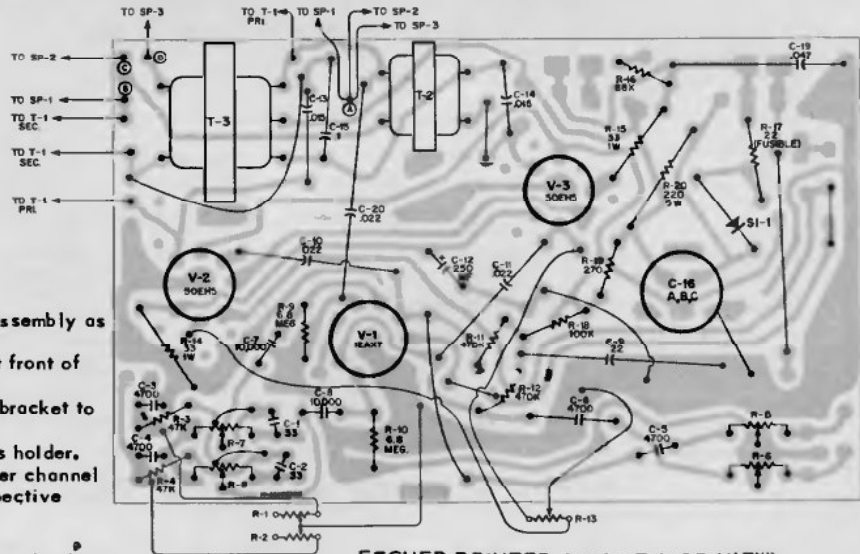

ETCHED PRINTED CIRCUIT (TOP VIEW)

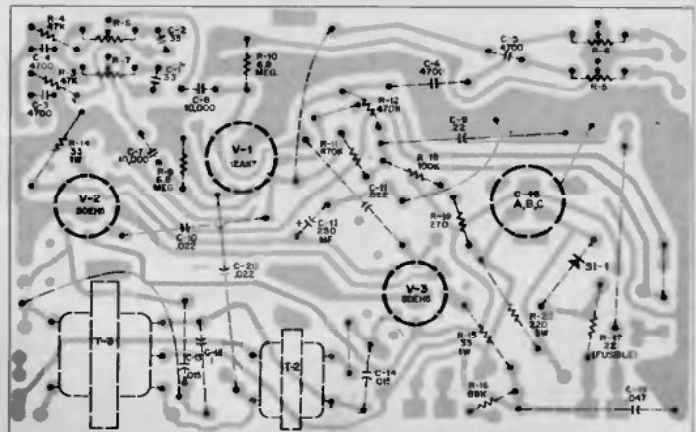

ETCHED PRINTED CIRCUIT (BOT. VIEW)

Emerson

MODEL: 977
 'FALCON'
 CHASSIS 120528

PUSH-PULL
 AUDIO OUTPUT
 Q-6

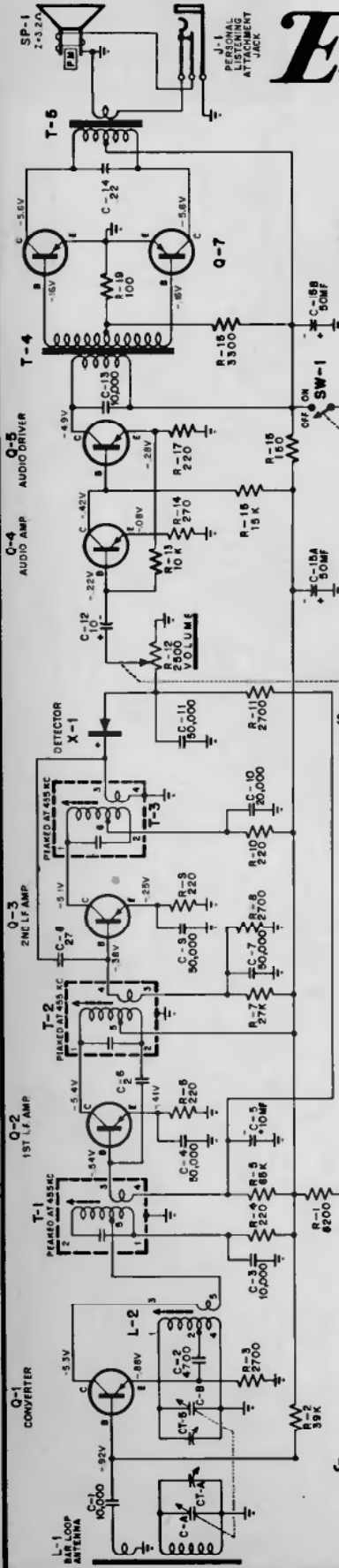

RESISTORS ARE IN OHMS (K=1000 OHMS)
 AND 1/2 WATT

RESISTORS ARE IN OHMS (K=1000 OHMS)
 AND 1/2 WATT

CONDITIONS FOR VOLTAGE READINGS, CHASSIS 120528

1. Voltages indicated are negative D.C. chassis.
 2. All measurements taken between points and chassis.
 3. Voltage measurements taken with:
 - (a) VTVM
 - (b) Fresh 6 Volt battery supply. Four 1 1/2 Volt conventional penlight cells.
- NOTE: Should Mercury or Nickel-Cadmium batteries be used, an approx. 15% lower voltage reading will be obtained from the battery supply which is considered to be perfectly normal. Bear in mind that the voltage supply will vary slightly with the type and condition of batteries used.
- (c) Volume control set for maximum volume.
 (d) Variable capacitor fully closed and no signal applied.

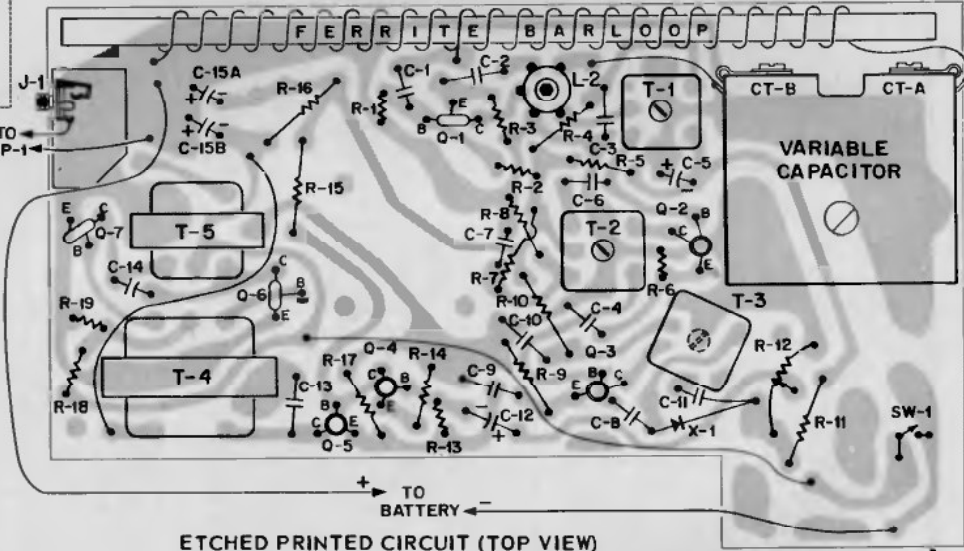
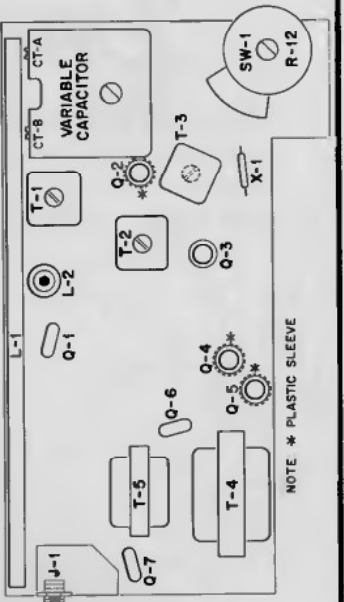

ETCHED PRINTED CIRCUIT (TOP VIEW)

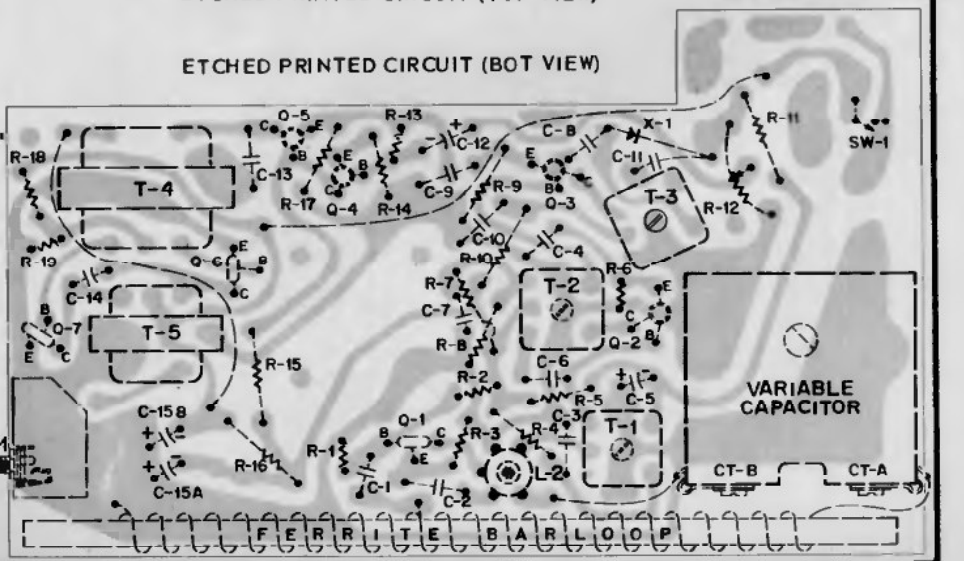

ETCHED PRINTED CIRCUIT (BOT VIEW)

Emerson Radio

Model 944B, using Audio 120522B and Tuner 120523B, has essential information on this page and the next page adjacent at right. Model 914B, using Tuner 120482B and Audio 120483B, is very similar to this combination.

MODEL 944-B
CH-120522-B (AUDIO)
CH-120523-B (TUNER)

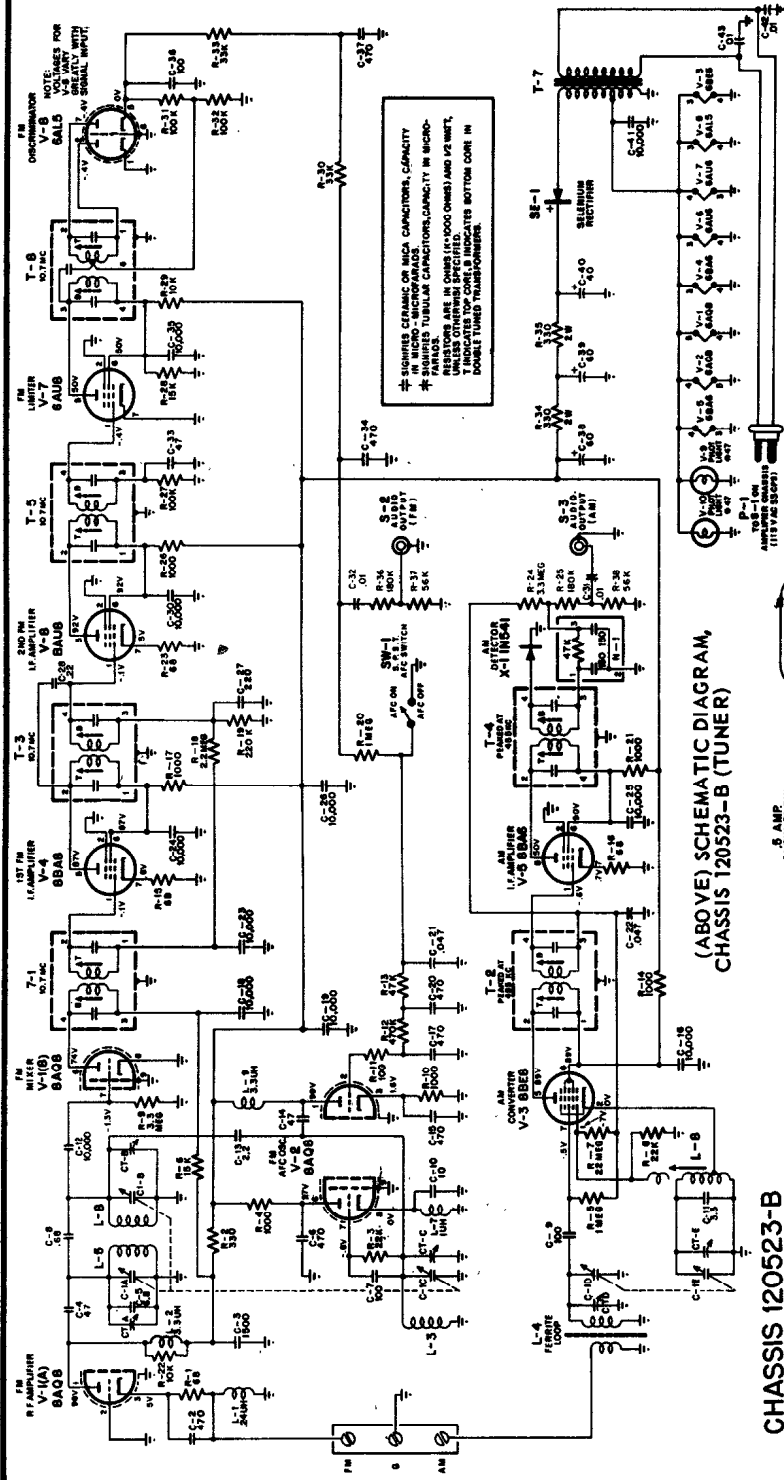

(ABOVE) SCHEMATIC DIAGRAM, CHASSIS 120523-B (TUNER)

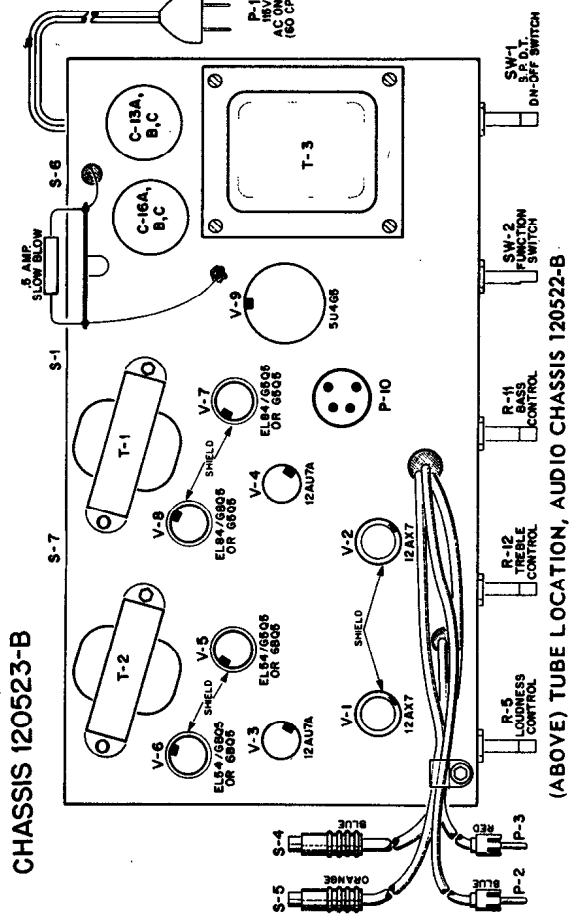
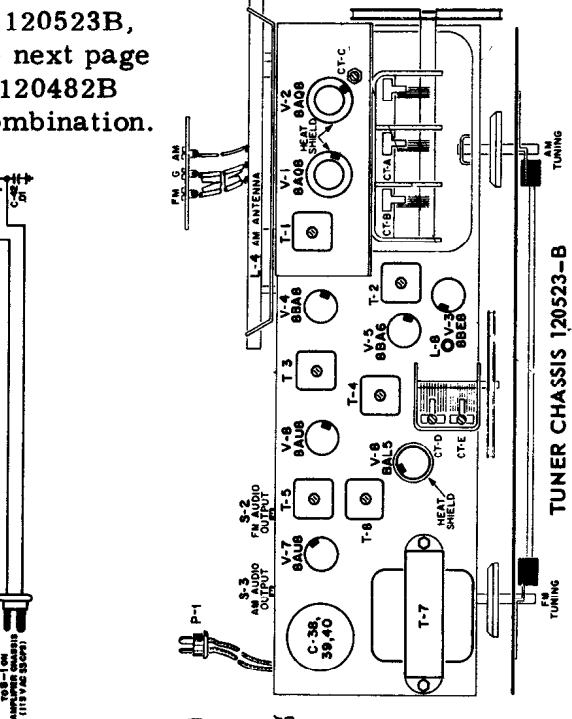

(ABOVE) TUBE LOCATION, AUDIO CHASSIS 120522-B

SCHEMATIC DIAGRAM, CHASSIS 120522-B (AUDIO)

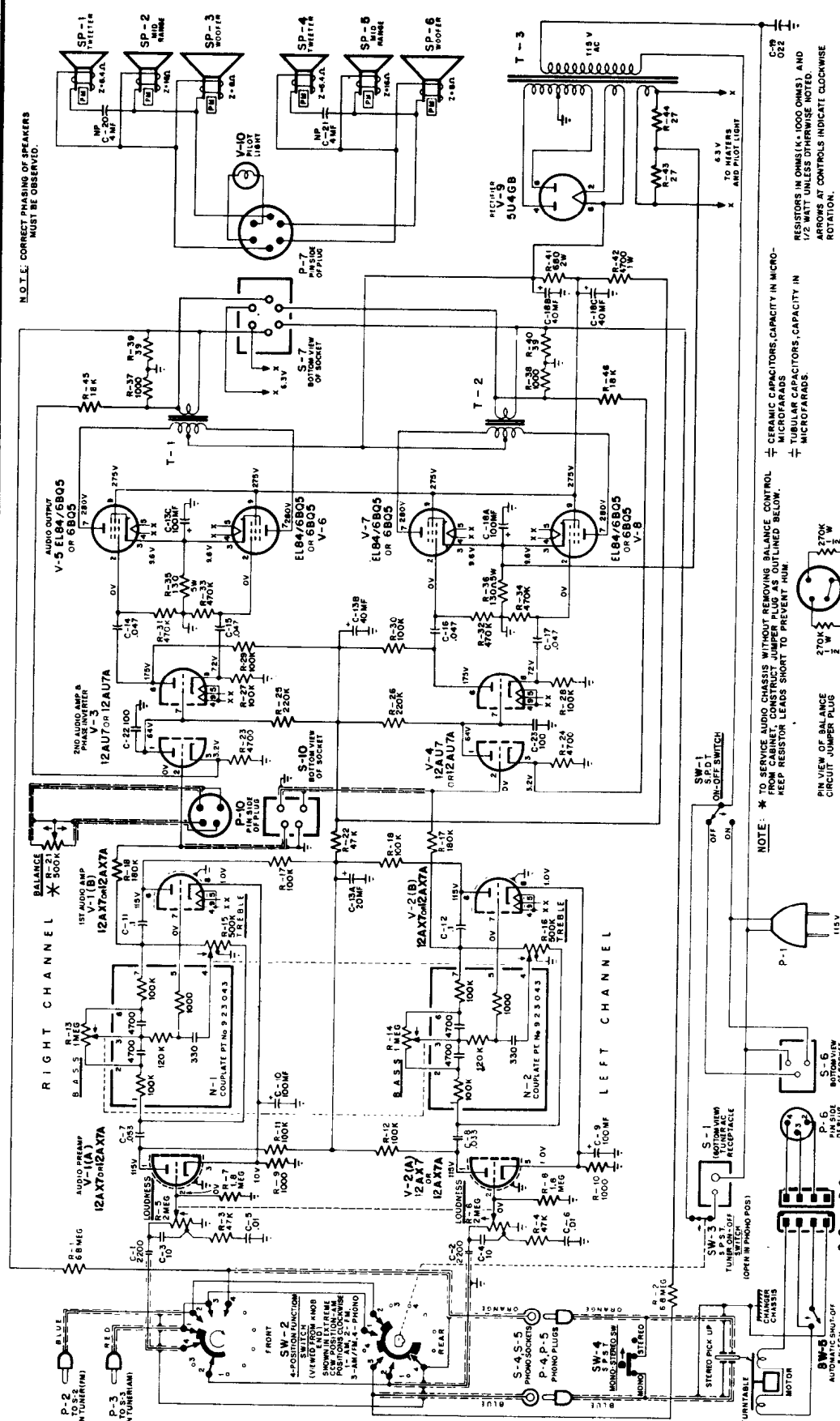

N.O.T.E.: CORRECT PHASING OF SPEAKERS MUST BE OBSERVED.

RESISTORS IN OHMS (K = 1000 OHMS) AND CAPACITORS, CAPACITY IN MICROFARADS UNLESS OTHERWISE NOTED. RESISTOR CONTROLS INDICATE CLOCKWISE ROTATION.

CHASSIS No.120522-B

1. Voltages are positive DC, resistances in ohms, unless otherwise indicated.
2. All measurements taken with Voltmyst or equivalent.
3. All measurements taken between tube pin and chassis unless otherwise noted.
4. Voltage measurements made with:
 - a) Line voltage maintained at 115 volts AC.
 - b) Loudness control set for minimum volume (max CCW), all others set at mid-range.
 - c) No signal input (AM or FM) to tuner chassis.
 - d) No signal input to audio chassis.
 - e) SW-2 (on audio chassis) may be in any position.

NOTE: * TO SERVICE AUDIO CHASSIS WITHOUT REMOVING BALANCE CONTROL FROM CABINET, CONSTRUCT JUMPER PLUG AS OUTLINED BELOW. KEEP RESISTOR LEADS SHORT TO PREVENT HUM.

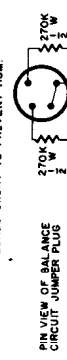

EMERSON RADIO AND PHONOGRAPH CORP.

Model 944B, using Audio Chassis 120522B and Tuner Chassis 120523B;
 Model 914B, using Tuner Chassis 120482B and Audio Chassis 120483B,
 are very similar to 944B covered on this and preceding page.

Gamble-Skogmo, Inc.

CORONADO MODEL RA 48-8182A

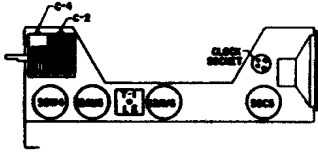

ALIGNMENT PROCEDURE CHART

STEP	CONNECT HIGH SIDE OF SIGNAL GENERATOR TO-	SET SIGNAL GENERATOR TO-	TURN RECEIVER DIAL TO-	ADJUST THE FOLLOWING FOR MAXIMUM OUTPUT. (KEEP SIGNAL FROM SIGNAL GENERATOR AS LOW AS POSSIBLE.)
1	ANTENNA SECTION TUNING CONDENSER IN SERIES WITH .1MFD COND.	455 KC.	FULL CLOCKWISE POSITION (CONDENSER PLATES FULLY OPEN)	BOTTOM & TOP OF T-1 IN SAME ORDER (IF TRANSFORMER)
2		1650 KC.		C4 (OSCILLATOR TRIMMER)
3	USE RADIATED SIGNAL	1500 KC.	MAXIMUM SIGNAL APPROX 1500 KC.	C2 (ANTENNA TRIMMER)
4				REPEAT STEPS 2 AND 3

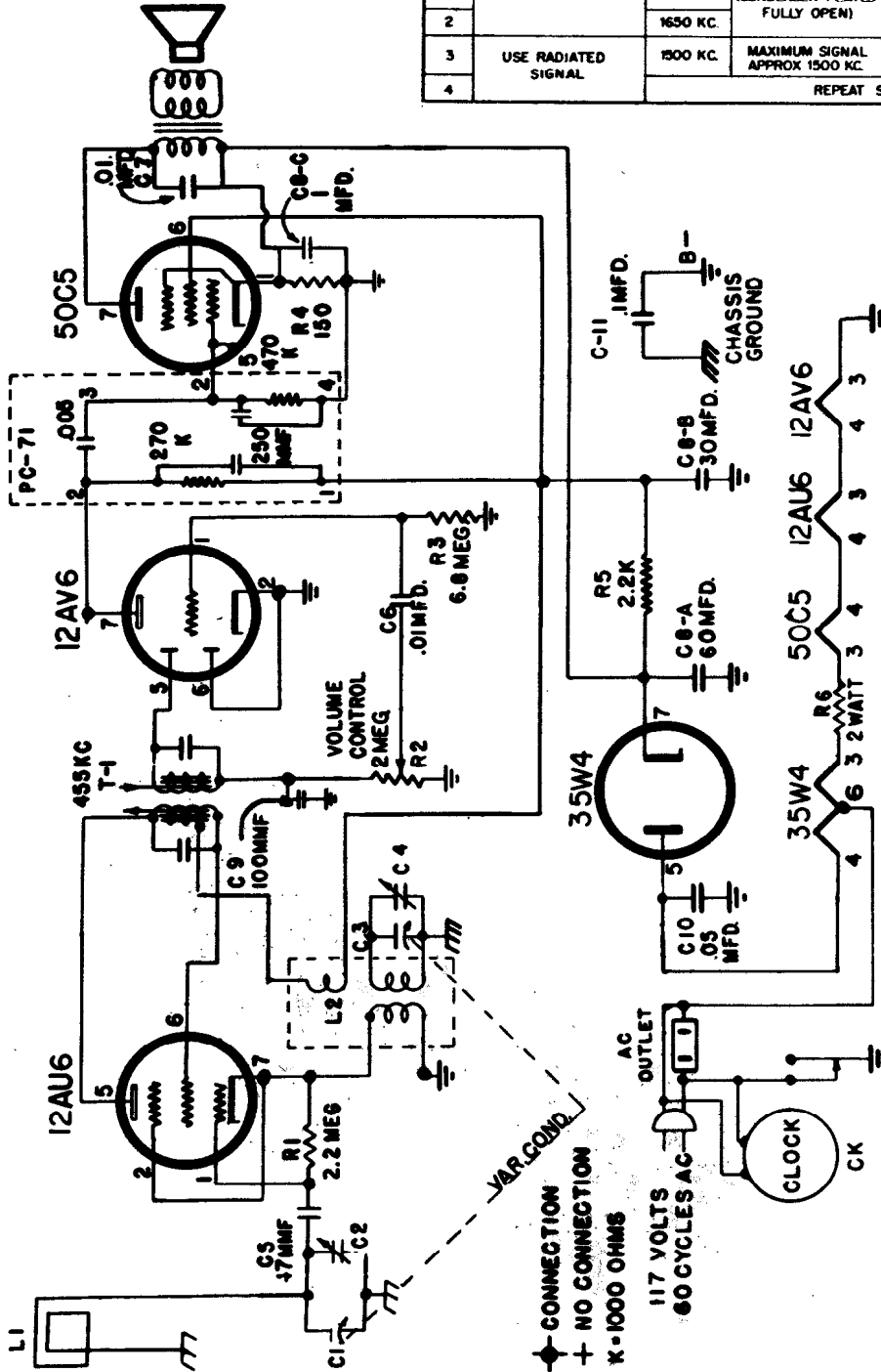

AS A MUSICAL WAKE-UP ALARM

1. Adjust the volume and tune the radio to the desired station you would like to hear in the morning.
2. Set the Red hand to the time you want to be awakened by gently moving the "Alarm and Time Set Knob" forward — toward front of cabinet.
3. Turn the Knob at hour 6 to "Auto" position. The radio is now set to be turned on automatically at the desired time.

ELECTRICAL SPECIFICATIONS

- Power Supply 117 Volts AC
- Frequency Range 540-1650 KC
- Intermediate Frequency 455 KC
- Sensitivity 3000 microvolts on loop for 50 MW output
- Selectivity 10 KC 2X at 455 KC
- Speaker 4" Alnico PM 3.2 Ohm voice coil
- Power Consumption 30 Watts
- Power Output 1.5 Watts, undistorted

VOLUME R-21, MOST-OFTEN-NEEDED

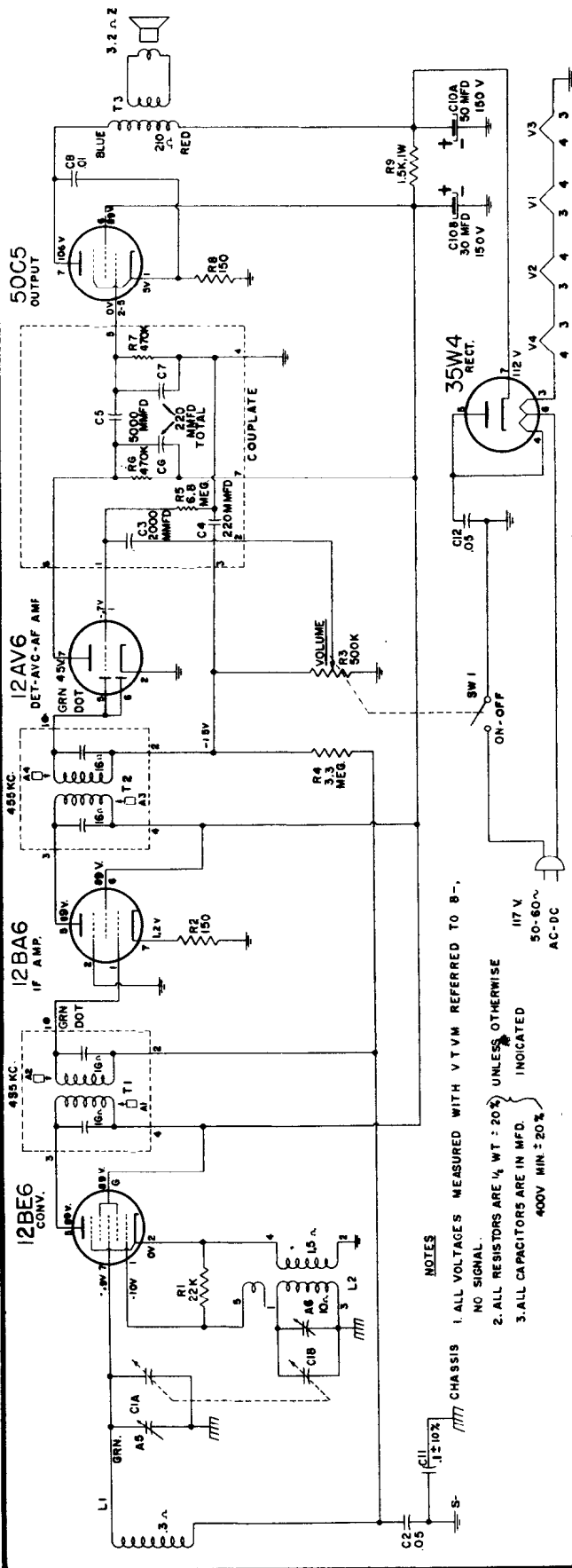

NOTES
 1. ALL VOLTAGES MEASURED WITH V T M REFERRED TO B-.
 NO SIGNAL.
 2. ALL RESISTORS ARE 1/4 WT ± 20% UNLESS OTHERWISE INDICATED
 3. ALL CAPACITORS ARE IN MFD. 400V MIN ± 20%
 117 V 50-60~ AC-DC

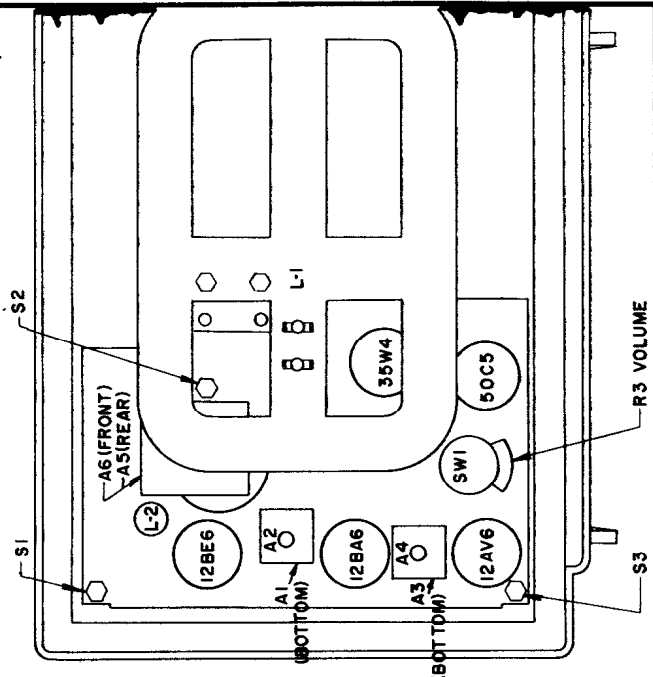

STEP	Set receiver dial to:	Adjust	Attach output of Signal Generator to:	Refer to Fig. 1 for location of alignment adjustments.
1.	Tuning gang fully open (Minimum capacity)	Use dummy antenna in series with output of signal generator consisting of: 455 KC .05 MFD Condenser 400V.	High side of signal generator to mixer grid. Ground lead of generator through .05 to chassis	Using a non-metallic alignment tool, adjust all the I.F. transformer cores for maximum output.
2.	Tuning gang fully open (Minimum capacity)	Loosely couple generator output to loop antenna. Bring a short length of insulated hook-up wire fashioned into a coil of a few turns close to the antenna loop and connect generator output to one end of this wire. Signal generator ground remains connected through .05 MFD condenser to chassis.		Adjust trimmer A6 for maximum output.
3.	1400 KC	Leave connected as above.		Adjust trimmer A5 for maximum output.

CAUTION: Be sure during RF alignment that the hand, or any objects on the bench, do not come in close contact with the antenna loop or detuning will occur and alignment will be incorrect. Wherever possible, RF alignment should be completed with chassis in its normal position in its cabinet.

Gamble-Shogmo.

CORONADO MODELS
 RA 50-8231 & RA 50-8232

GENERAL ELECTRIC

RADIO
MODEL
T-100A

Model T100A. (Model C403A is similar except for clock)

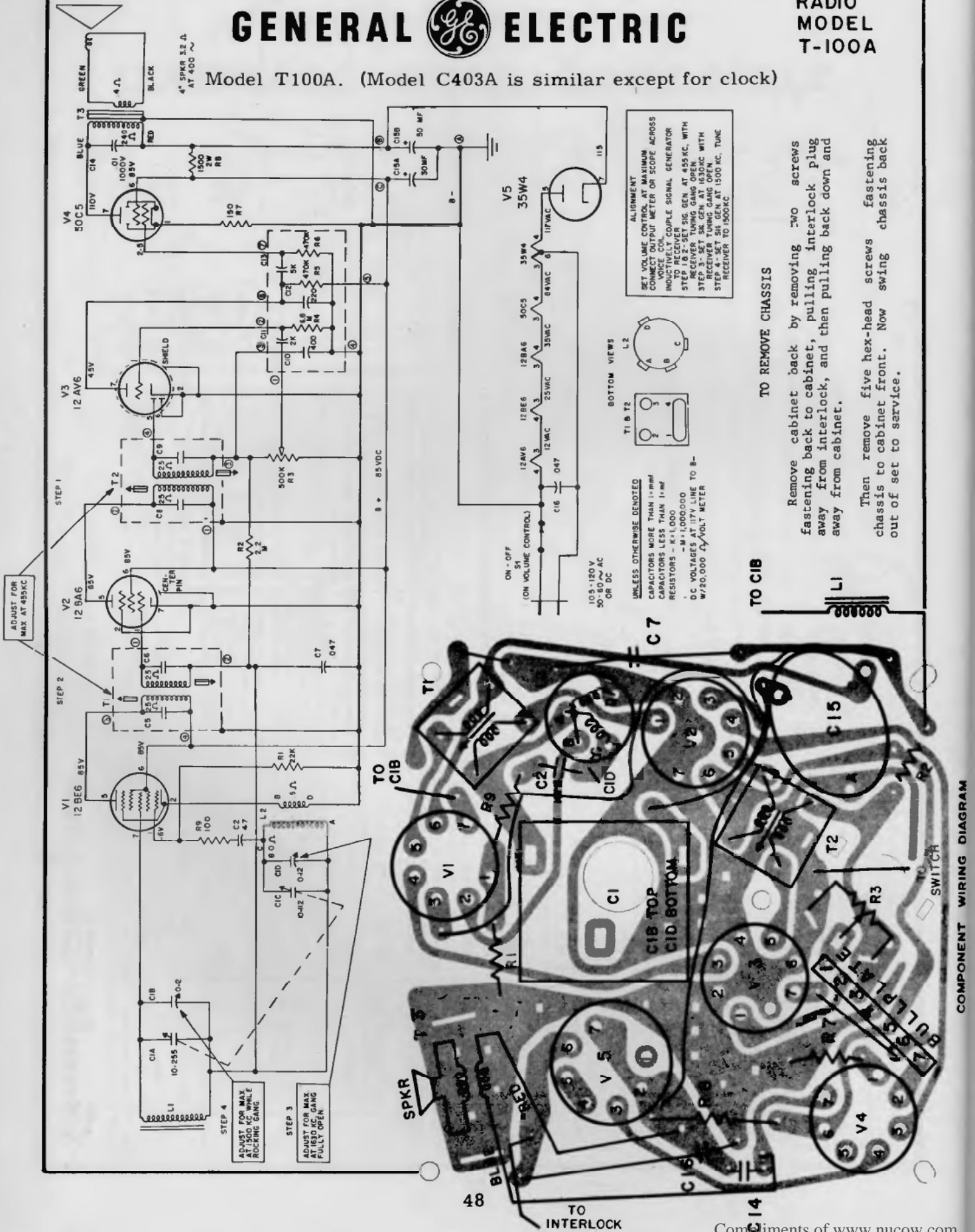

ALIGNMENT
SET VOLUME CONTROL AT MAXIMUM
CONNECT OUTPUT METER OR SCOPE ACROSS
INDUCTIVELY COUPLED SIGNAL GENERATOR
TO RECEIVER
STEP 1 - SET SIG. GEN. AT 455 KC. WITH
RECEIVER TUNING GANG OPEN
STEP 2 - SET SIG. GEN. AT 1500 KC. WITH
RECEIVER TUNING GANG OPEN
STEP 3 - SET SIG. GEN. AT 1500 KC. TUNE
RECEIVER TO 1500KC

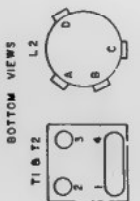

TO REMOVE CHASSIS

Remove cabinet back by removing two screws fastening back to cabinet, pulling interlock plug away from interlock, and then pulling back down and away from cabinet.

Then remove five hex-head screws fastening chassis to cabinet front. Now swing chassis back out of set to service.

UNLESS OTHERWISE DENOTED
CAPACITORS MORE THAN 1-MMF
CAPACITORS LESS THAN 1-MMF
RESISTORS - R-1,000
-R-10,000
-R-100,000
DC VOLTAGES - VOLTAGE TO B-
W/10,000 Ω VOLT METER

COMPONENT WIRING DIAGRAM

GENERAL ELECTRIC

Radio Models T145A, T146A

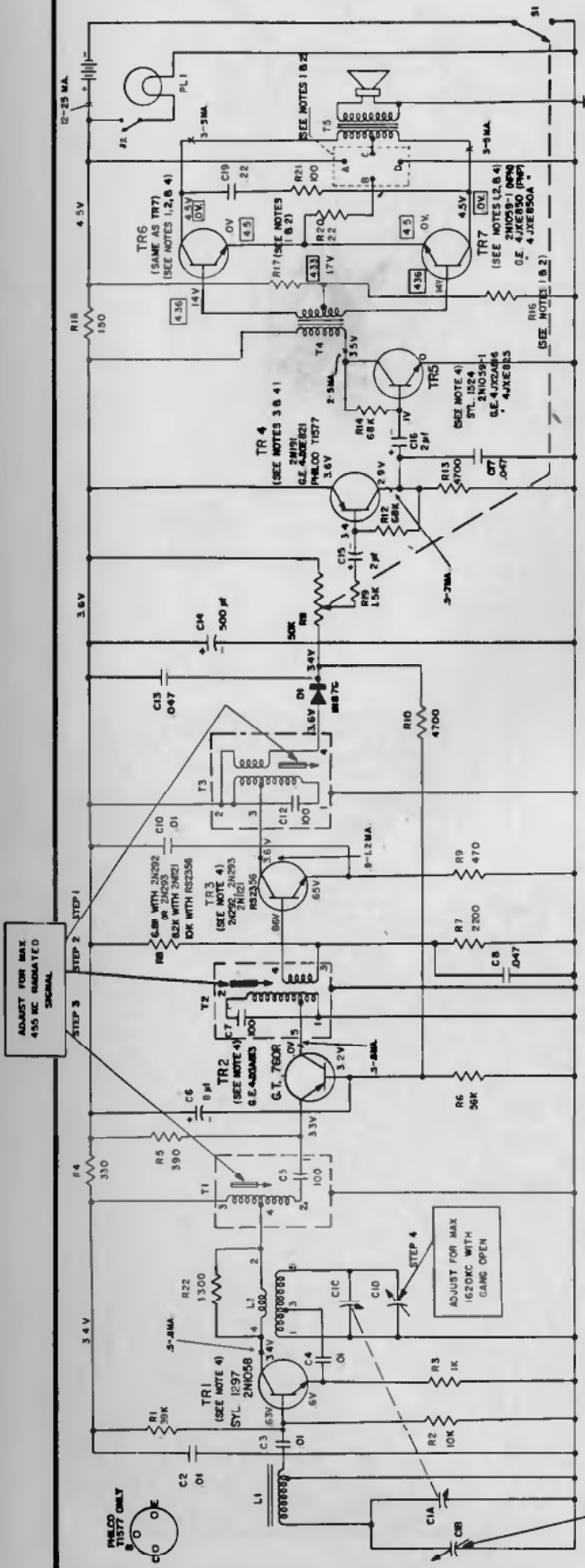

CAPACITORS

- C1 -- Tuning Cap.
- C2 -- .01mf.
- C3 -- .01mf.
- C4 -- .01mf.
- C6 -- 8mf.
- C8 -- .047mf.
- C10 -- .01mf.
- C13 -- .047mf.
- C14 -- 500mf.
- C15 -- 2mf.
- C16 -- 2mf.
- C17 -- .047mf.
- C19 -- .22mf.

RESISTORS

- R1 -- 39K
- R2 -- 10K
- R3 -- 1K
- R4 -- 330
- R5 -- 390
- R6 -- 56K
- R7 -- 2.2K
- R8 -- 6.8K, 8.2K, or 10K
- R9 -- 470
- R10 -- 4.7K
- R11 -- 50K
- R12 -- 68K
- R13 -- 4.7K
- R14 -- 68K
- R16 -- (See Notes)
- R17 -- (See Notes)
- R18 -- 150
- R19 -- 1.5K
- R20 -- 2.2K
- R21 -- 100
- R22 -- 3.3K

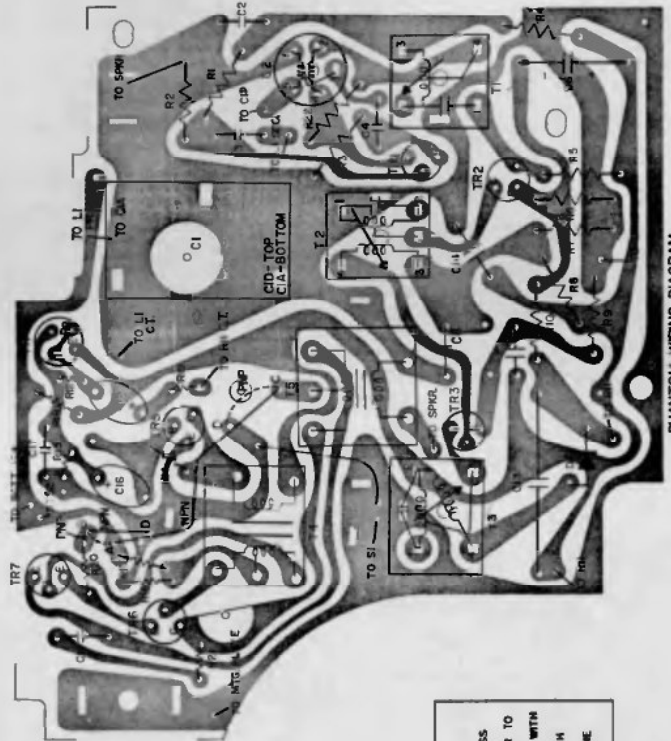

PHANTOM WIRING DIAGRAM

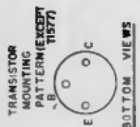

- NOTES**
1. FOR MPN TR6 & TR7
 - A. CONNECT A JUMPER WIRE BETWEEN POINTS B & D. (SEE PHANTOM WIRING DIAGRAM)
 - B. R6 MUST BE 50 OHMS
 - C. R7 MUST BE 1K.
 2. FOR PNP TR6 & TR7
 - A. CONNECT A JUMPER WIRE BETWEEN POINTS A & B. (SEE PHANTOM WIRING DIAGRAM)
 - B. R6 MUST BE 1K
 - C. R7 MUST BE 50 OHMS
 3. T577 (PHILCO) TRANSISTOR BASE LEAD MUST BE SOLDERED INTO B2 AS SHOWN ON PHANTOM WIRING DIAGRAM BASE LEAD OF ALL OTHER RECOMMENDED TRANSISTORS FOR TR4 MUST BE SOLDERED INTO B1.
 4. REPLACE WITH TRANSISTOR TYPES SHOWN.

ALIGNMENT

SET VOLUME CONTROL AT MAXIMUM
CONNECT OUTPUT METER ON SCOPE ACROSS
INDUCTIVELY COUPLE SIGNAL GENERATOR TO
RECEIVER TUNING GANG OPEN 1620 KC. WITH
STEP 1, 2, 3. SET SIG. GEN. AT 455 KC. WITH
STEP 4. TUNE TUNING GANG OPEN 1620 KC. WITH
STEP 5. SET SIG. GEN. AT 1400 KC. TUNE
RECEIVER TO 1400 KC.

UNLESS OTHERWISE NOTED—
CAPACITORS MORE THAN 1-MHF
RESISTORS LESS THAN 1-MF
RESISTORS ARE 1/2 WATT

6. VOLTAGES ARE POSITIVE WITH
RESPECT TO GROUND UNLESS OTHERWISE
NOTED

7. VOLTAGES SHOWN IN ARE
WITH TR6 & TR7 PNP.

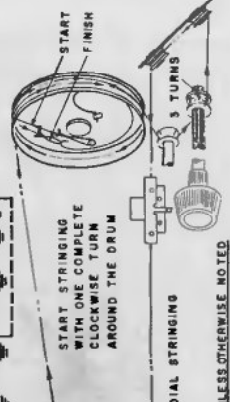
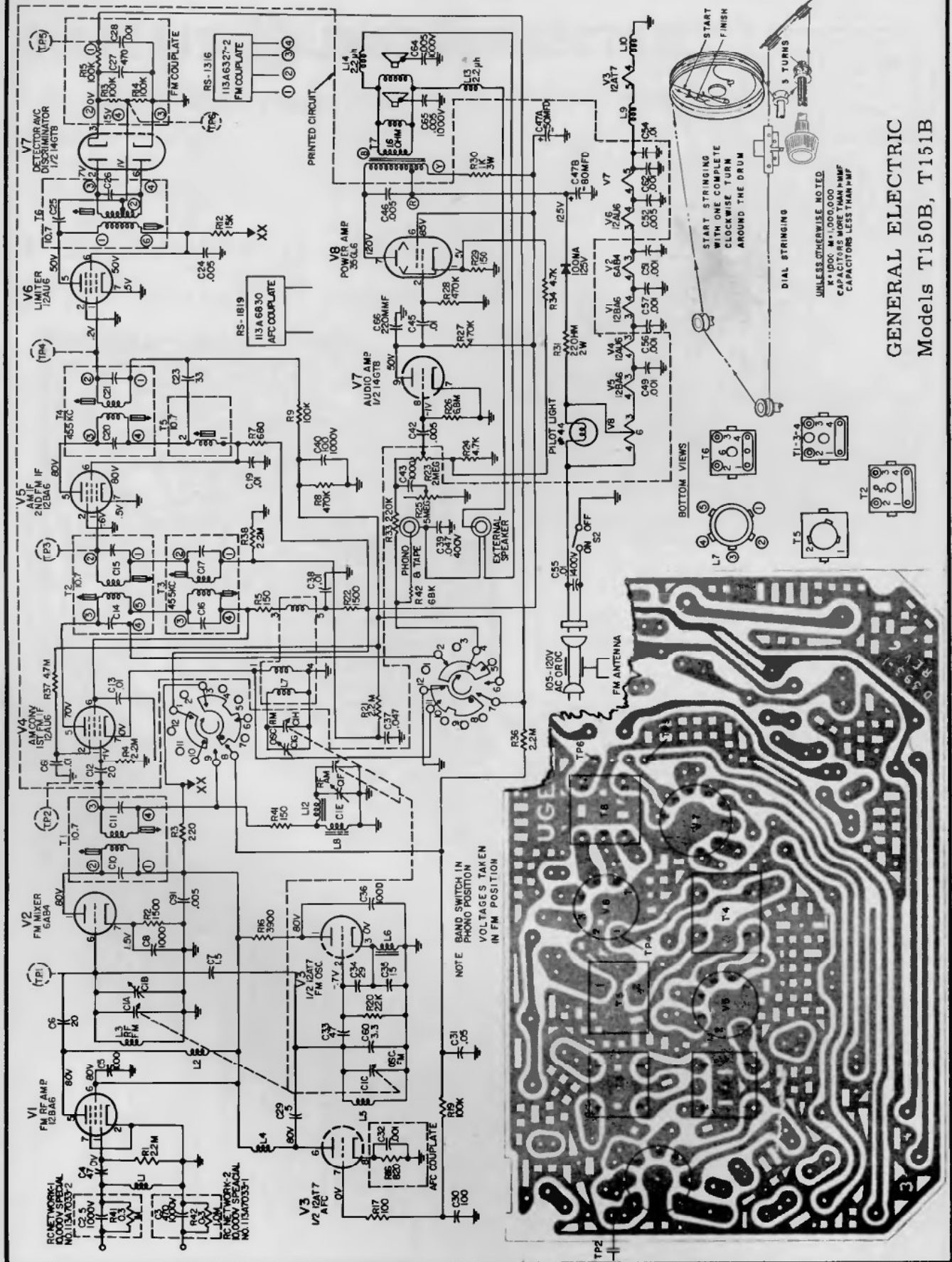

GENERAL ELECTRIC
 Models T150B, T151B

GENERAL ELECTRIC

MODELS T165A, T166A

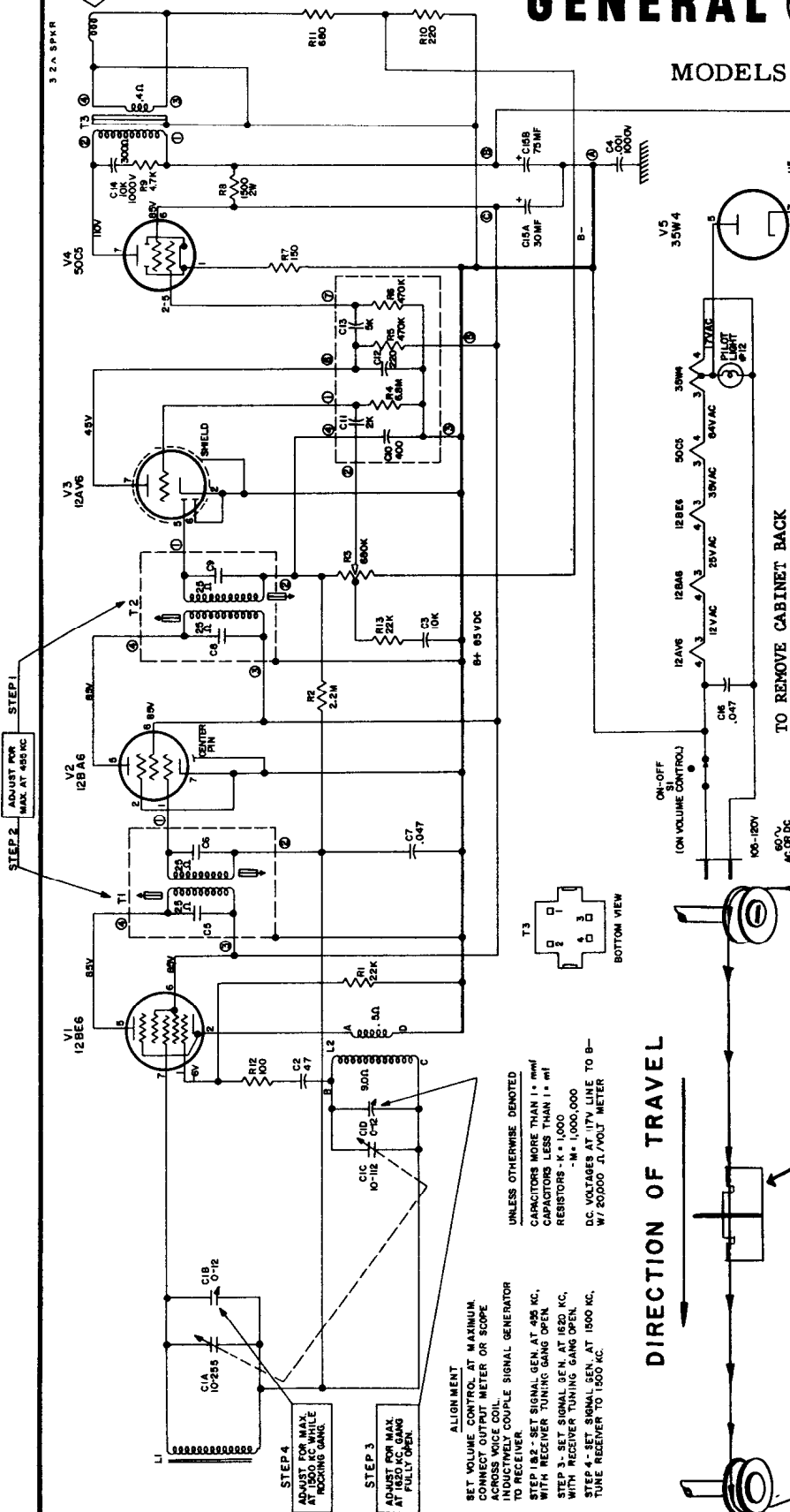

TO REMOVE CABINET BACK

Four hex-head screws fasten the cabinet back to the cabinet front. Two are located in the recessed hand-grip, and two on the lower rear edge of the cabinet. Remove these screws and pull out the interlock plug to remove the back.

TO REMOVE CHASSIS

Four hex-head screws fasten the cabinet back to cabinet bottom, two fasten the volume control to the cabinet front, and one fastens the antenna bracket to the cabinet front. Remove these screws and the volume control knob.
 The dial drum is captive and remains on the cabinet front. The tuning gang shaft will slide out of the dial drum when the chassis is pulled out of the cabinet.
 When replacing the chassis, be sure to line the flat side of the gang shaft up with the flat side of the dial drum hole. This will allow the gang shaft to enter the dial drum.

DIRECTION OF TRAVEL

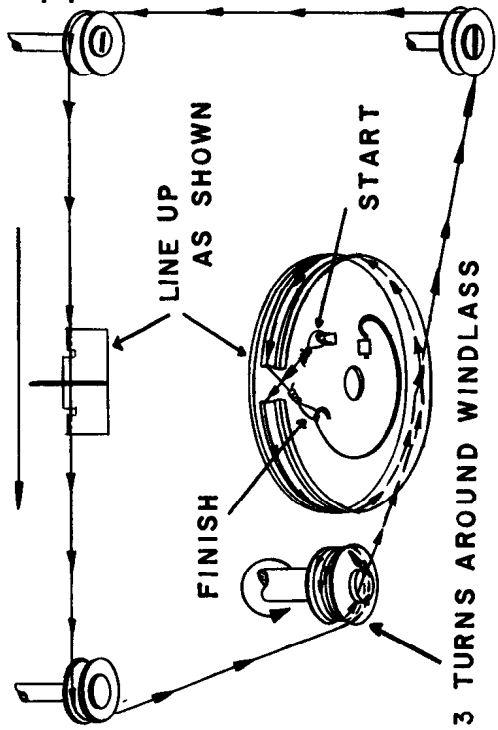

STRINGING DIAGRAM

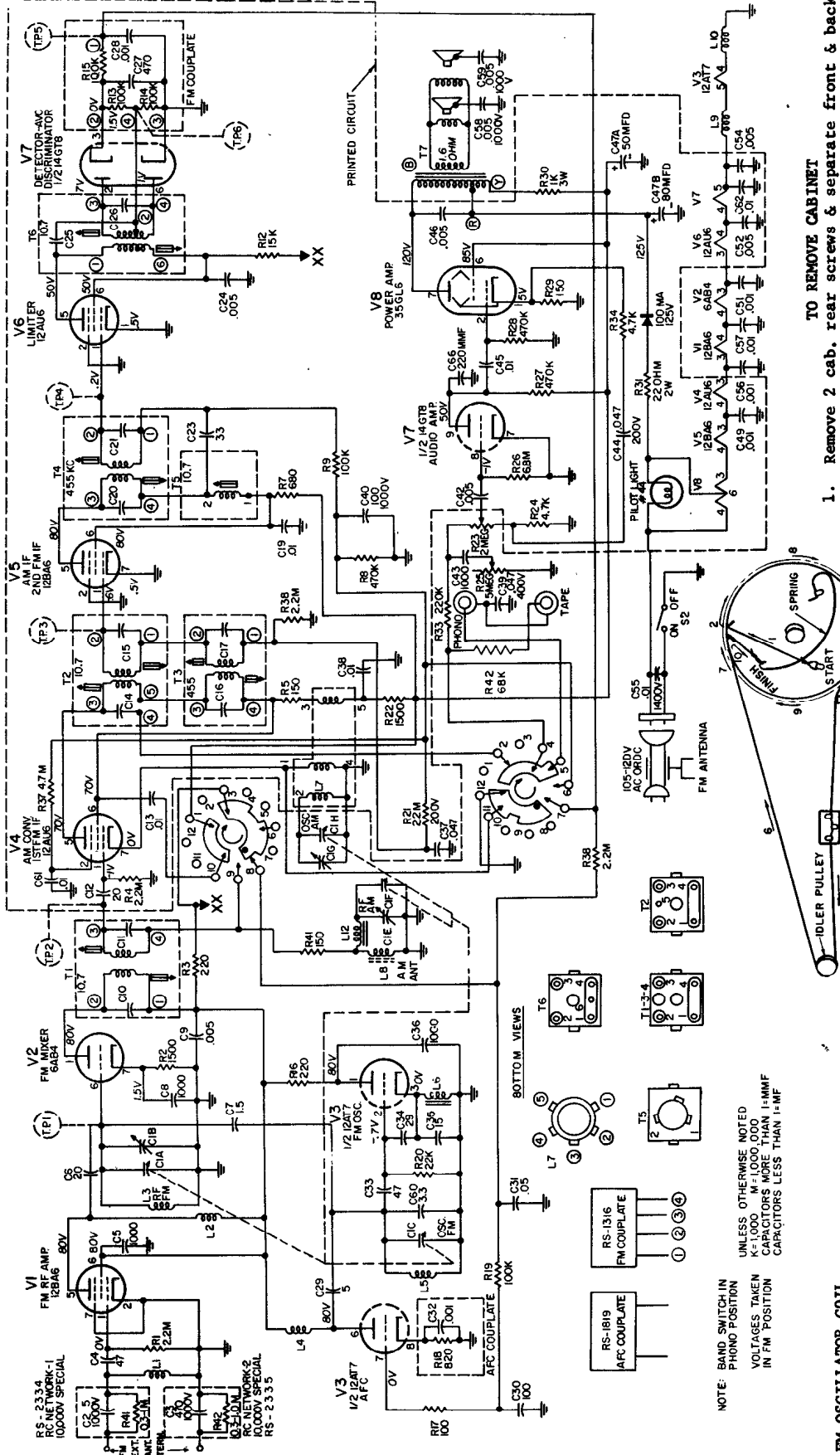

- TO REMOVE CABINET**
1. Remove 2 cab. rear screws & separate front & back.
 2. Chassis can remain on cabinet front for troubleshooting and alignment.
(Knobs are removed by releasing captive clips with a screwdriver.)
- TO REMOVE A SPEAKER**
1. Same as No. 1 above.
 2. Unscrew the six hex-head screws holding the grille to the cabinet front.
 3. Label and unsolder speaker leads from speaker terminals. Reversed speaker leads will cause distorted audio.
 4. Unscrew the four screws around front of speaker and remove the speaker from cabinet front.

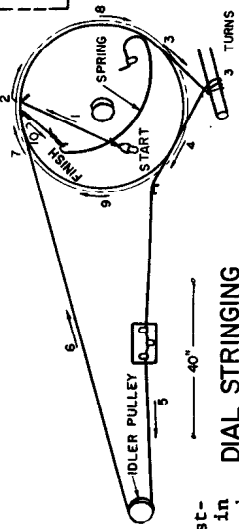

DIAL STRINGING

GENERAL ELECTRIC
Model T210B

FM OSCILLATOR COIL

The FM oscillator coil, L5, may require adjustment if components, other than tubes, are changed in the FM oscillator-mixer section. Check the band end frequencies. If the set tunes through 108 and 88 MC do not touch the coil. If the oscillator frequency is low, adjust L5 by spreading the turns slightly. (This raises the dial frequency.) If the oscillator frequency is high, adjust L5 by squeezing the turns together slightly. (This lowers the dial frequency.)

NOTE: A small change in the space between 2 turns of L5 shifts the frequency approximately 1 MC.

NOTE: BAND SWITCH IN PHONO POSITION
VOLTAGES TAKEN IN FM POSITION
UNLESS OTHERWISE NOTED
K=1000 M=1000,000
CAPACITORS MORE THAN 1-MMF
CAPACITORS LESS THAN 1-MMF

VOLUME R-21, MOST-OFTEN-NEEDED 1961 RADIO SERVICING INFORMATION

GENERAL ELECTRIC Models P790A, B, P791A, B

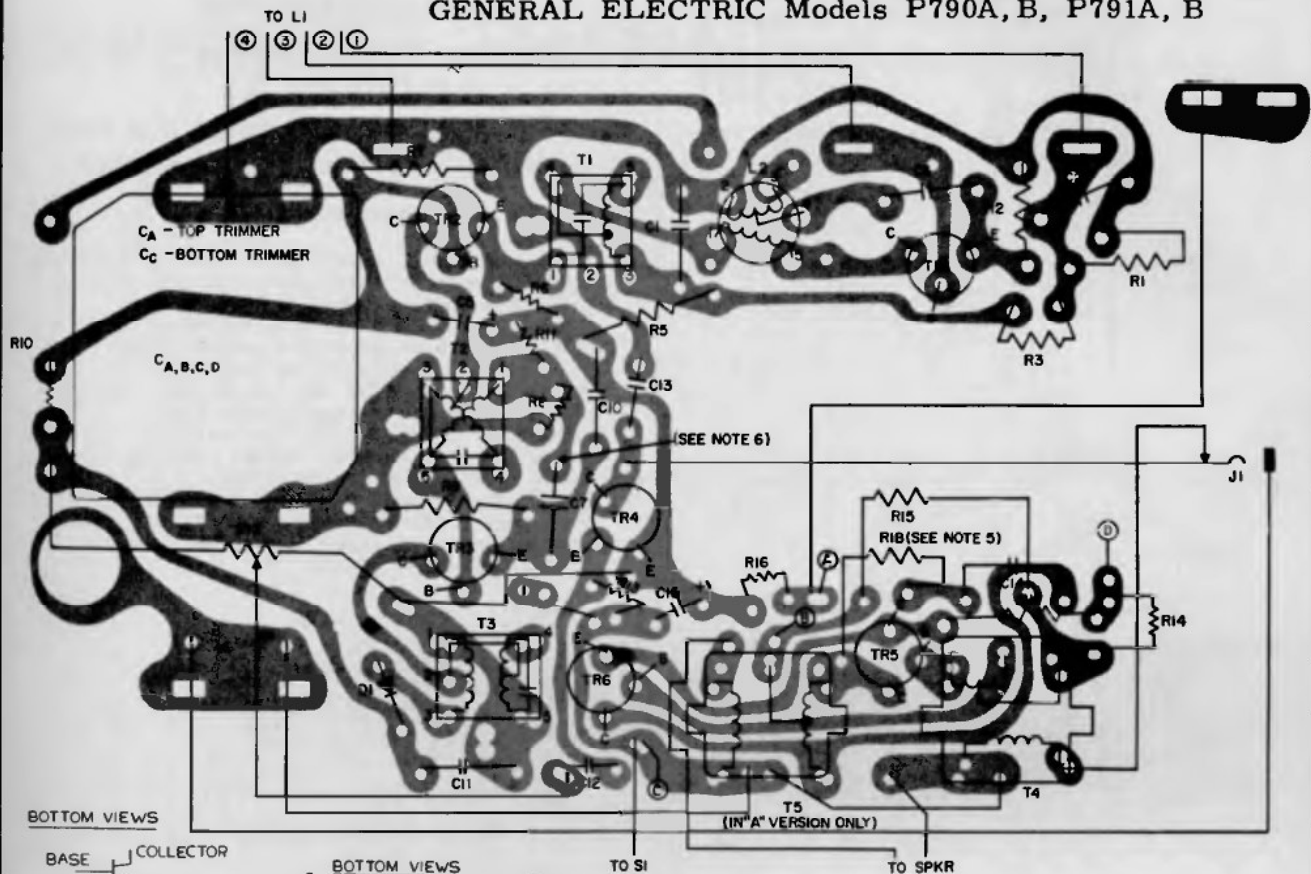

BOTTOM VIEWS

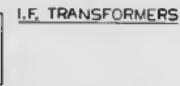
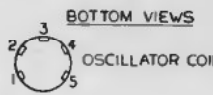
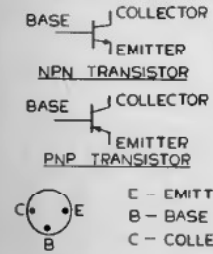

NOTES.

1. UNLESS OTHERWISE NOTED: CAPACITORS MORE THAN 1=MMF CAPACITORS LESS THAN 1=MF RESISTORS ARE 1/2 WATT ±K=1000
2. VOLTAGE & CURRENT READINGS ARE AVERAGE UNDER NO SIGNAL CONDITIONS. VOLTAGES ARE POSITIVE WITH RESPECT TO GROUND.
3. SIMILAR APPROVED TRANSISTORS MAY BE USED.
4. VOLTAGES SHOWN IN ○ ARE FOR PNP TRANSISTORS IN TR5 & TR6.
5. C14=0.02MFD, R18 IS REPLACED BY JUMPER WITH DYNAMIC SPEAKER. C14=1MFD, R18 IS 1K WITH MAGNETIC SPEAKER.
6. IF TR3 IS 2N293 OR 2N292, C7 GOES TO GROUND.
7. FOR NPN TRANSISTORS IN TR5 & TR6 A. JUMPER A TO B B. JUMPER C TO D
8. FOR PNP TRANSISTORS IN TR5 & TR6 A. JUMPER A TO D B. JUMPER B TO C
9. RESISTANCE ACROSS OUTPUT TRANSFORMER IS 45Ω WITH DYNAMIC SPEAKER. READING WITH MAGNETIC SPEAKER IS 85Ω.

ADJUST FOR MAX. AT 1400 KC WHILE ROCKING GANG STEP 5

ADJUST FOR MAX. AT 580KC WHILE ROCKING GANG STEP 6

PEAK AT 455KC STEP 3 STEP 2 STEP 1

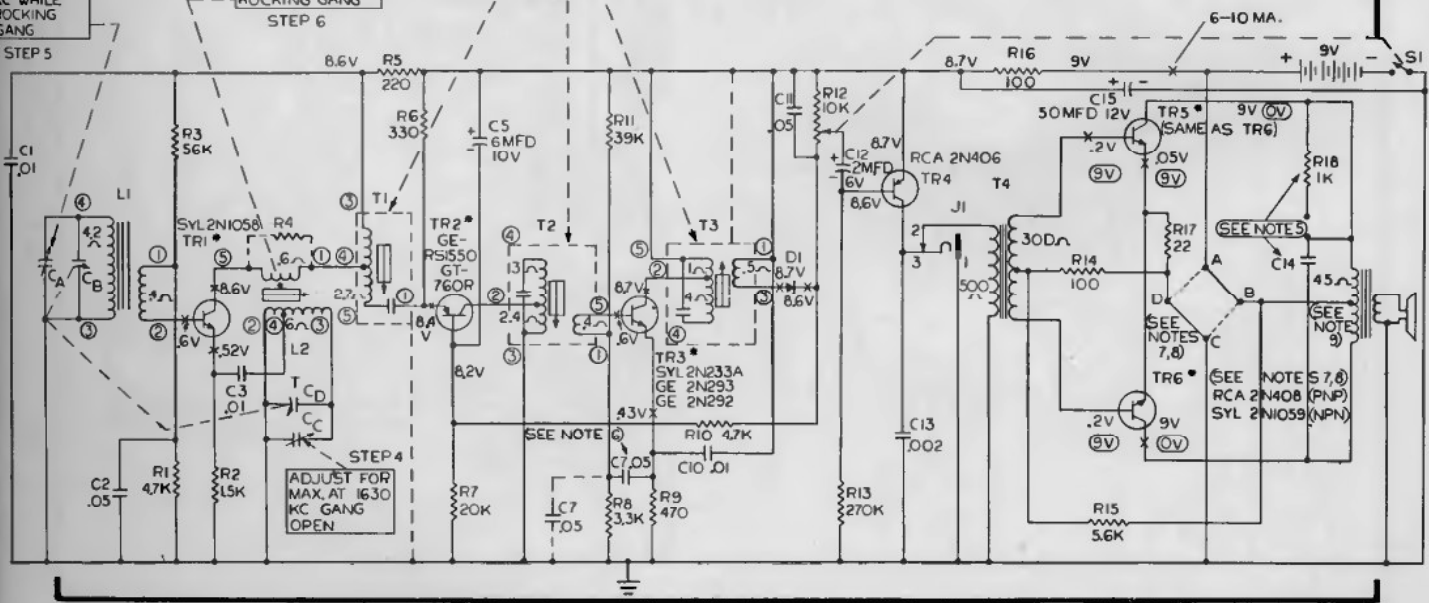

GENERAL ELECTRIC

Models P805A, P806A, P807A, B, and P808A, B

"A" version diagrams on this page, and "B" version on the next page.

TO REMOVE CIRCUIT BOARD

1. Turn screw in cabinet back counterclockwise until it becomes loose (this a captive screw and remains in the cabinet).
2. Insert a coin in either slot on the cabinet bottom and twist to remove the cabinet back.
3. Remove screw holding tuning dial.
4. Remove 3 screws under the tuning dial to release the tuning gang from the cabinet front.
5. Remove one 11/32" nut (bottom center of circuit board) and 3 hexhead screws holding circuit board to bosses on cabinet front.
6. Fold tuning gang and circuit board out of cabinet front toward the volume control end. It is not necessary to remove the volume control to repair the circuit board.

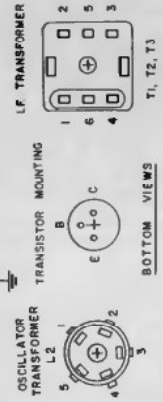
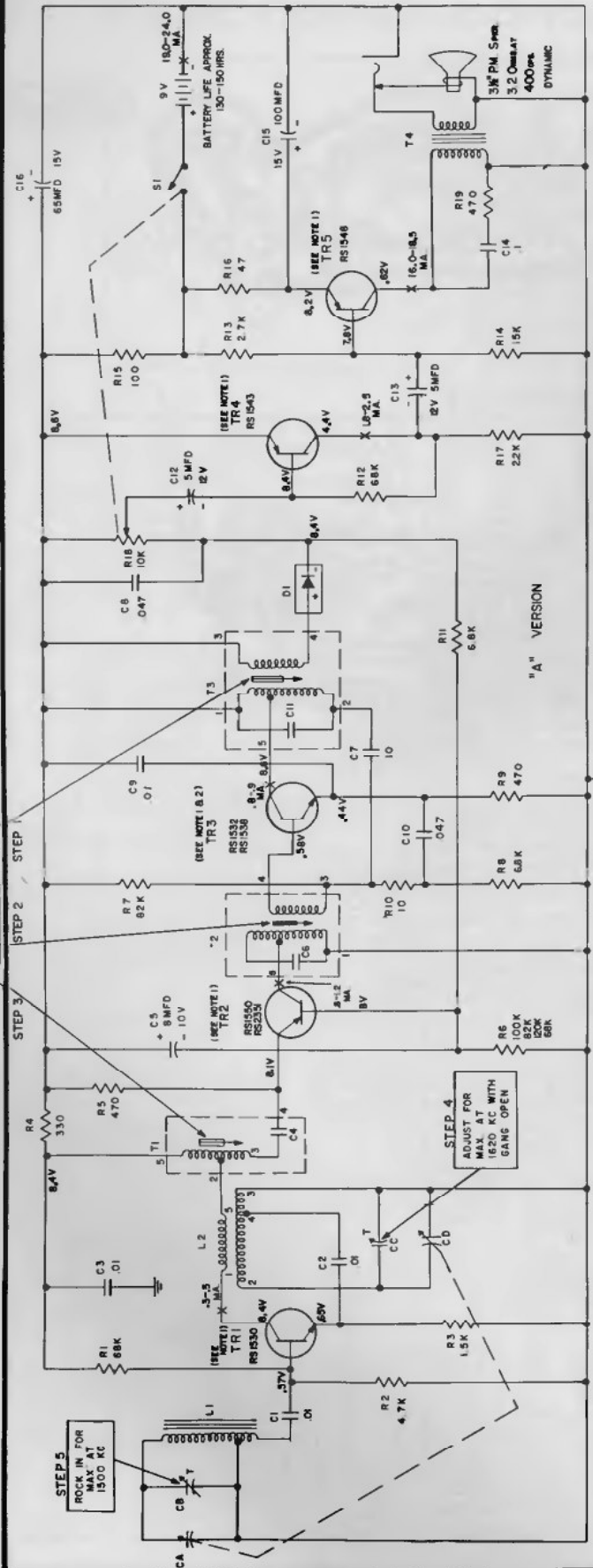

ALIGNMENT
SET VOLUME CONTROL AT MAXIMUM
CONNECT OUTPUT METER OR SCOPE
ACROSS VOICE COIL
INDUCTIVELY COUPLE SIGNAL GENERATOR
TO RECEIVER.

UNLESS OTHERWISE NOTED -
CAPACITORS MORE THAN 10MMF
CAPACITORS LESS THAN 10MMF
RESISTORS ARE 1/2 WATT K = 1000

NOTE 1 -
REPLACE WITH TRANSISTOR
TYPES SHOWN.
2 -
WHEN TR3 IS 2N169
R7 = 47K
C7 IS DELETED
R7 REPLACED BY JUMPER

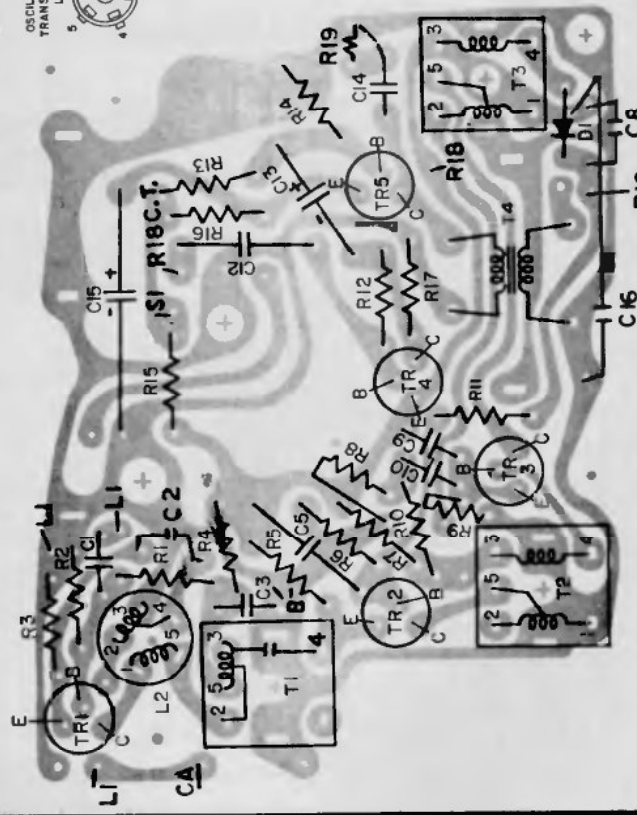

LATE PRODUCTION

GENERAL ELECTRIC

Radio Models P807B and P808B
(See preceding page for A version)

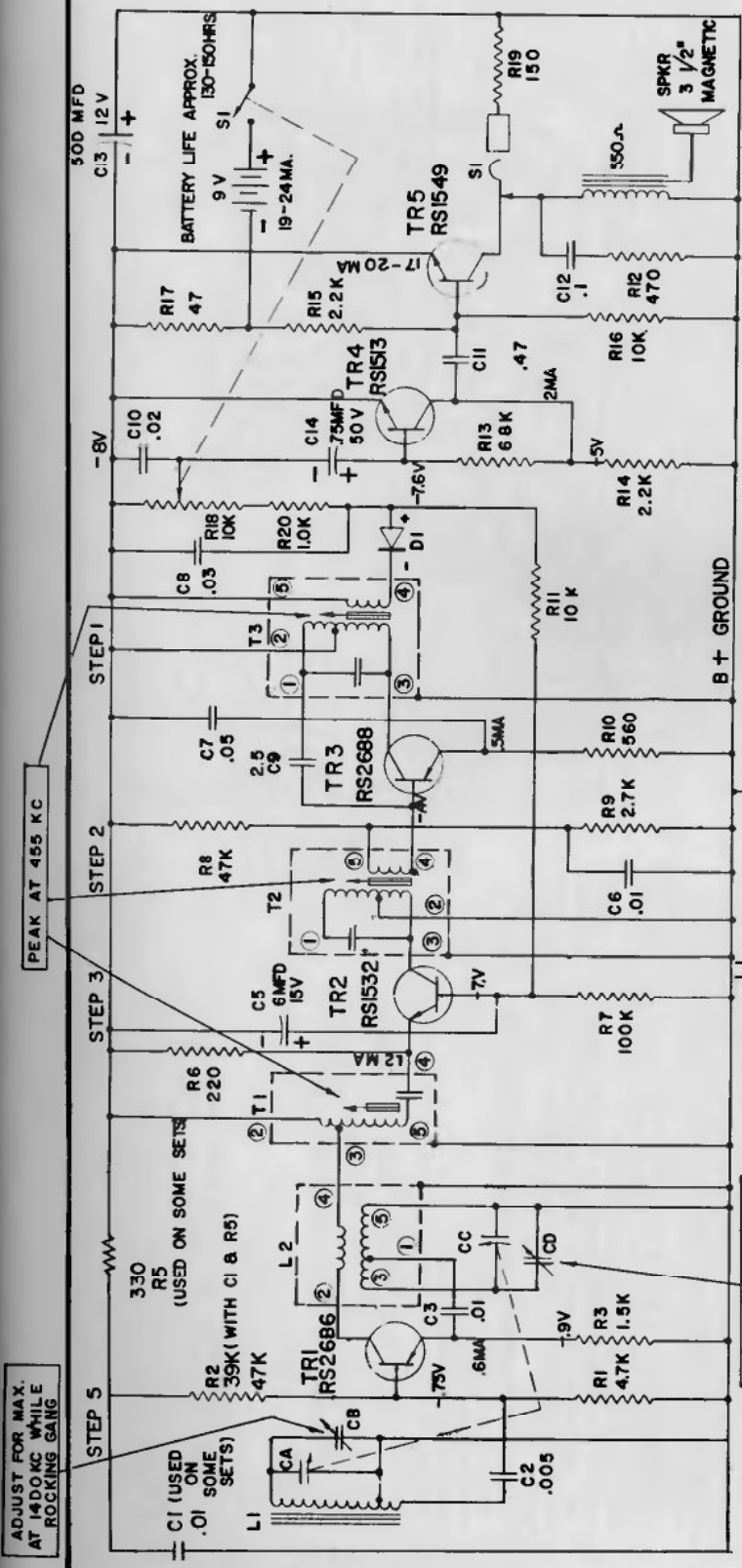

BOTTOM VIEWS

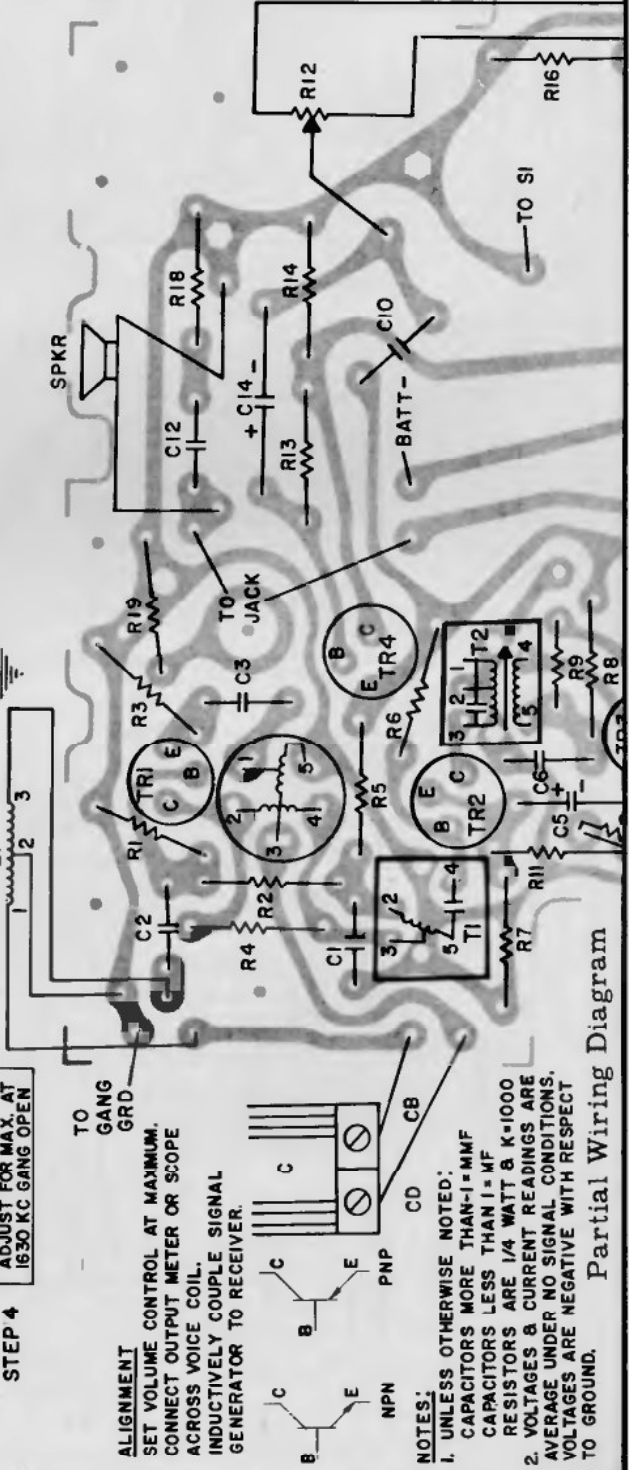
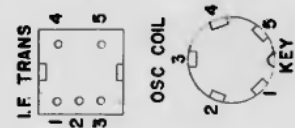

ALIGNMENT
SET VOLUME CONTROL AT MAXIMUM.
CONNECT OUTPUT METER OR SCOPE
ACROSS VOICE COIL.
INDUCTIVELY COUPLE SIGNAL
GENERATOR TO RECEIVER.

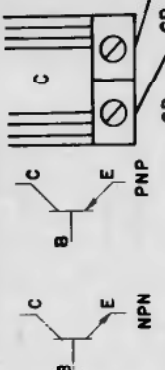

- NOTES:**
- UNLESS OTHERWISE NOTED:
CAPACITORS MORE THAN 1 = MMF
CAPACITORS LESS THAN 1 = MF
RESISTORS ARE 1/4 WATT & K=1000
AVERAGE UNDER NO SIGNAL CONDITIONS.
VOLTAGES ARE NEGATIVE WITH RESPECT
TO GROUND.

Partial Wiring Diagram

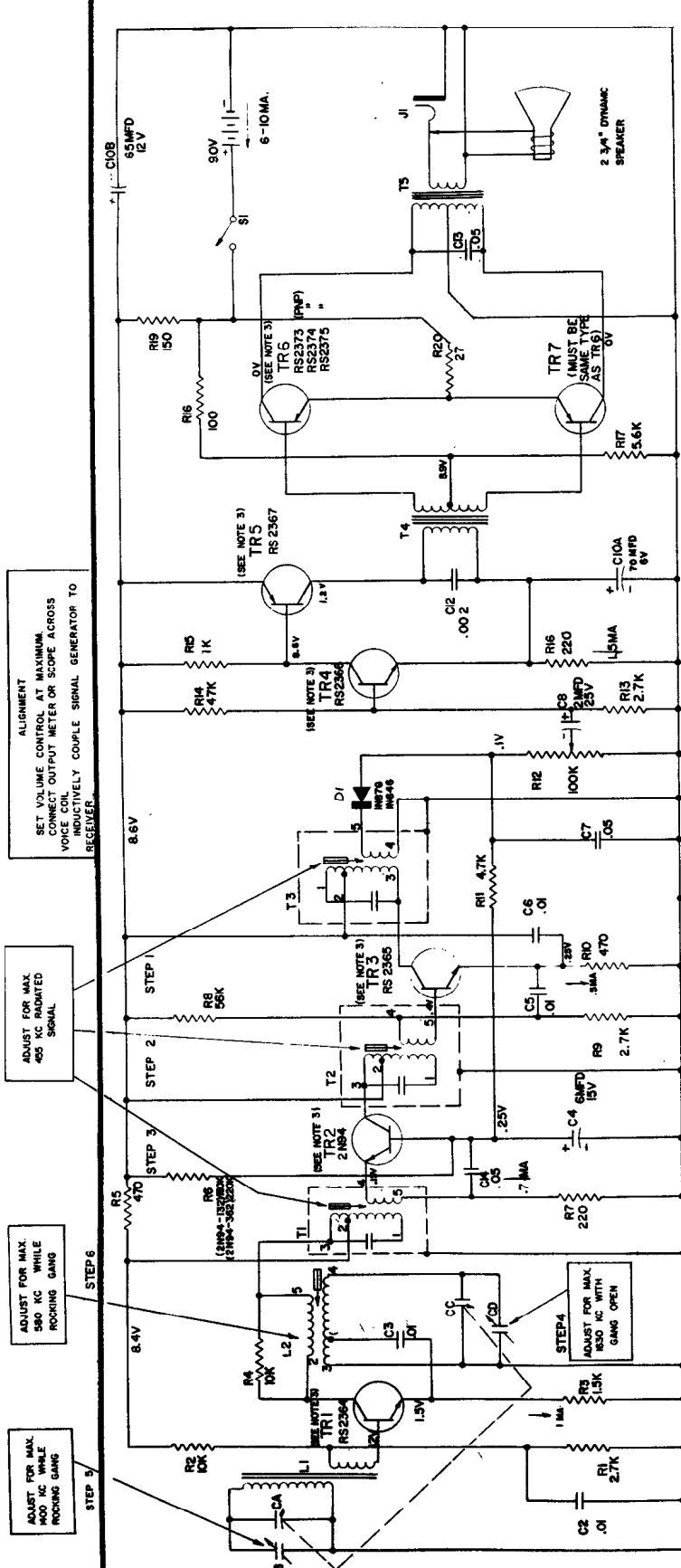

ALIGNMENT
SET VOLUME CONTROL AT MAXIMUM.
CONNECT OUTPUT METER OR SCOPE A CROSS
VOICE COIL
INDUCTIVELY COUPLE SIGNAL GENERATOR TO
REGENERATOR.

ADJUST FOR MAX.
400 KC RADIATED
SIGNAL

ADJUST FOR MAX.
580 KC WHILE
ROCKING GANG

ADJUST FOR MAX.
1500 KC WHILE
ROCKING GANG

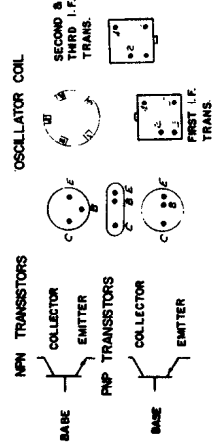

BOTTOM VIEWS

NOTES—
1- UNLESS OTHERWISE NOTED—
CAPACITORS MORE THAN 1- MUF
TRANSISTORS LESS THAN 1- MUF
RESISTORS ARE 1/2 WATT
K=1000
2- VOLTAGES ARE POSITIVE WITH
RESPECT TO GROUND UNDER NO
SIGNAL CONDITIONS.
3- REPLACE WITH TRANSISTOR TYPES SHOWN, OR
ORDER BY CATALOG NUMBER AS LISTED IN PARTS
LIST.

in series with the battery (-) and pivoted connec-
tor. If an excessive total current drain is recorded,
the individual collector currents of each transistor
should be checked. An excessive current reading may
mean a shorted transistor; no current will indicate
that a transistor or associated circuit component
is defective.

- TO REMOVE CHASSIS
1. Disengage screw on rear of cabinet.
 2. Insert coin in slot on bottom of cabinet and twist to remove cabinet back.
 3. Remove 5 screws holding board to cabinet bosses. (Do not remove screws from antenna holder.)
 4. Swing circuit board up 90° from cabinet front.
- TO REMOVE VOLUME CONTROL AND/OR TUNING CAPACITOR
1. Remove chassis.
 2. Remove volume control knob.
 3. Remove two screws holding tuning capacitor mounting plate to cabinet front.
 4. Unscrew metal stud holding mounting bracket near speaker and dial scale opening.
 5. Carefully lift out chassis and controls, tilt unit slightly to slide dial pointer out of opening.

- NO RECEPTION:
1. Check battery voltage and battery contacts.
 2. Check on-off switch.
 3. Check all antenna lead connections.
 4. Check coil L2.
- WEAK AUDIO:
1. Check battery voltage for 9 volts.
 2. Check battery current.
 3. Check transistor collector currents.
 4. Check alignment.
- INTERMITTENT:
1. Check battery contacts for corrosion.
 2. Check solder connections on dip-soldered side of circuit board.
- Intermittent audio, motorboating, and poor reception is frequently caused by poor battery contact or low battery voltage.

TROUBLESHOOTING

A check of battery condition and total current drain of the receiver should be made first. All current measurements are made at quiescence with the receiver turned on, volume control at minimum, tuning gang closed, and with no-signal conditions. The total receiver current drain is 6 to 10 mills. This is measured by inserting a milliammeter

GENERAL ELECTRIC
Models P815A, P816A

GENERAL ELECTRIC

MODELS P830C and P831C

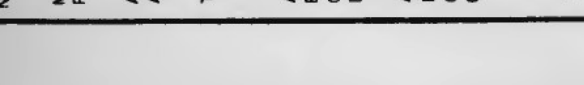
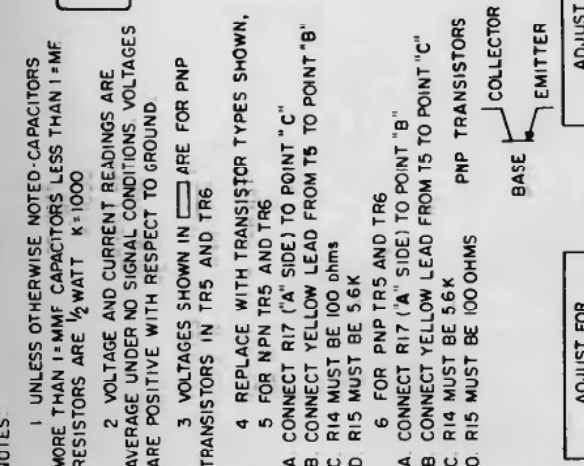
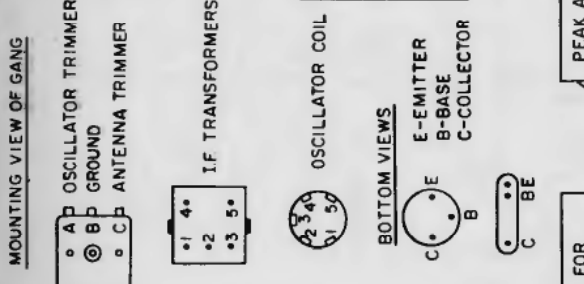
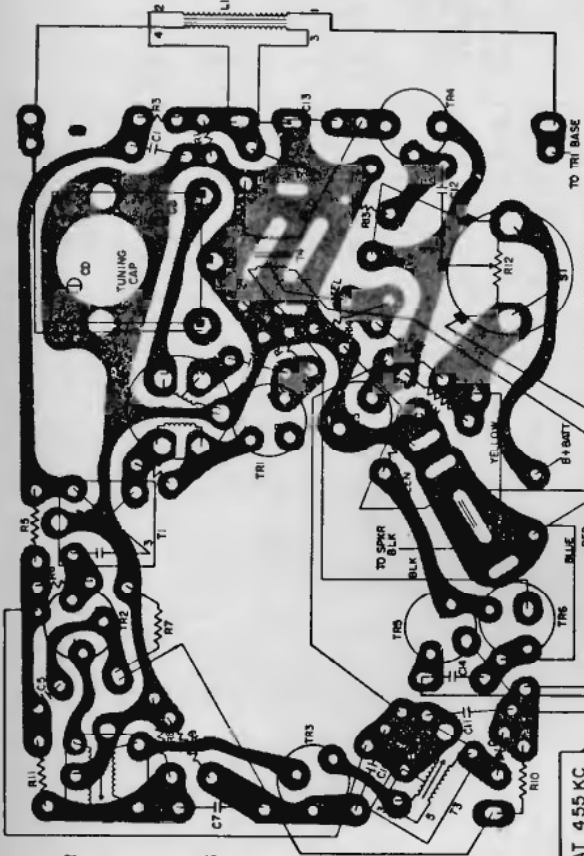

GENERAL ELECTRIC

MODELS
P830E
P831E

TO REMOVE CIRCUIT BOARD

1. Remove cabinet back.
2. Remove screw that is mounted next to volume control.
3. Place fingernail under phone jack and lift chassis up, then slide slightly in direction of cabinet bottom.

When replacing chassis, carefully tilt chassis so that tuning knob fits into knob opening, then slide chassis up towards cabinet top. Chassis mounting screw hole must line up with hole in mounting boss on cabinet.

TO REMOVE VOLUME CONTROL

1. Remove tuning knob.
 2. Remove two screws mounted under tuning knob.
 3. Remove control.
- IMPORTANT:** After installing volume control, be sure there is continuity between mounting screw head and conductor pattern for each screw.

TO REMOVE TUNING CAPACITOR

1. Remove pulley from gang shaft.
2. Remove two mounting screws.
3. Unsolder the three gang connection lugs on dip-solder side of board.

IF TRANSFORMERS

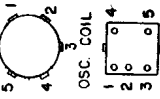

NOTES:

1. UNLESS OTHERWISE NOTED - CAPACITORS MORE THAN 1-μfd CAPACITORS LESS THAN 1-μfd RESISTORS ARE 1/2 WATT & K-1000 VOLTAGES & CURRENT READINGS ARE AVERAGE UNDER NO SIGNAL CONDITIONS VOLTAGES ARE NEGATIVE WITH RESPECT TO GROUND.
3. REPLACE WITH TRANSISTOR TYPES SHOWN.
4. FOR NPN TRANSISTORS IN TR5 & TR6 (a) JUMPER C TO D (b) JUMPER A TO B FOR PNP TRANSISTORS IN TR5 & TR6 (a) JUMPER A TO D (b) JUMPER C TO B

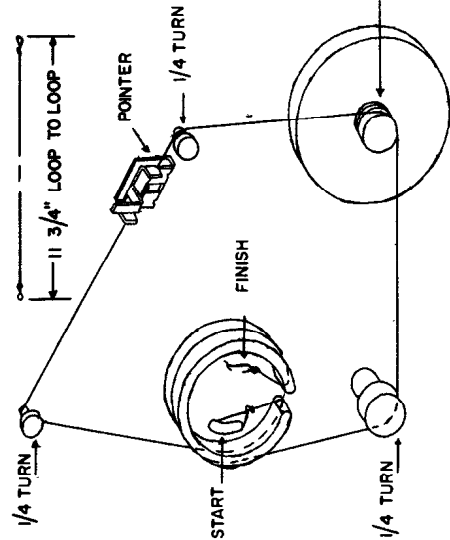

START STRINGING AT GANG DRUM AS INDICATED WITH GANG IN OPEN POSITION & POINTER AT THE RIGHT.

STEP 5
ADJUST FOR MAX. AT 1400 KC WHILE ROCKING GANG

STEP 6
ADJUST FOR MAX. AT 580 KC WHILE ROCKING GANG

STEP 1 8.4 V

STEP 2

STEP 3

STEP 4

STEP 5

STEP 6

PEAK AT 455 KC

8.0 V

3.0 V

1.4 V

.2 V

.3 V

.2 V

.15 V

.05 V

.15 V

.15 V

.15 V

.15 V

.15 V

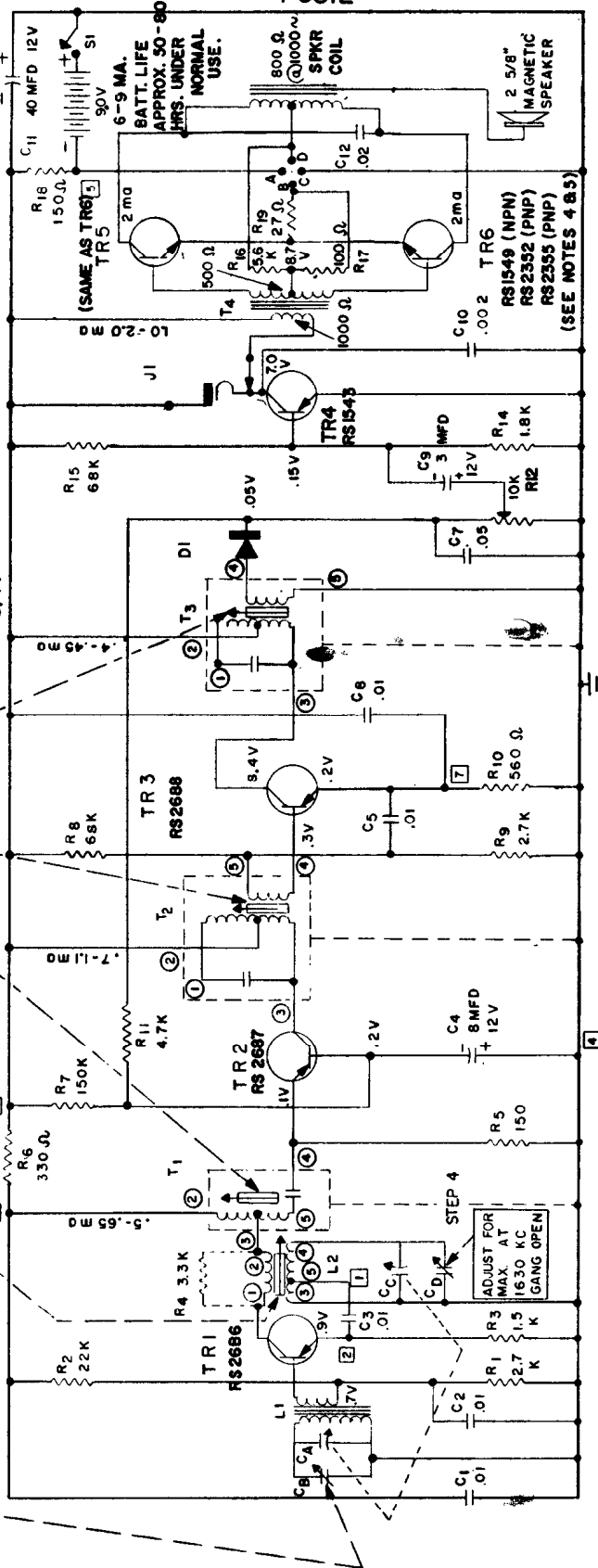

(SEE NOTES 4 & 5)



Exact material for Model RP1100A, Models RP1127A, RP1128A are similar.

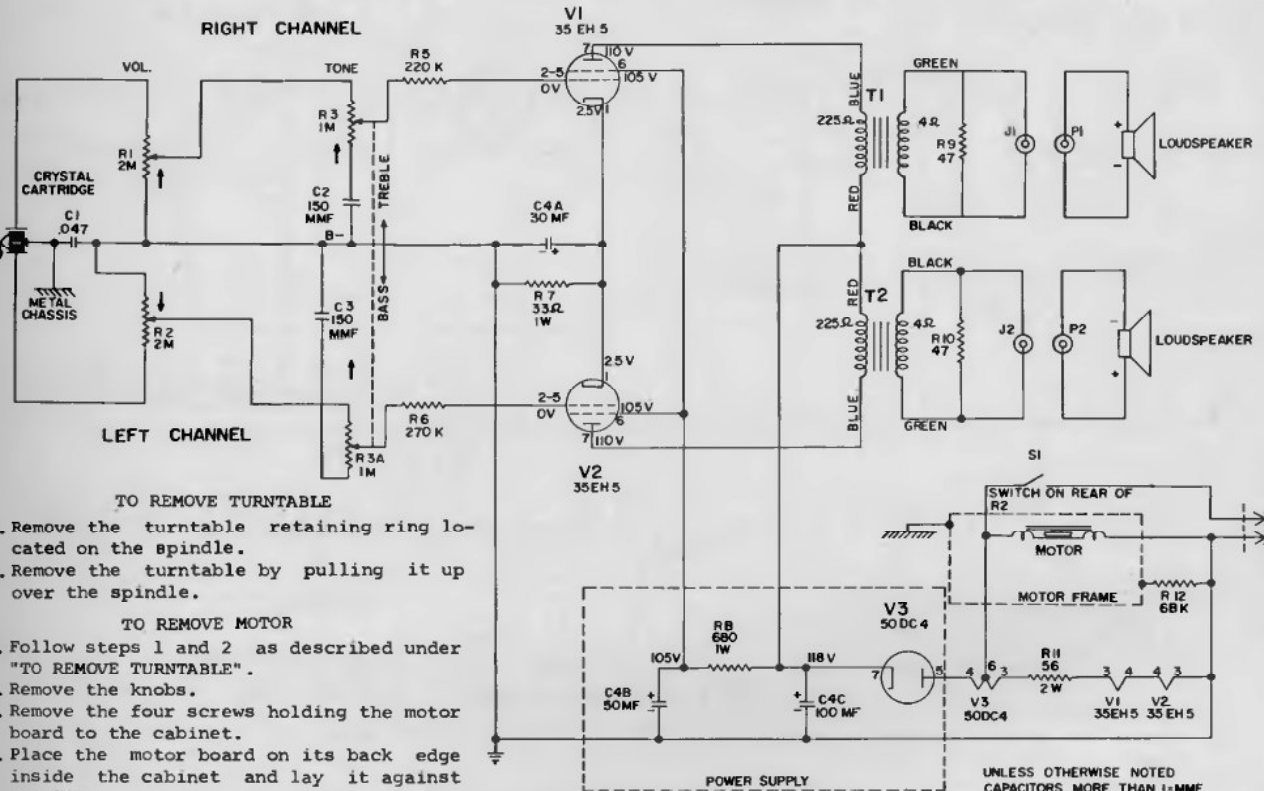

- TO REMOVE TURNTABLE**
1. Remove the turntable retaining ring located on the spindle.
 2. Remove the turntable by pulling it up over the spindle.

- TO REMOVE MOTOR**
1. Follow steps 1 and 2 as described under "TO REMOVE TURNTABLE".
 2. Remove the knobs.
 3. Remove the four screws holding the motor board to the cabinet.
 4. Place the motor board on its back edge inside the cabinet and lay it against the lid.
 5. Remove the 5/16 inch nut holding the ground lug to the motor.
 6. Remove the two plastic Twist Caps on the motor leads.
 7. Place the left hand on the motor and bring the motor board back to a position where the three screws holding the motor to the mounting frame are accessible.
 8. With the right hand, remove the three screws holding motor to the mounting frame. Remove the motor.

TO PHASE SPEAKERS
PLACE A ONE AND ONE-HALF (1½) VOLT BATTERY ACROSS THE VOICE COIL WHEN THE SPEAKER CONE MOVES OUT, AWAY FROM THE MAGNET, THE POSITIVE TERMINAL ON THE BATTERY IS THE PLUS SIDE OF THE VOICE COIL AS INDICATED ON SCHEMATIC.

UNLESS OTHERWISE NOTED CAPACITORS MORE THAN 1-MMF CAPACITORS LESS THAN 1-MMF RESISTORS K=1000 RESISTORS M=1,000,000 DC VOLTAGES AT 120 V LINE TO B-W/20,000Ω/VOLT METER ARROWS INDICATE CLOCKWISE ROTATION

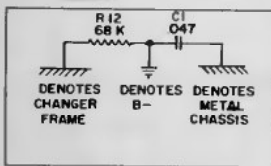

BOARD LAYOUT

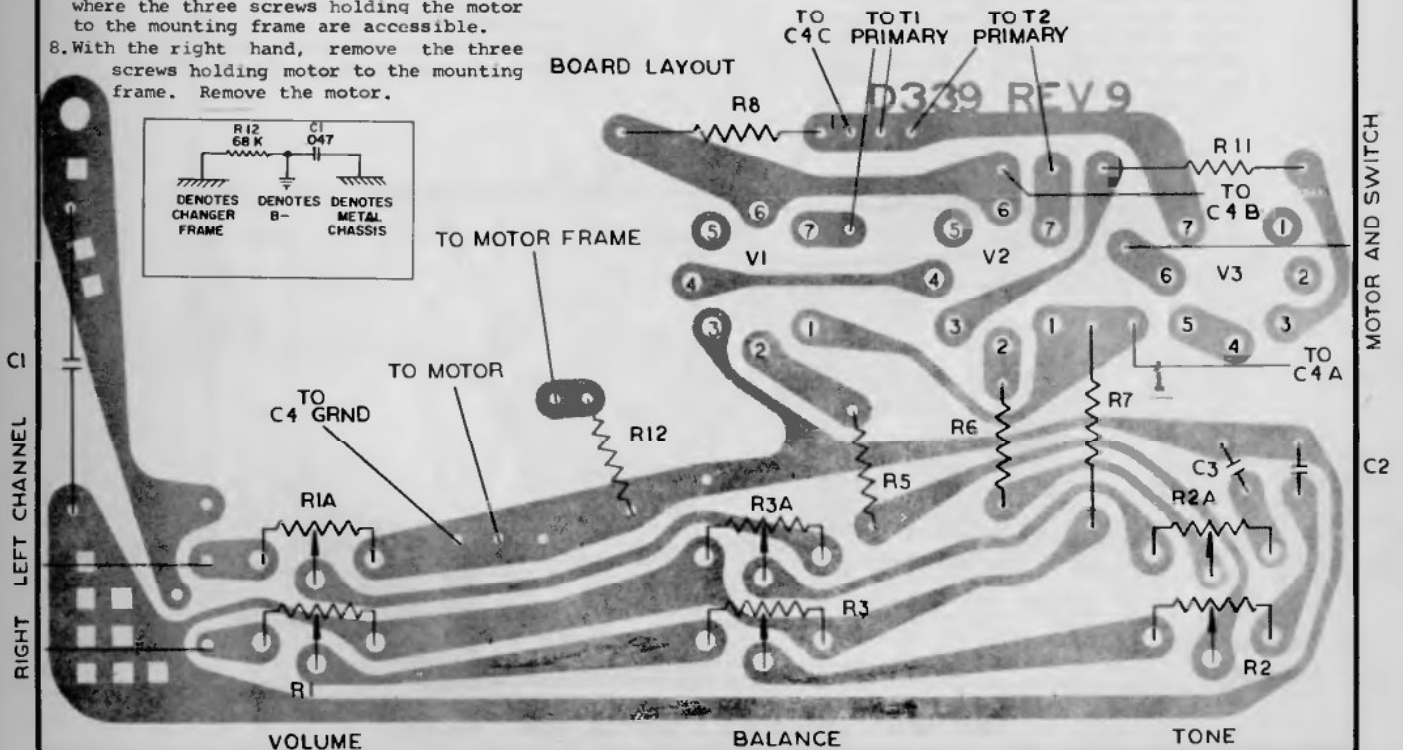

GENERAL ELECTRIC

PHONO
MODEL
RP-III2A

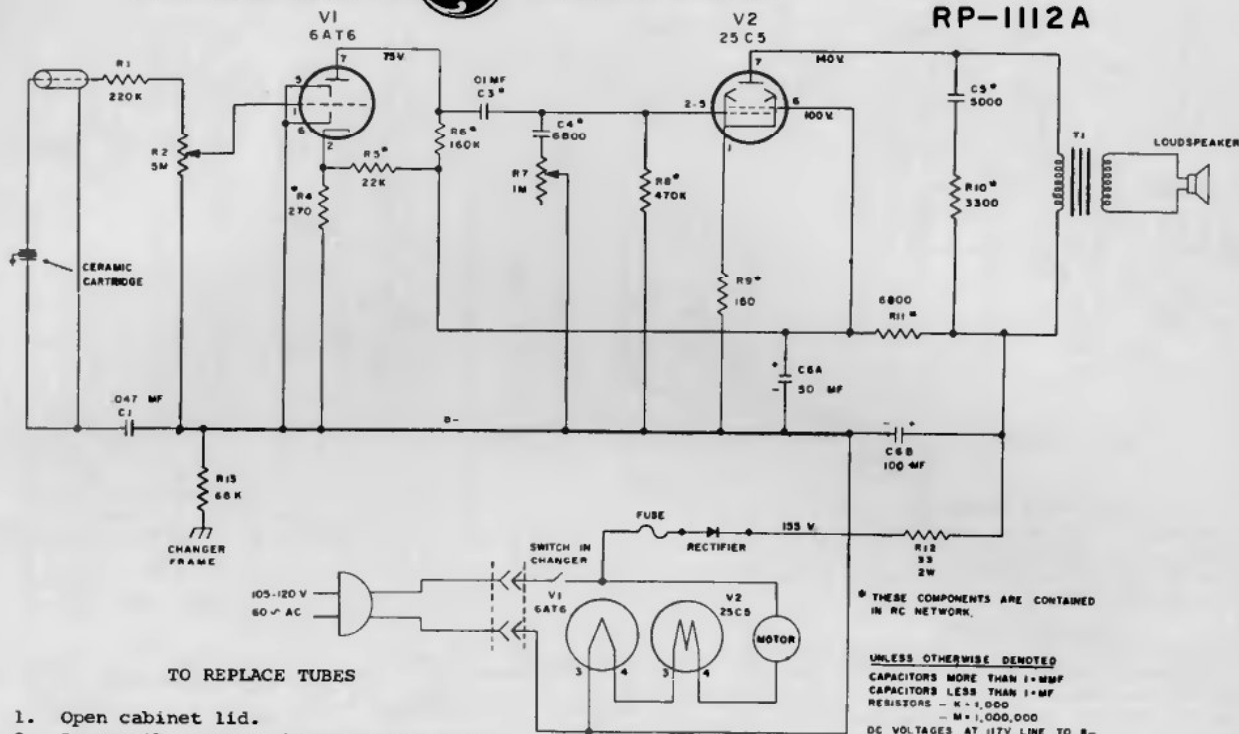

TO REPLACE TUBES

1. Open cabinet lid.
2. Remove the screws holding vent panel board and interlock.
3. Remove vent panel board. (Interlock is automatically disconnected.)

TO REMOVE AMPLIFIER CHASSIS

1. Follow steps 1 thru 3 as above.
2. Remove volume and tone knobs.
3. Loosen screws on interlock bracket, slide interlock out of mounting slot. (Mark location of bracket on cabinet before removing so that bracket can be "keyed" to correct location when replacing.)

4. Remove three screws on cabinet brace above speaker.
 5. Lift out grille (with all electronic components) and place down in front of cabinet carefully.
 6. Remove amplifier chassis by removing the three screws holding chassis to grille.
- When replacing knobs, brace back of each control (volume and tone) with one finger as the knob is pressed on.

* THESE COMPONENTS ARE CONTAINED IN RC NETWORK.

UNLESS OTHERWISE DENOTED
CAPACITORS MORE THAN 1 μMF
CAPACITORS LESS THAN 1 μMF
RESISTORS - K = 1,000
- M = 1,000,000
DC VOLTAGES AT 117V LINE TO 8-
W/20,000 Ω / VOLT METER

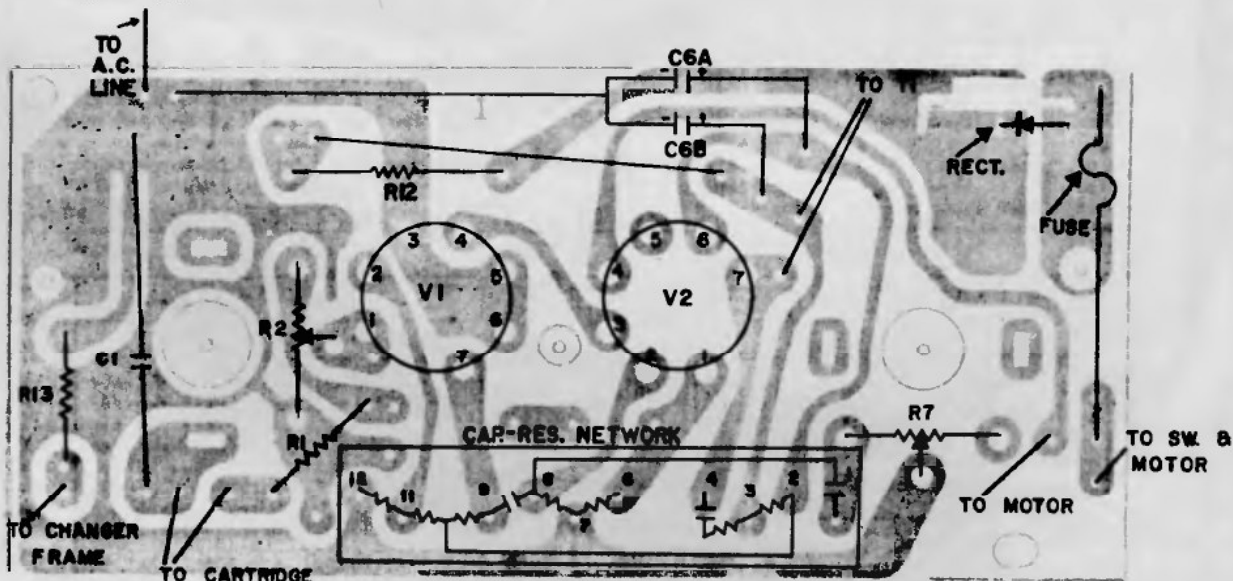

COMPONENT LOCATIONS - BOTTOM VIEW - RP-III0A

VOLUME R-21, MOST-OFTEN-NEEDED

INFORMATION

Hitachi

MODEL TH-627R

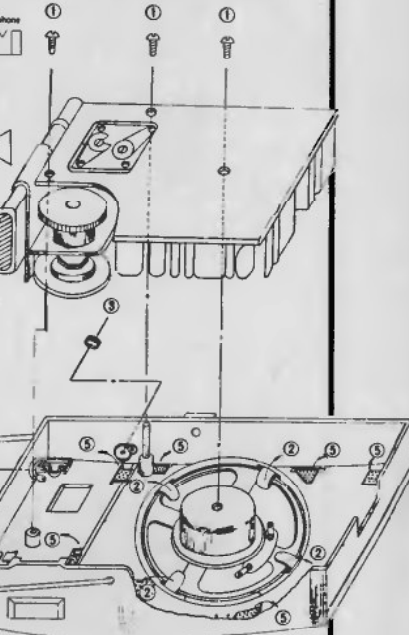
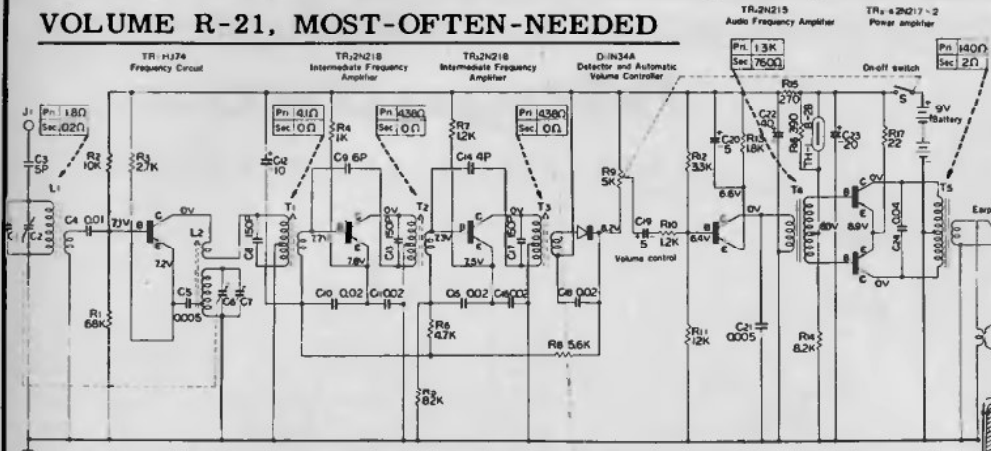

Hitachi, Ltd.

Tokyo Japan

MODEL TH-627R

Tuning range BC 535~1,605 kc.
Intermediate frequency 455 kc.

Dial string assembly

Receiver assembly

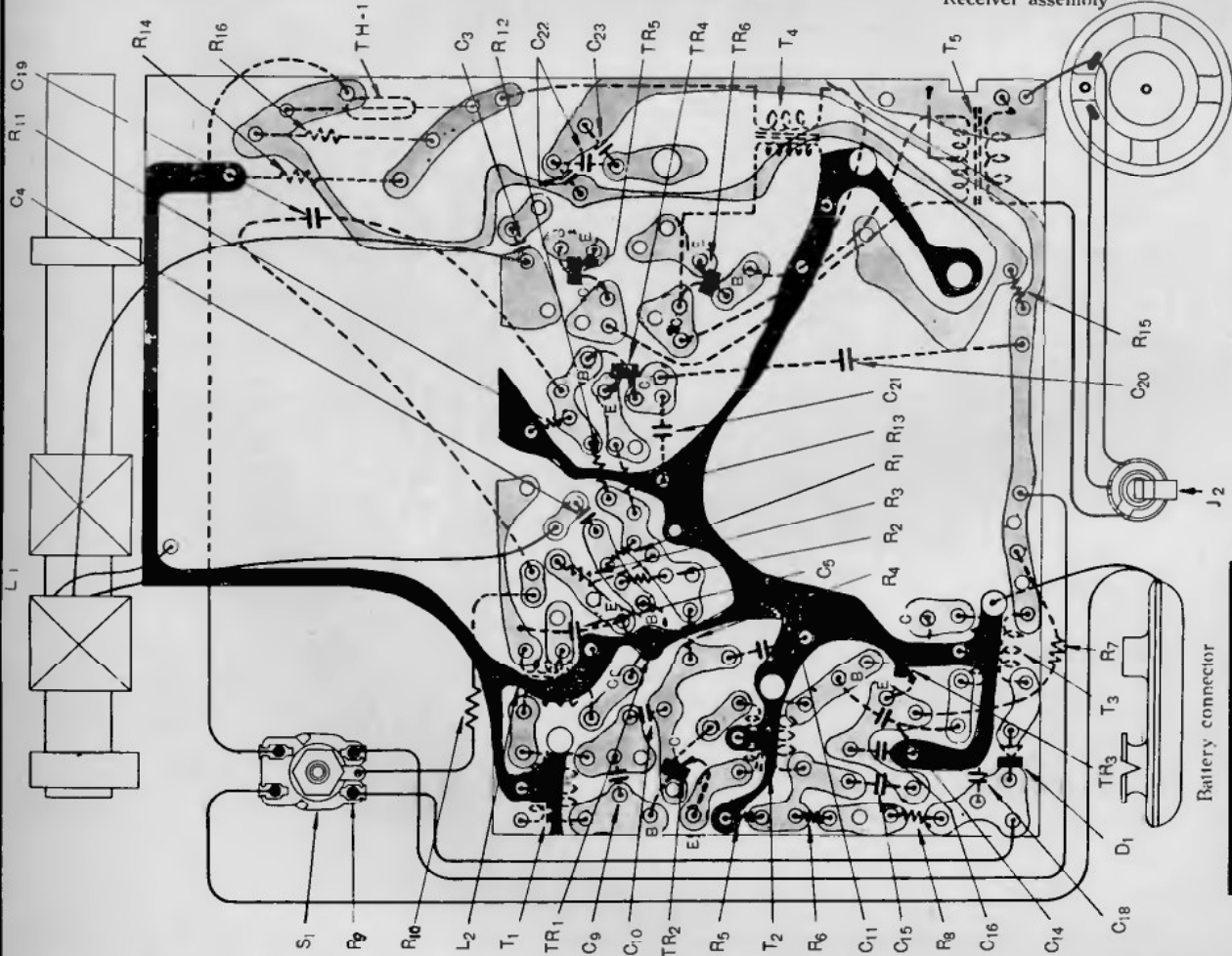

Circuit Board Diagram

Magnavox

65-01 SERIES RADIO CHASSIS

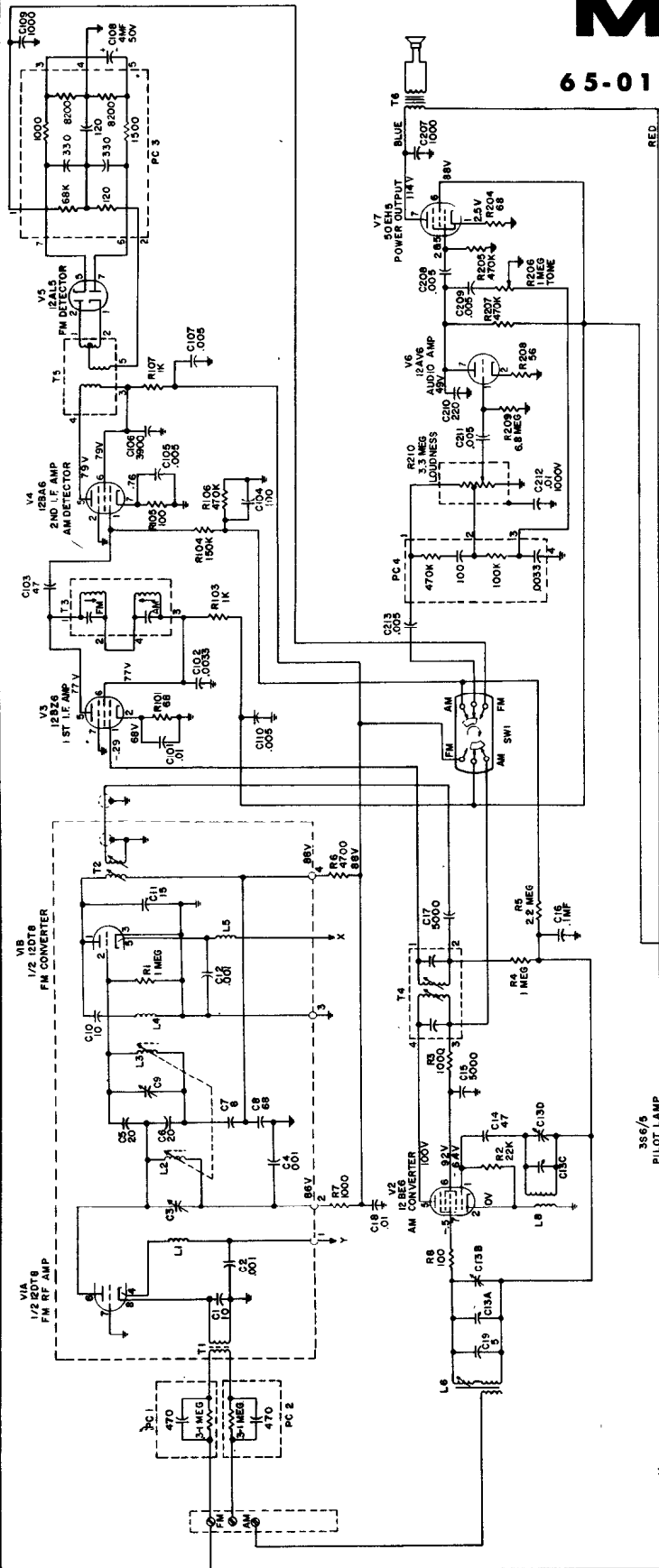

The 65-01 is a series-filament wired AM-FM radio chassis. The chassis contains seven tubes and a selenium diode as a rectifier. An isolation transformer should be used when servicing the chassis.

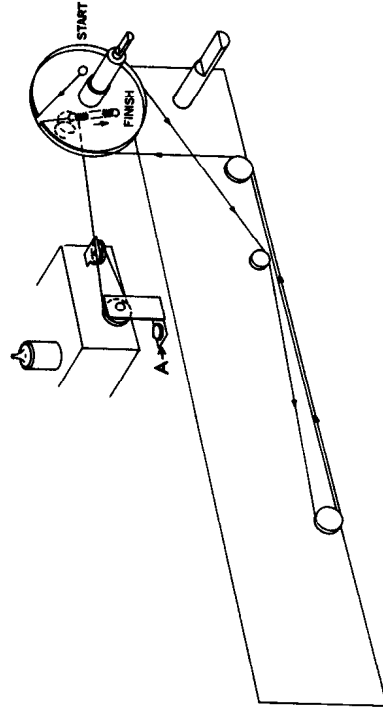

DIAL STRINGING GUIDE

SPECIFICATIONS

Power Source Rating	60 cps.
Frequency	117 volts
Voltage	60 watts
Wattage	
Tuning Frequency Range	540-1620KC
Broadcast Band	88-108MC
FM Band	455KC
IF Frequency (AM)	10.7MC
IF Frequency (FM)	

NOTES
 1. ALL VOLTAGES MEASURED IN FM POSITION EXCEPT 12BE6
 2. LINE VOLTAGE 117V

MONTGOMERY WARD

Radio Models GEN-2030A, GEN-2030B

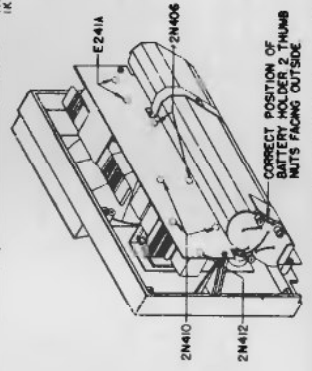
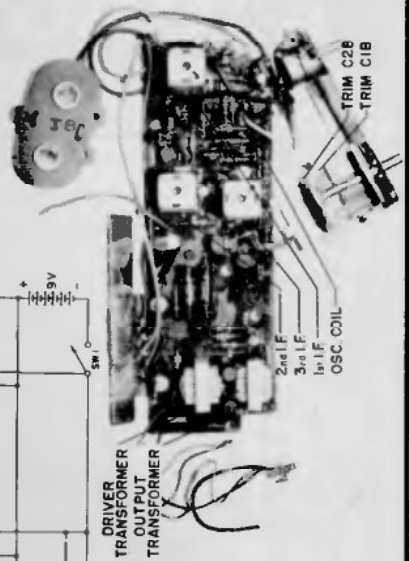
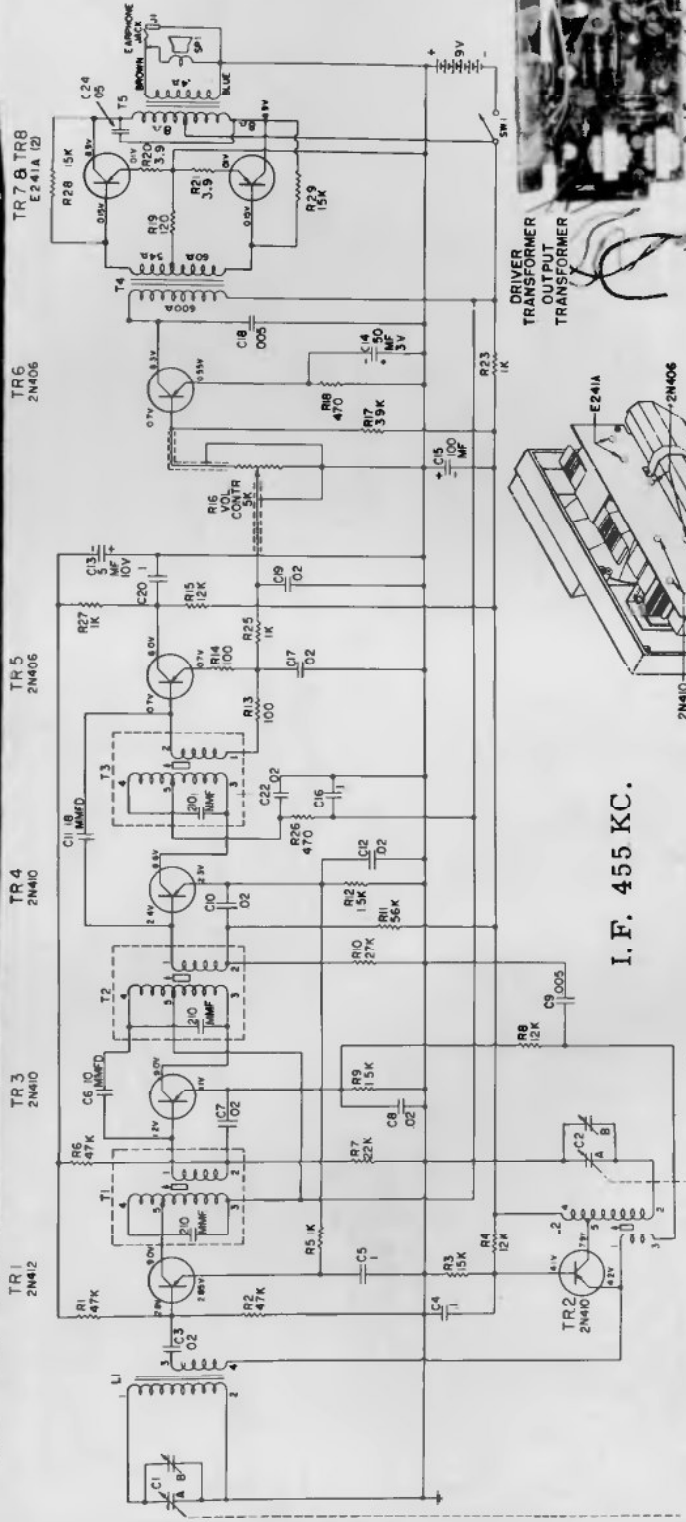
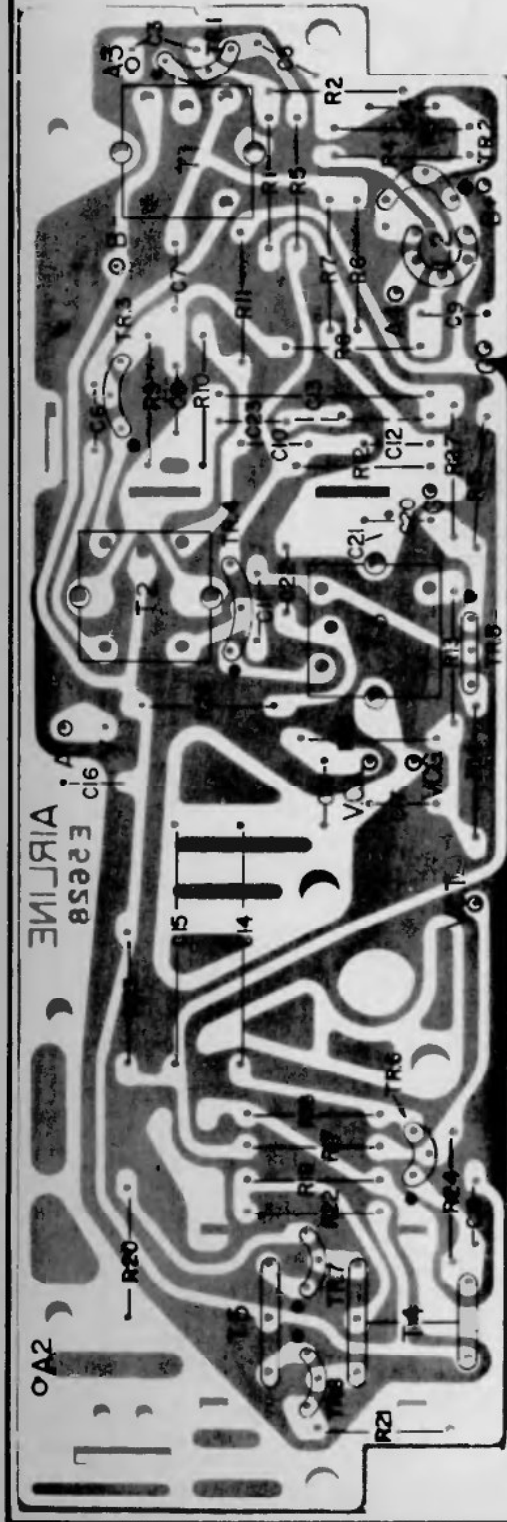

I. F. 455 KC.

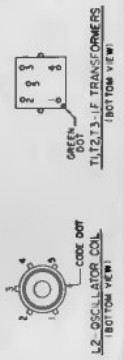

- NOTES:
1. LOCATIONS SHOWN AT EACH TRANSISTOR ELECTRODE
 2. ALL CAPACITANCE VALUES ARE IN MICROGRAMS
 3. ALL RESISTANCE VALUES ARE IN OHMS, UNLESS OTHERWISE INDICATED

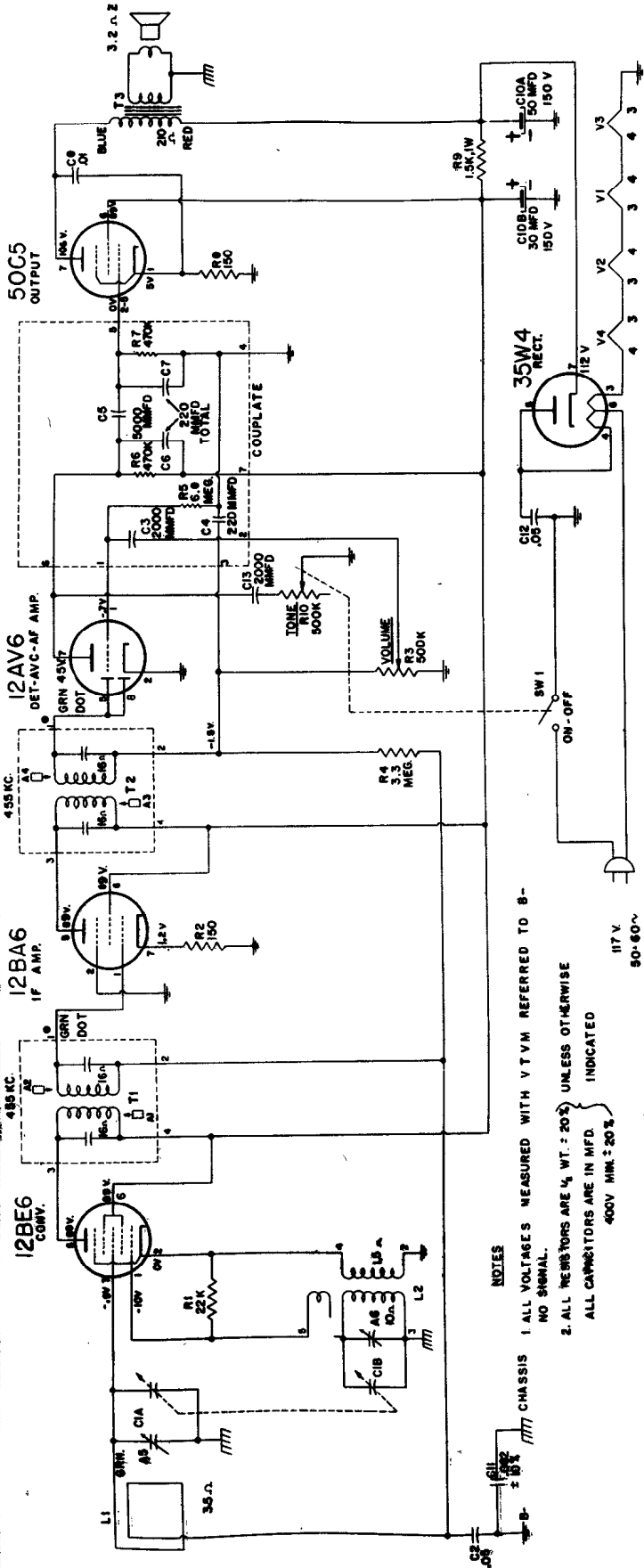

NOTES
 1. ALL VOLTAGES MEASURED WITH VTVM REFERRED TO 8- NO SIGNAL.
 2. ALL RESISTORS ARE 1/4 WT. ± 20% UNLESS OTHERWISE INDICATED
 400V MIN. ± 20%

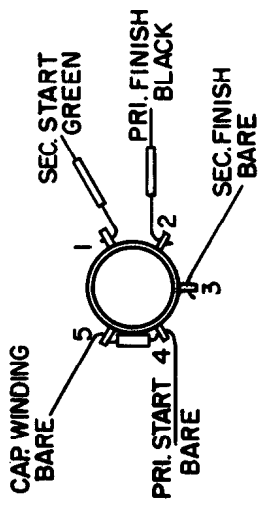

L2-OSCILLATOR COIL (BOTTOM VIEW)

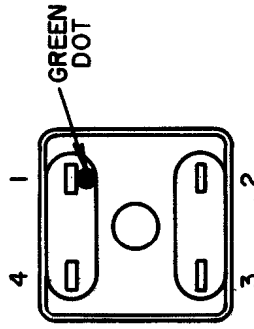

T1, T2-IF TRANSFORMERS (BOTTOM VIEW)

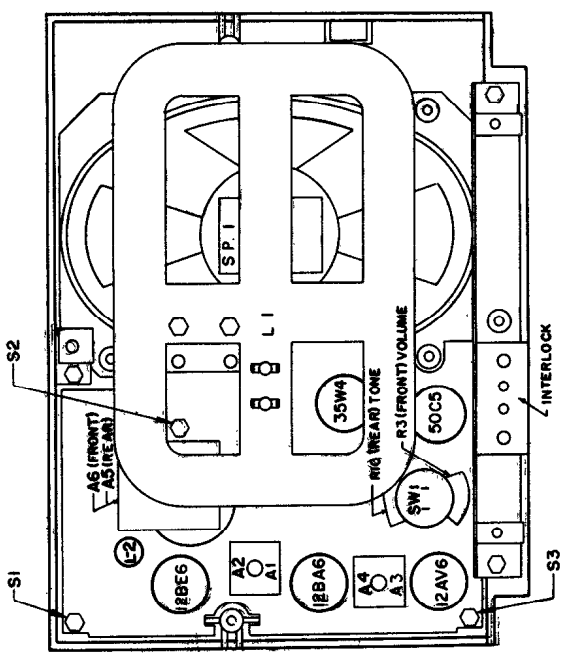

MONTGOMERY WARD
 Radio Models GEN-1667A and GEN-1668A

MOTOROLA

MODEL
10AX

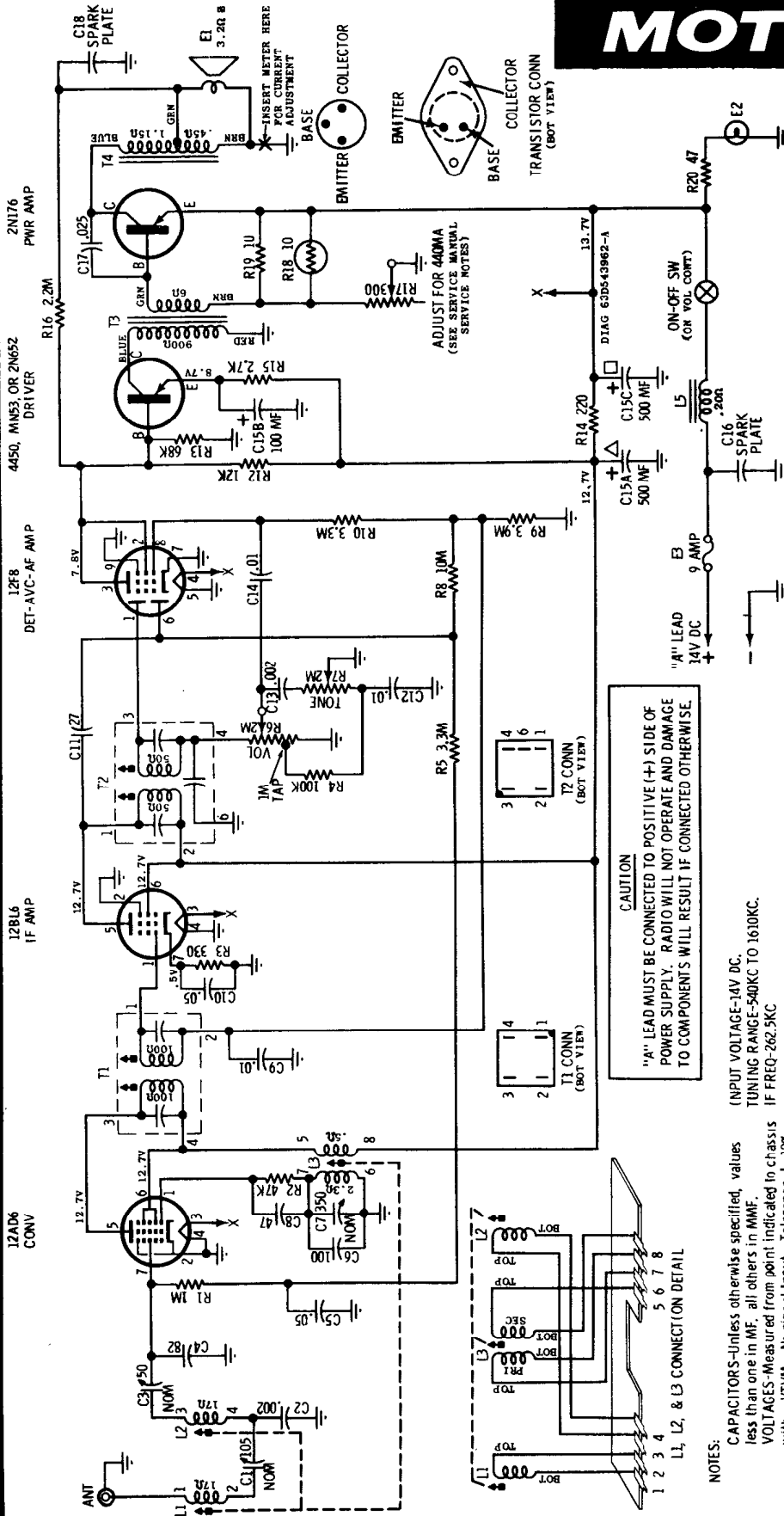

POWER TRANSISTOR CURRENT ADJUSTMENT - After a power transistor has been replaced, the collector current should be checked and adjusted for proper operation.

- Insert a low range (0-1 or 0-2 amp) DC ammeter in the primary ground return lead of the output transformer (T4). Be sure the speaker ground lead is connected in common with the transformer ground lead to the positive meter terminal. Connect negative terminal of the meter to ground.
 - Turn the radio on and allow it to heat up for about 15 minutes.
 - Adjust R17 for a reading of 360 ma with 12.6 volts input to the radio "A" lead.
- NOTE: Two values of radio input voltage are given as a convenience to service personnel in order to accommodate different power sources. The current value stated on the Schematic Diagram is for 14 volts input to the radio "A" lead.

CAUTION
"A" LEAD MUST BE CONNECTED TO POSITIVE (+) SIDE OF POWER SUPPLY. RADIO WILL NOT OPERATE AND DAMAGE TO COMPONENTS WILL RESULT IF CONNECTED OTHERWISE.

INPUT VOLTAGE-14V DC.
TUNING RANGE-540KC TO 1610KC.
IF FREQ-262.5KC

NOTES:
CAPACITORS-Unless otherwise specified, values less than one in MF. all others in MMF.
VOLTAGES-Measured from point indicated in chassis with a VTVM. No signal input. Tolerance $\pm 10\%$

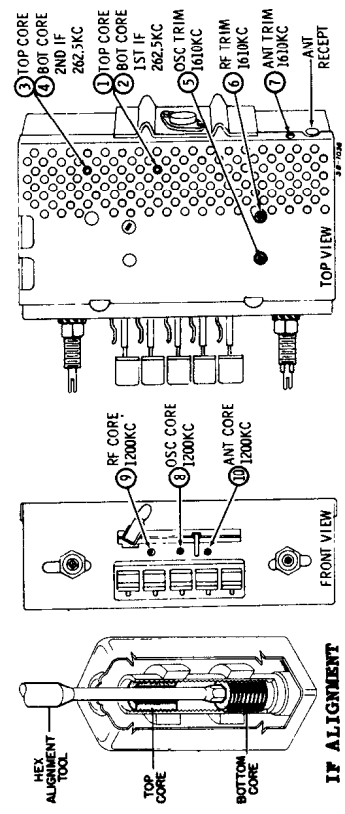

ALIGNMENT POINTS LOCATION DETAIL

IF ALIGNMENT DETAIL

MOTOROLA INC.

AUTO RADIO
MODEL
MOTOROLA 13MA
AMERICAN MOTORS
8990832

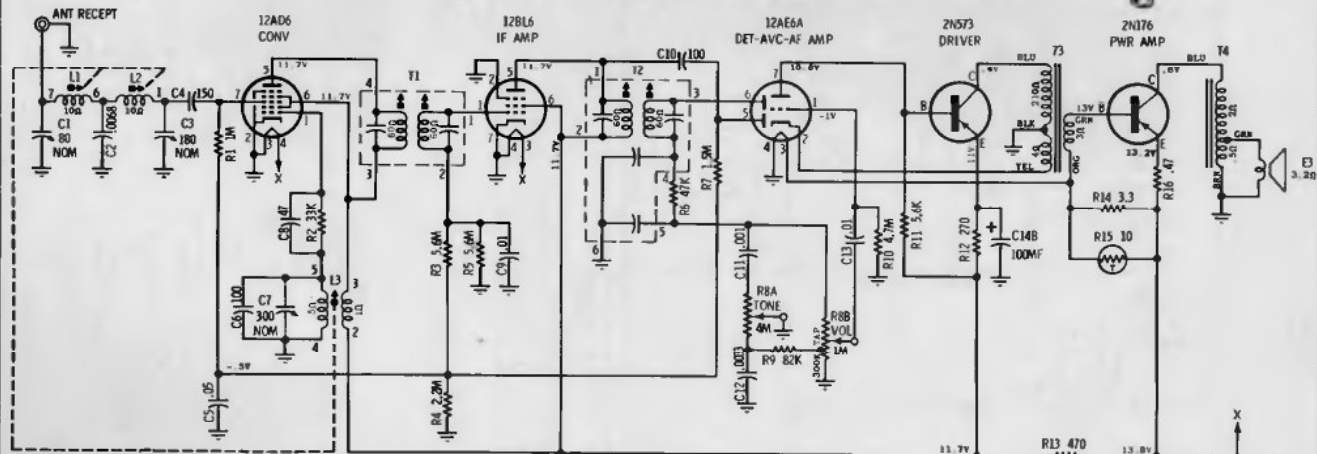
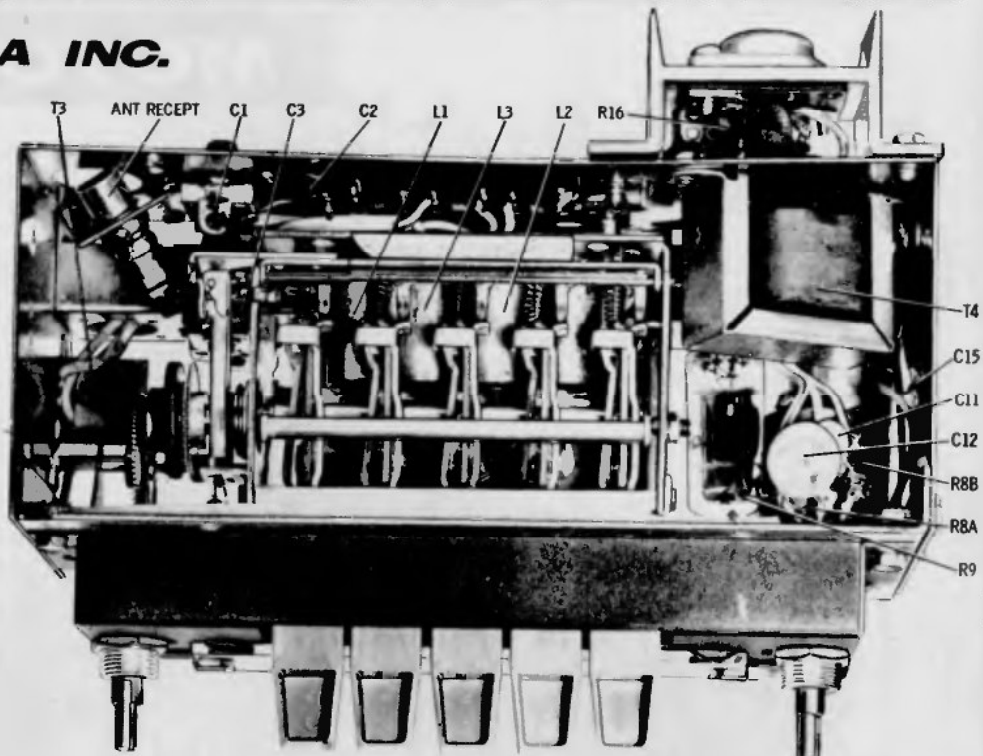

NOTES:

CAPACITORS—Unless otherwise specified, decimal values in MF; all others in MMF. VOLTAGES—Measured from point indicated to chassis. ± 10%. No signal input. INPUT VOLTAGE—14V DC. TUNING RANGE—540 KC to 1610 KC IF—262.5 KC

CAUTION
 "A" LEAD MUST BE CONNECTED TO POSITIVE (+) SIDE OF POWER SUPPLY. RADIO WILL NOT OPERATE AND DAMAGE TO COMPONENTS WILL RESULT IF CONNECTED OTHERWISE.

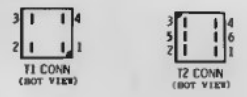

- 2ND IF 262.5 KC TOP ① BOT ②
- RF CORE 1020 KC ⑨
- OSC CORE 1020 KC ⑧
- 1ST IF 262.5 KC TOP ④ BOT ③
- ANT CORE 1020 KC ⑩
- OSC TRIM 1610 KC ⑤
- RF TRIM 1610 KC ⑥
- ANT TRIM 1200 KC ⑦

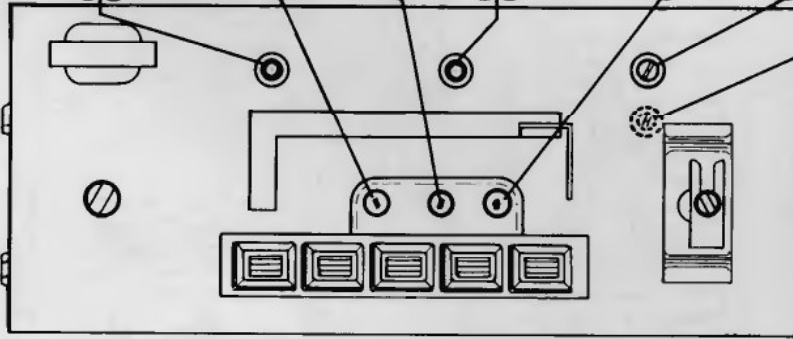

FRONT VIEW (WITH DIAL SCALE & BACKGROUND REMOVED)

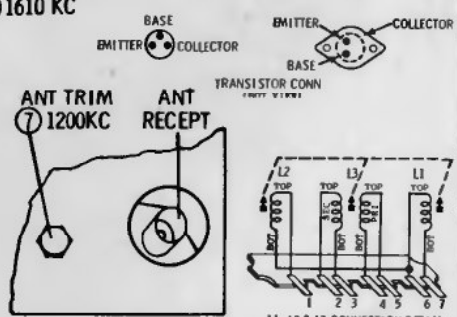

BACK VIEW

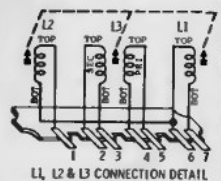

L1, L2 & L3 CONNECTION DETAIL



MODEL
MOTOROLA 13MAM
AMERICAN MOTORS 8990831

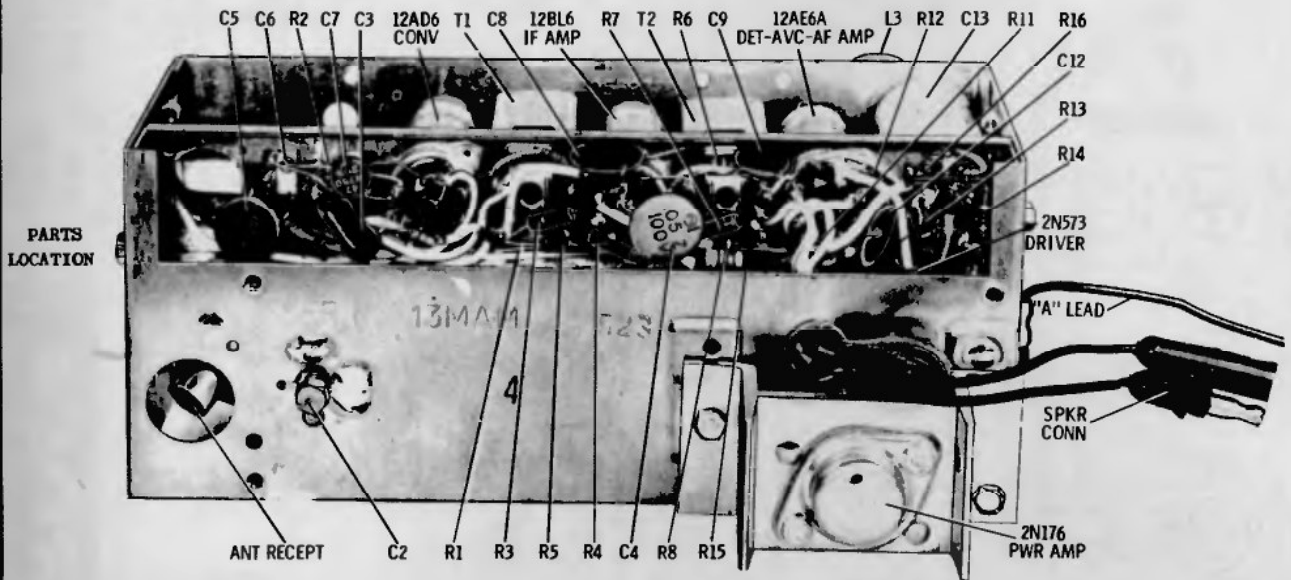

CAUTION
"A" LEAD MUST BE CONNECTED TO POSITIVE (+) SIDE OF POWER SUPPLY. RADIO WILL NOT OPERATE AND DAMAGE TO COMPONENTS WILL RESULT IF CONNECTED OTHERWISE.

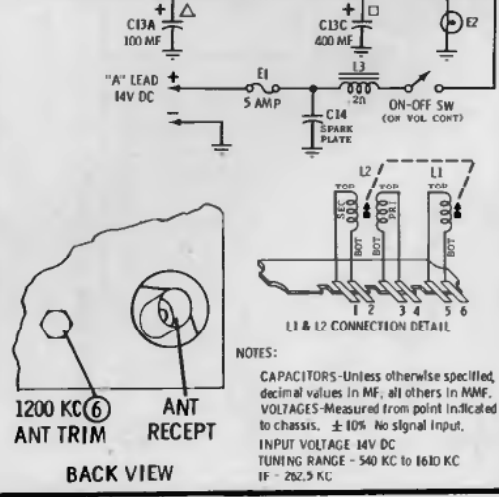
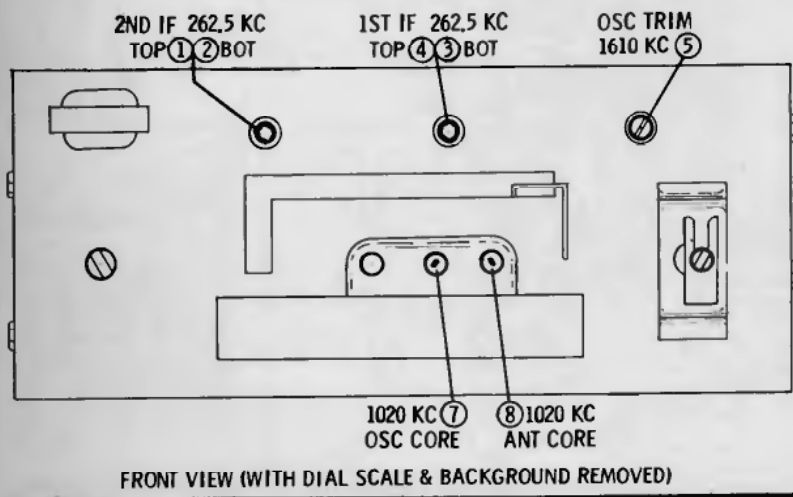
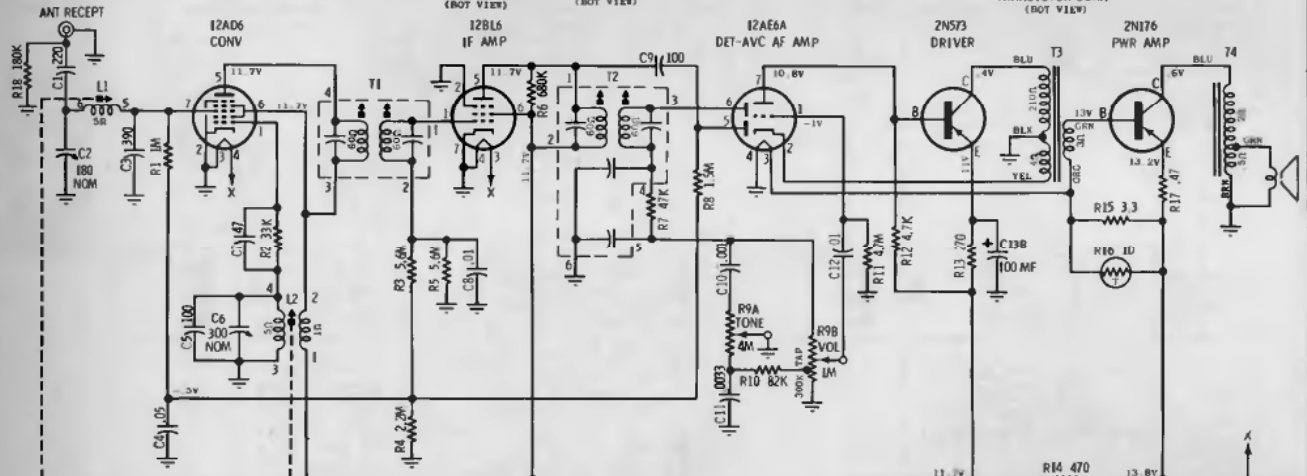
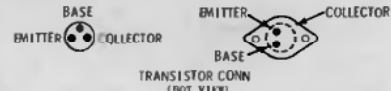

NOTES:
CAPACITORS - Unless otherwise specified, decimal values in MF, all others in MMF.
VOLTAGES - Measured from point indicated to chassis. $\pm 10\%$ No signal input.
INPUT VOLTAGE - 14V DC
TUNING RANGE - 540 KC to 1610 KC
IF - 262.5 KC

VOLUME R-21, MOST-OFTEN-NEEDED 1961 RADIO SERVICING INFORMATION

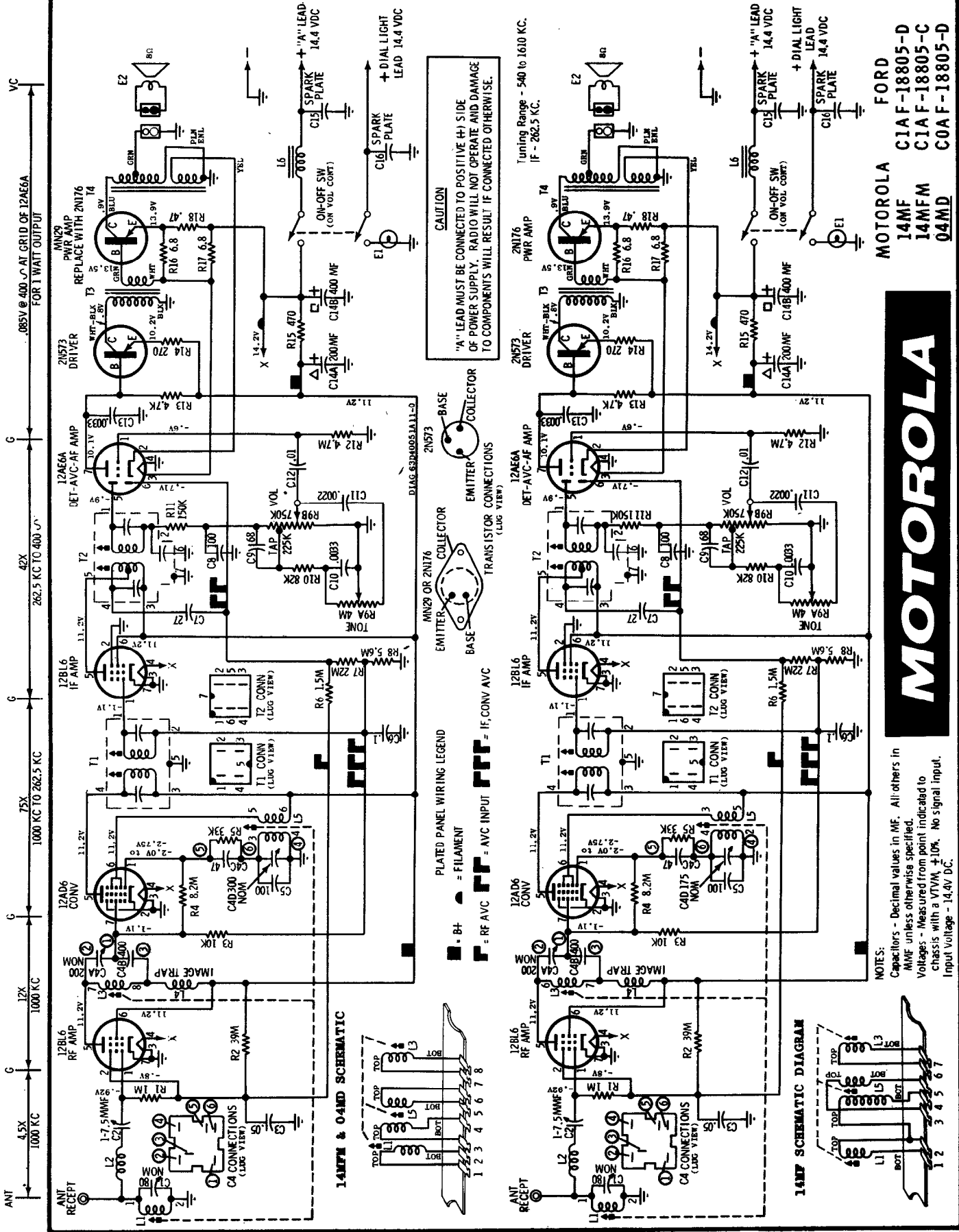

MOTOROLA FORD
 14MF C1A F-18805-D
 14MFM C1A F-18805-C
 04MD C0A F-18805-D

MOTOROLA

NOTES:
 Capacitors - Decimal values in MF. All others in μ MF unless otherwise specified.
 Voltages - Measured from point indicated to chassis with a VTVM, $\pm 10\%$. No signal input.
 Input Voltage - 14.4V DC.

(Additional service material is on the next page, adjacent at right)

(Continued from preceding page)

MOTOROLA INC.

MODELS

MOTOROLA	FORD
14MF	C1A F-18805-D
14MFM	C1A F-18805-C
04MD	C0A F-18805-D

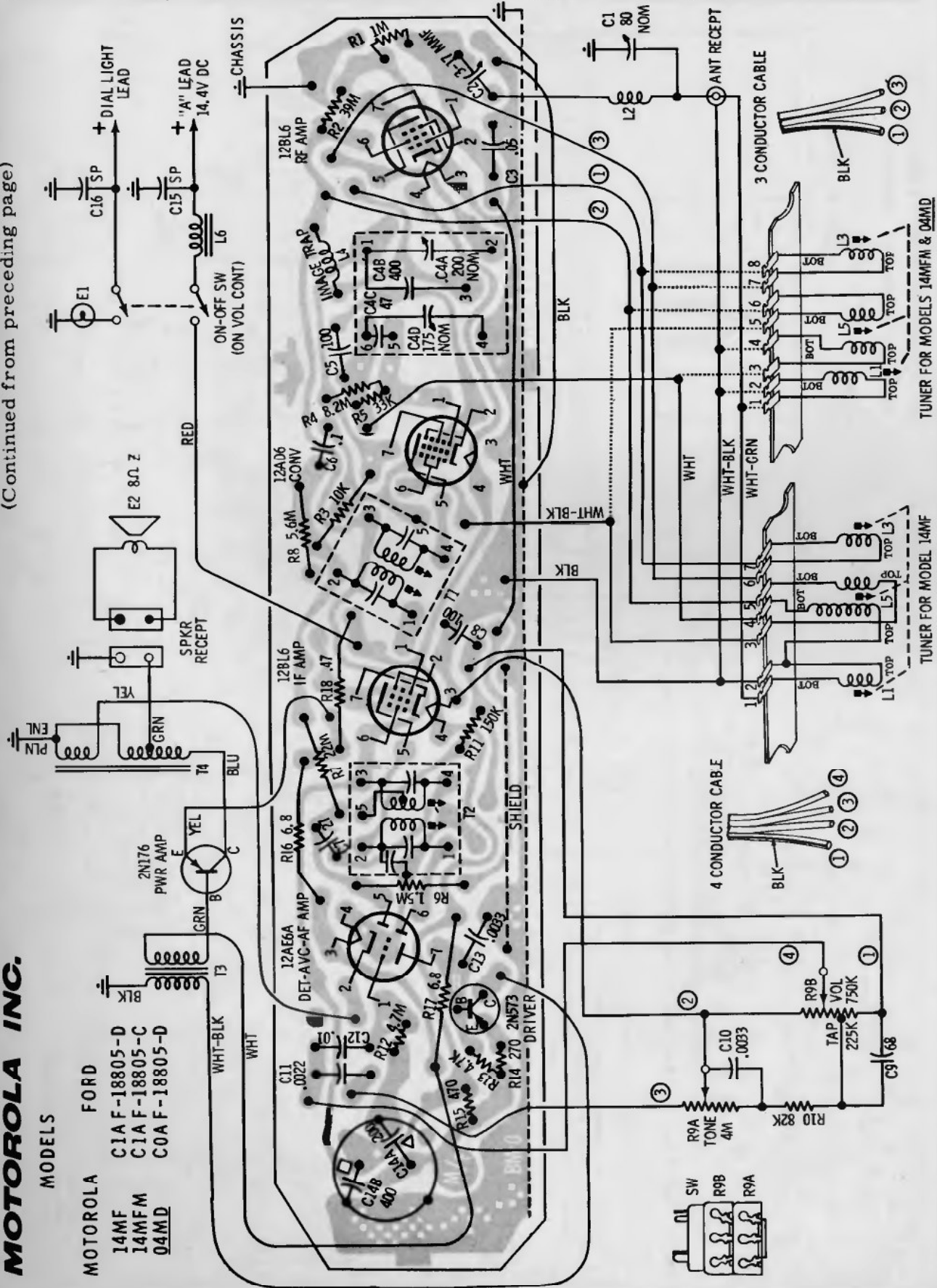

TUNER FOR MODELS 14MFM & 04MD

TUNER FOR MODEL 14MF

PLATED CHASSIS BOARD WIRING AS VIEWED FROM BOTTOM SIDE (COMPONENTS SHOWN ARE ON OPPOSITE SIDE)

MOTOROLA Model 14MR
American Motors 8990833

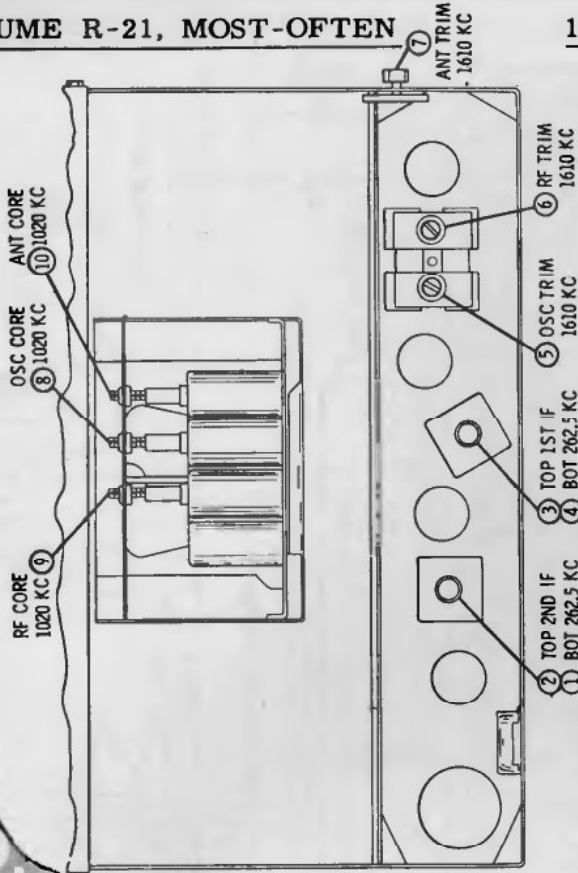

ALIGNMENT POINTS LOCATION DETAIL

R19 is used to limit total collector current. In most sets it is a piece of copper wire; in a few sets it is a 1/2 watt carbon resistor, either 27 or 56 ohms.

PLATED CHASSIS BOARD GROUND CONNECTIONS AS SEEN THRU BOARD FROM WIRING SIDE

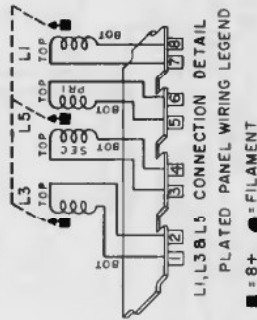

L1, L3, L5 CONNECTION DETAIL

PLATED PANEL WIRING LEGEND

■ = 8+ FILAMENT

■ = RF. AVC. IF. CONV. AVC

CAUTION
"A" LEAD MUST BE CONNECTED TO POSITIVE (+) SIDE OF POWER SUPPLY. RADIO WILL NOT OPERATE AND DAMAGE TO COMPONENTS WILL RESULT IF CONNECTED OTHERWISE

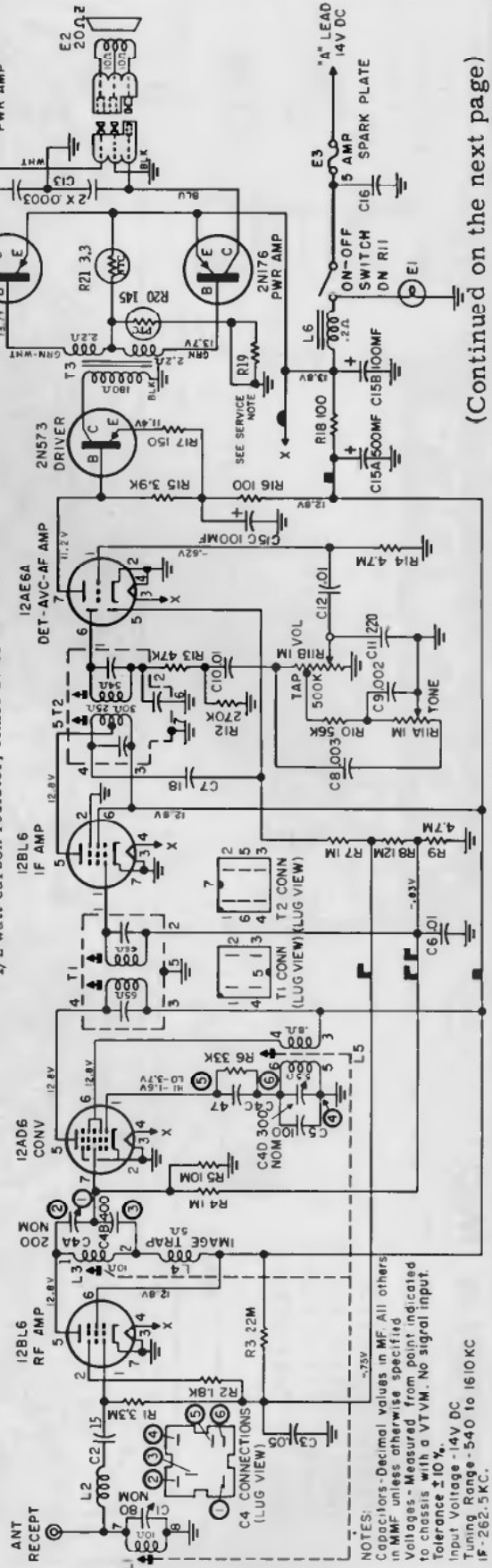
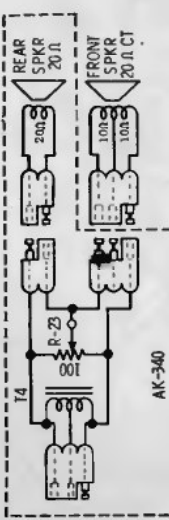

NOTES:
Capacitors: Decimal values in MF. All others in MMF unless otherwise specified.
Voltages: - Measured from point indicated to chassis with a VTVM. No signal input.
Tolerance: ±10%.
Input Voltage: 14V DC
Tuning Range: 540 to 1610 KC.

(Continued on the next page)

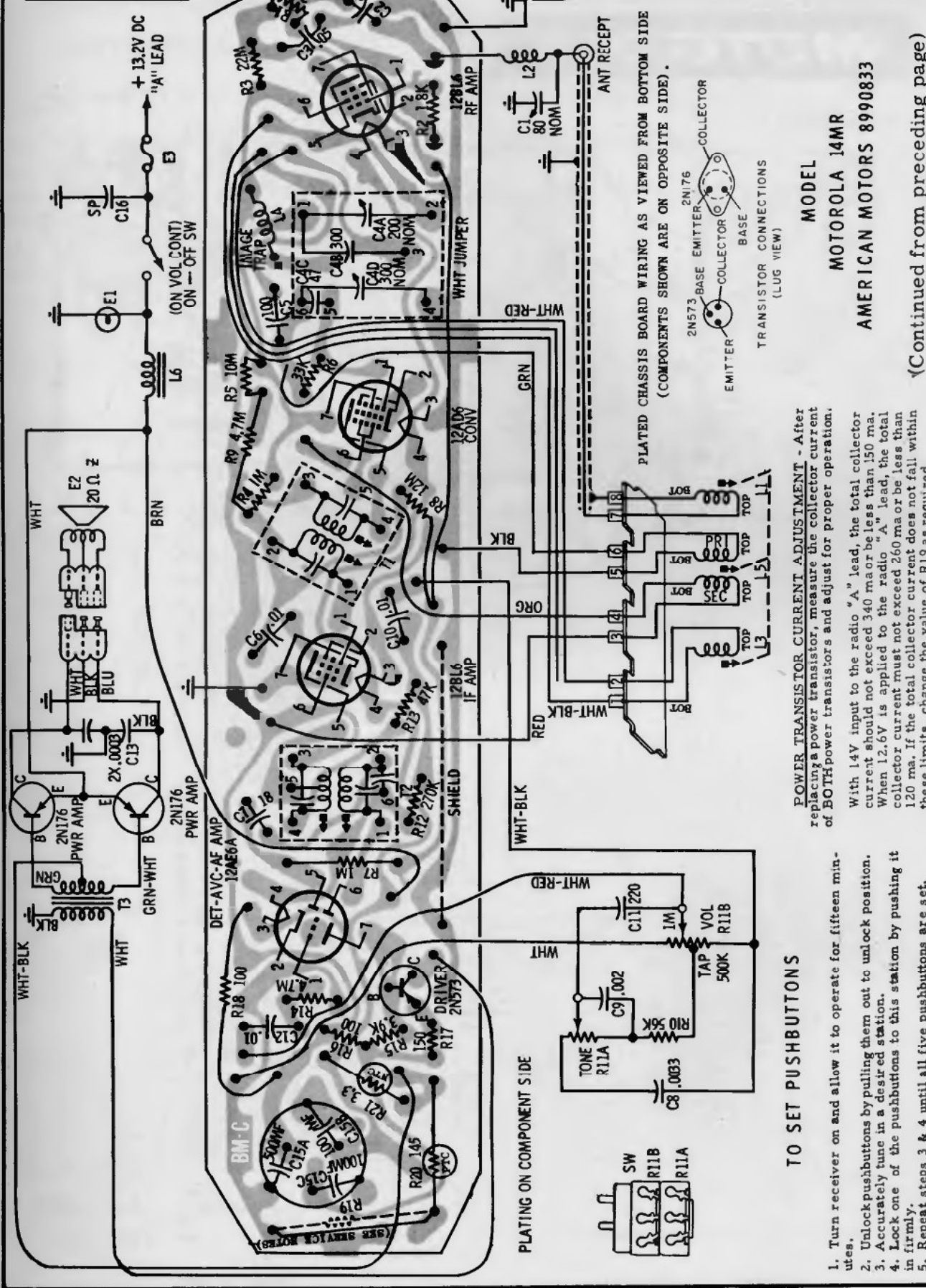

MODEL
MOTOROLA 14MR
AMERICAN MOTORS 8990833

(Continued from preceding page)

POWER TRANSISTOR CURRENT ADJUSTMENT - After replacing a power transistor, measure the collector current of BOTH power transistors and adjust for proper operation.

With 14V input to the radio "A" lead, the total collector current should not exceed 340 ma or be less than 150 ma. When 12.6V is applied to the radio "A" lead, the total collector current must not exceed 260 ma or be less than 120 ma. If the total collector current does not fall within these limits, change the value of R19 as required.

TO SET PUSHBUTTONS

1. Turn receiver on and allow it to operate for fifteen minutes.
2. Unlock pushbuttons by pulling them out to unlock position.
3. Accurately tune in a desired station.
4. Lock one of the pushbuttons to this station by pushing it in firmly.
5. Repeat steps 3 & 4 until all five pushbuttons are set.

MOTOROLA

AUTO RADIO

MODELS
BKA60X
PCA60X

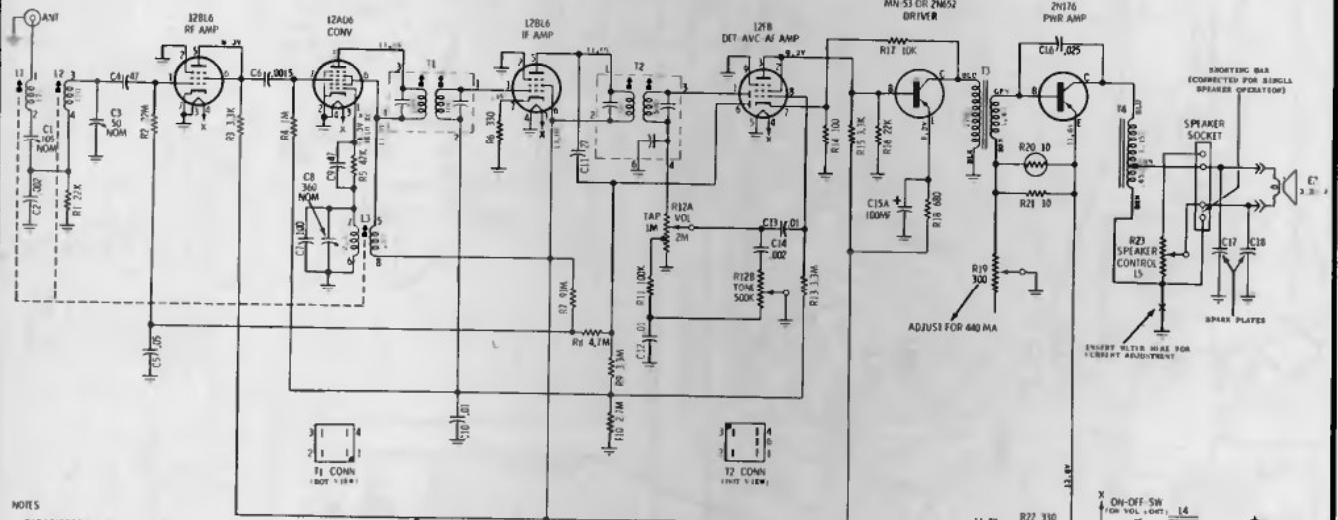
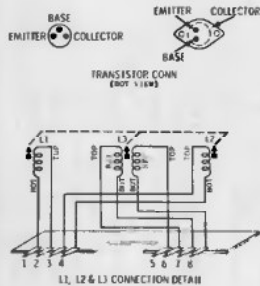
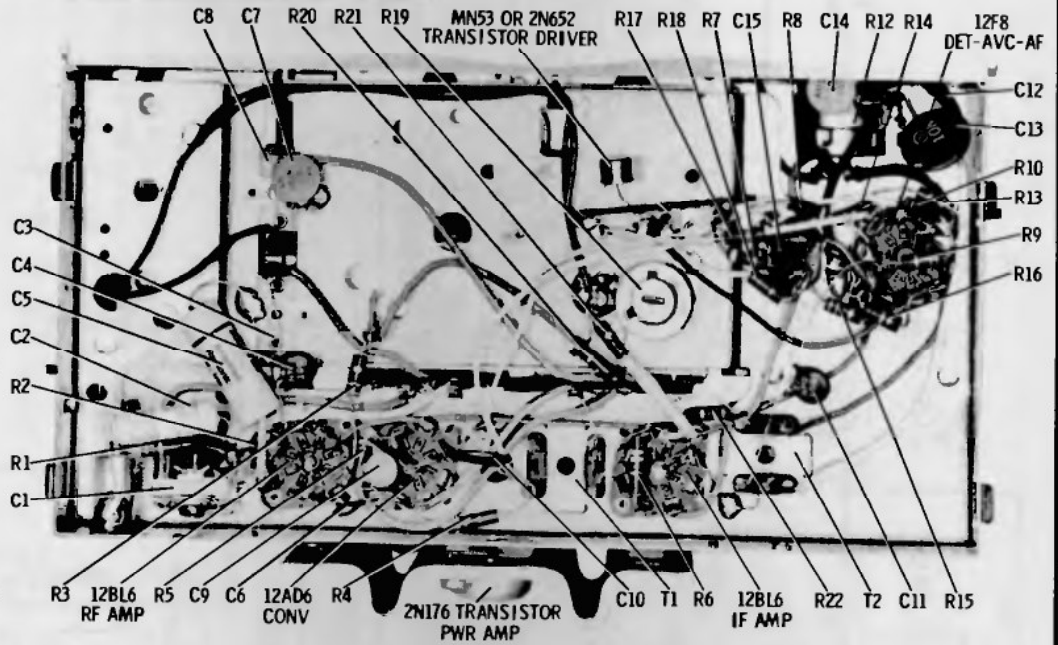

NOTES

CAPACITORS - Decimal values in MF, all others in MM unless otherwise specified.
VOLTAGES - Measured from point indicated to chassis with a VTVM. No signal input. Tolerance $\pm 10\%$.
INPUT VOLTAGE - 14V DC.
TUNING RANGE - 540 KC to 1600 KC, IF FREQ. - 262.5 KC.

CAUTION
A LEAD MUST BE CONNECTED TO POSITIVE B+ SIDE OF POWER SUPPLY. RADIO WILL NOT OPERATE AND DAMAGE TO COMPONENTS WILL RESULT IF CONNECTED OTHERWISE.

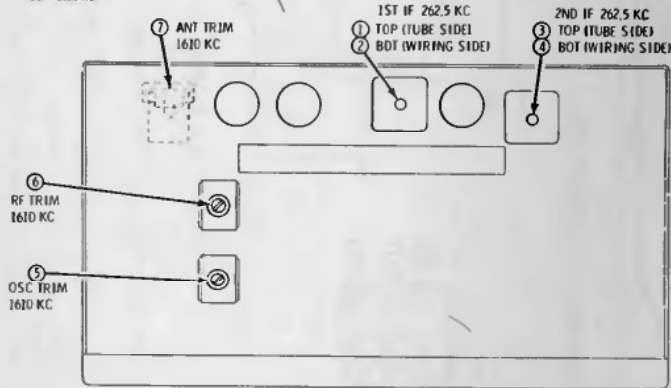

ALIGNMENT LOCATION DETAIL

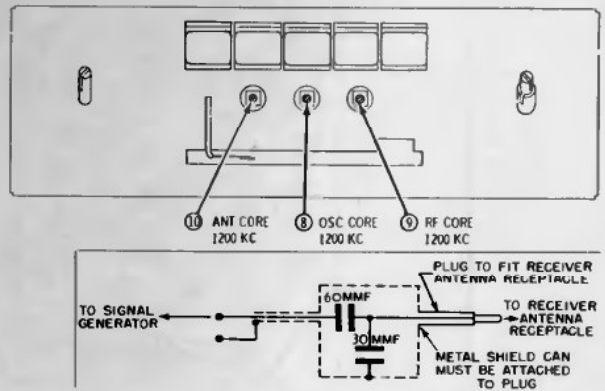

DUMMY ANTENNA

MOTOROLA

AUTO RADIO

MODEL
CRA60X

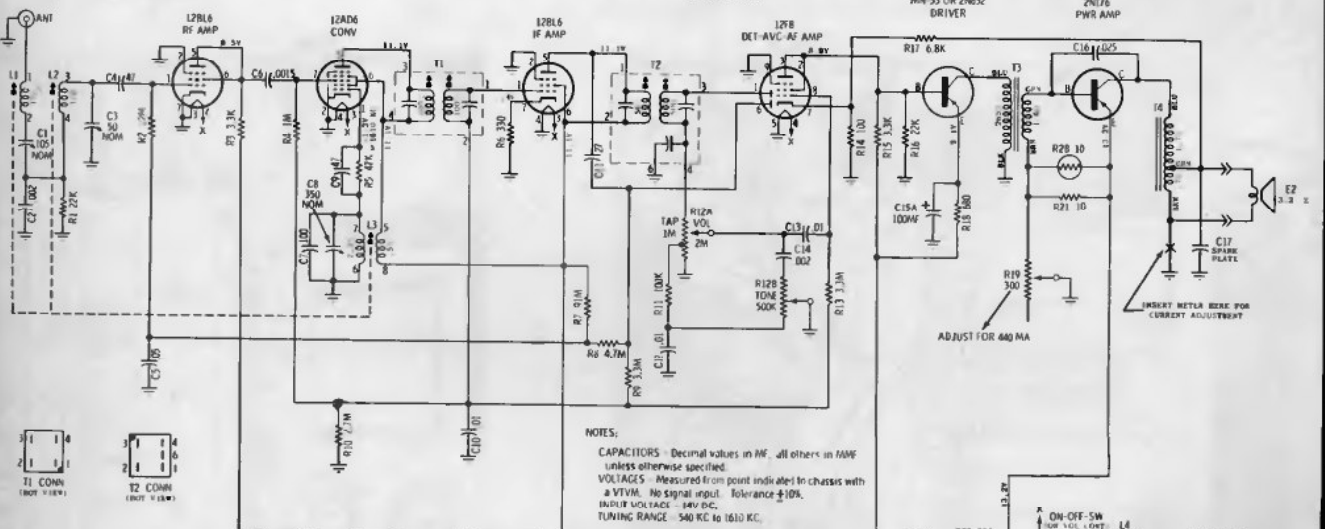
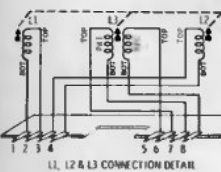
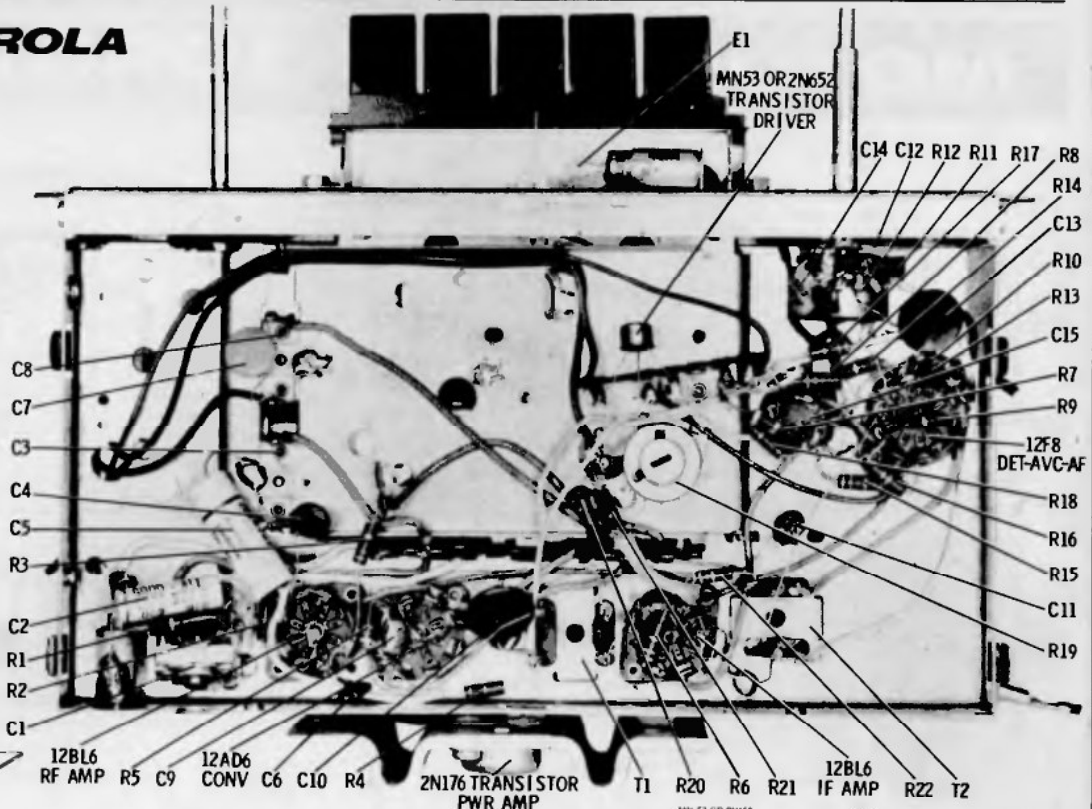

NOTES:
CAPACITORS - Decimal values in μF , all others in $M\mu F$ unless otherwise specified.
VOLTAGES - Measured from point indicated in chassis with a VTVM. No signal input. Tolerance $\pm 10\%$.
BUILT IN TACK - 80V DC.
TUNING RANGE - 540 KC to 1610 KC.

CAUTION
A LEAD MUST BE CONNECTED TO POSITIVE (+) SIDE OF POWER SUPPLY. RADIO WILL NOT OPERATE AND DAMAGE TO COMPONENTS WILL RESULT IF CONNECTED OTHERWISE.

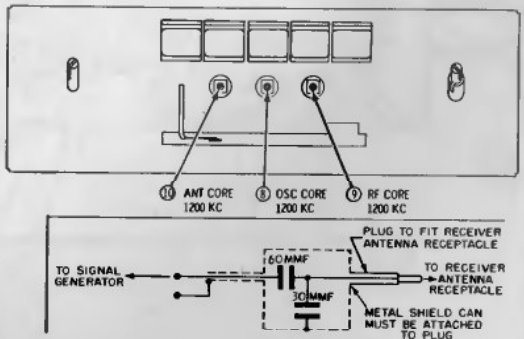
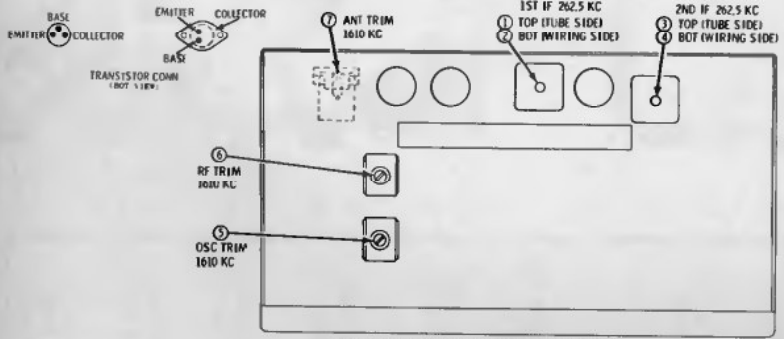

MOTOROLA

MODEL
VWA60

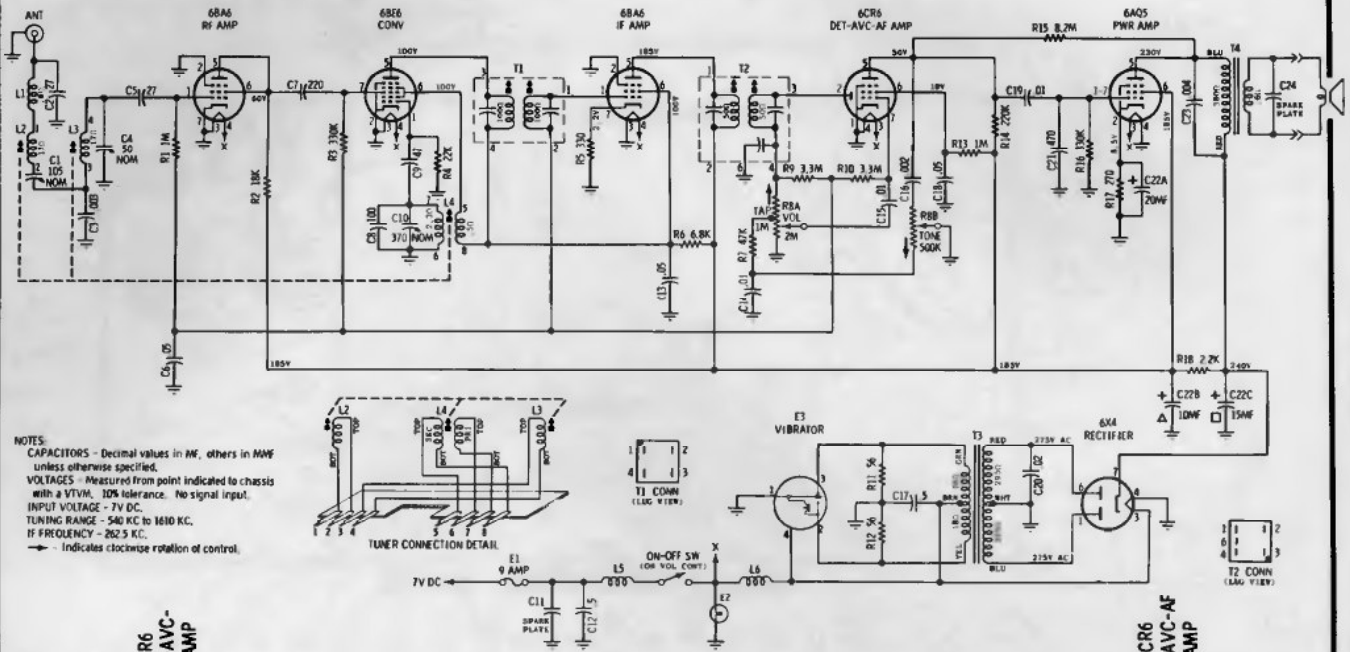

NOTES:
CAPACITORS - Decimal values in MF, others in MMF unless otherwise specified.
VOLTAGES - Measured from point indicated to chassis with a VTVM, 10% tolerance. No signal input.
INPUT VOLTAGE - 7V DC.
TUNING RANGE - 540 KC to 1610 KC.
IF FREQUENCY - 362.5 KC.
↻ Indicates clockwise rotation of control.

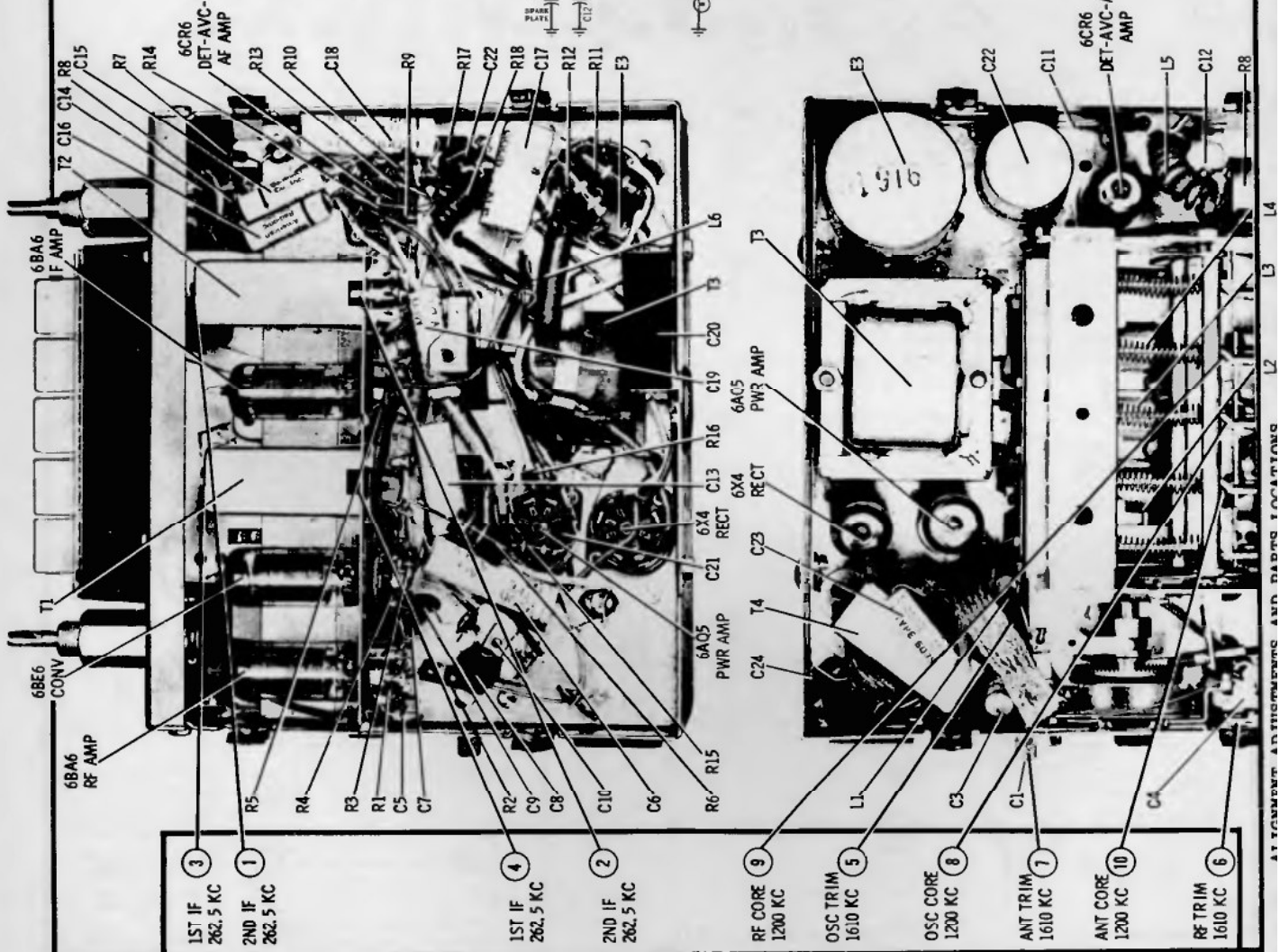
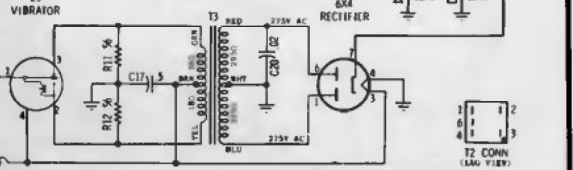
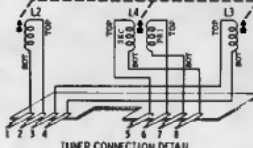

MOTOROLA

AUTO RADIO

MODEL CRM60X

Automotive type superheterodyne receiver designed for custom installation in the 1960 Corvair car. This receiver contains a transistor driver stage, a transistor output stage, and four miniature tubes designed to operate directly from the car's storage battery.

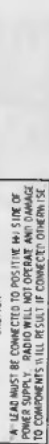
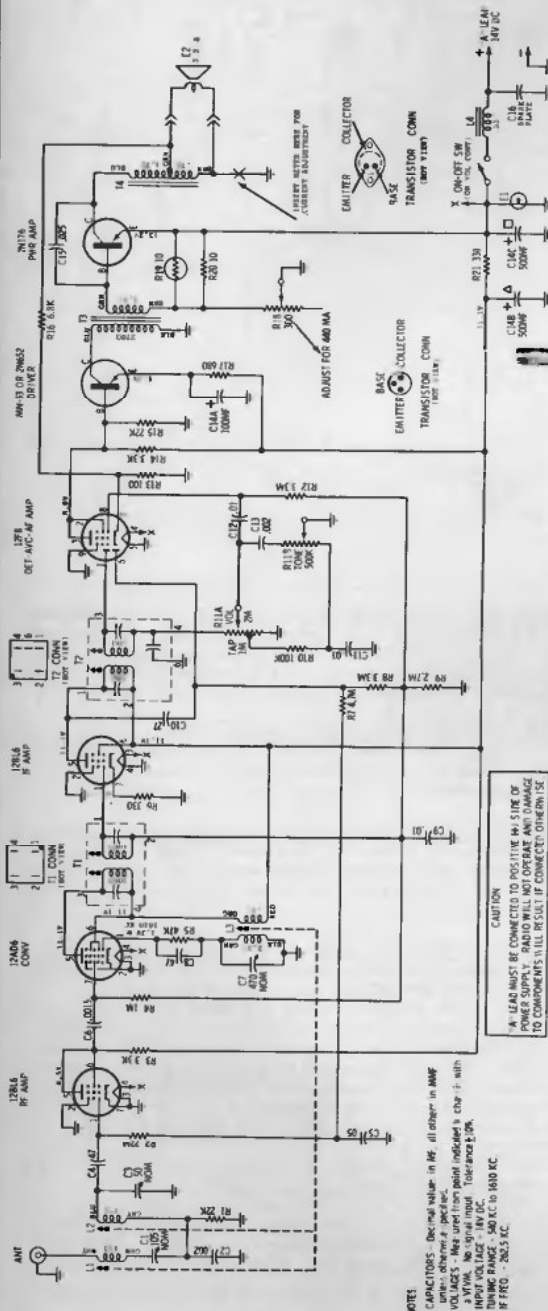

MOTOROLA

AUTO RADIO

MODEL OEA60X

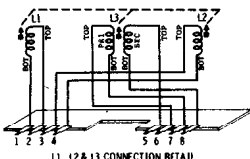

NOTES:
CAPACITORS - Decimal values in MF, all others in MMF unless otherwise specified.
VOLTAGES - Measured from point indicated in chassis with a VTVM. No signal input. Tolerance $\pm 10\%$.
INPUT VOLTAGE - 14V DC.
TUNING RANGE - 540 KC to 1610 KC.
IF FREQ. - 262.5 KC.

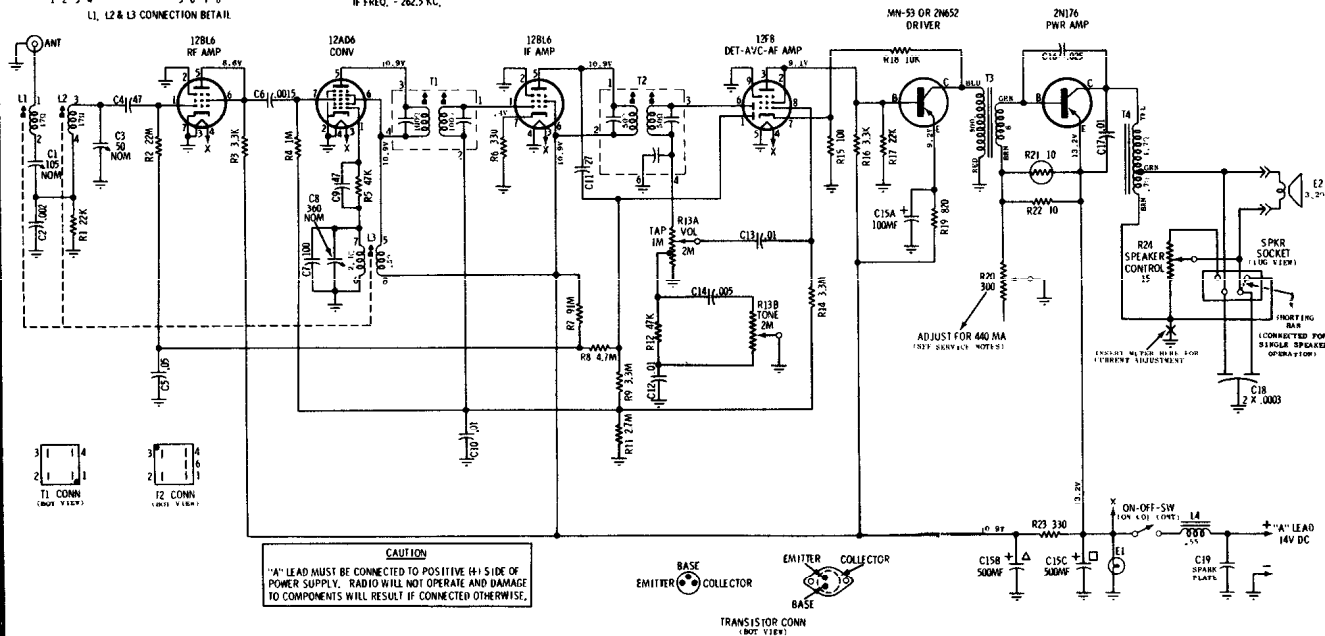
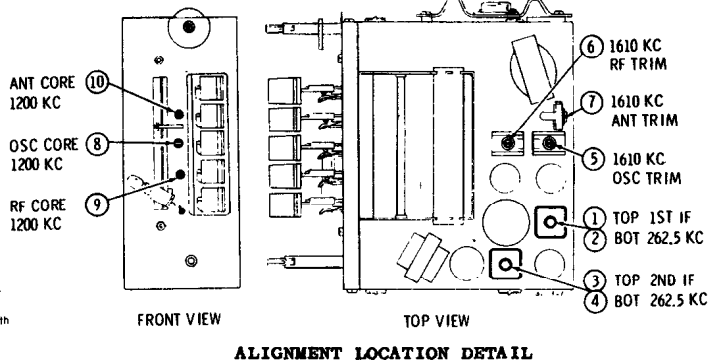

TYPE - Automotive type superheterodyne receiver designed for custom installation in the 1960 Oldsmobile cars.

TO SET PUSHBUTTONS

Pushbuttons may be set up in any order. However, for convenience in remembering, it is suggested that stations be set up in frequency sequence from left to right. During pushbutton set-up, the antenna should be fully extended and antenna trimmer properly peaked at 1400 Kc.

1. Turn receiver on and allow it to operate for fifteen minutes.
2. Unlock pushbuttons by pulling them out with your fingers. In the unlocked position, button will extend about 1/2" forward of its normal position.
3. Accurately tune in station desired for pushbutton setup.
4. Lock one of the pushbuttons to this station by pushing it in firmly.
5. Repeat steps 3 & 4 for remaining pushbuttons

SERVICE NOTES

1. **RADIO POLARITY** - WHEN SERVICING THIS RECEIVER, THE "A" LEAD MUST BE CONNECTED TO THE POSITIVE SIDE OF THE POWER SOURCE. IF CONNECTED OTHERWISE, RECEIVER WILL NOT OPERATE AND DAMAGE TO COMPONENTS MAY RESULT.

2. **POWER SUPPLY REQUIREMENTS** - It is preferable to use a storage battery (without a battery charger) in place of a battery eliminator. If a battery eliminator is used, it must be well regulated and filtered.

3. **POWER TRANSISTOR REPLACEMENT** - When replacing a power transistor, be sure transistor insulator is in place and well greased and that the mounting screws are securely and evenly tightened. Use only the transistor specified in the Replacement Parts List for replacement. See Notes 4 & 6.

4. **POWER TRANSISTOR INSULATOR** - When replacing a power transistor or power transistor insulator, be sure to coat both sides of insulator with DC-4 grease (Motorola Part No. 11M490487) to insure proper heat dissipation.

5. **DRIVER TRANSISTOR REPLACEMENT** - When replacing a driver transistor, grasp the transistor leads (between the transistor body and soldering lug) with a pair of long nose pliers to prevent excessive heating of transistor body during soldering operation.

6. **POWER TRANSISTOR CURRENT ADJUSTMENT** - After a power transistor has been replaced, the collector current should be checked and adjusted for proper operation.
a. Insert a low range (0-1 or 0-2 amp) DC ammeter in the primary ground return lead of the output transformer (T4). Connect the negative post of the meter to ground. CAUTION: Be sure the speaker ground lead is connected in common with the transformer ground lead to the positive meter terminal (see schematic).
b. Turn the radio on and allow it to heat up for about 15 minutes.
c. Adjust R20 for a reading of 360 ma with 12.6 volts input to the radio "A" lead.

NOTE: Two values of radio input voltage are given as a convenience to service personnel in order to accommodate different power sources. The current value stated on the Schematic Diagram is for 14 volts input to the "A" lead.

MOTOROLA

Exact material for MODEL CTA61 used in 1961 Chevrolet cars.

MODEL BKA61 used in 1961 Buick cars is identical electrically.

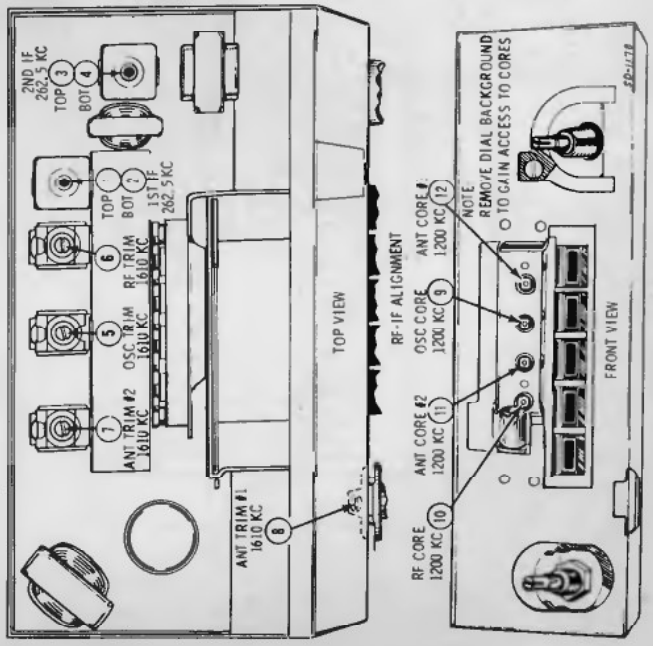
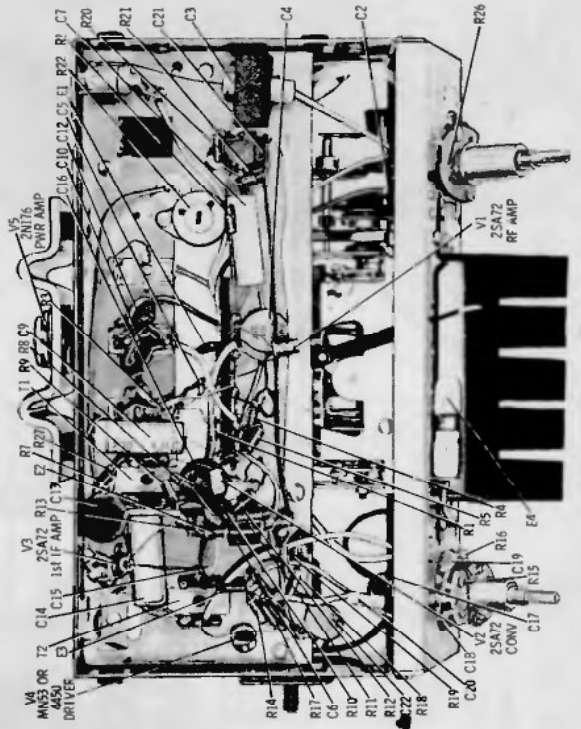
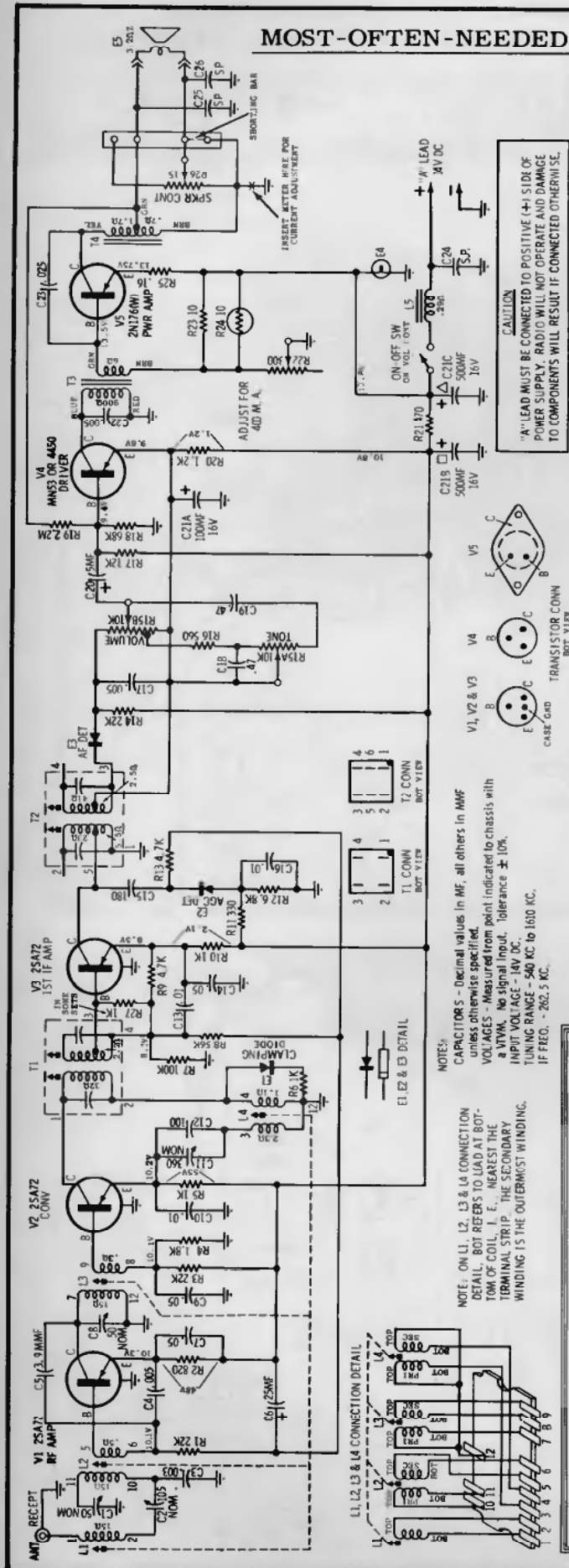

NOTE: ON L1, L2, L3 & L4 CONNECTION DETAIL, BOT REFERS TO LEAD AT BOTTOM OF COIL. I. E., NEAREST THE TERMINAL STRIP. THE SECONDARY WINDING IS THE OUTERMOST WINDING.

NOTE: CAPACITORS - Decimal values in MF, all others in MMF unless otherwise specified.

VOLTAGES - Measured from point indicated to chassis with a VTVM. No signal input. Tolerance $\pm 10\%$.

INPUT VOLTAGE - 14V DC.

TUNING RANGE - 540 KC to 1610 KC.

IF FREQ. - 262.5 KC.

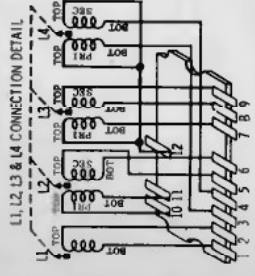

ALIGNMENT LOCATION DETAIL

VOLUME R-21, MOST-OFTEN-NEEDED 1961 RADIO SERVICING INFORMATION

MOTOROLA

MODEL
CTM61X
CTM61XA

Automotive type superheterodyne receivers designed for custom installation in the 1961 Chevrolet cars. Model CTM61X contains a speaker control & socket for adding a rear speaker, model CTM61XA does not; in all other respects, these two receivers are the same.

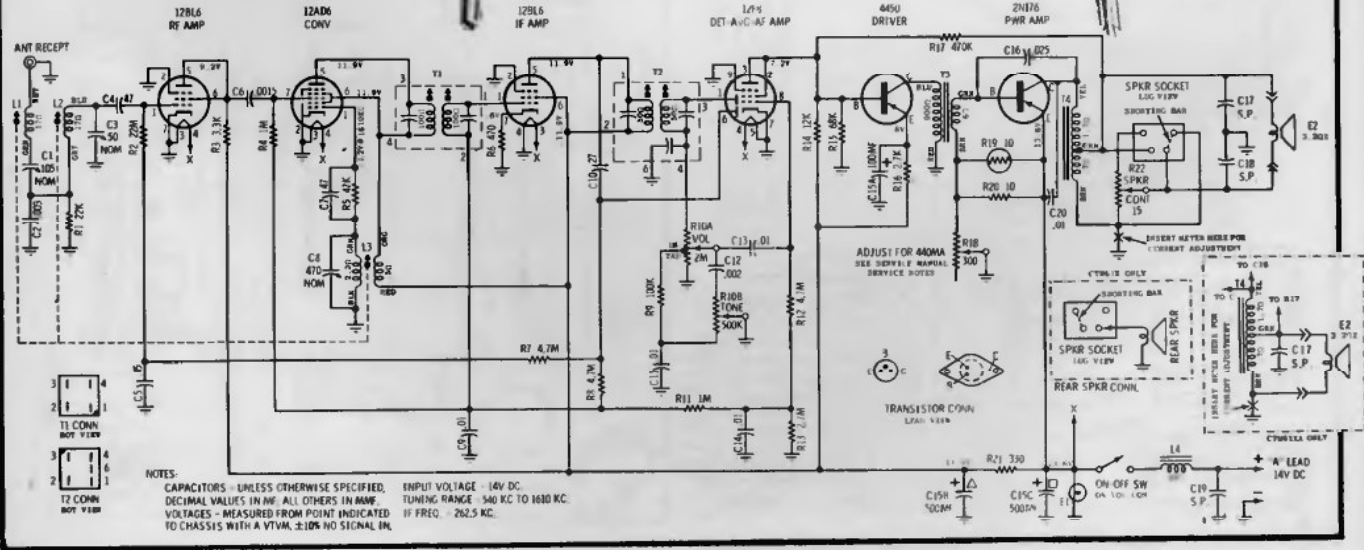
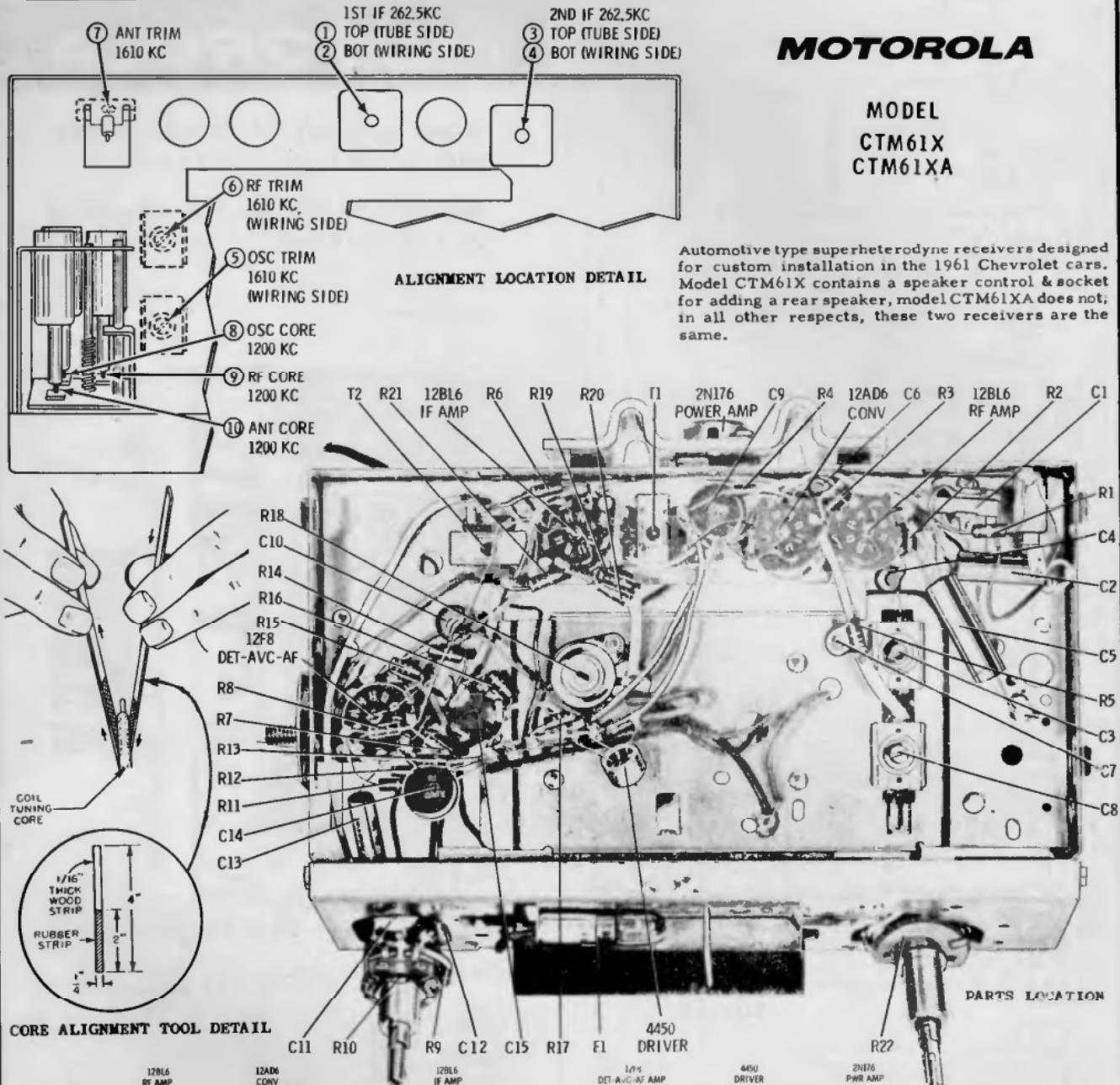

MOTOROLA

MODEL
500X

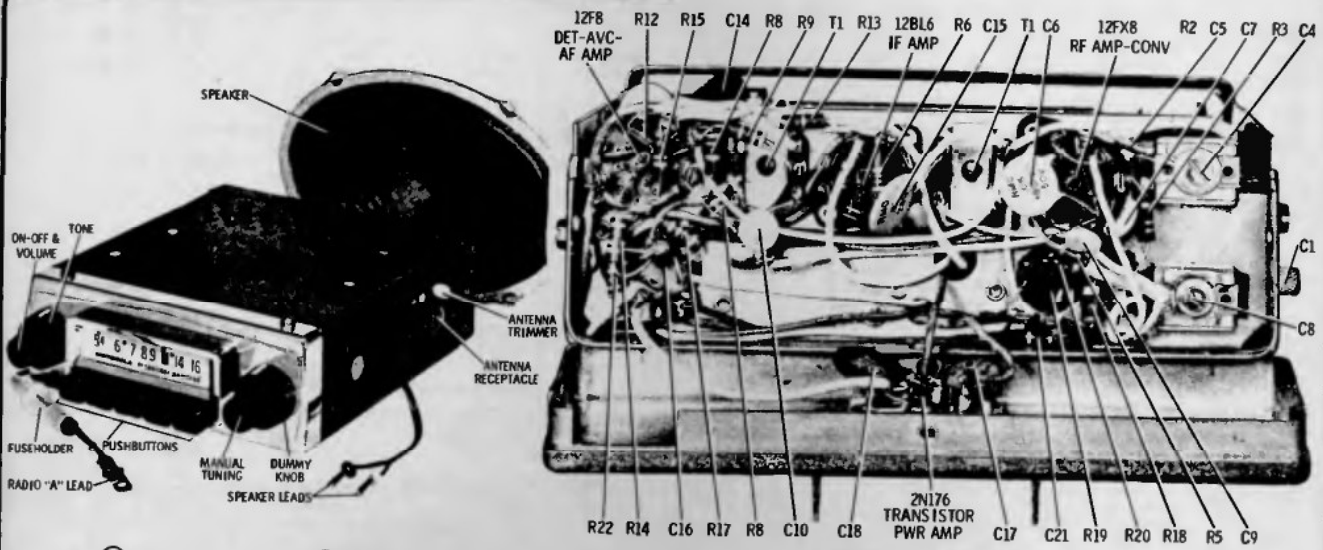

PARTS LOCATION

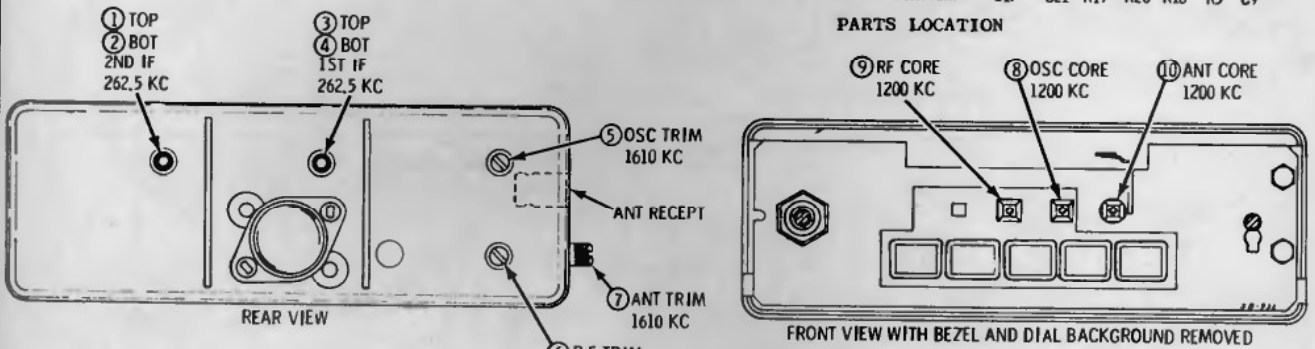

ALIGNMENT POINTS LOCATION DETAIL

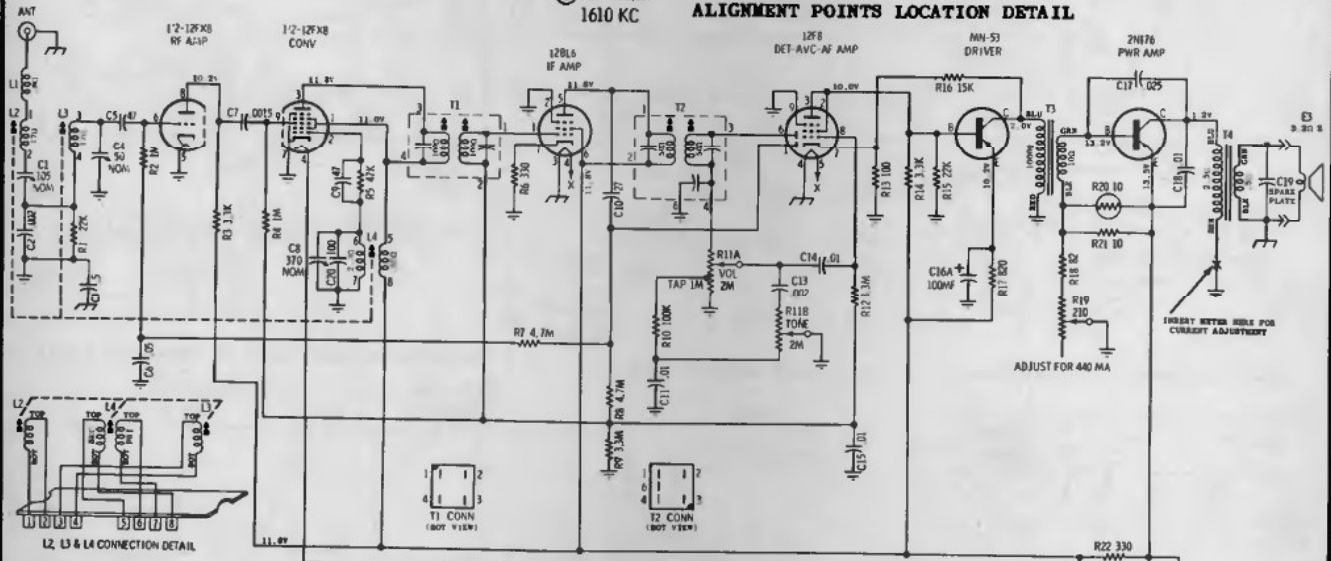

NOTES:
CAPACITORS - Decimik-values on AF, all others in MM unless otherwise specified.
VOLTAGES - Measured from point indicated to chassis with a VTVM. No signal input. $\pm 10\%$.
INPUT VOLTAGE - 14.0V DC.
TUNING RANGE - 535 KC to 1605 KC.
IF FREQ. - 262.5 KC.
- INDICATES ISOLATED NEGATIVE LINE.
- INDICATES CHASSIS AND HOUSING.

CAUTION
BEFORE CONNECTING "A" LEAD, BATTERY POLARITY SHOULD BE CHECKED AND POLARITY REVERSING PLUG SHOULD BE CHANGED CORRESPONDINGLY. OTHERWISE SET WILL NOT OPERATE AND DAMAGE TO COMPONENTS WILL RESULT.

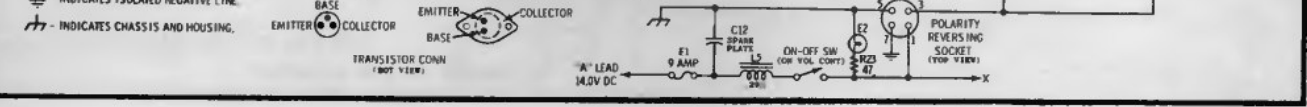

MOTOROLA INC.

Schematic diagram for some models and other service material on the next page, adjacent at right.

MODELS

MoPar	
109	309
111	311
113	314L
114	314V

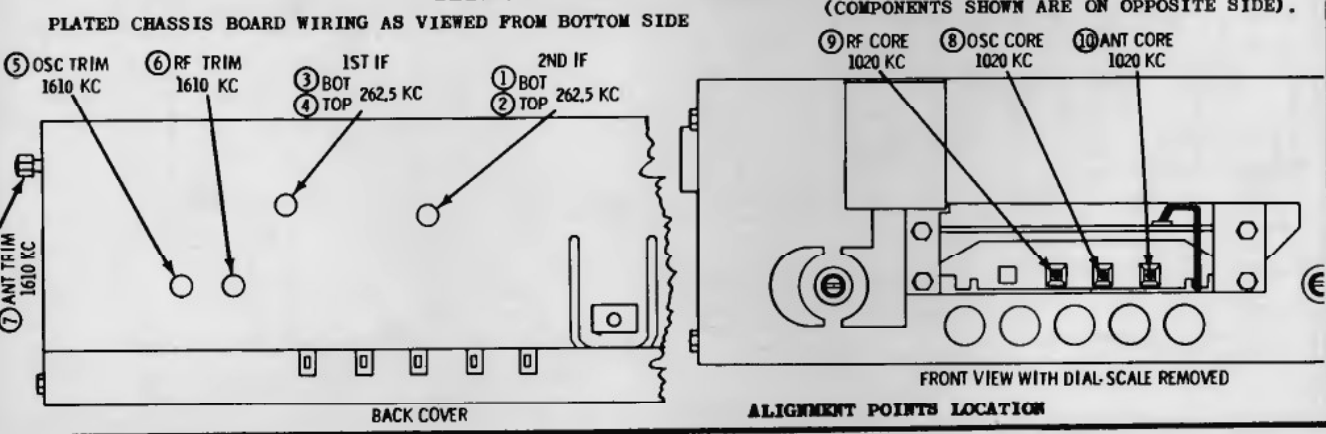
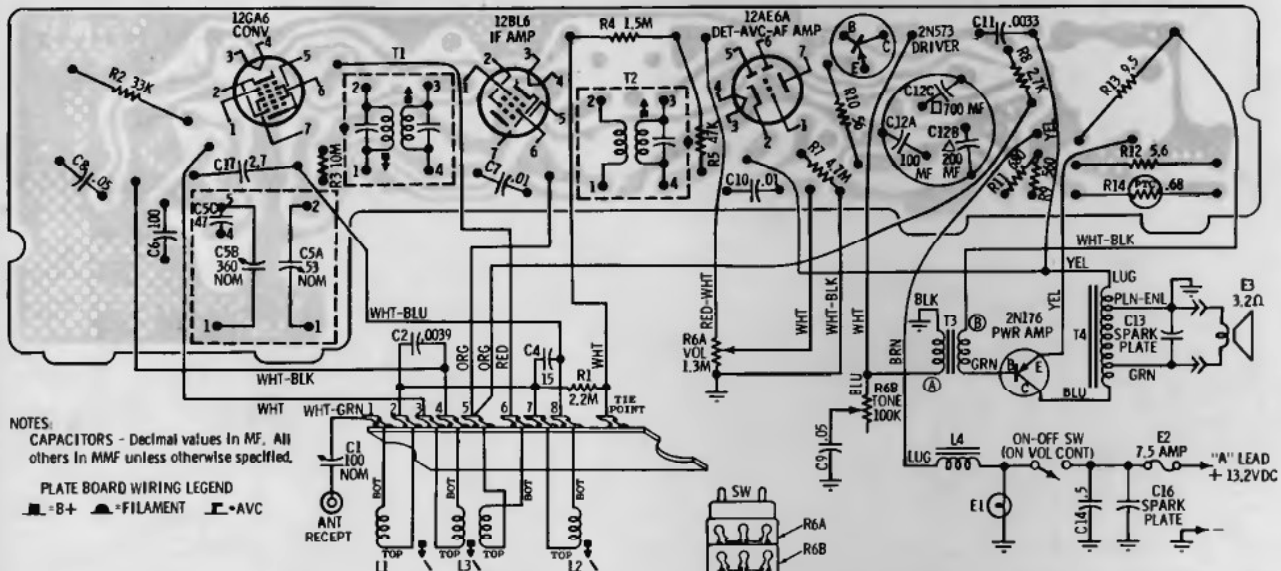
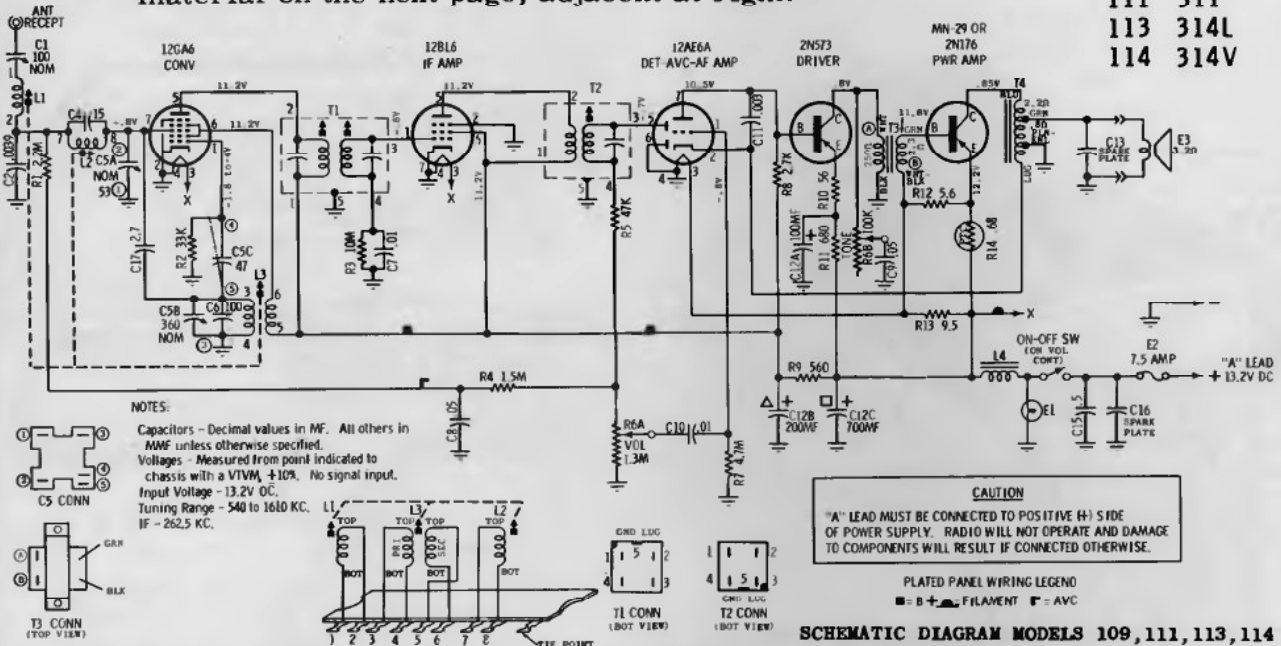

VOLUME R-21, MOST-OFTEN-NEEDED 1961 RADIO SERVICING INFORMATION

MOTOROLA Models 109, 111, 113, 114, 309, 311, 314L, 314V, Continued

PLATED CHASSIS BOARD GROUND CONNECTIONS AS SEEN THRU BOARD FROM WIRING SIDE
MODELS 309, 311, 314L, 314V

NOTES:

CAPACITORS - Decimal values in MF. All others in MMF unless otherwise specified.

PLATE BOARD WIRING LEGEND

-B+ -FILAMENT -AVC

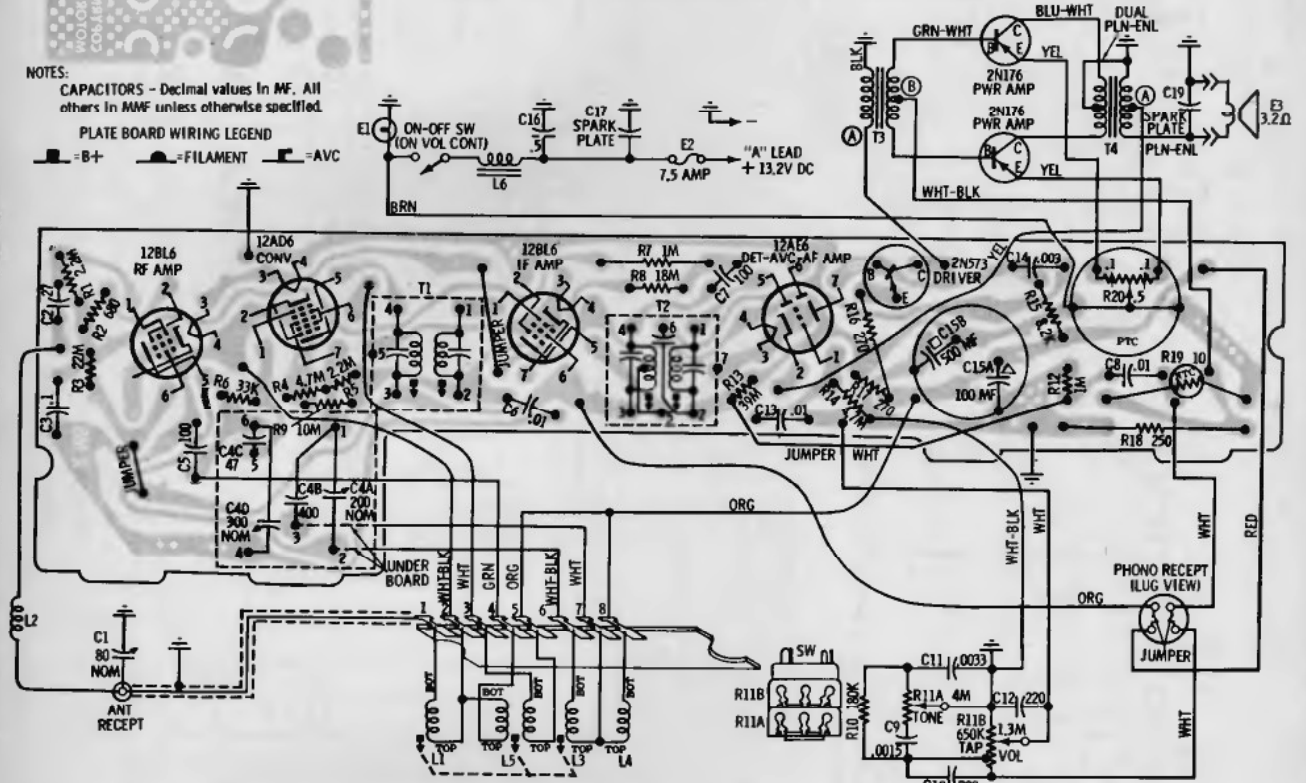

PLATED CHASSIS BOARD WIRING AS VIEWED FROM BOTTOM SIDE (COMPONENTS SHOWN ARE ON OPPOSITE SIDE).

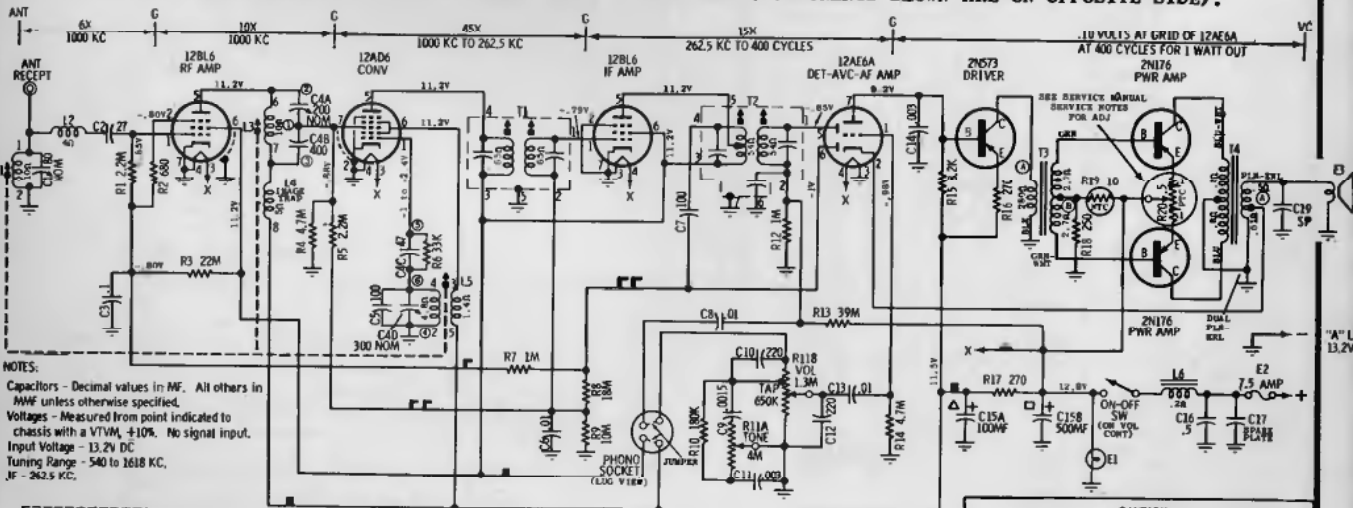

NOTES:

Capacitors - Decimal values in MF. All others in MMF unless otherwise specified.
 Voltages - Measured from point indicated to chassis with a VTVM, $\pm 10\%$. No signal input.
 Input Voltage - 13.2V DC
 Tuning Range - 540 to 1618 KC.
 IF - 262.5 KC.

PLATED PANEL WIRING LEGEND

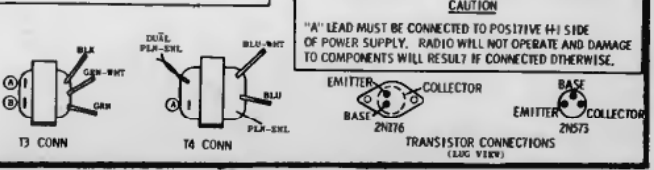
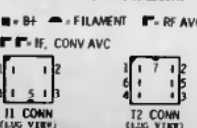

CAUTION
 "A" LEAD MUST BE CONNECTED TO POSITIVE (+) SIDE OF POWER SUPPLY. RADIO WILL NOT OPERATE AND DAMAGE TO COMPONENTS WILL RESULT IF CONNECTED OTHERWISE.

MOTOROLA

MODELS 310X and 311X

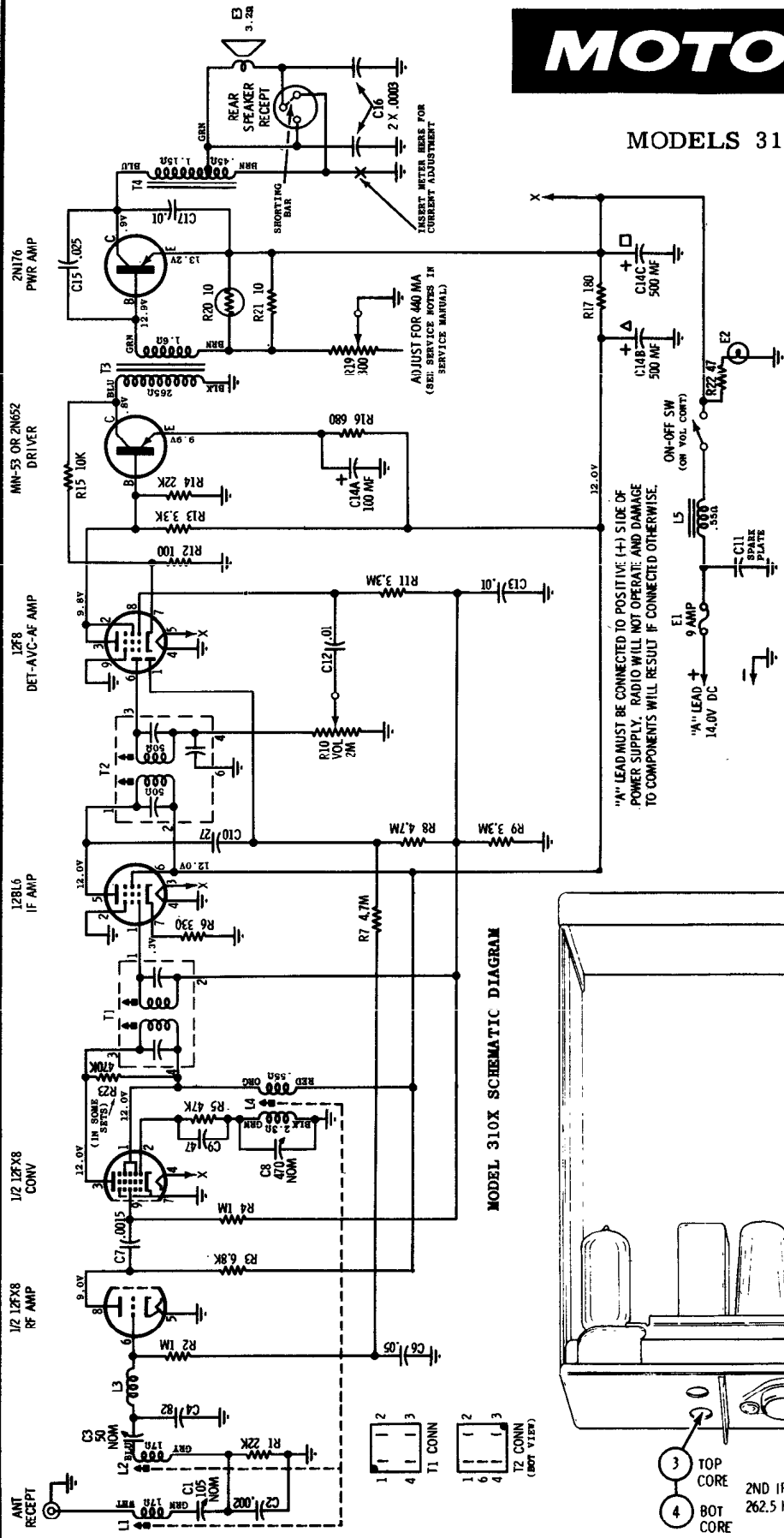

MODEL 310X SCHEMATIC DIAGRAM

POWER TRANSISTOR INSULATOR - When replacing a power transistor or power transistor insulator, be sure to coat both sides of insulator with DC-4 grease (Motorola Part No. 11M490487) to insure proper heat dissipation.

MOTOROLA INC.

MODELS 310X and 311X

Schematic diagram of 310X is on this page, all diagram of 311X is on the next page, all other service material applicable to both.

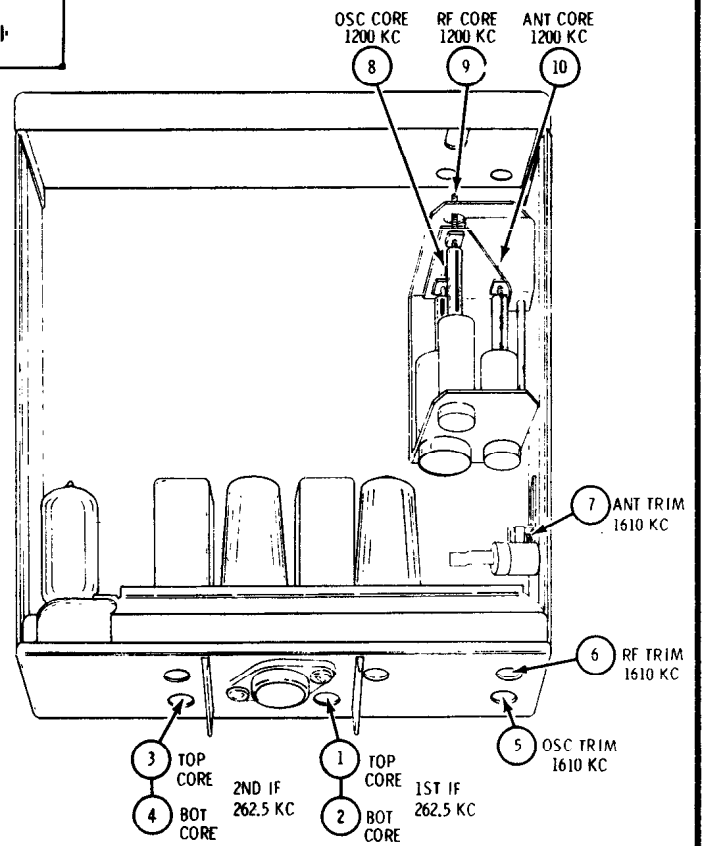

ALIGNMENT POINTS LOCATION

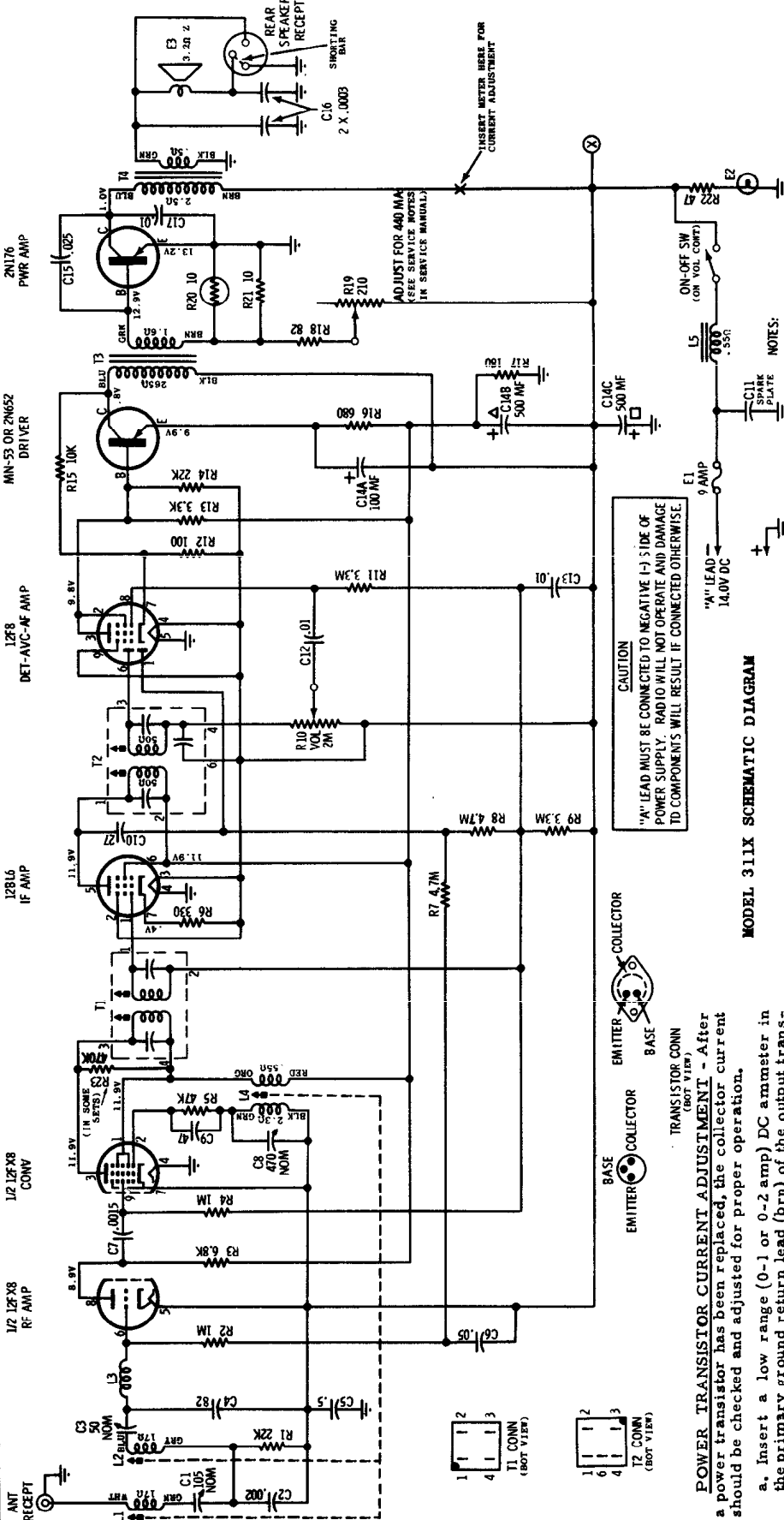

NOTES:
 CAPACITORS - Decimal values in MF, all others in MMF unless otherwise specified.
 VOLTAGES - Measured from point indicated to ⊕ with a VTVM. No signal input. Tolerance ± 10%.
 INPUT VOLTAGE - 14.0V DC.
 TUNING RANGE - 540 KC to 1610 KC.
 IF FREQ. - 262.5 KC.

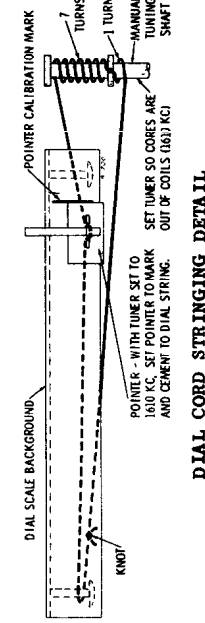

MODEL 311X SCHEMATIC DIAGRAM

Automotive type 12 volt superheterodyne receivers designed for universal underdash installation in most cars. Model 310X is for use with cars having a negative ground electrical system. Model 311X is for use with cars having a positive ground electrical system.

Circuit diagram of 311X is above, and 310X is on preceding page.

MOTOROLA INC.

MODELS
 310X & 311X

CAUTION
 "A" LEAD MUST BE CONNECTED TO NEGATIVE (-) SIDE OF POWER SUPPLY. RADIO WILL NOT OPERATE AND DAMAGE TO COMPONENTS WILL RESULT IF CONNECTED OTHERWISE.

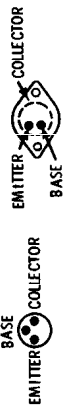

POWER TRANSISTOR CURRENT ADJUSTMENT - After a power transistor has been replaced, the collector current should be checked and adjusted for proper operation.

- Insert a low range (0-1 or 0-2 amp) DC ammeter in the primary ground return lead (brn) of the output transformer (T4). See Schematic.
- NOTE: In model 310X, connect both the transformer and speaker ground leads to the positive terminal of the meter; connect the negative meter terminal to chassis.
- In model 311X, connect the positive meter terminal to the brown transformer lead and negative meter terminal to the ON-OFF switch terminal.

- Turn the radio on and allow it to heat up for about 15 minutes.
- Adjust R19 for a reading of 360 ma with 12.6 volts input to the radio "A" lead.

NOTE: Two values of radio input voltage are given as a convenience to service personnel in order to accommodate different power sources. The current value stated on the Schematic Diagram is for 14 volts input to the radio "A" lead.

VOLUME R-21, MOST-OFTEN-NEEDED 1961 RADIO SERVICING INFORMATION

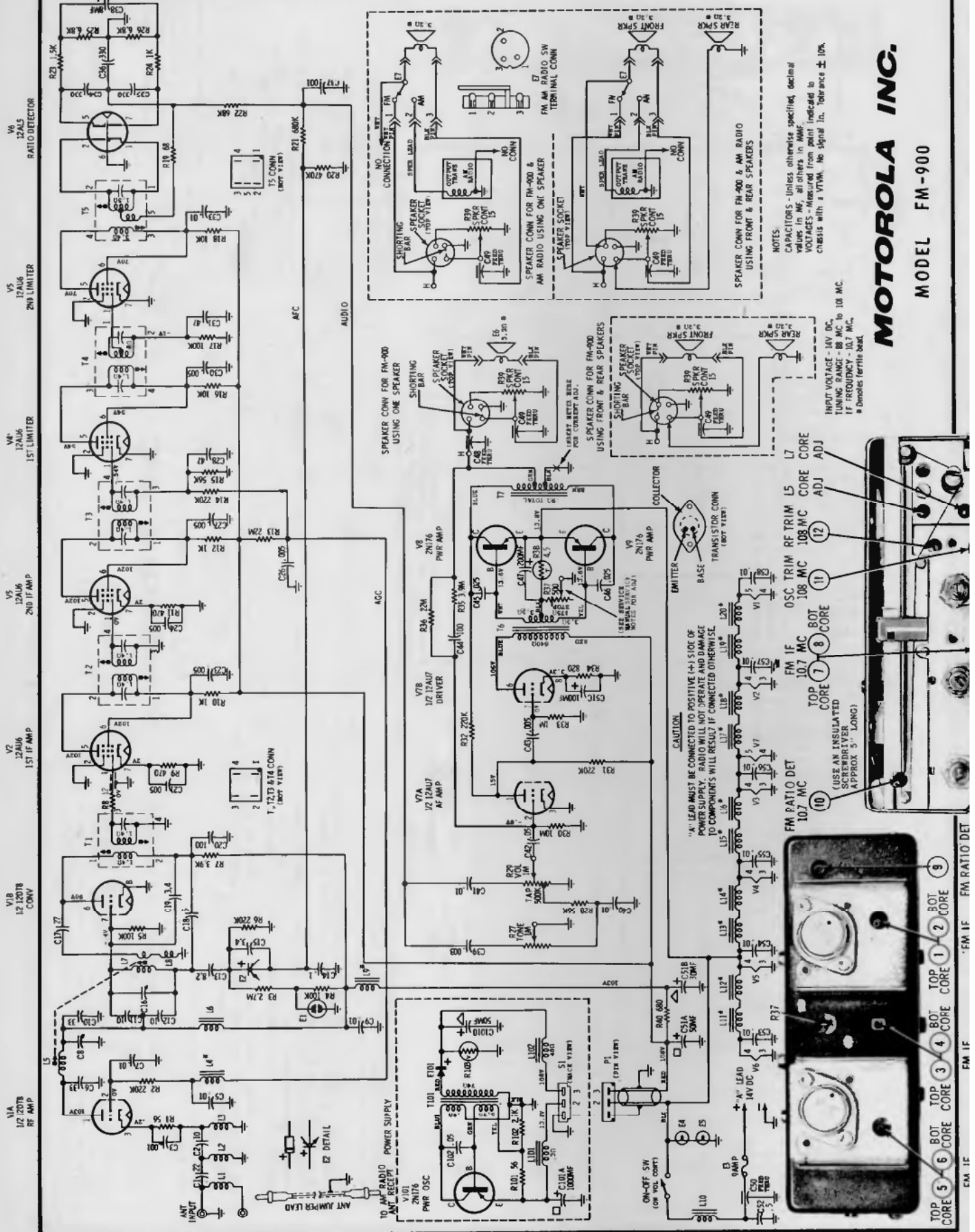

MOTOROLA INC.
MODEL FM-900

MOTOROLA

MODELS
A3B, N
CHASSIS
HS-746

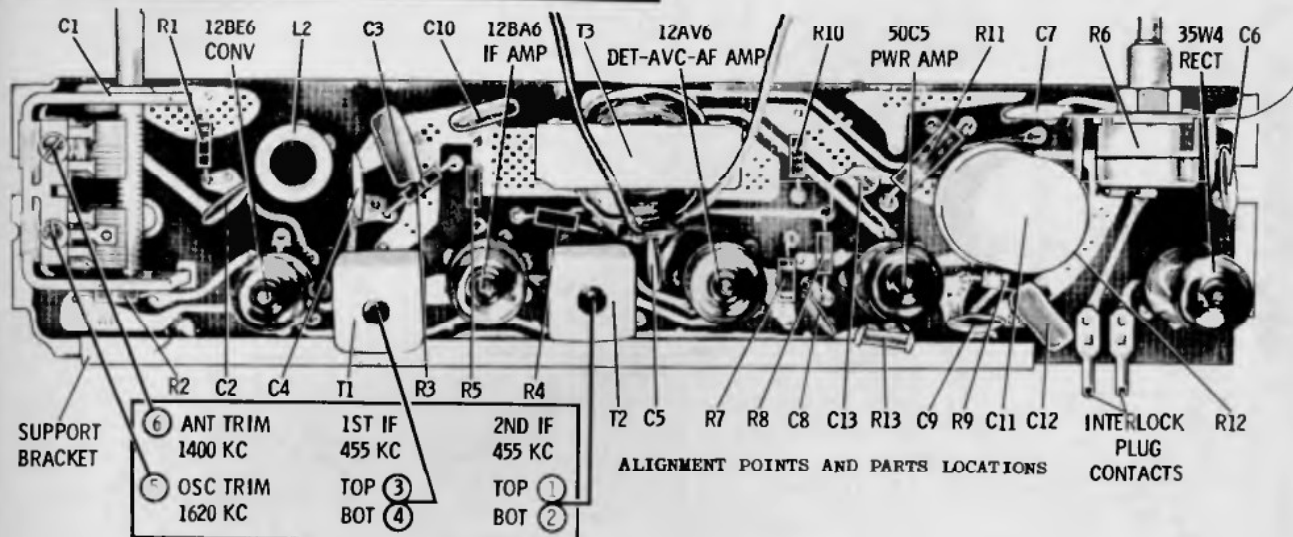

ALIGNMENT

Use an isolation transformer between the power line and the receiver. If not available, connect low side of generator to B- through a .1 mf capacitor. Connect a low range output meter across speaker voice coil and set volume control to maximum. Attenuate generator output to maintain .4 volts on output meter to prevent overloading the receiver.

STEP	GENERATOR CONNECTION	GENERATOR FREQUENCY (400 cycle mod)	GANG SETTING	ADJUST	REMARKS
1.	IF ALIGNMENT 12BE6 grid (pin 7) thru .1 mf & B-	455 Kc	Fully open	1, 2, 3 & 4	Adjust for maximum.
2.	RF ALIGNMENT Radiation loop*	1620 Kc	Fully open	5	Adjust for maximum.
3.	"	1400 Kc	Tune for max	6	"

*Connect generator output across 5" diameter, 5 turn loop and couple inductively to receiver loop. Keep radiation loop at least 12" from receiver loop.

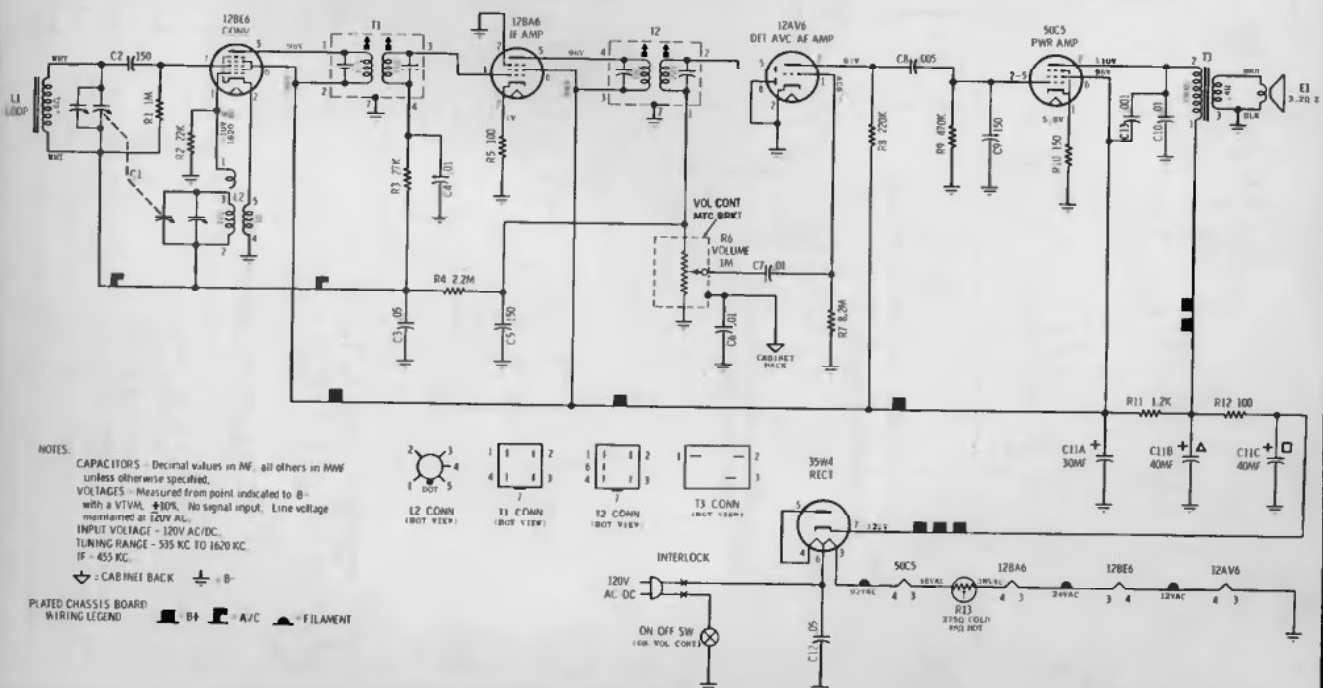

MOTOROLA INC.

MODELS
SK32W
SK33W
SK35W
SK39MB

CHASSIS
HS-775, 776
HS-775, 776
HS-776, 778
HS-776, 778

(Continued on the next page)

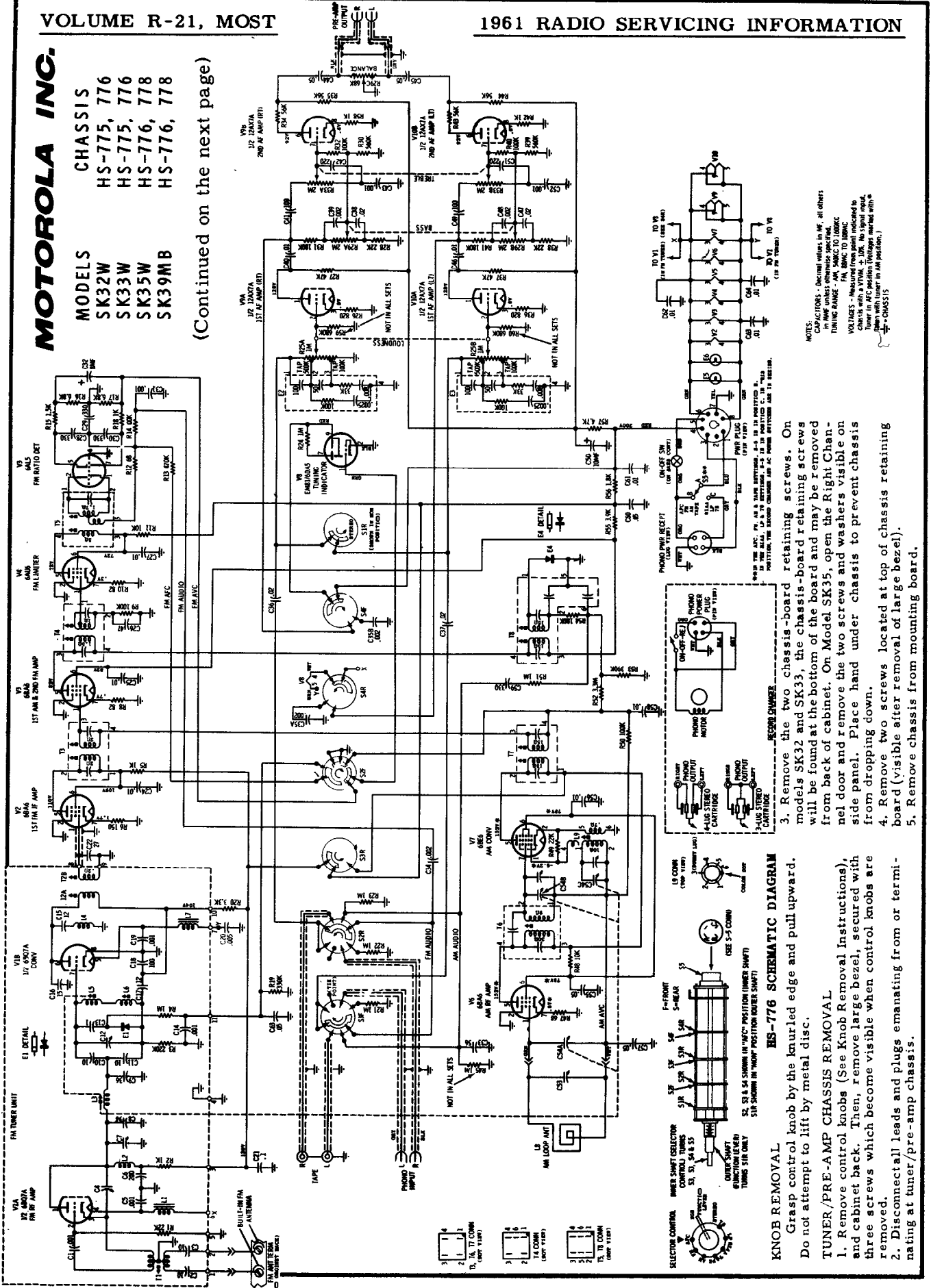

NOTES:
1. Values in parentheses in AM, all others in AM unless otherwise indicated.
2. Tuning range - AM, SK32C TO SK32W; FM, SK33C TO SK33W.
3. Values in parentheses in FM, all others in FM unless otherwise indicated.
4. Values in parentheses in FM, all others in FM unless otherwise indicated.
5. Values in parentheses in FM, all others in FM unless otherwise indicated.
6. Values in parentheses in FM, all others in FM unless otherwise indicated.
7. Values in parentheses in FM, all others in FM unless otherwise indicated.
8. Values in parentheses in FM, all others in FM unless otherwise indicated.
9. Values in parentheses in FM, all others in FM unless otherwise indicated.
10. Values in parentheses in FM, all others in FM unless otherwise indicated.

3. Remove the two chassis-board retaining screws. On models SK32 and SK33, the chassis-board retaining screws will be found at the bottom of the board and may be removed from back of cabinet. On Model SK35, open the Right Channel door and remove the two screws and washers visible on side panel. Place hand under chassis to prevent chassis from dropping down.
4. Remove two screws located at top of chassis retaining board (visible after removal of large bezel).
5. Remove chassis from mounting board.

HS-776 SCHEMATIC DIAGRAM

KNOB REMOVAL
Grasp control knob by the knurled edge and pull upward. Do not attempt to lift by metal disc.

TUNER/PRE-AMP CHASSIS REMOVAL
1. Remove control knobs (See Knob Removal Instructions), and cabinet back. Then, remove large bezel, secured with three screws which become visible when control knobs are removed.

2. Disconnect all leads and plugs emanating from or terminating at tuner/pre-amp chassis.

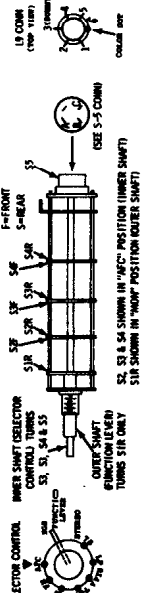

MOTOROLA

(Continued from preceding page)

MODELS	CHASSIS
SK32W	HS-775, 776
SK33W	HS-775, 776
SK35W	HS-776, 778
SK39M B	HS-776, 778

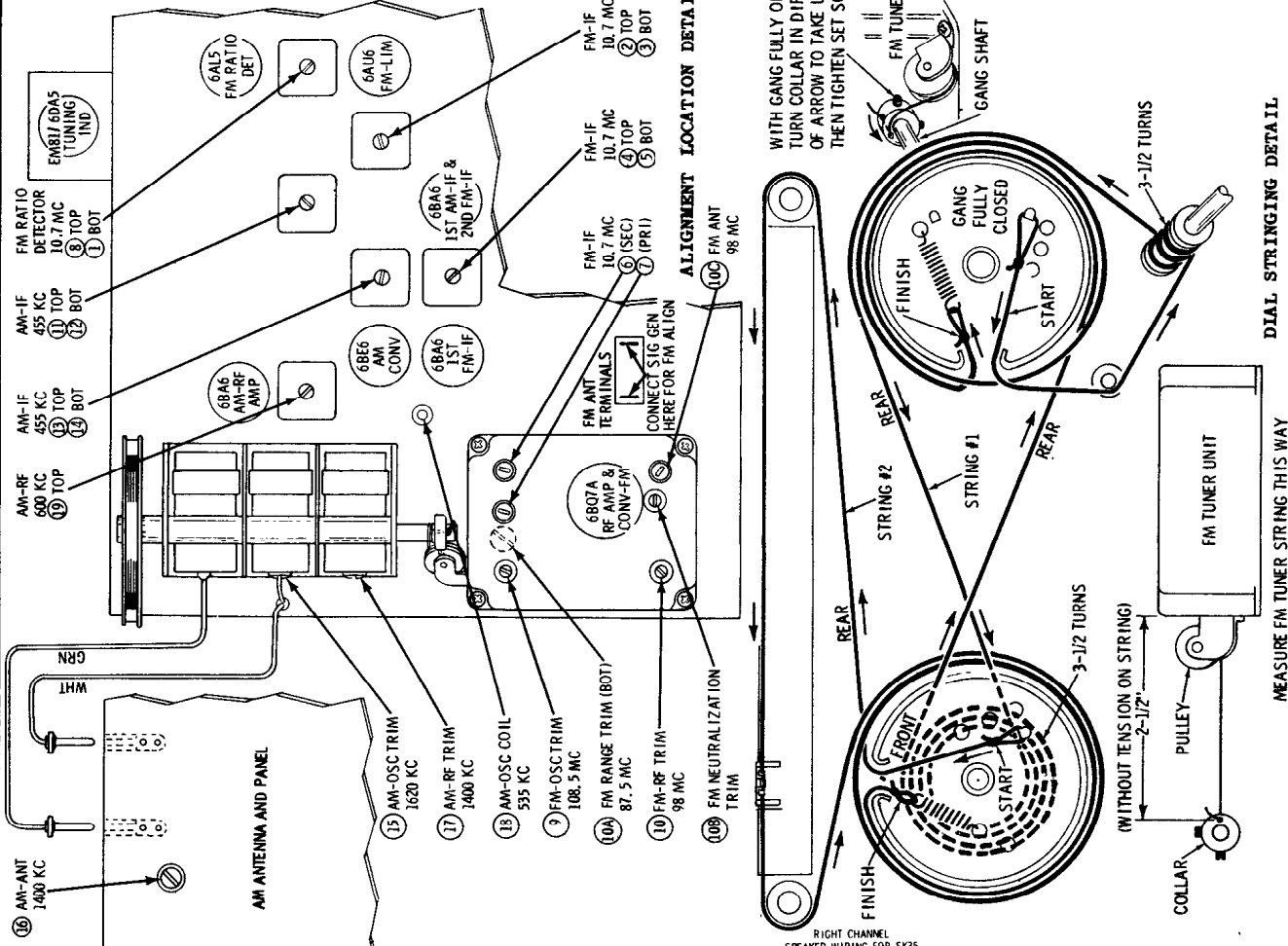

WITH GANG FULLY OPEN, TURN COLLAR IN DIRECTION OF ARROW TO TAKE UP SLACK, THEN TIGHTEN SET SCREWS.

ALIGNMENT LOCATION DETAIL

DIAL STRINGING DETAIL

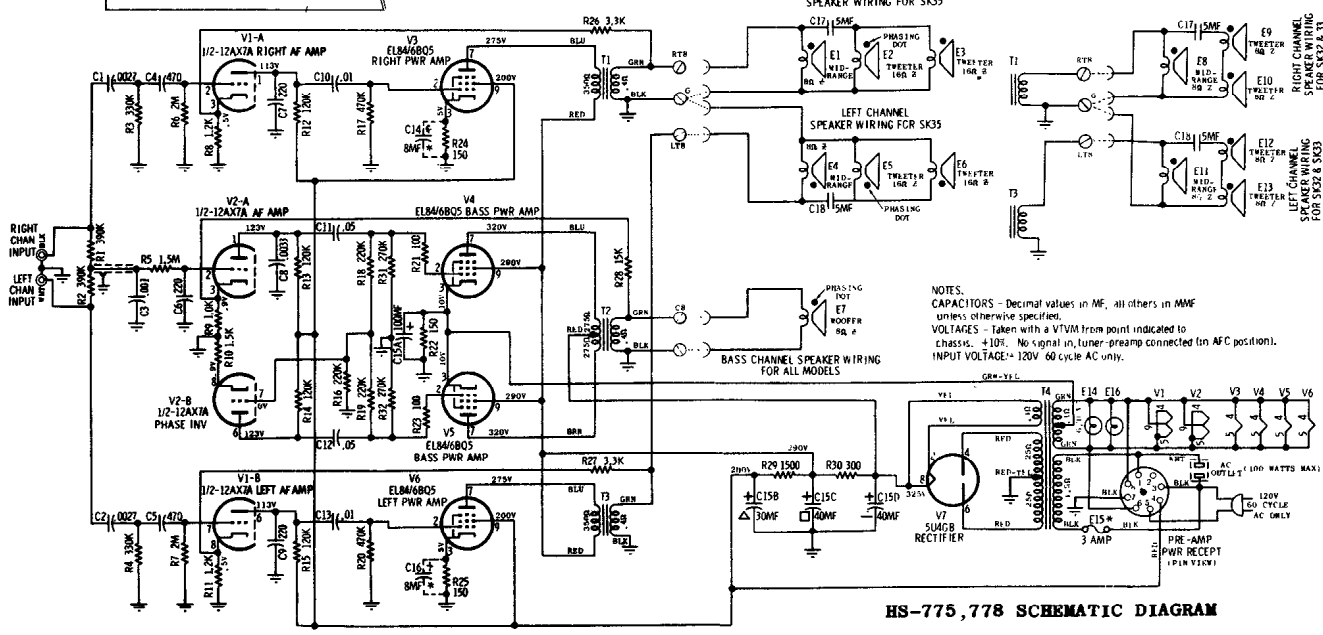
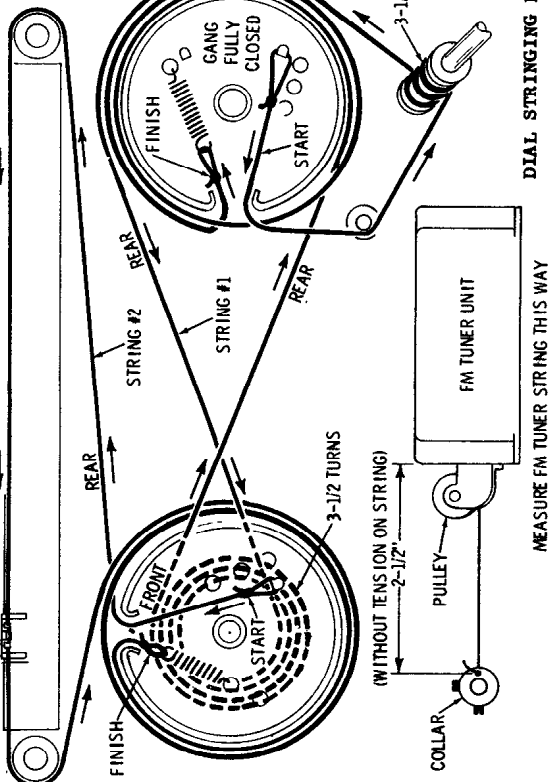

HS-775, 778 SCHEMATIC DIAGRAM

NOTES:
CAPACITORS - Decimal values in MF, all others in MMF unless otherwise specified.
VOLTAGES - Taken with a VTVM from point indicated to chassis. +10%. No signal in tuner-preamp connected (in AFC position).
INPUT VOLTAGE = 120V 60 cycle AC only.

MOTOROLA

PORTABLE RADIO

MODEL	CHASSIS
X14B	HS-795
X14E	HS-795
X14R	HS-795
X14W	HS-795

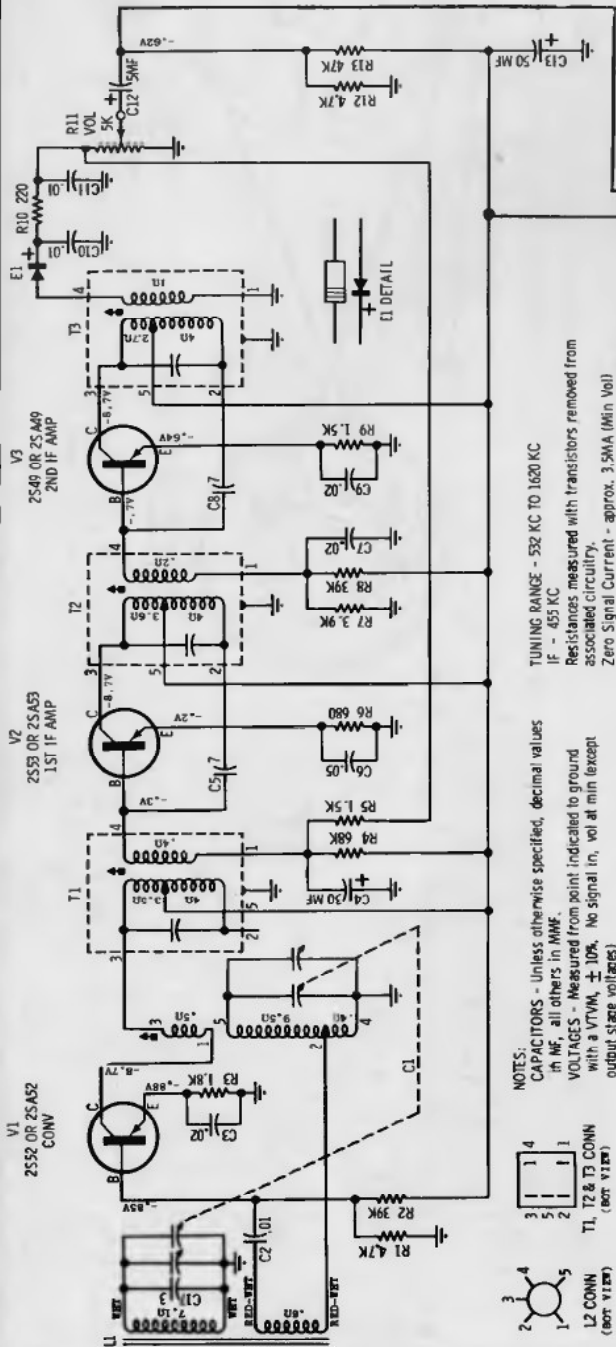

TUNING RANGE - 532 KC TO 1620 KC
IF - 455 KC
Resistances measured with transistors removed from associated circuitry.
Zero Signal Current - approx. 3.5mA (Min Vol)

NOTES:
CAPACITORS - Unless otherwise specified, decimal values in μ F, all others in MMF.
VOLTAGES - Measured from point indicated to ground with a VTVM, $\pm 10\%$. No signal in, vol at min (except output stage voltages).

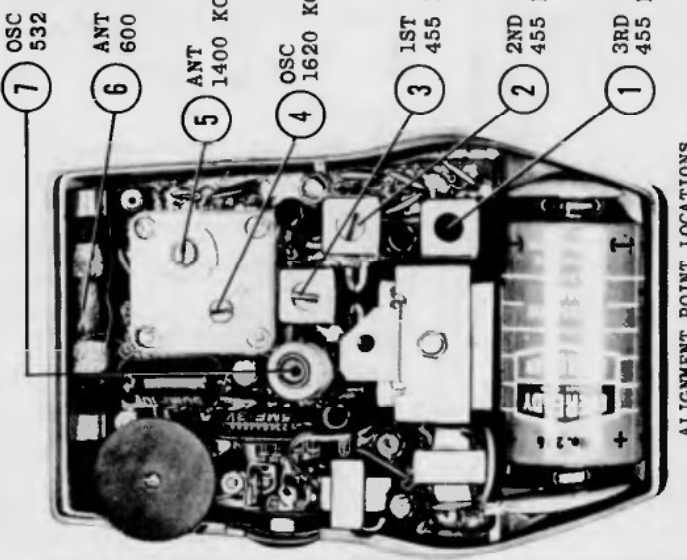
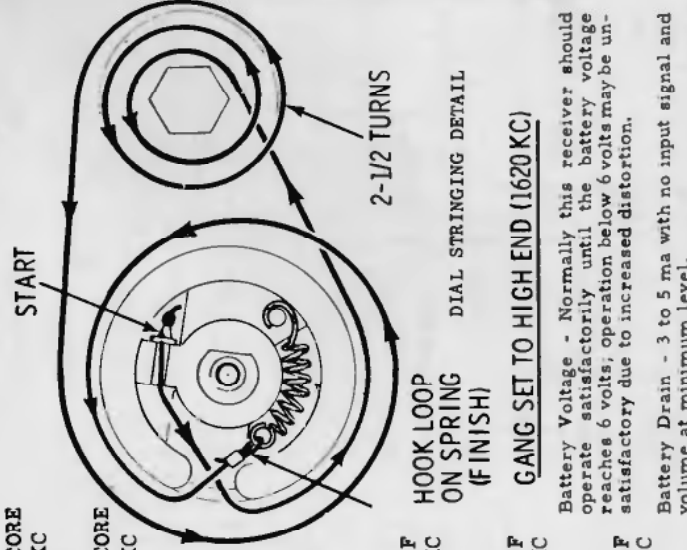
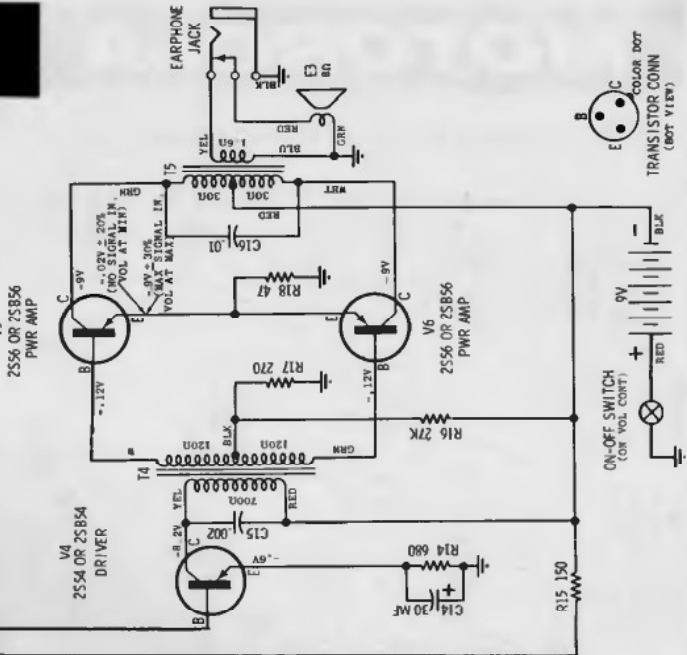
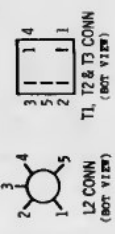

Battery Voltage - Normally this receiver should operate satisfactorily until the battery voltage reaches 6 volts; operation below 6 volts may be unsatisfactory due to increased distortion.
Battery Drain - 3 to 5 ma with no input signal and volume at minimum level.

ALIGNMENT POINT LOCATIONS

MOTOROLA INC.

MODEL	CHASSIS
X15A	HS-796
X15E	HS-796
X15N	HS-796

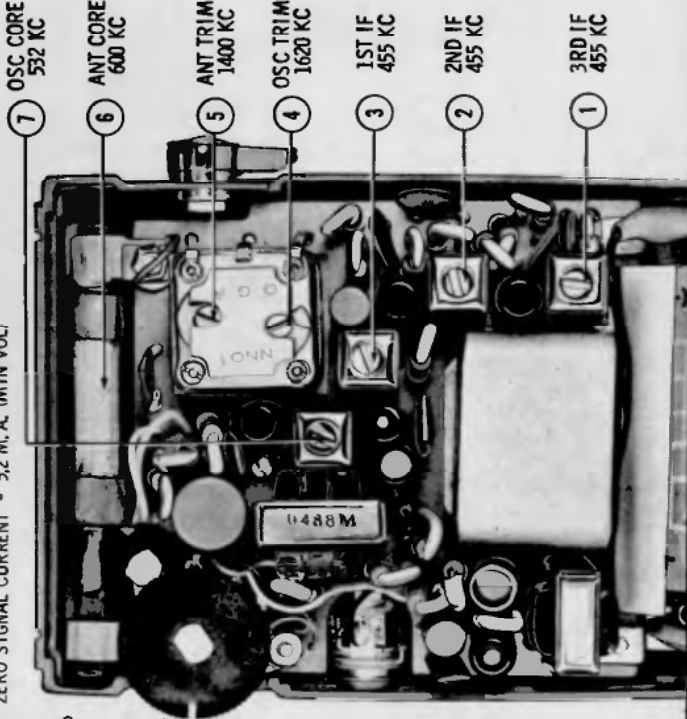
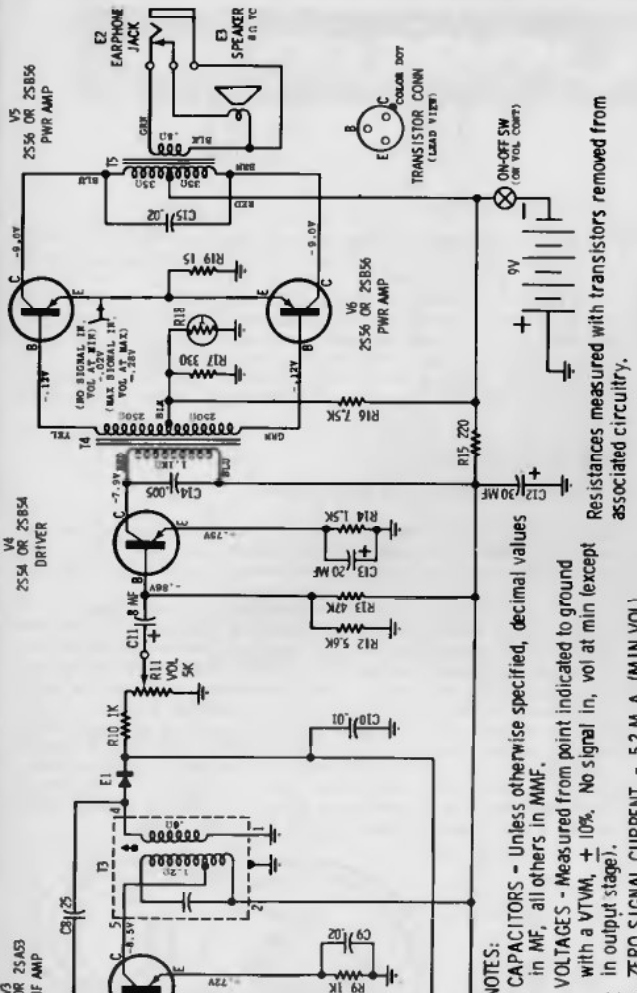

RESISTANCES MEASURED WITH TRANSISTORS REMOVED FROM ASSOCIATED CIRCUITRY.

NOTES:
 CAPACITORS - Unless otherwise specified, decimal values in MF, all others in MMF.
 VOLTAGES - Measured from point indicated to ground with a VTVM, $\pm 10\%$. No signal in, vol at min (except in output stage).
 ZERO SIGNAL CURRENT - 5.2 M. A. (MIN VOL)

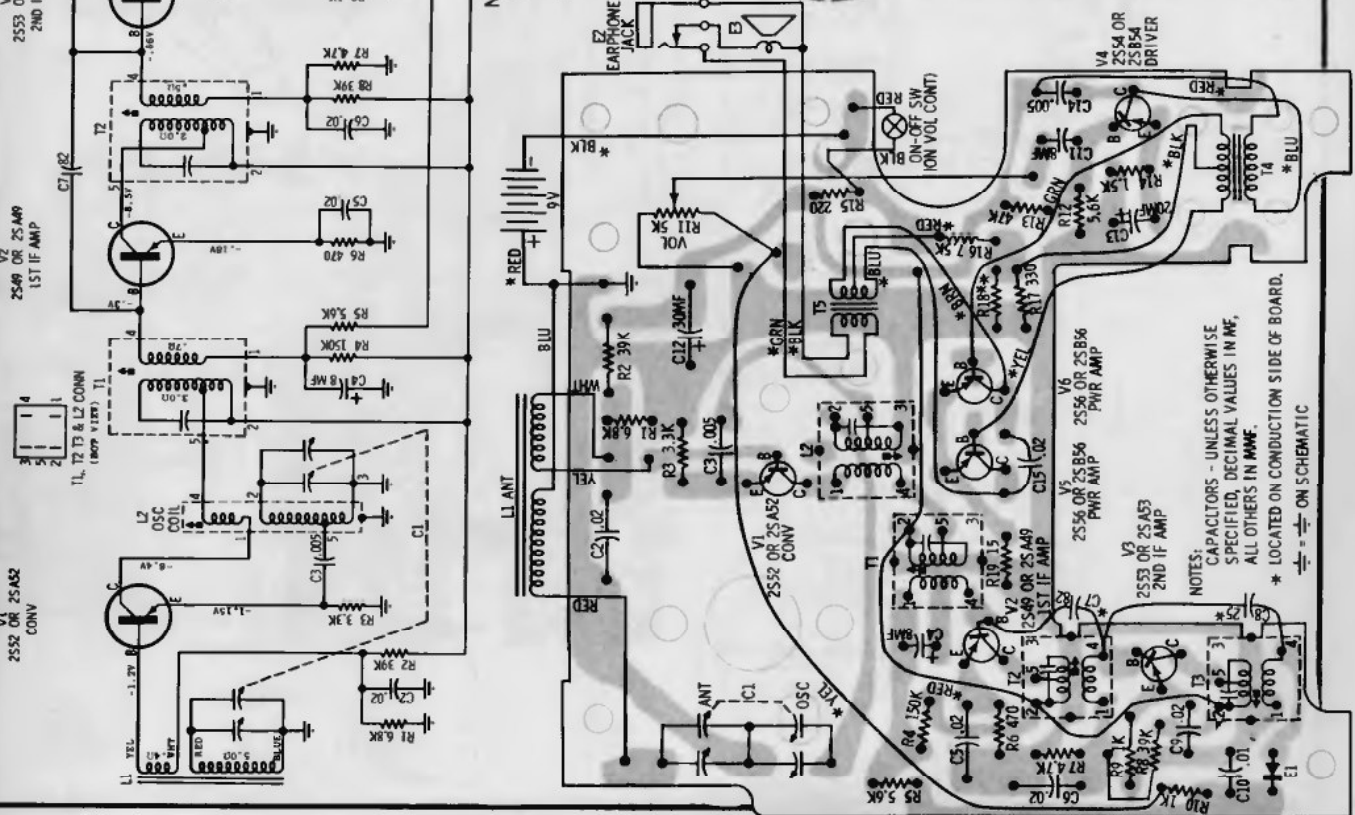

NEEDED 1961 RADIO SERVICING INFORMATION

MOTOROLA INC.

MODEL	CHASSIS
X16B	HS-797
X16G	HS-797
X16N	HS-797

CHASSIS REMOVAL

1. Rotate cabinet handle to its carrying position.
2. Loosen captivated back panel mounting screw completely and remove back panel.
3. Remove cabinet back mounting screw and cabinet back.
4. Remove carrying handle and On-Off and Volume knob.
5. Remove 3 chassis mounting screws (in doing so, the cabinet back mounting bracket will also come out).
6. Remove chassis from cabinet (lift up right side of chassis first, to allow the tuning knob to clear its cutout on the cabinet).

BATTERY DRAIN

10-14 ma (max) with no input signal

NOTE: Due to the type of circuitry involved, there are two separate battery current paths, therefore, a DPST on-off switch is used. This necessitates two current measurements.

A very simple, convenient method of measuring battery drain can be made without unsoldering any connections. The only items necessary are a low resistance DC milliammeter and a jumper wire or two milliammeters. With the receiver turned off, place a milliammeter across the open terminals of one section of the switch and the jumper across the other section of the switch; the receiver is automatically turned on at the minimum volume level. The meter should read 10-14 ma; then interchange jumper wire and milliammeter connections, the meter should read 10-14 ma. If two milliammeters are available, place one across each section of the switch; each meter should read 10-14 ma.

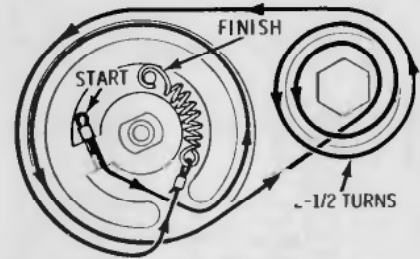

GANG SET TO HIGH END (1620 KC)

NOTES:
 CAPACITORS - Unless otherwise specified, decimal values in MF, all others in MMF.
 VOLTAGES - Measured from point indicated to ground or across points indicated with a VTVM. $\pm 10\%$ No signal in.
 - ground
 Zero Signal Current - approx. 12 MA (Main Volu)
 TUNING RANGE - 515 KC to 1620 KC
 IF - 455 KC
 Resistances measured with transistors removed from associated circuitry.

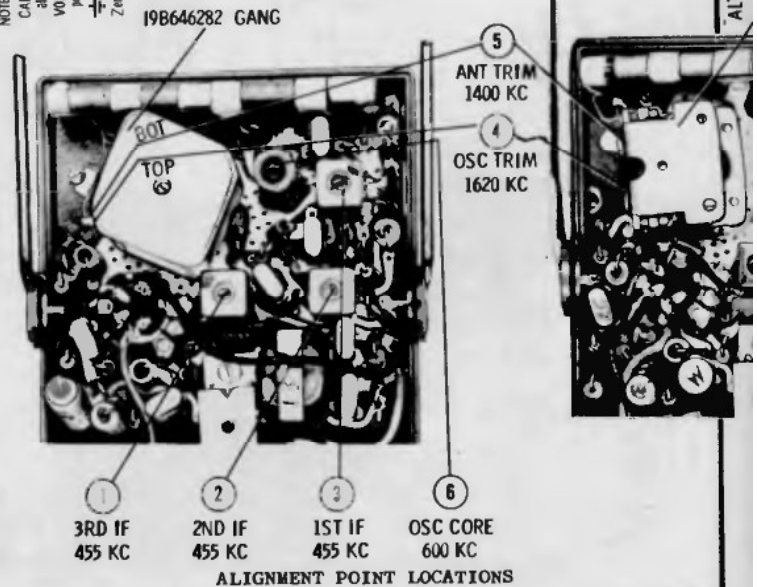

ALIGNMENT POINT LOCATIONS

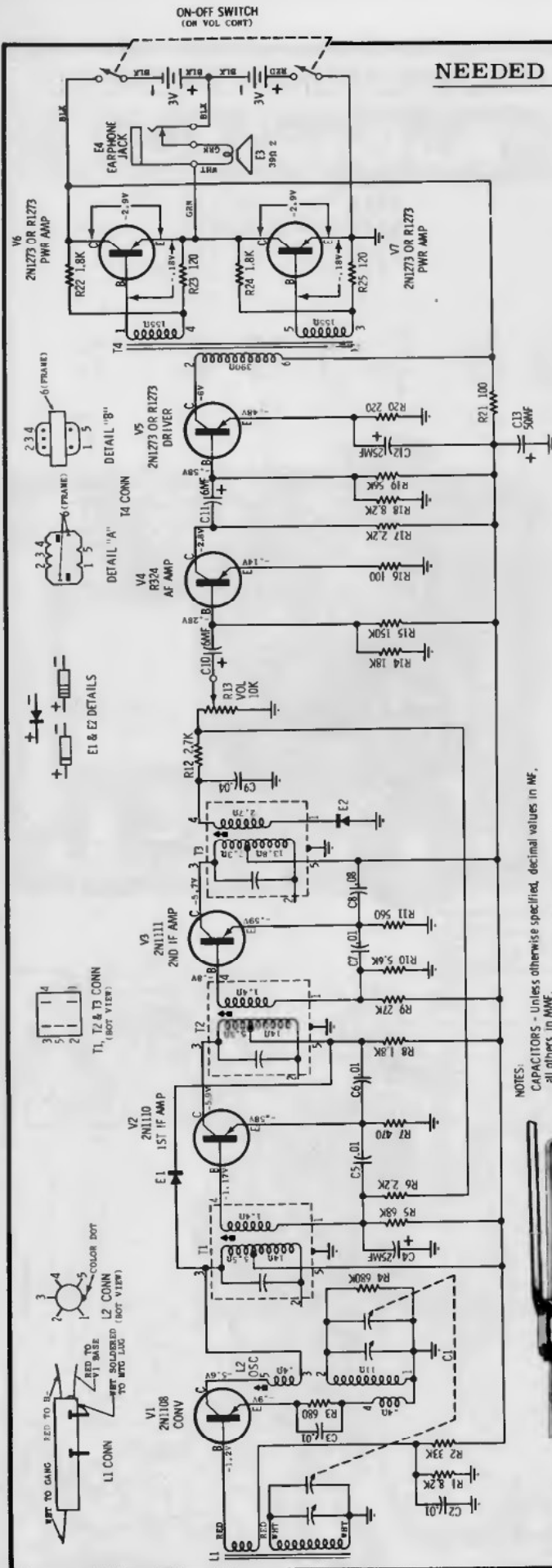



MODEL	CHASSIS
X17B	HS-798
X17N	HS-798
X17R	HS-798

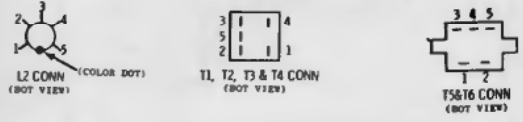
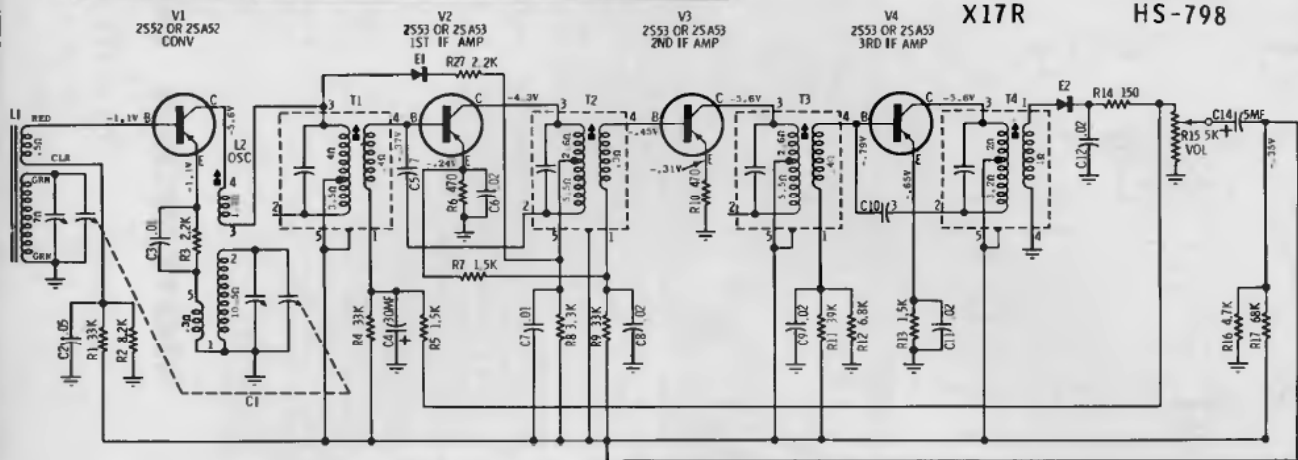

NOTES:
 CAPACITORS - Unless otherwise specified, decimal values in MF, all others in MMF.
 VOLTAGES - Measured from point indicated to ground with a VTVM, $\pm 10\%$. No signal in.
 TUNING RANGE - 535 KC to 1620 KC.
 IF - 455 KC.
 Resistances measured with transistors removed from associated circuitry.
 Zero signal current = 7.0MA (Min Vol)
 \perp = Ground

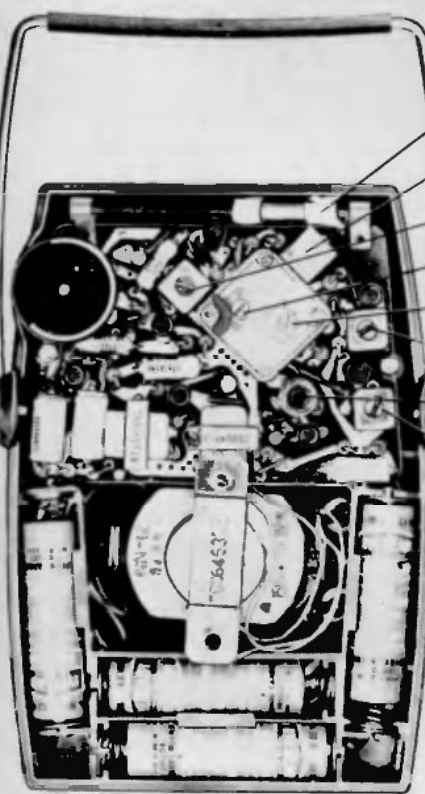
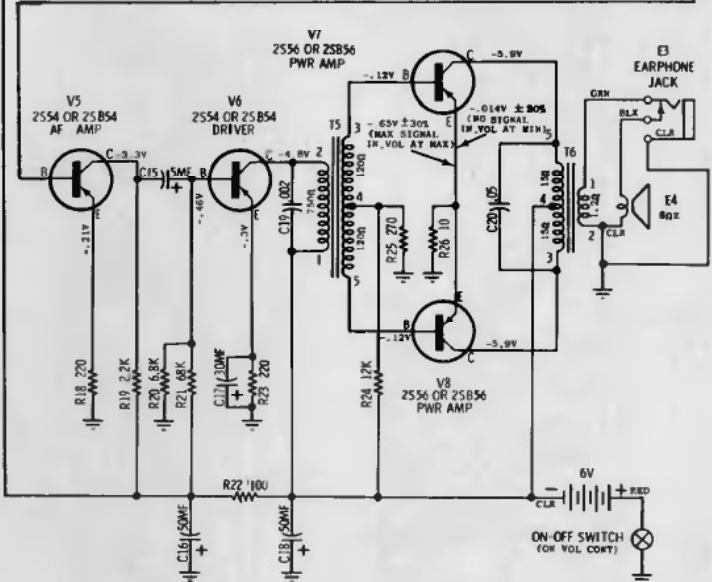

- 7 ANT CORE 600 KC
- 2 3RD IF 455 KC
- 1 4TH IF 455 KC
- 5 OSC TRIM 1620 KC
- 6 ANT TRIM 1400 KC
- 3 2ND IF 455 KC
- 6 OSC CORE 532 KC
- 4 1ST IF 455 KC

ALIGNMENT POINT LOCATIONS

CHASSIS REMOVAL

- Loosen captivated cabinet back mounting screw and pull off cabinet back.
- Remove 2 chassis mounting screws.
- Slide chassis to the right and lift out of cabinet.

SPEAKER REMOVAL

- Loosen captivated cabinet back mounting screw and pull off cabinet back.
- Remove batteries and unsolder speaker lead connected to chassis; then unsolder earphone jack lead connected to chassis.
- Remove chassis (see Chassis Removal).
- Lift up 4 speaker trim ring mounting ears (located at rear of cabinet); then remove trim ring and speaker grille.

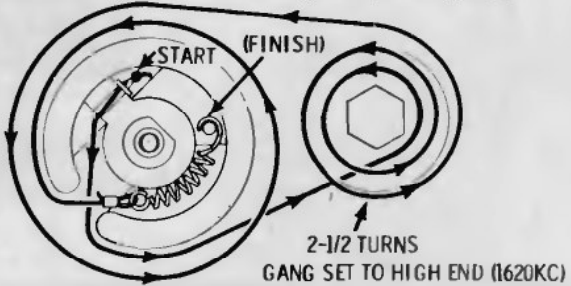

DIAL STRINGING DETAIL

MOST-OFTEN-NEEDED 1961 RADIO SERVICING INFORMATION

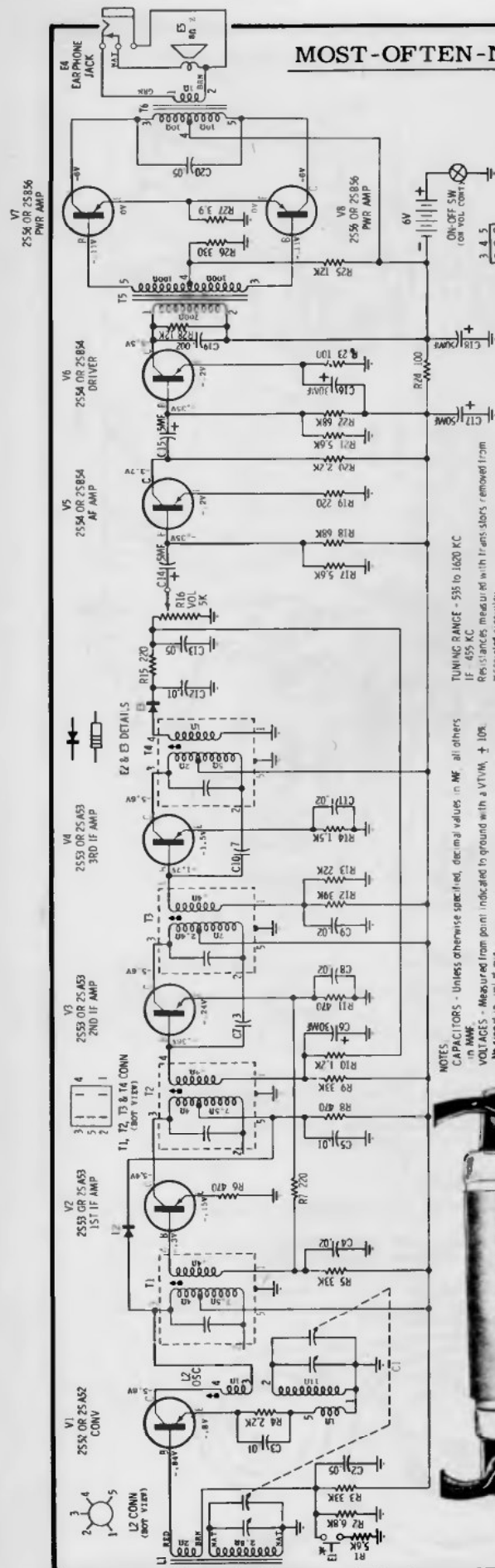

NOTES:
CAPACITORS - Unless otherwise specified, decimal values in MF all others in μ F.
RESISTORS - Measured from point indicated to ground with a VTVM, $\pm 10\%$ accuracy, in ohms if indicated.
ZERO SIGNAL CURRENT - APPROX 9 MA (MIN VOLT)

TUNING RANGE - 535 to 1620 KC
IF 455 KC
Distances measured with transistors removed from sockets if applicable.
⊥ = GROUND

CHASSIS REMOVAL

1. Lift off battery compartment cover and remove batteries.
2. Remove 2 cabinet back mounting screws located under batteries and remove cabinet back far enough to gain access to earphone jack; unscrew earphone jack mounting nut.
- NOTE: A special tool for removing the earphone jack is available. Order Motorola Part Number 66A64621.
3. Unsolder battery leads connected to battery compartment on cabinet back.
4. Unsolder lead and 5.6K resistor (R-1) connected to Battery Life Indicator Switch E-1.
5. Remove 2 chassis mounting screws.
6. Lift up chassis far enough to make bottom accessible; then unsolder appropriate leads.

SPEAKER REMOVAL

1. Remove chassis from cabinet (see Chassis Removal).
2. Remove decorative nut from cabinet front (on Battery Life Indicator Button).
3. From inside front cabinet, bend up the 8 speaker grille mounting tabs and then remove the grille and speaker gas-keet.
4. Bend up the 3 speaker mounting tabs and remove speaker (from front of cabinet).

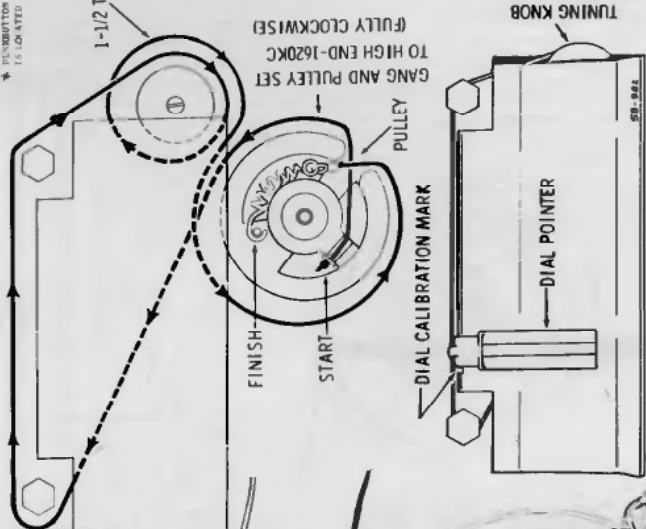

NOTE: UPON COMPLETION OF DIAL STRINGING, ROTATE TUNING KNOB FULLY COUNTERCLOCKWISE SO THAT GANG IS FULLY CLOSED (532 KC); PLACE DIAL POINTER SO THAT EDGE OF POINTER JUST COVERS DIAL CALIBRATION MARK.

DIAL STRINGING DETAIL

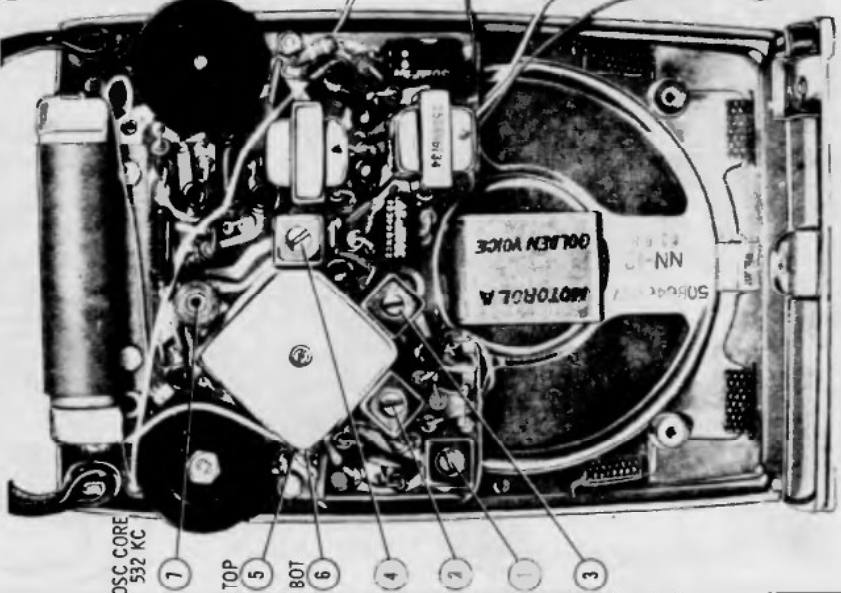

ALIGNMENT POINT LOCATIONS

MOTOROLA INC.

MODEL X19A
CHASSIS HS-799
CHASSIS HS-799

- OSC TRIM 1620 KC
- ANT TRIM 1400 KC
- 1ST IF 455 KC
- 3RD IF 455 KC
- 4TH IF 455 KC
- 2ND IF 455 KC

MOTOROLA

MODEL CHASSIS
L20E HS-800

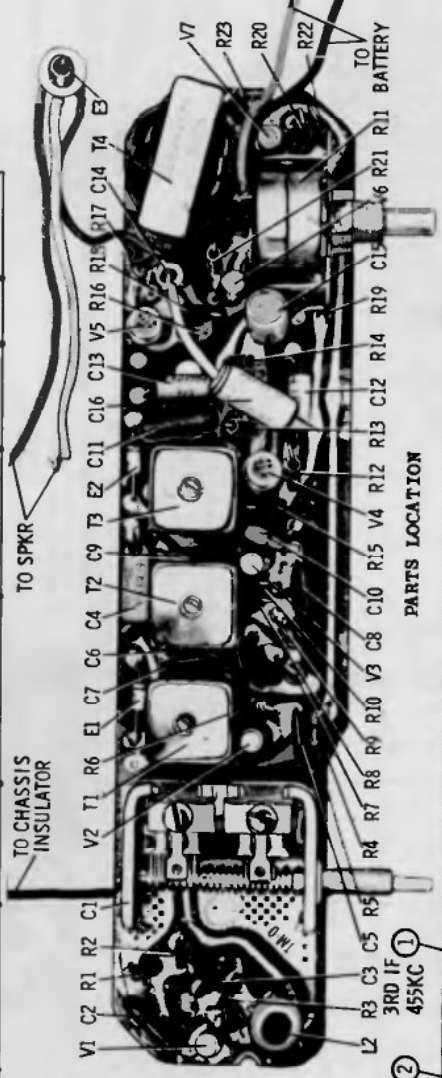
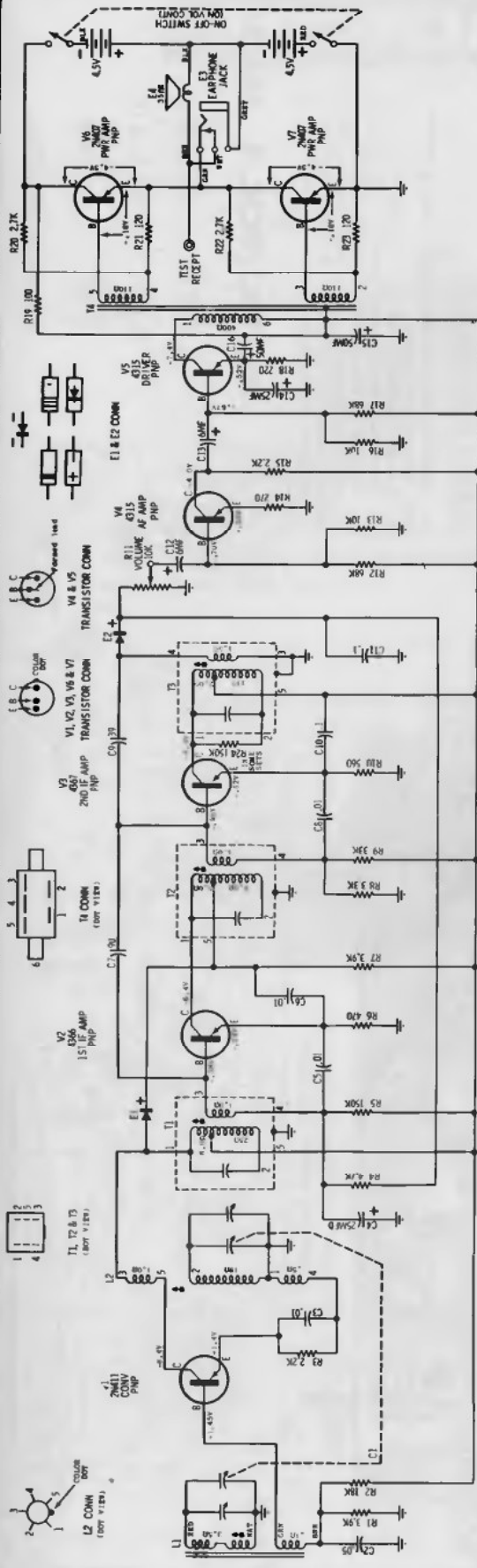

PARTS LOCATION

CHASSIS REMOVAL

1. Loosen two back panel mounting screws 5 or 6 turns (a coin can be used for a screwdriver) and remove panel (if necessary, press thumb against bottom center edge; the panel will swing free, allowing easy removal).
2. To remove cabinet back, remove 2 cabinet back mounting screws located under batteries; then remove back.
3. Remove volume, tuning and pointer knobs.
4. From front of cabinet, remove dial scale by first removing the two dial scale mounting screws, then remove scale.
5. Remove 2 chassis mounting screws located under dial scale and volume control mounting palnut.
6. Unscrew earphone jack mounting nut.
7. Unsolder chassis leads.
8. Remove chassis from cabinet.

NOTE: CAPACITORS - Unless otherwise specified, decimal values in MF, all others in MMF.
VOLTAGES - Measured from point indicated to ground or across points indicated with a VTVM, $\pm 10\%$, No signal in.
TUNING RANGE - 535 KC to 1600 KC.
IF - 455 KC.
Resistance measured with transistor's removed from associated circuitry.
ZERO SIGNAL CURRENT - APPROX. 12-14 MA (MIN VOU)

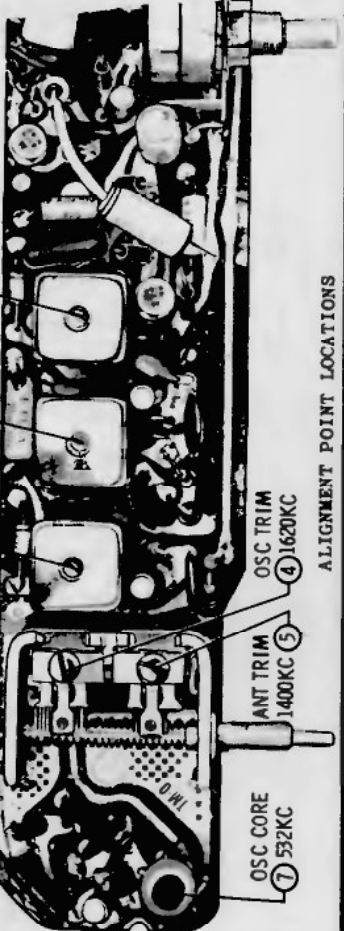

ALIGNMENT POINT LOCATIONS

VOLUME MOST-OFTEN-NEEDED 1961 RADIO SERVICING INFORMATION

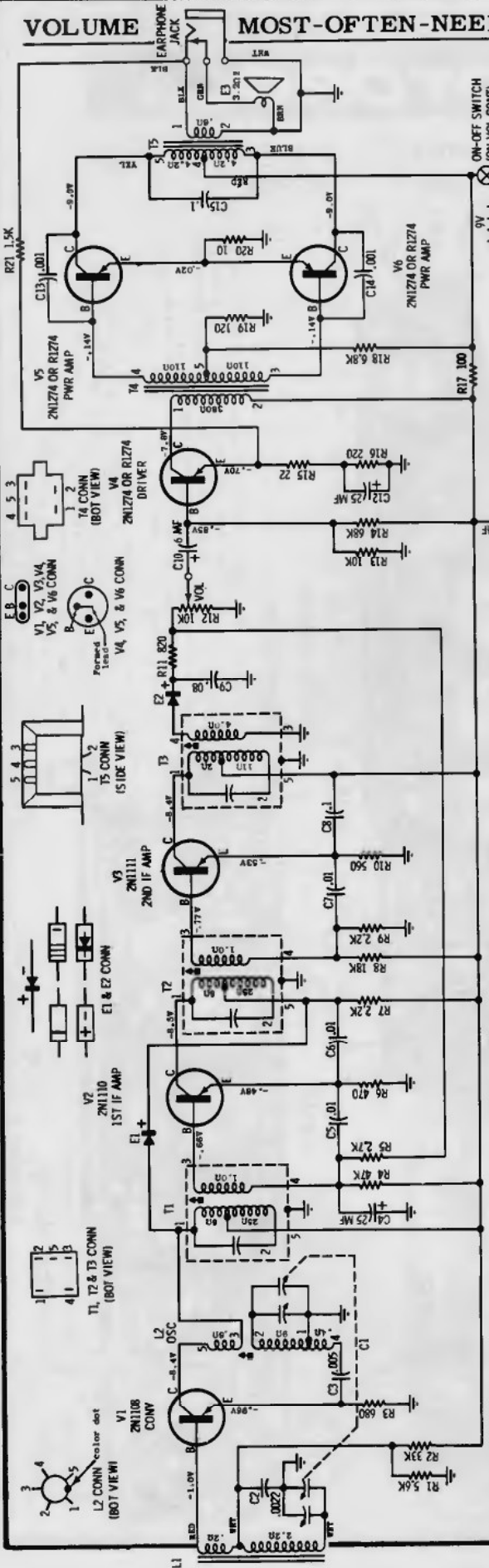

OSC CORE	ANT TRIM	OSC TRIM	1ST IF	2ND IF	3RD IF
532 KC	1400 KC	1620 KC	455 KC	455 KC	455 KC
⑥	⑤	④	③	②	①

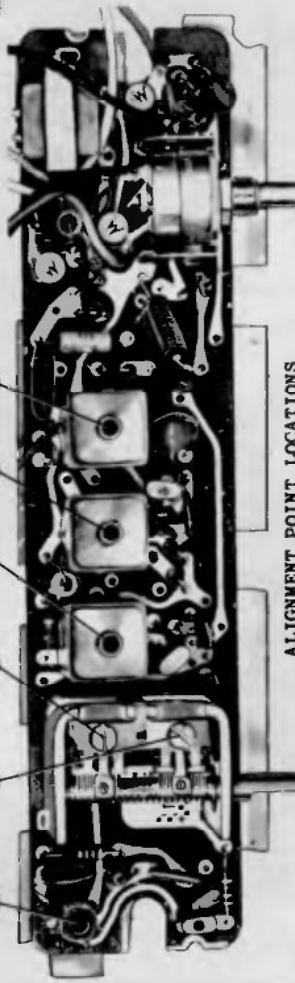

ALIGNMENT POINT LOCATIONS

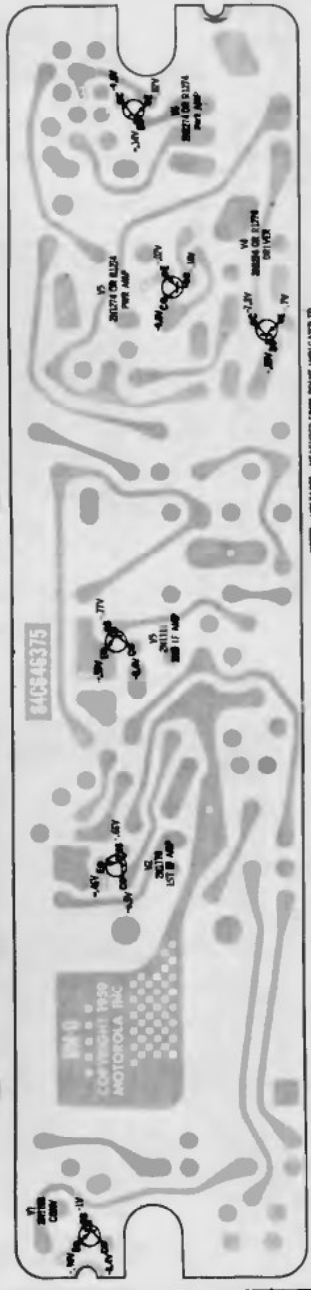

VOLTAGE READINGS TAKEN FROM BOTTOM SIDE OF CHASSIS

NOTES: CAPACITORS - Unless otherwise specified, decimal values in μ F, all others in MMF.
 VOLTAGES - Measured from point indicated to ground with a VTVM, $\pm 10\%$. No signal in.
 TUNING RANGE - 535 KC to 1620 KC.
 IF - 455 KC.

Resistance measured with transistors removed from associated circuitry.
 ZERO SIGNAL CURRENT - APPROX 12MA. A. 0MIN VOLU

CABINET BACK REMOVAL

1. Loosen captivated back panel mounting screws completely and remove back panel.
2. Remove batteries and unsnap connectors.
3. Press button to release handle.
4. Remove 2 cabinet back mounting screws.
5. Unfasten actuator arms from handle rods by using a screwdriver (to push them to the side).
6. Remove cabinet back.

MOTOROLA INC.

PORTABLE / TABLE RADIO
 MODEL XT188
 CHASSIS HS-802
 HS-802
 CORDLESS 1500 SERIES

NOTES - VOLTAGES - MEASURED FROM POINT LABEL CAVED TO CHASSIS (E.G. WITH A VTVM, $\pm 10\%$, NO SIGNAL IN.)

MOTOROLA

MODELS	CHASSIS
C10N	HS-813
C10P	HS-813
C10W	HS-813

The material on this page is exact for sets listed above. The additional radios listed below are practically identical electrically.

MODELS	CHASSIS
C11B	HS-814
C11G	HS-814
C11S	HS-814

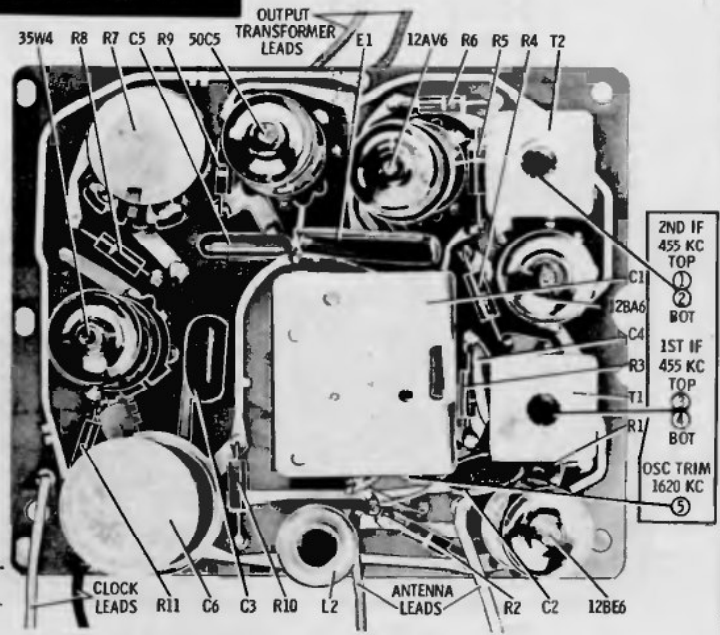

ALIGNMENT POINTS AND PARTS LOCATION

TO REMOVE CHASSIS FROM CABINET

1. Remove volume and tuning knobs.
2. Remove cabinet back - 2 screws hold it in place.
3. From front, remove palnut located under volume knob.
4. From rear, unsolder 2 cabinet back loop leads, then remove 3 chassis mounting screws.
5. Remove chassis from cabinet; to free chassis, unsolder appropriate leads.

ALIGNMENT

Use an isolation transformer between the power line and the receiver. If not available, connect low side of generator to B- through a .1 mf capacitor. Connect a low range output meter across speaker voice coil and set volume control to maximum. Attenuate generator output to maintain .64 volts on output meter to prevent overloading.

STEP	GENERATOR CONNECTION	GENERATOR FREQUENCY (400 cycle mod)	GANG SETTING	ADJUST	REMARKS
IF ALIGNMENT					
1.	Grid of conv (pin 7, 12BE6) thru .1 mf & B-	455 Kc	Fully open	1,2,3, & 4	Adjust for maximum.
RF ALIGNMENT					
2.	Grid of conv (pin 7, 12BE6) thru .1 mf & B-	1620 Kc	Fully open	5	Adjust for maximum.

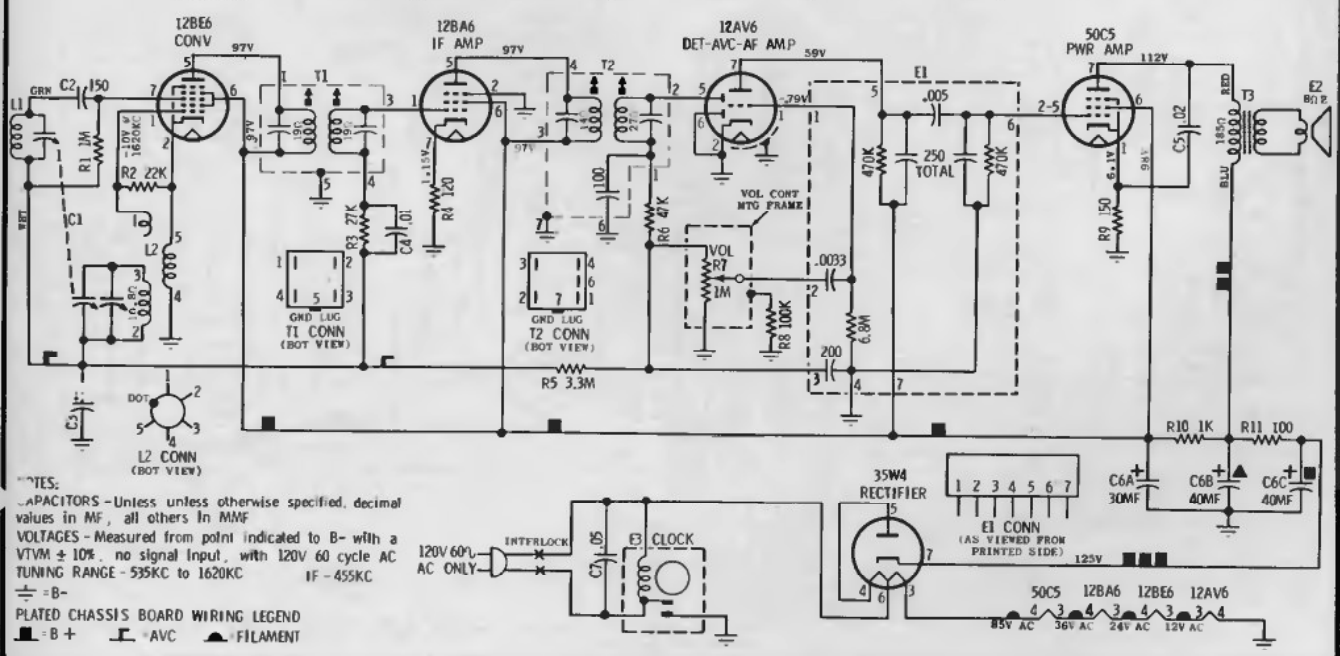

MOTOROLA INC.

MODELS	CHASSIS
C12B	HS-815
C12P	HS-815
C12W	HS-815

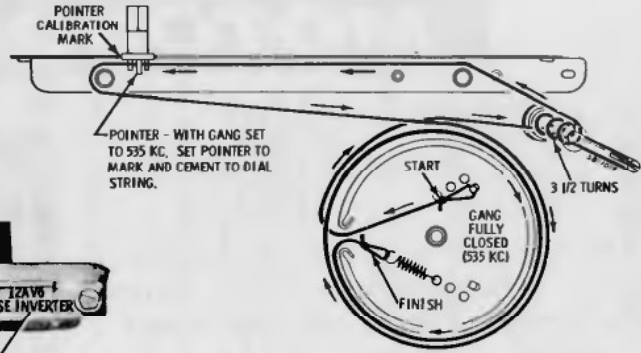

DIAL STRINGING DETAIL

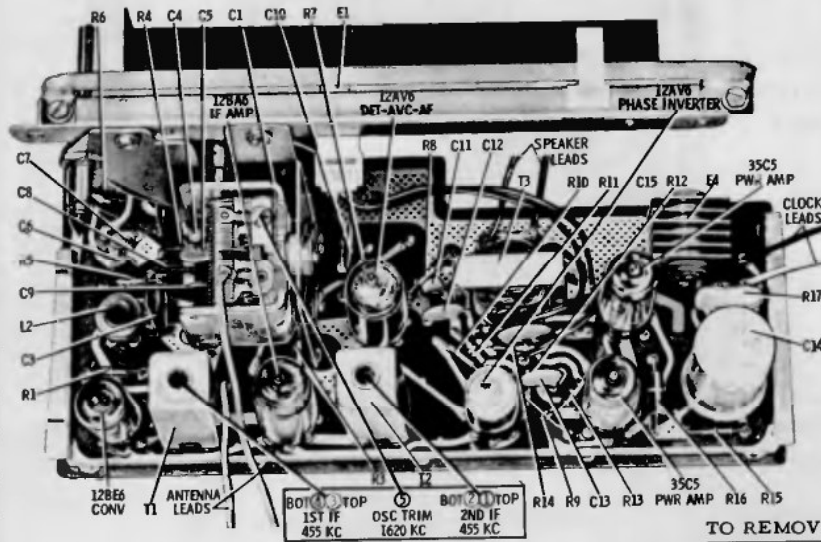

ALIGNMENT POINTS AND PARTS LOCATION

TO REMOVE CLOCK FROM CABINET

1. Remove cabinet back - 5 screws hold it in place.
2. Unsolder all leads connected to clock.
3. Remove 2 appliance outlet bracket mounting screws and remove bracket.
4. Insert a screwdriver between the cabinet and left edge of the clock crystal (near 9 o'clock on clock face) to release catch, then pry out crystal.
5. Set the Hour, Minute and Alarm Set hands to 12 o'clock (use the Time Set-Auto Set knob for this purpose). Remove clock hands by pulling them straight off from their mounting shaft in this order: Second, Minute, Hour and Alarm Set.
6. From rear, remove 4 clock mounting lock screws and remove clock from cabinet.

TO REMOVE CHASSIS FROM CABINET

1. Remove cabinet back - 5 screws hold it in place.
2. From rear, unsolder 2 cabinet back loop leads, then remove the 2 screws that mount the pointer slide bracket (on chassis) to the cabinet.
3. Unsolder 2 chassis leads connected to clock and 2 speaker leads.
4. Remove volume and tuning knobs.
5. From front, remove palnut located under volume knob.
6. Remove chassis from cabinet.

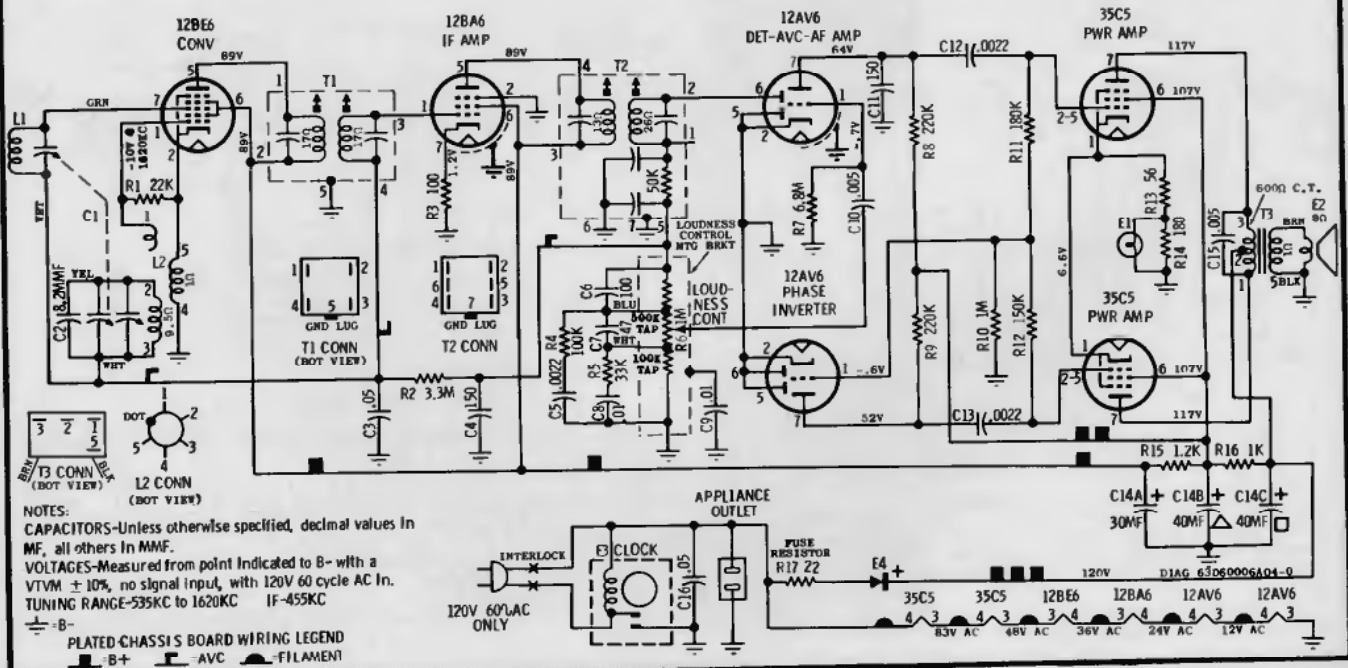

VOLUME R-21, MOST-OFTEN-NEEDED 1961 RADIO SERVICING INFORMATION

NOTES:
 CAPACITORS—unless otherwise specified, decimal values in MF, all others in MMF.
 VOLTAGES—Measured from point indicated to B— with a VTVM $\pm 10\%$, no signal input, with 120V 60 cycle AC in.
 TUNING RANGE—535KC to 1620KC (1F-455KC)
 PLATED CHASSIS BOARD WIRING LEGEND
 B+ — AVC — FILAMENT

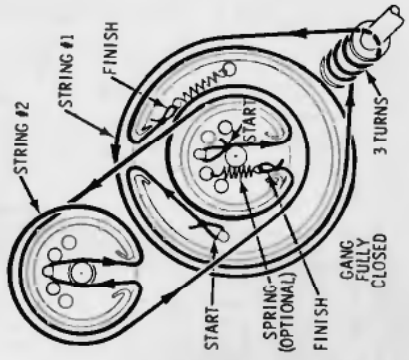

DIAL STRINGING DETAIL

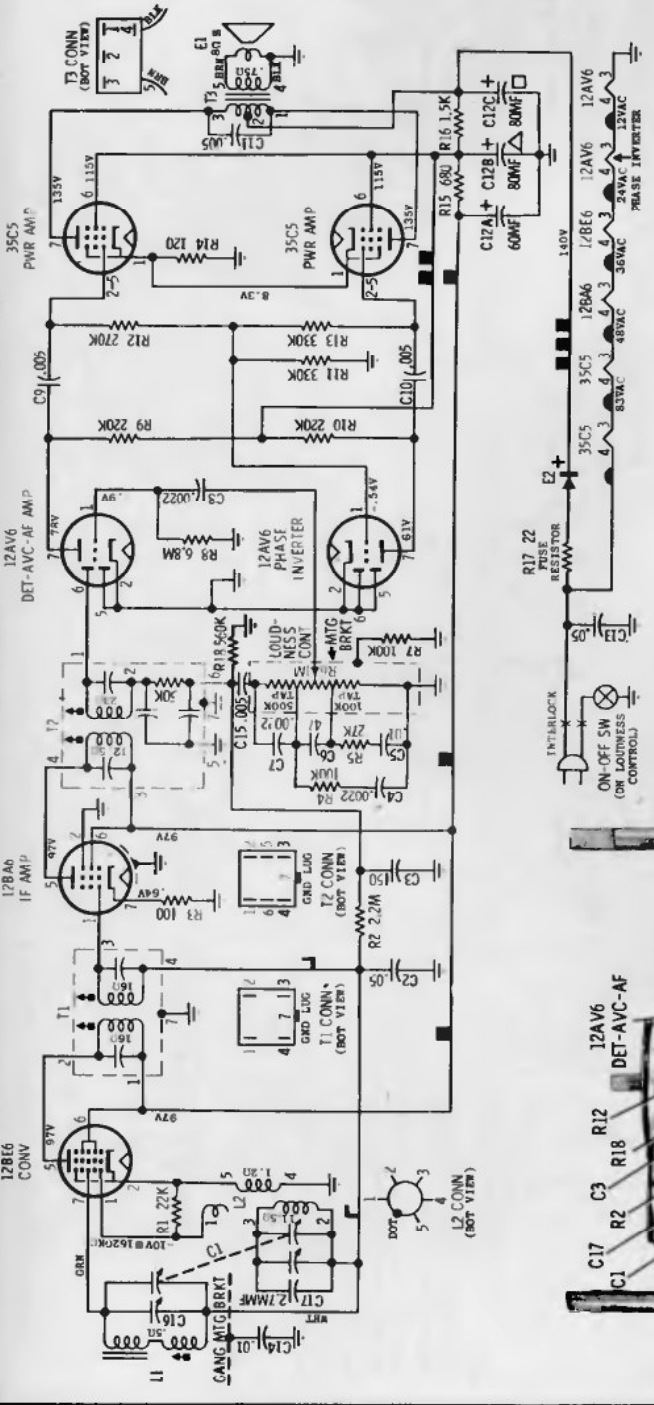

Ref. No.	Part Number	Description
C-1	19B60323A01	Capacitor, variable; 2 gang
C-2	8B128613	Capacitor, mylar; .05 mf 500V
C-3	21K129730	Capacitor, cer disc; 150 mf 500V
C-4	21K129965	Capacitor, cer disc; .01 mf 500V
C-5	21K129718	Capacitor, cer disc; .01 mf 500V
C-6	21R115493	Capacitor, cer disc; 47 mf 500V
C-7	21K129965	Capacitor, cer disc; .0022 mf 500V
C-8	21K129965	Capacitor, cer disc; .0022 mf 500V
C-9	21K129921	Capacitor, cer disc; .005 mf 500V
C-10	21K129921	Capacitor, cer disc; .005 mf 500V
C-11	21K129921	Capacitor, cer disc; .005 mf 500V
C-12	23B60423A01	Capacitor, electrolytic; 60-80 mf/150V
C-13	8B128613	Capacitor, mylar; .05 mf 400V
C-14	21K129718	Capacitor, cer disc; .01 mf 500V
C-15	21K129921	Capacitor, cer disc; .005 mf 500V
C-16	20B60120A01	Capacitor, mica trim; 1.3 mf to 11 mf
C-17	21A541621	Capacitor, cer tub; 2.7 mf 500V NTC

TO REMOVE CHASSIS FROM CABINET

1. Remove back cover - 4 screws hold it in place.
2. From rear, remove 3 dial crystal mounting screws and 3 chassis mounting screws.
3. From front, remove 2 control knobs, dial crystal and dial pointer (observe dial calibration).
4. Unsolder 2 speaker leads and remove chassis from cabinet.

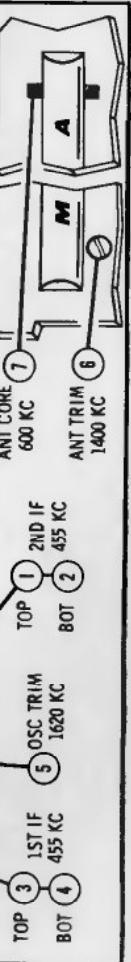
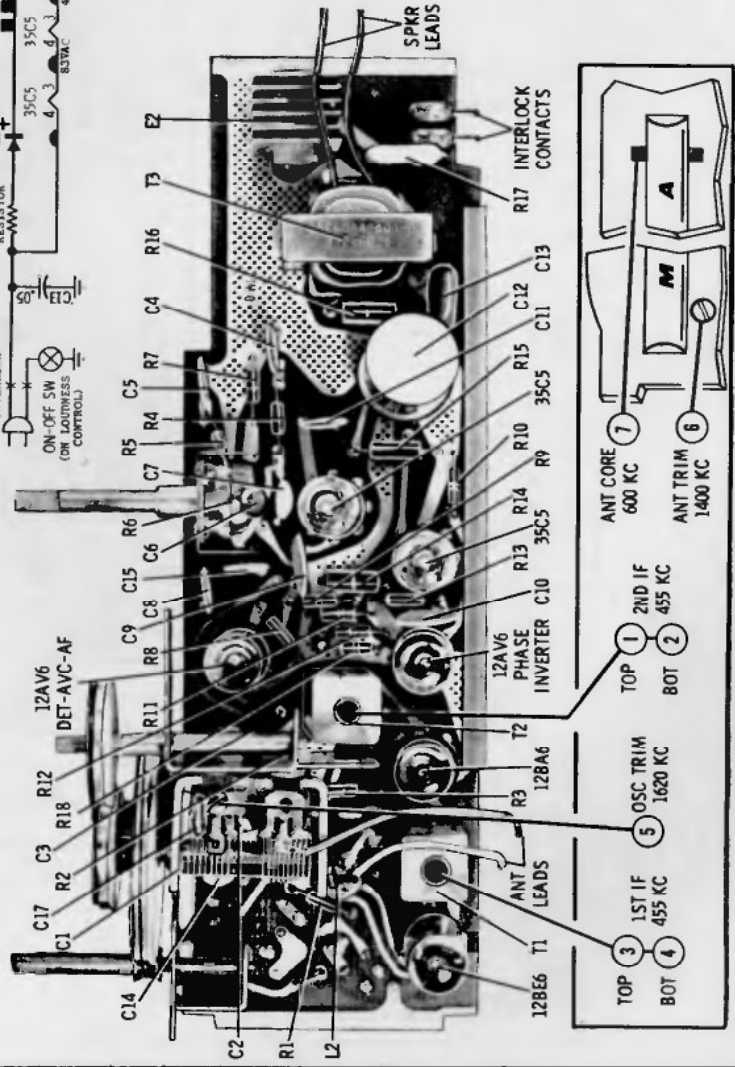

ALIGNMENT ADJUSTMENTS & PARTS LOCATION

MOTOROLA
 MODELS CHASSIS
 A11A HS-824
 A11W HS-824

OFTEN-NEEDED 1961 RADIO SERVICING INFORMATION

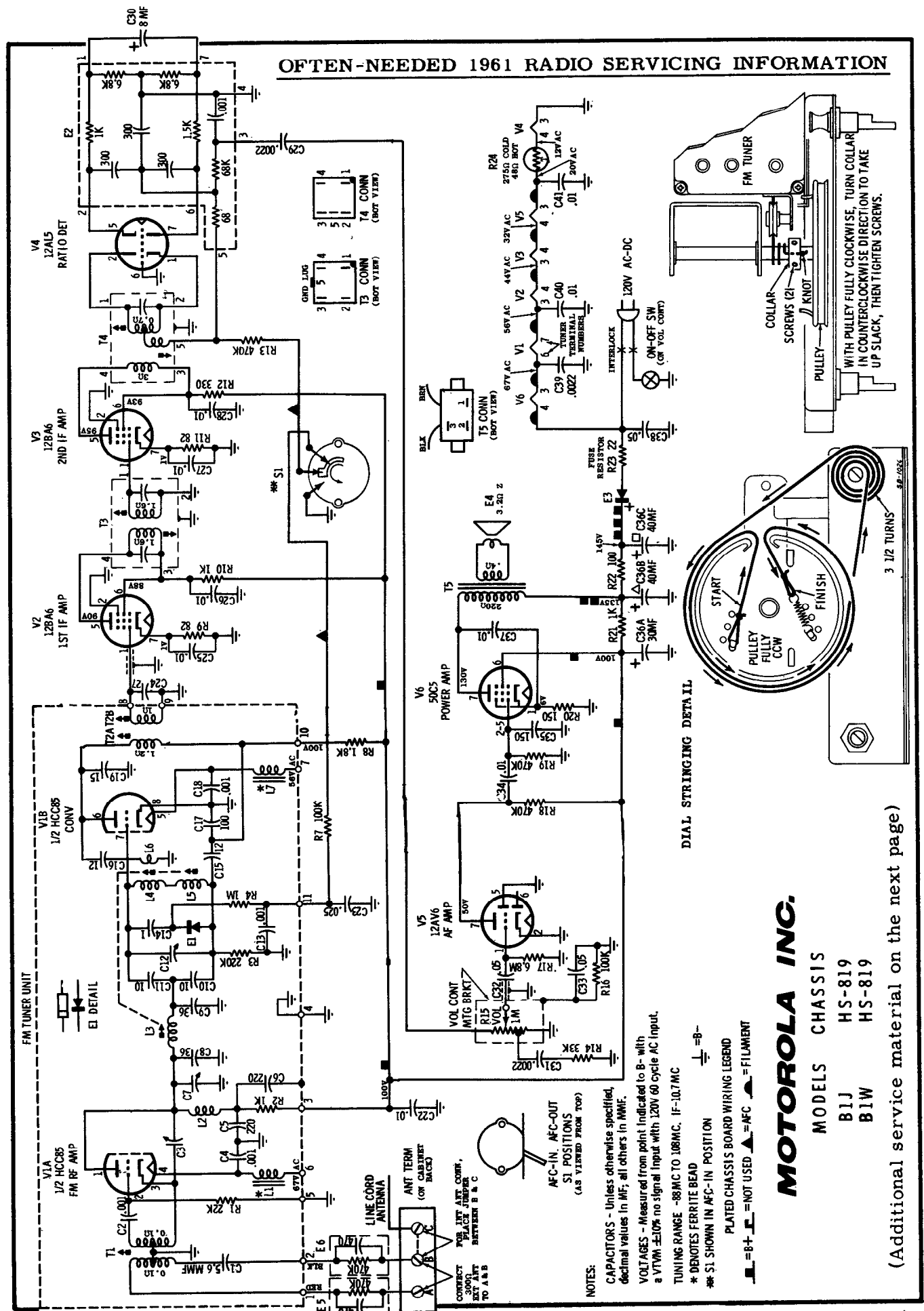

MOTOROLA INC.

MODELS CHASSIS
 BIJ HS-819
 BIW HS-819

(Additional service material on the next page)

MOTOROLA INC.

MODELS CHASSIS

B1J HS-819

B1W HS-819

(Continued from preceding page)

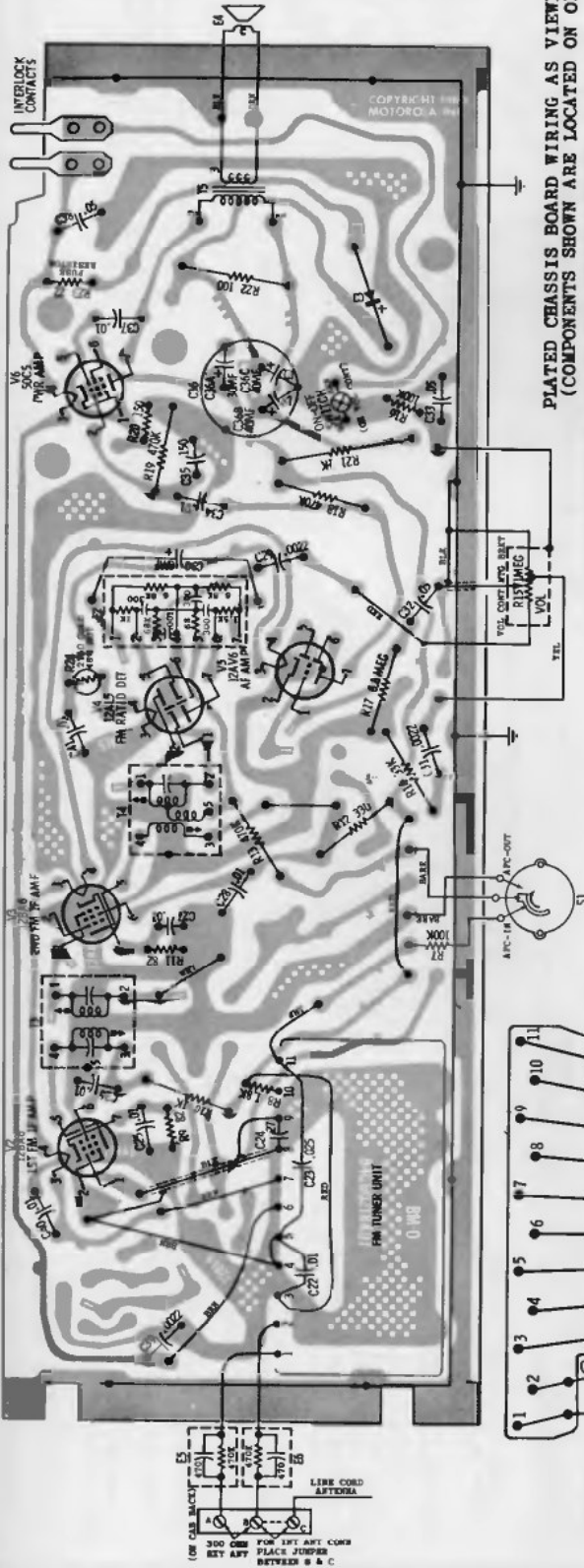

PLATED CHASSIS BOARD WIRING AS VIEWED FROM BOTTOM
(COMPONENTS SHOWN ARE LOCATED ON OPPOSITE SIDE)

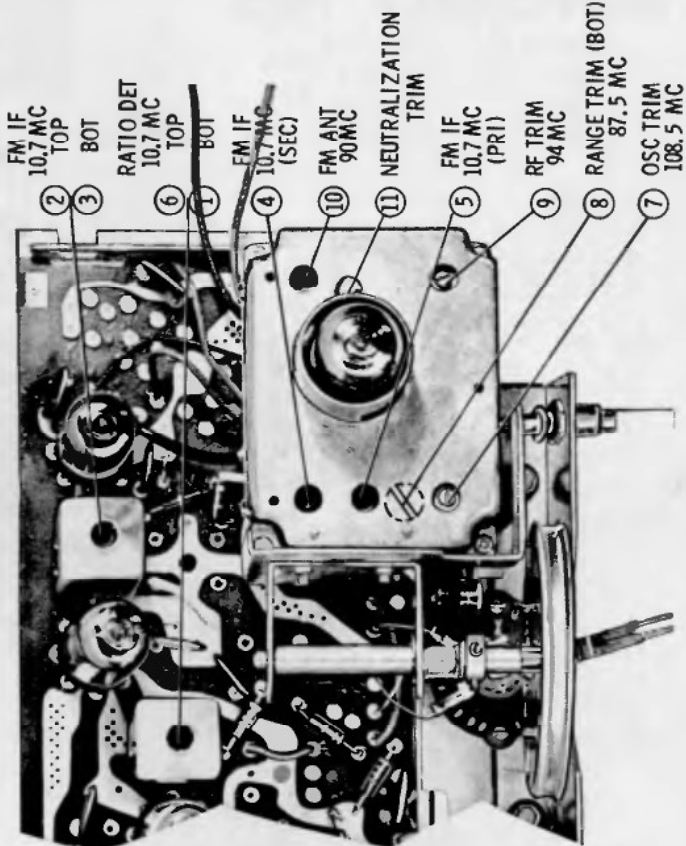

ALIGNMENT POINTS LOCATION

NOTES:
CAPACITORS - Unless otherwise specified, decimal values in MF, all others in MMF.
ON SCHEMATIC
PLATED CHASSIS BOARD WIRING LEGEND
-B + - NOT USED - AFC - FILAMENT

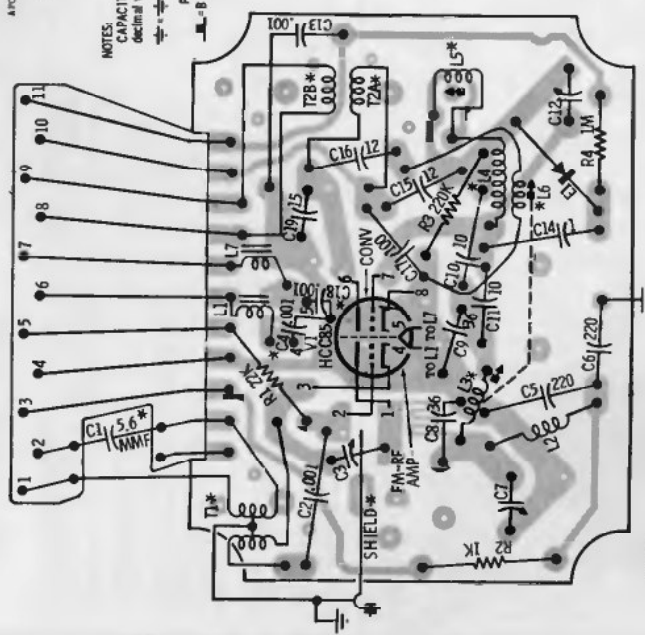

NOTES:
CAPACITORS - Unless otherwise specified decimal values in MF, all others in MMF.
ON SCHEMATIC
*LOCATED ON CONDUCTION SIDE OF BOARD
FM TUNER PLATED CHASSIS WIRING
(The view shown is from the conduction side of the board; the components shown are actually located on the opposite side).

MOTOROLA INC.

MODELS	CHASSIS
B2G	HS-820
B2N	HS-820
B2W	HS-820

(Continued on the next page)

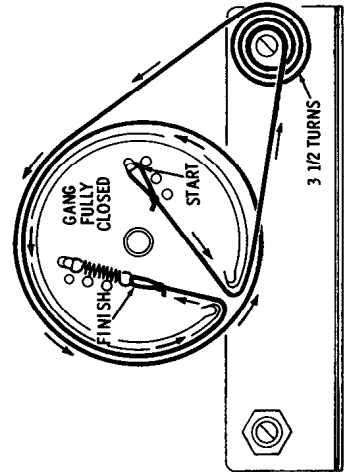
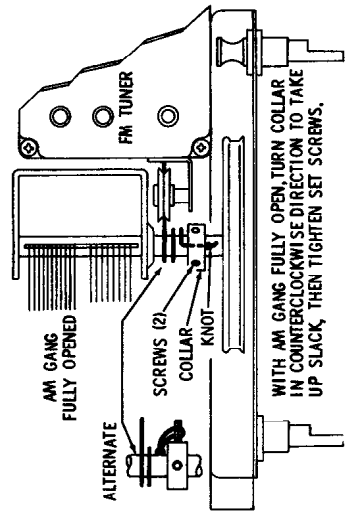
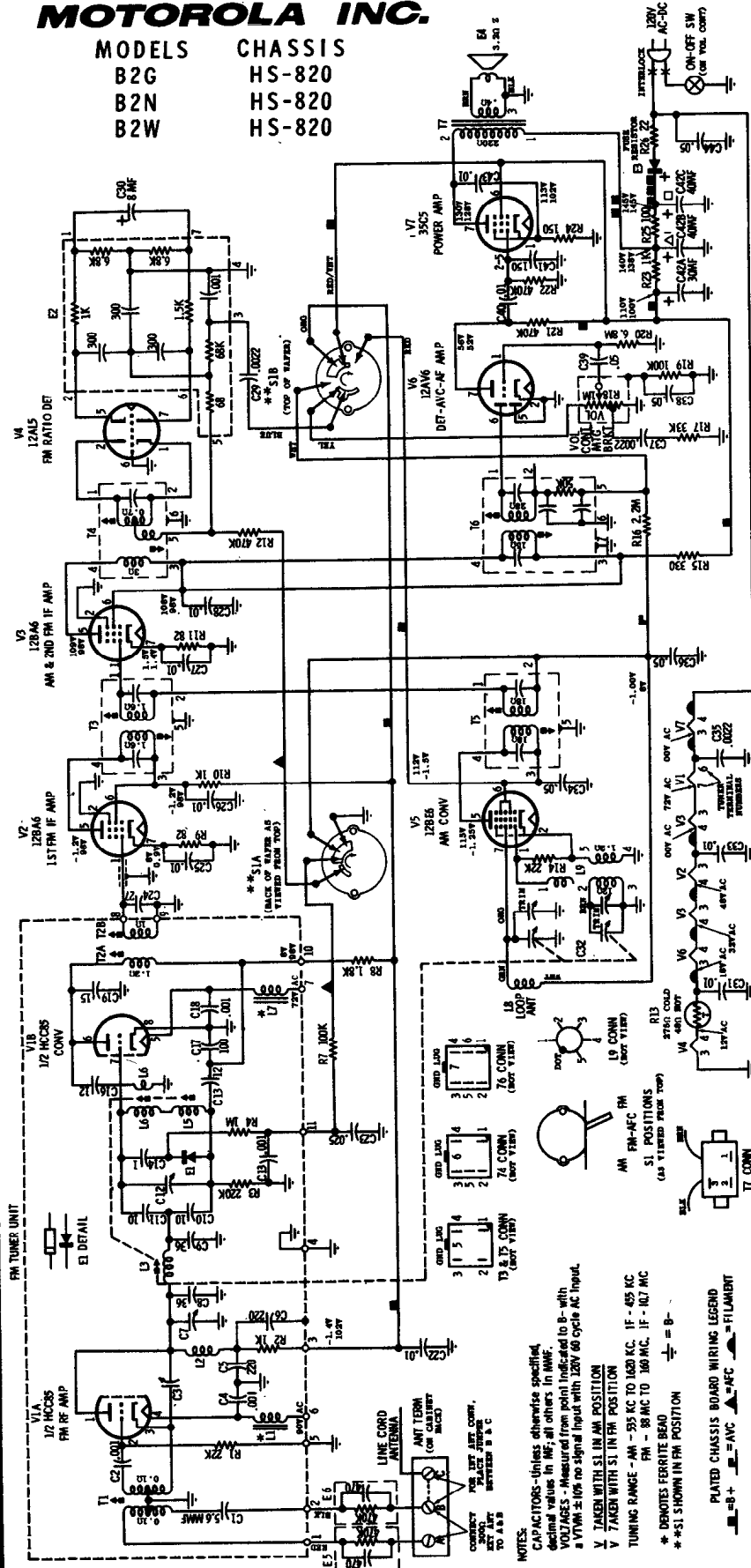

(Continued on the next page)

TO REMOVE CHASSIS FROM CABINET

1. Remove control knobs - pull straight off.
2. Remove 4 screws holding cabinet back to cabinet.
3. Remove 2 screws holding chassis support channel.
4. Remove 1 screw holding drive pulley bracket to inside front of cabinet.
5. Unsolder speaker leads.
6. Remove chassis from cabinet.

MOTOROLA

(Service material continued from preceding page)

MODELS	CHASSIS
B2G	HS-820
B2N	HS-820
B2W	HS-820

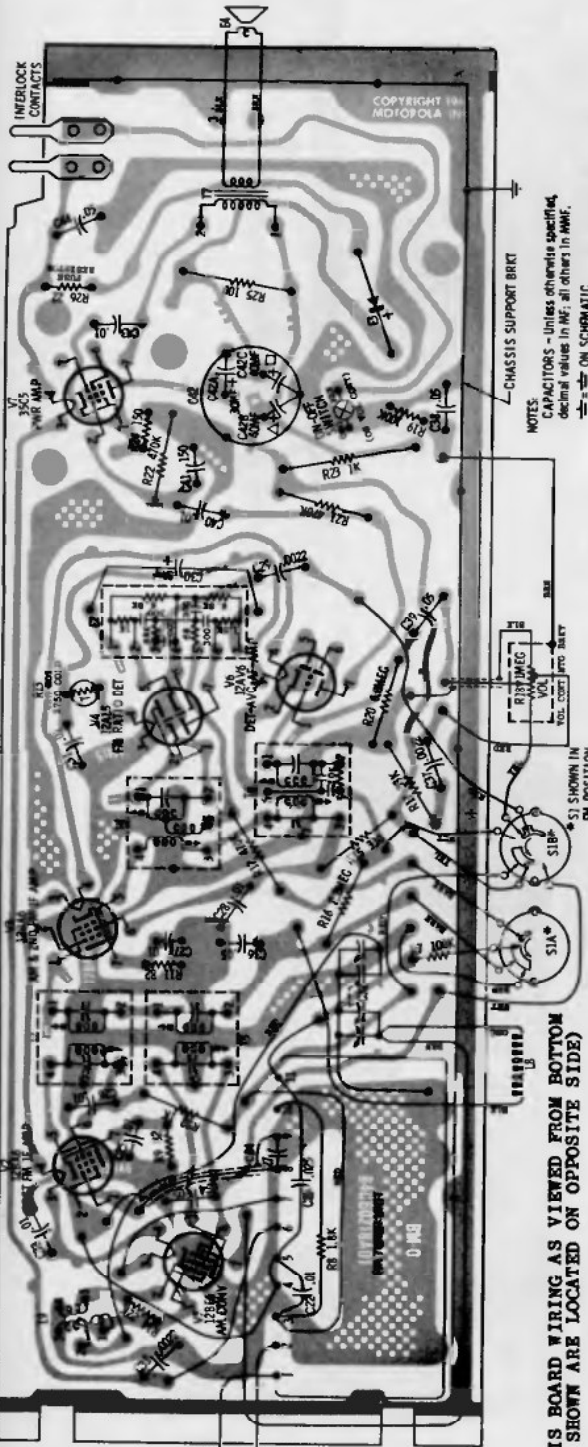

PLATED CHASSIS BOARD WIRING AS VIEWED FROM BOTTOM (COMPONENTS SHOWN ARE LOCATED ON OPPOSITE SIDE)

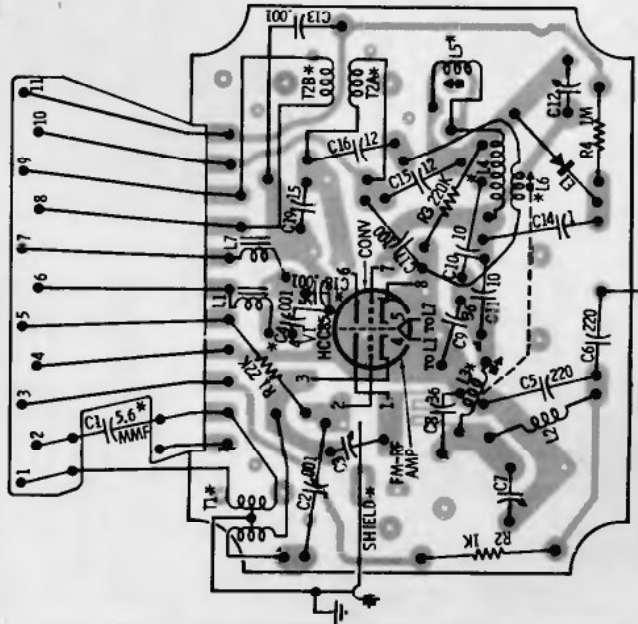

FM TUNER PLATED CHASSIS WIRING

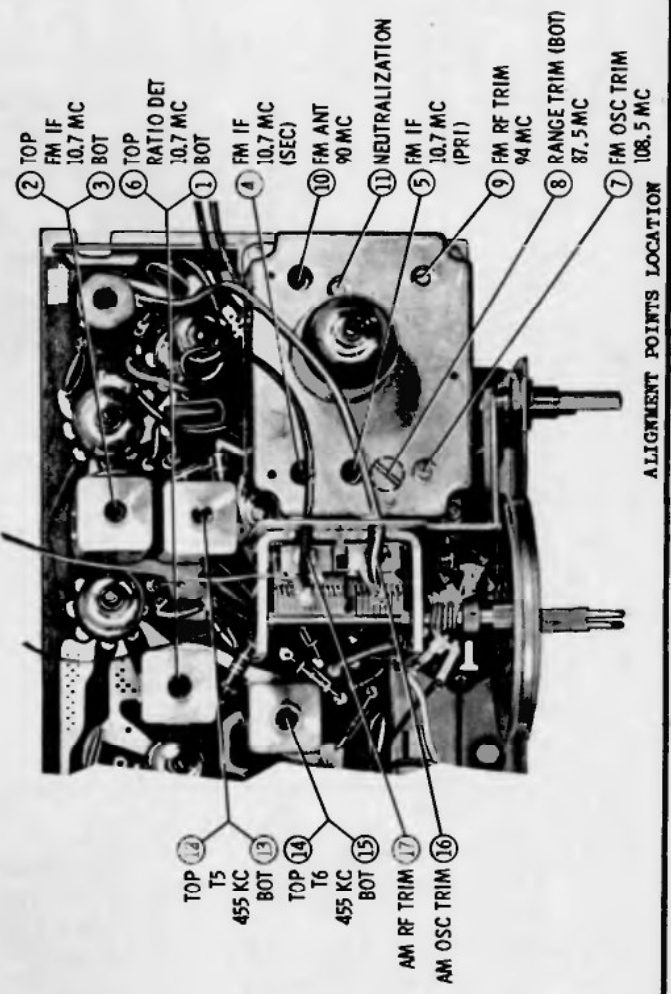

ALIGNMENT POINTS LOCATION

NOTES:
CAPACITORS - unless otherwise specified, decimal values in MF, all others in MMF.
ON SCHEMATIC
PLATED CHASSIS BOARD WIRING LEGEND
-B + -AVC -AFC -FILAMENT

- 1 TOP FM IF 10.7 MC
- 2 BOT
- 3 TOP RATIO DET 10.7 MC
- 4 BOT
- 5 FM IF 10.7 MC (ISEC)
- 6 FM ANT 90 MC
- 7 NEUTRALIZATION
- 8 FM IF 10.7 MC (PRI)
- 9 FM RE TRIM 94 MC
- 10 RANGE TRIM (BOT) 87.5 MC
- 11 FM OSC TRIM 108.5 MC
- 12 TOP T5 455 KC
- 13 BOT
- 14 TOP T6 455 KC
- 15 BOT
- 16 AM OSC TRIM
- 17 AM RE TRIM
- 18 TOP

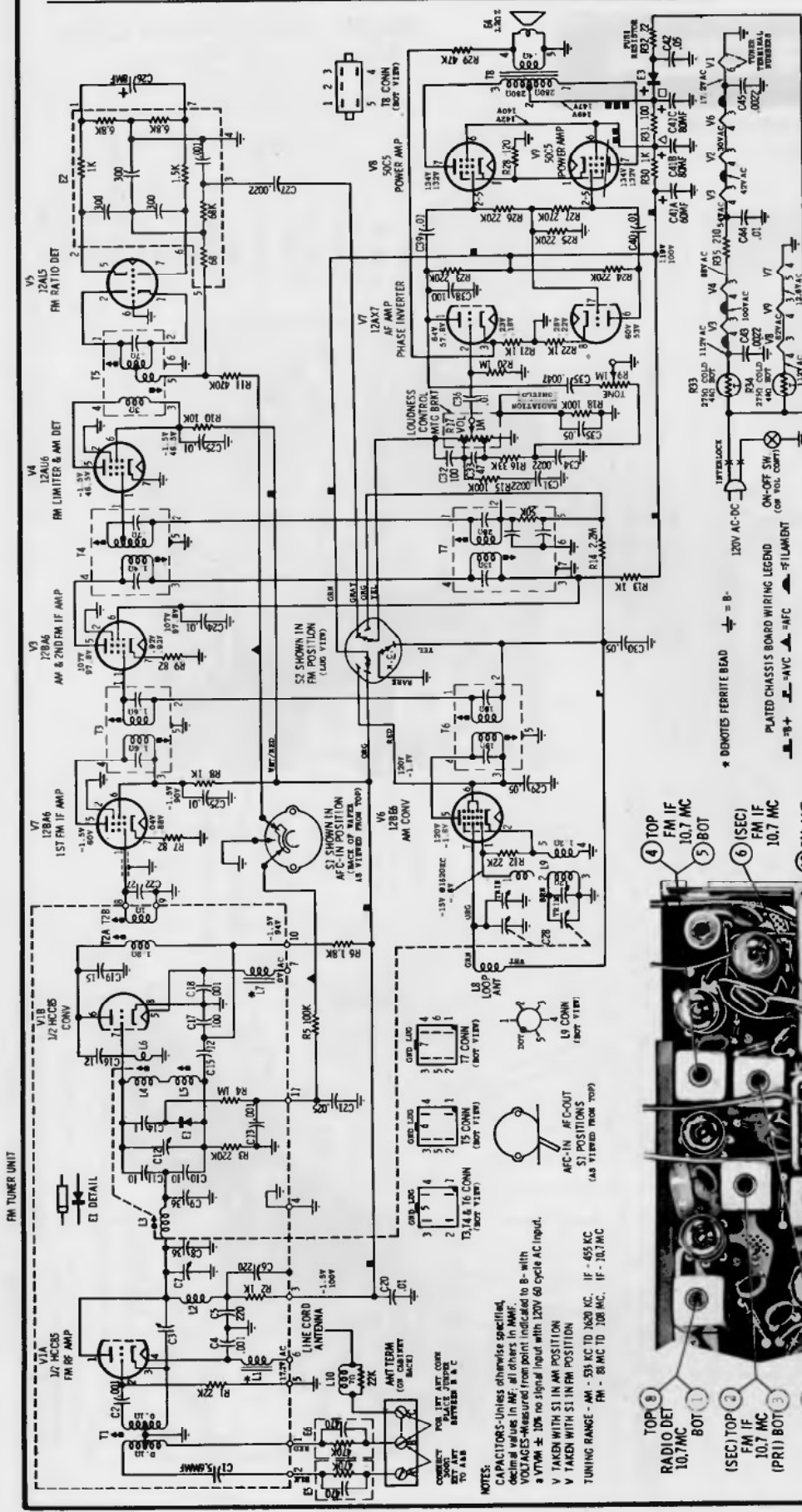

MOTOROLA

MODEL CHASSIS
B3E HS-821
B3W HS-821

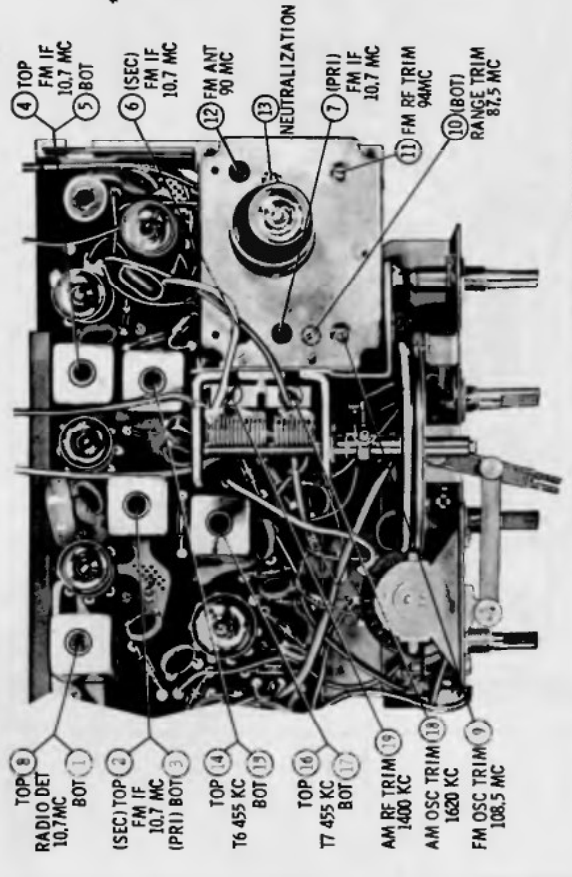

(Continued on the next page, adjacent at right)

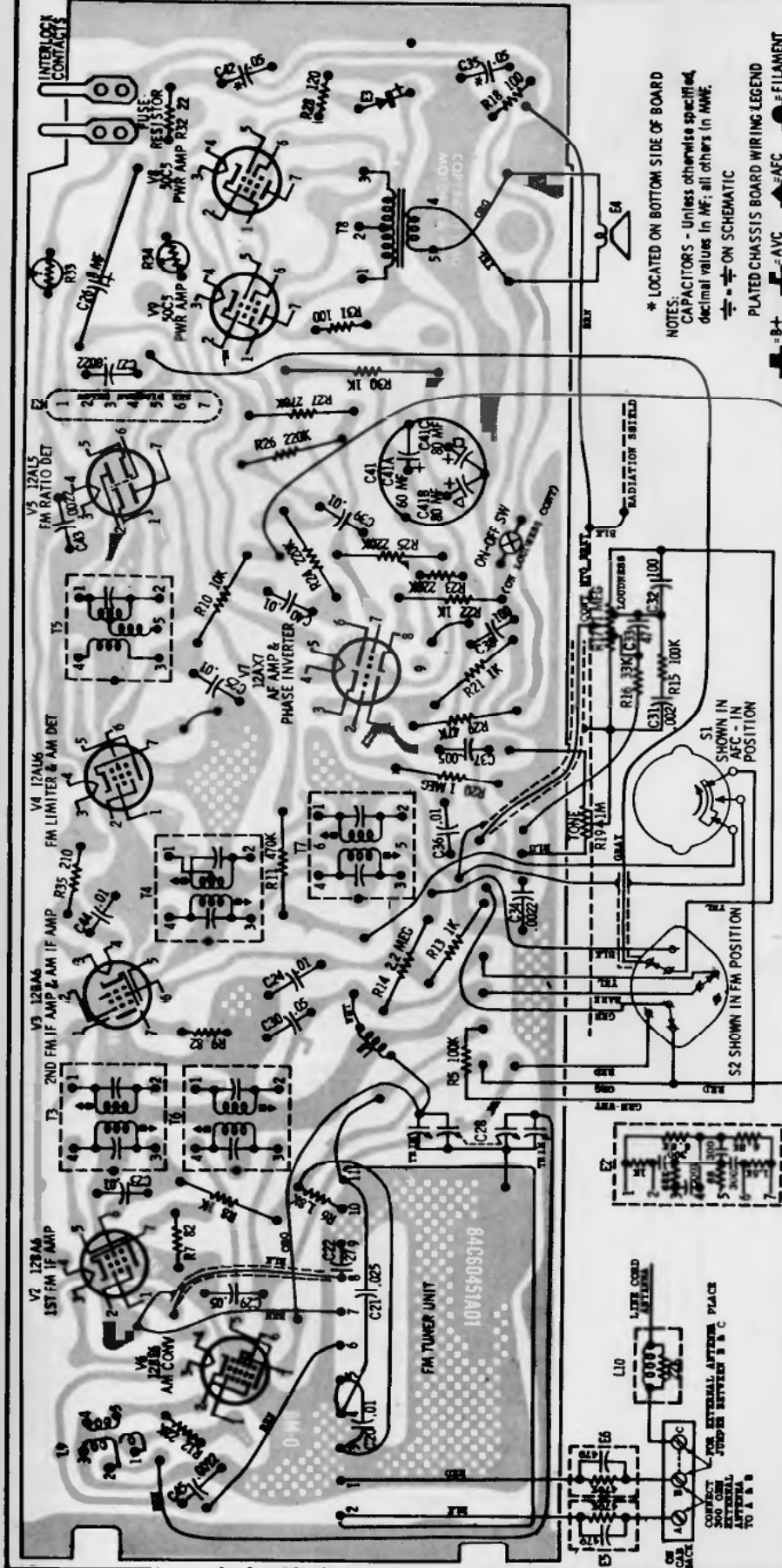

PLATED CHASSIS BOARD WIRING AS VIEWED FROM BOTTOM (COMPONENTS SHOWN ARE LOCATED ON OPPOSITE SIDE)

TO REMOVE CHASSIS FROM CABINET

1. Remove control knobs - pull straight off.
2. Remove 4 screws holding cabinet back to cabinet.
3. Remove 2 screws holding chassis support channel.
4. Remove 1 screw that mounts the AM gang mounting bracket to cabinet.
5. Remove dial crystal from cabinet - insert a screwdriver between the cabinet and top edge of the crystal to release catch, then pry out crystal.
6. Remove dial pointer - pull straight out.
7. Remove 2 chassis mounting palmuts from front of radio.
8. Unsolder speaker leads. 9. Unsolder lead of bottom shield.
10. Remove chassis from cabinet.

MOTOROLA Model B3E, W, Chassis HS-821
(Material continued from preceding page)

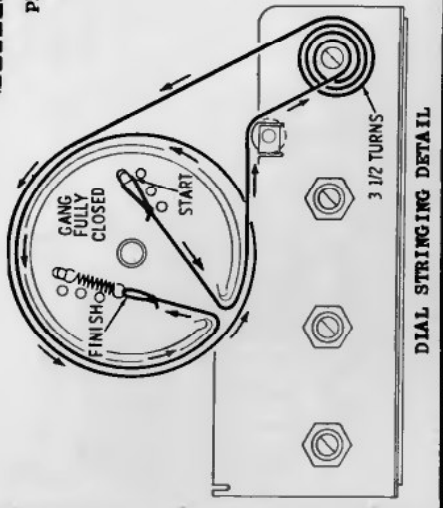

PLATED CHASSIS BOARD WIRING AS VIEWED FROM BOTTOM (COMPONENTS SHOWN ARE LOCATED ON OPPOSITE SIDE)

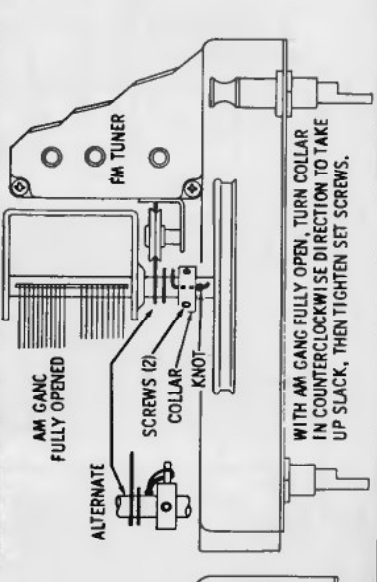

DIAL STRINGING DETAIL

* LOCATED ON BOTTOM SIDE OF BOARD
NOTES:
CAPACITORS - Unless otherwise specified, decimal values in MF; all others in MMF.
= ON SCHEMATIC
PLATED CHASSIS BOARD WIRING LEGEND
= B+ = AVC = AFC = FILAMENT

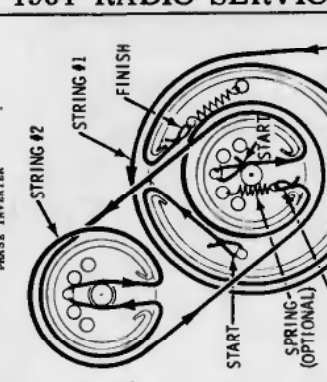
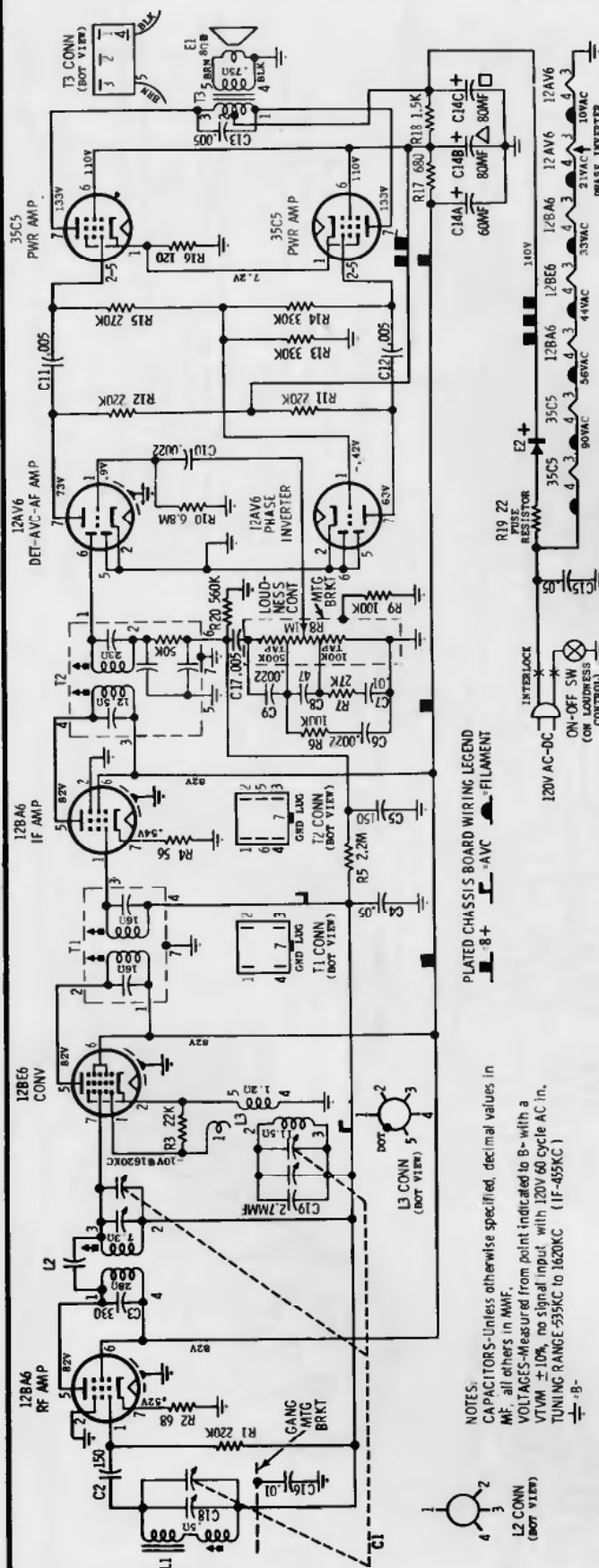

MOTOROLA

MODEL A12N CHASSIS HS-825

- TO REMOVE CHASSIS FROM CABINET**
1. Remove back cover - 4 screws hold it in place.
 2. From rear, remove 3 dial crystal mounting screws and 3 chassis mounting screws.
 3. From front, remove 2 control knobs, dial crystal and dial pointer (observe dial calibration).
 4. Unsolder 2 speaker leads and remove chassis from cabinet.

MOTOROLA

STEREO

MODEL CHASSIS
SH20 HS-827 AUDIO AMP
HS-828 PWR SUPPLY

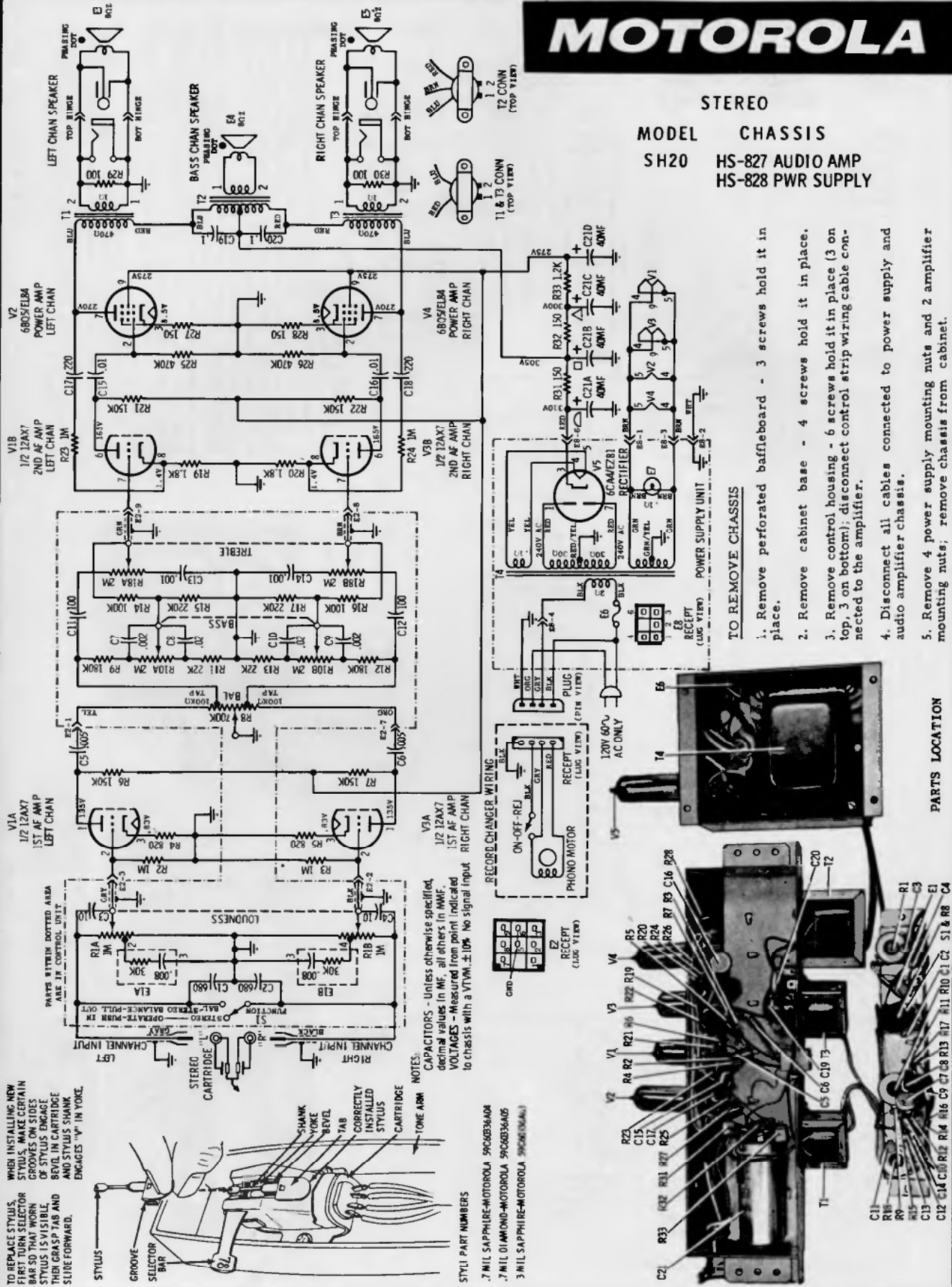

TO REPLACE STYLUS, FIRST TURN SELECTOR BAR SO THAT WORN STYLUS IS VISIBLE, THEN GRASP TAB AND SLIDE FORWARD.

WHEN INSTALLING NEW STYLUS, MAKE CERTAIN GROOVES ON SIDES OF STYLUS IS VISIBLE, BEVEL IN CARTRIDGE AND STYLUS SHANK ENAGES "V" IN YOKE.

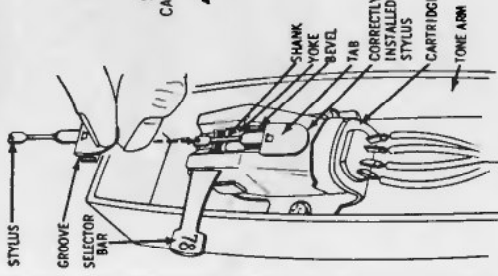

- STYLUS PART NUMBERS
- .7 MIL SAPPHIRE-MOTOROLA 59C6B36A08
 - .7 MIL DIAMOND-MOTOROLA 59C6B36A08
 - 3 MIL SAPPHIRE-MOTOROLA 59C6B36A08

NOTES:
CAPACITORS - Unless otherwise specified, decimal values in MF, all others in MME.
VOLTAGES - Measured from point indicated to chassis with a VTVM, ±10%. No signal input.

PARTS WITHIN DOTTED AREA ARE IN CONTROL UNIT

TO REMOVE CHASSIS

1. Remove perforated baffleboard - 3 screws hold it in place.
2. Remove cabinet base - 4 screws hold it in place.
3. Remove control housing - 6 screws hold it in place (3 on top, 3 on bottom); disconnect control strip wiring cable connected to the amplifier.
4. Disconnect all cables connected to power supply and audio amplifier chassis.
5. Remove 4 power supply mounting nuts and 2 amplifier mounting nuts; remove chassis from cabinet.

PARTS LOCATION

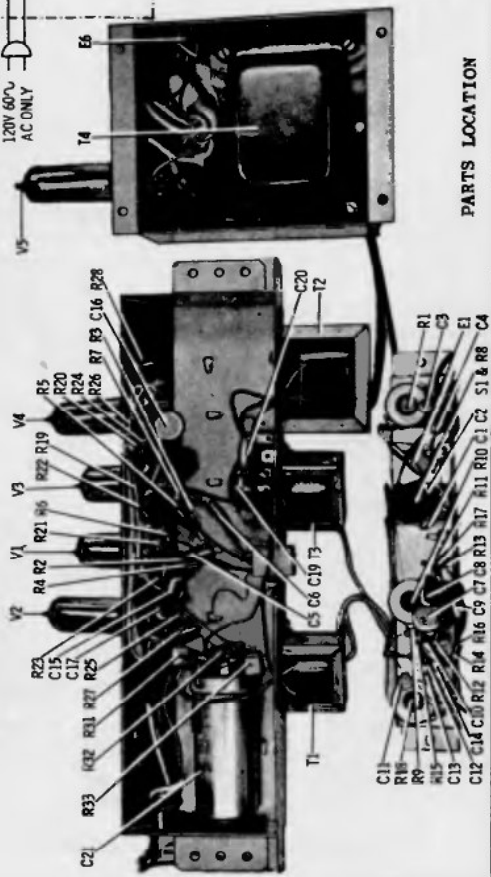

MOTOROLA
MODEL SH21 CHASSIS
HS-829 AUDIO AMP
HS-830 PWR SUPPLY

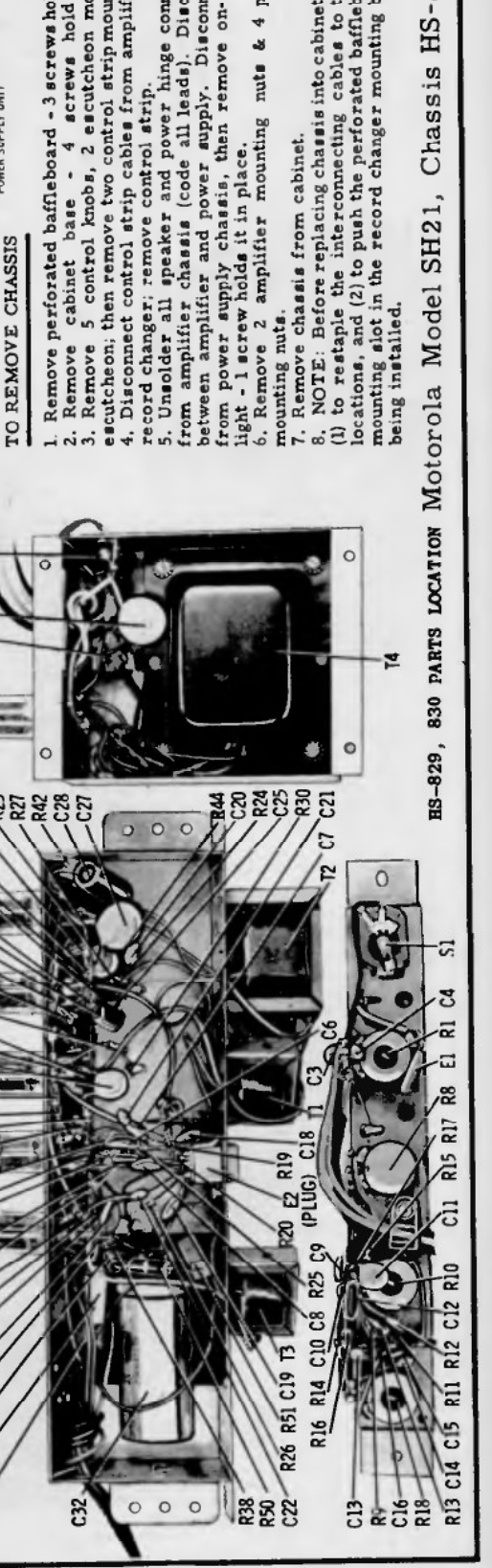
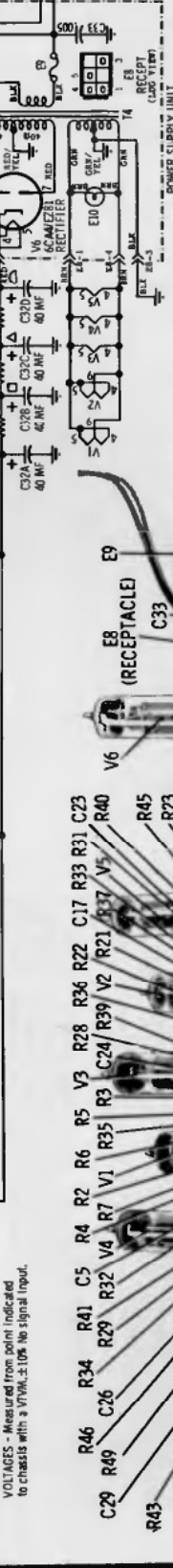
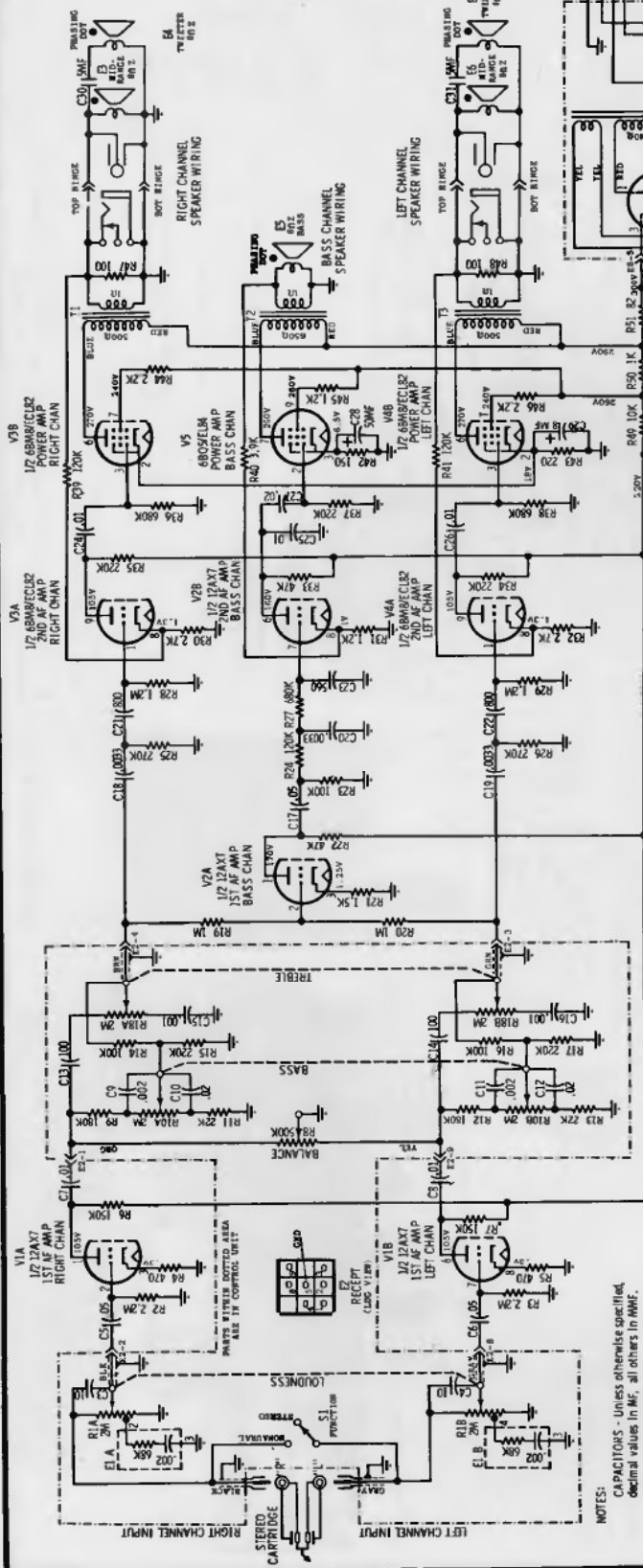

TO REMOVE CHASSIS

1. Remove perforated baffleboard - 3 screws hold it in place.
2. Remove cabinet base - 4 screws hold it in place.
3. Remove 5 control knobs, 2 escutcheon mounting nuts, escutcheon; then remove two control strip mounting screws.
4. Disconnect control strip cables from amplifier chassis & record changer; remove control strip.
5. Unsolder all speaker and power hinge connecting leads from amplifier chassis (code all leads). Disconnect cable between amplifier and power supply. Disconnect AC cord from power supply chassis, then remove on-off indicator light - 1 screw holds it in place.
6. Remove 2 amplifier mounting nuts & 4 power supply mounting nuts.
7. Remove chassis from cabinet.
8. NOTE: Before replacing chassis into cabinet, remember: (1) to restrap the interconnecting cables to their original locations, and (2) to push the perforated baffleboard into its mounting slot in the record changer mounting board as it is being installed.

HS-829, 830 PARTS LOCATION Motorola Model SH21, Chassis HS-829, HS-830

MOTOROLA INC.

MODEL SH22

STEREO

**CHASSIS HS-831 AUDIO AMP
HS-832 PWR SUPPLY**

INFORMATION

Motorola Model SH22, Chassis HS-831, HS-832

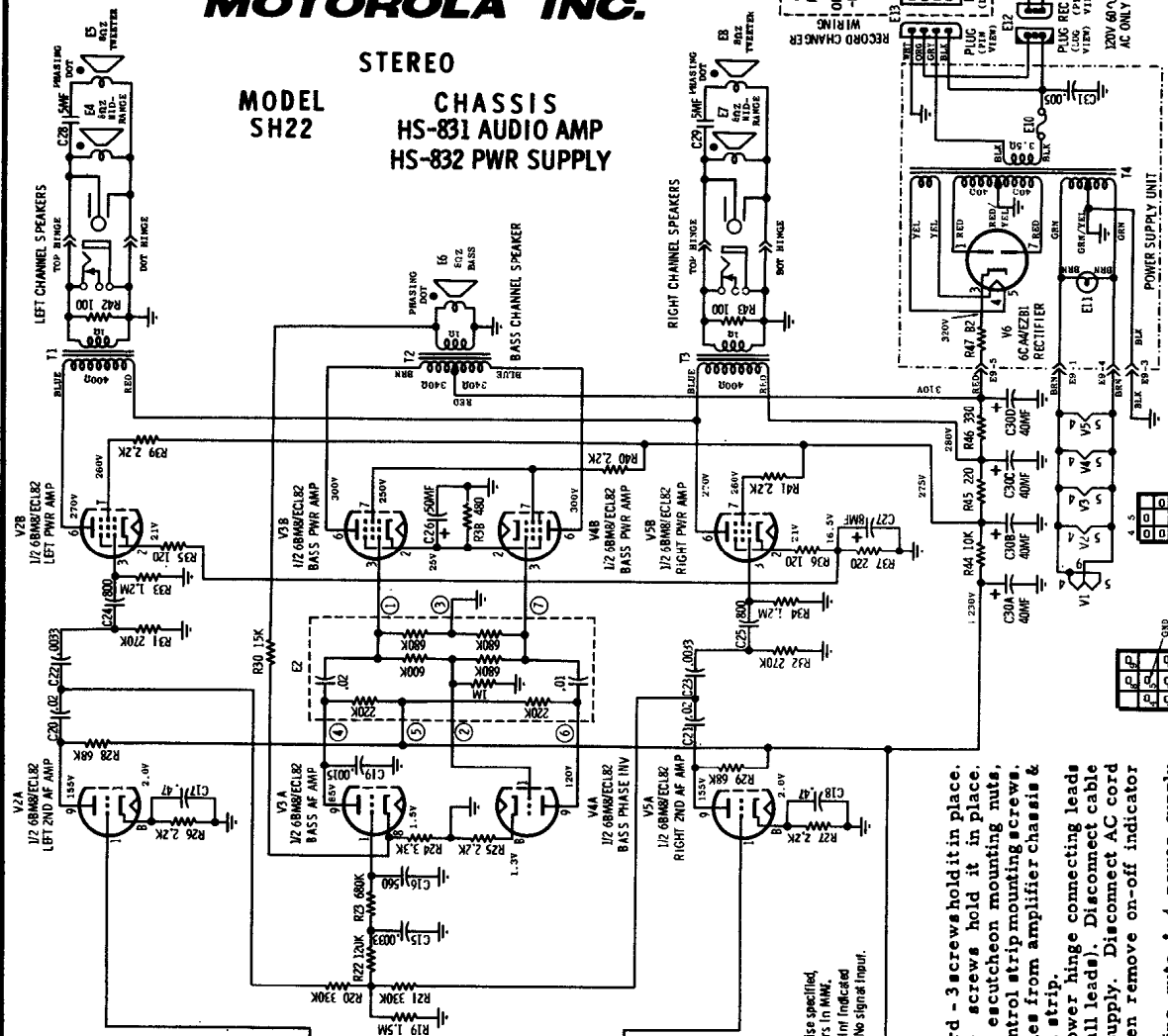

TO REMOVE RECORD CHANGER

1. Remove cabinet base - 4 screws hold it in place.
2. Disconnect power and phono input plugs connected to record changer.
3. Turn the 2 record changer mounting screws clockwise down flush with the changer base.
4. Turn the mounting clips, located at the ends of the mounting screws, so they are parallel with the mounting screws.

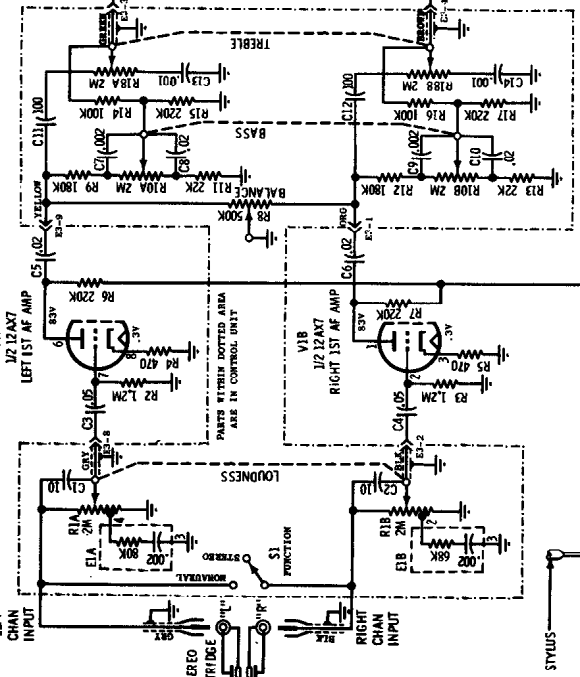

NOTES:
CAPACITORS - Unless otherwise specified, decimal values in MF, all others in MMF.
VOLTAGES - Measured from point indicated to chassis with a VTVM, 50K No signal input.

TO REMOVE CHASSIS

1. Remove perforated baffleboard - 3 screws hold it in place.
2. Remove cabinet base - 4 screws hold it in place.
3. Remove 5 control knobs, 2 escutcheon mounting nuts, escutcheon; then remove two control strip mounting screws.
4. Disconnect control strip cables from amplifier chassis & record changer; remove control strip.
5. Unsolder all speaker and power hinge connecting leads from amplifier chassis (code all leads). Disconnect cable between amplifier and power supply. Disconnect AC cord from power supply chassis, then remove on-off indicator light - 1 screw holds it in place.
6. Remove 2 amplifier mounting nuts & 4 power supply mounting nuts.
7. Remove chassis from cabinet.
8. NOTE: Before replacing chassis into cabinet, remember: (1) to restaple the interconnecting cables to their original locations, and (2) to push the perforated baffleboard into its mounting slot in the record changer mounting board as it is being installed.

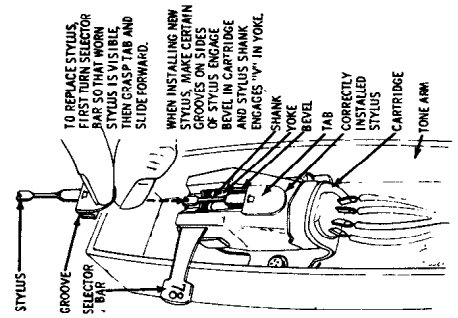

- STYLUS PART NUMBERS**
- .7 MIL SAPPHIRE-MOTOROLA 99C4036A04
 - .7 MIL DIAMOND-MOTOROLA 99C4036A05
 - 3 MIL SAPPHIRE-MOTOROLA 99C4036A08
- STYLUS REPLACEMENT**

VOLUME R-21, MOST-OFTEN-NEEDED 1961 RADIO SERVICING INFORMATION

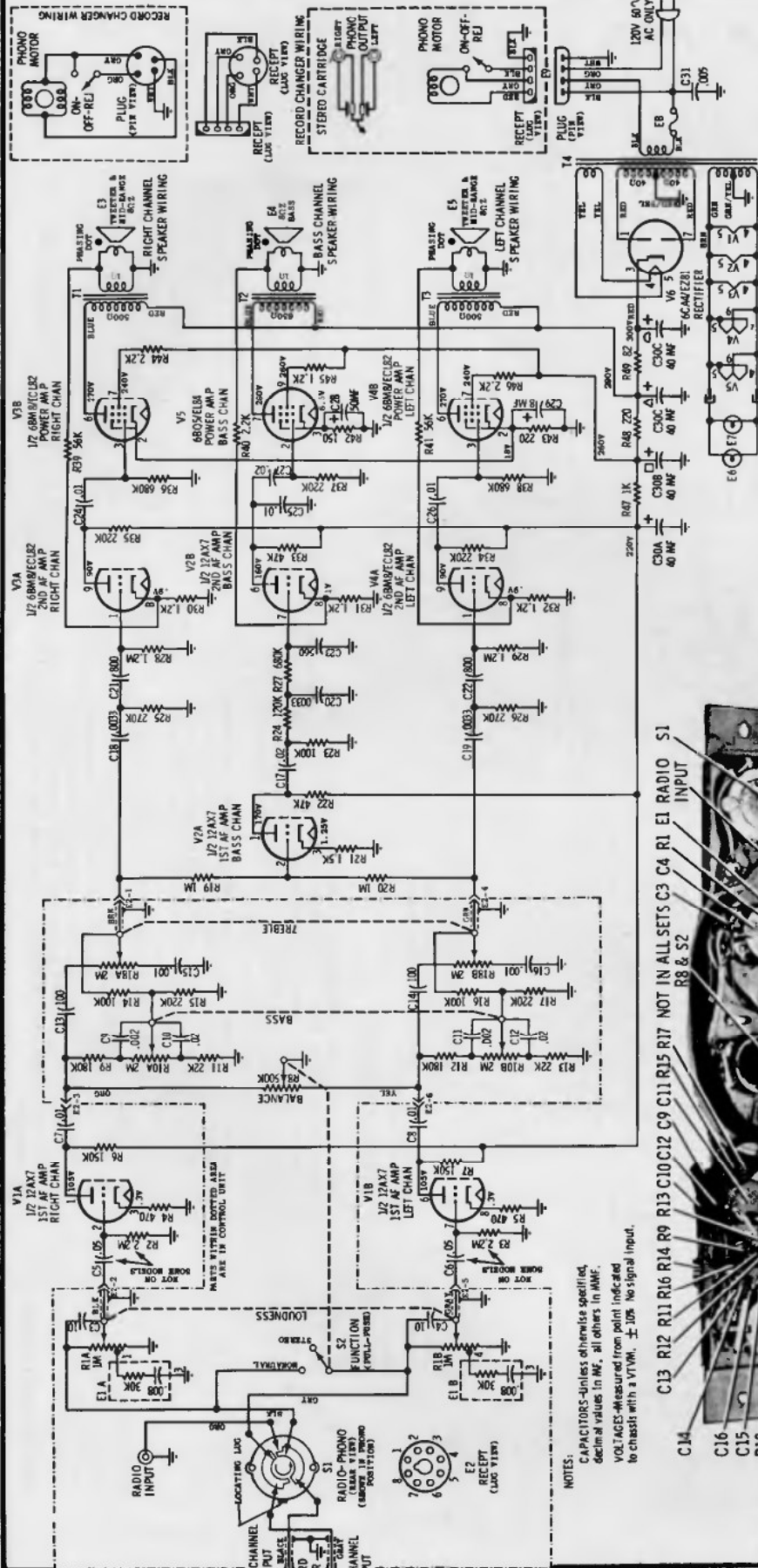

PRODUCTION CHANGES

Chassis Coding	Changes
HS-833A	Original chassis
HS-833B	TO REDUCE NOISY LOUDNESS CONTROL OPERATION: C-5 (.05 mf), C-6 (.05 mf), R-2 (470K), and R-3 (470K) added.
HS-833C	TO ADD BASS BOOST: R-2 and R-3 (both 470K) changed to 2.2 meg.
HS-833D	TO REDUCE LEAKAGE CURRENT: C-31 (.05 mf) changed to .005 mf.

MOTOROLA INC.
 MODEL CHASSIS
 SK40 HS-833
 SK40-1 HS-833
 SK41 HS-833

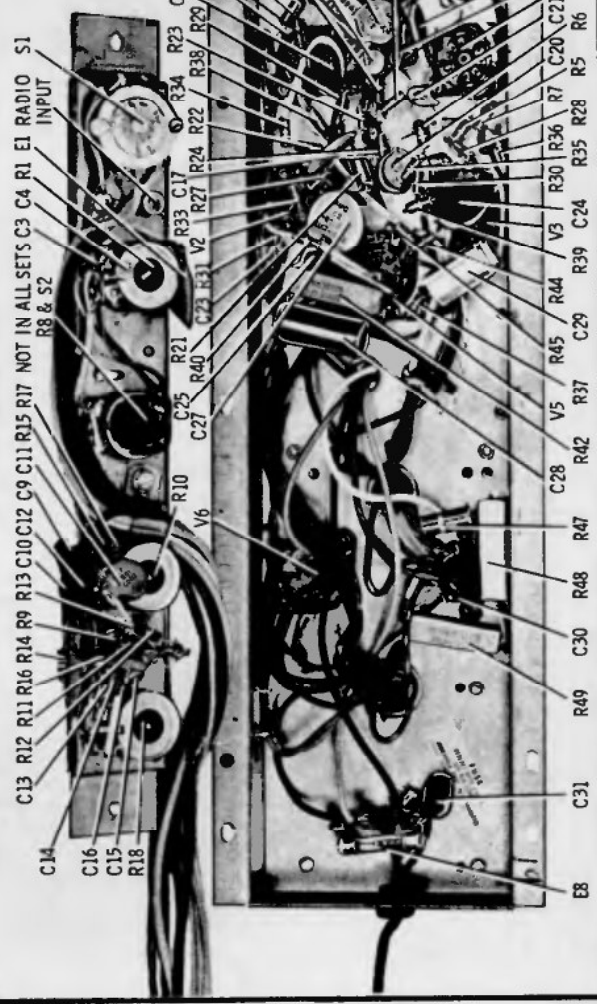

NOTES:
 CAPACITORS—unless otherwise specified, decimal values in MF, all others in MMF.
 VOLTAGES—measured from point indicated to chassis with a VTVM. ± .05. No signal input.

HS-833A PARTS LOCATION (SEE PRODUCTION CHANGES)

MOTOROLA

MODEL SK43
SK43-1

CHASSIS HS-835
HS-835

INFORMATION

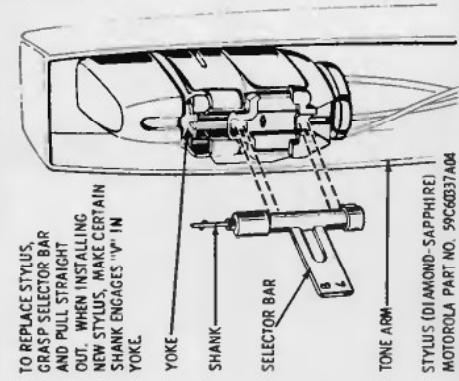
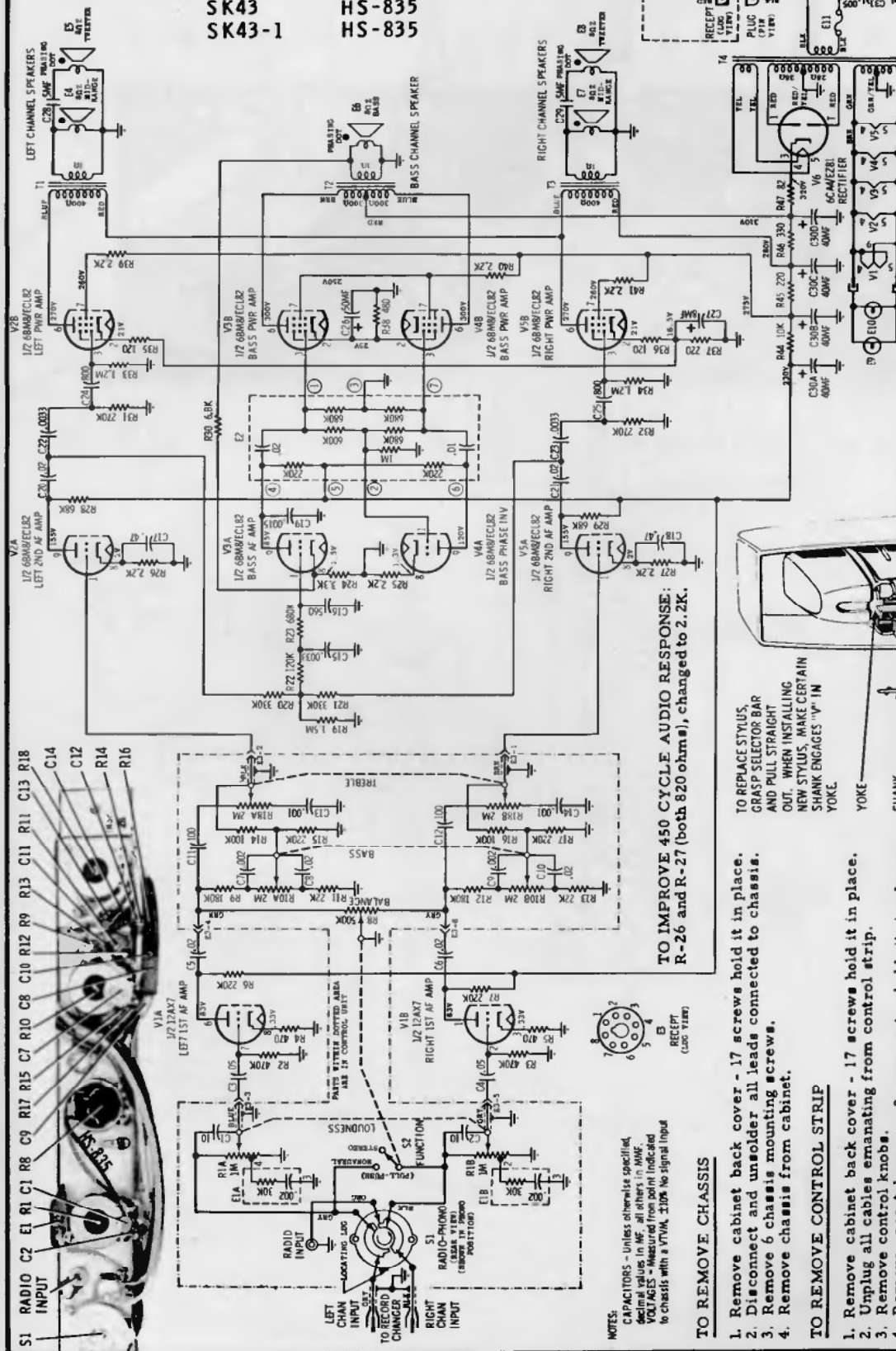

TO IMPROVE 450 CYCLE AUDIO RESPONSE:
R-26 and R-27 (both 820 ohm \pm), changed to 2.2K.

NOTES:
CAPACITORS - unless otherwise specified, in MFD. All others in PFD.
VOLTAGE IS MEASURED FROM POINT INDICATED to chassis with a VTVM. 110V No signal input

TO REMOVE CHASSIS

1. Remove cabinet back cover - 17 screws hold it in place.
2. Disconnect and unsolder all leads connected to chassis.
3. Remove 6 chassis mounting screws.
4. Remove chassis from cabinet.

TO REMOVE CONTROL STRIP

1. Remove cabinet back cover - 17 screws hold it in place.
2. Unplug all cables emanating from control strip.
3. Remove control knobs.
4. Remove escutcheon - 2 cup nuts hold it in place.
5. Remove 2 control strip mounting screws and remove control strip.

TO REMOVE RECORD CHANGER

1. Turn the 2 changer mounting screws clockwise until flush with the changer base.
2. Remove cabinet back cover - 17 screws hold it in place.
3. Unplug power and audio cables from record changer.
4. Turn the mounting clips, located at the ends of the mounting screws, so they are parallel with the mounting screws, then lift changer out of cabinet.

STYLUS REPLACEMENT SK43-1 SERIES

MOTOROLA

MODEL	CHASSIS
SF15	HS-860
SF15-1	HS-898
SF15-2	HS-860

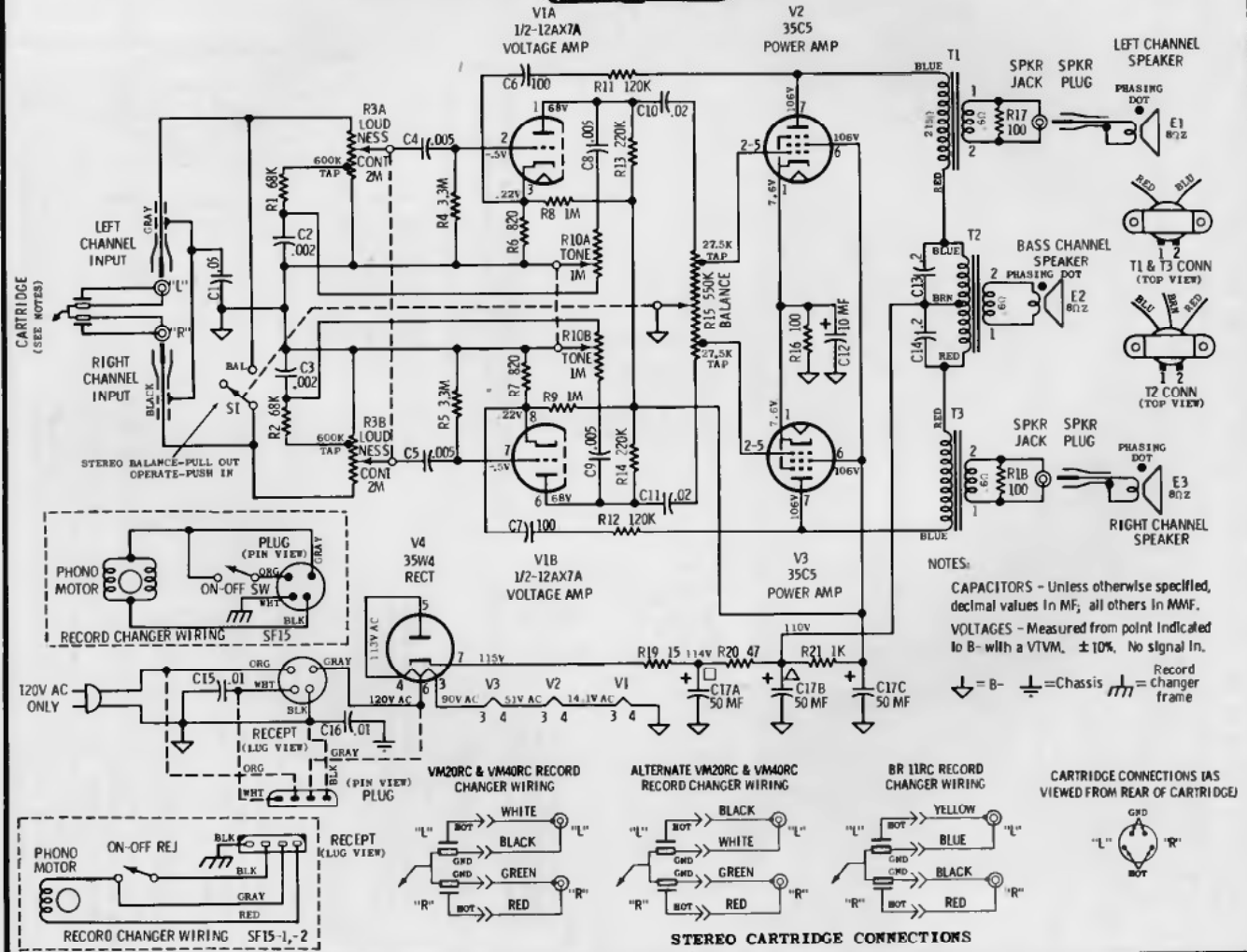
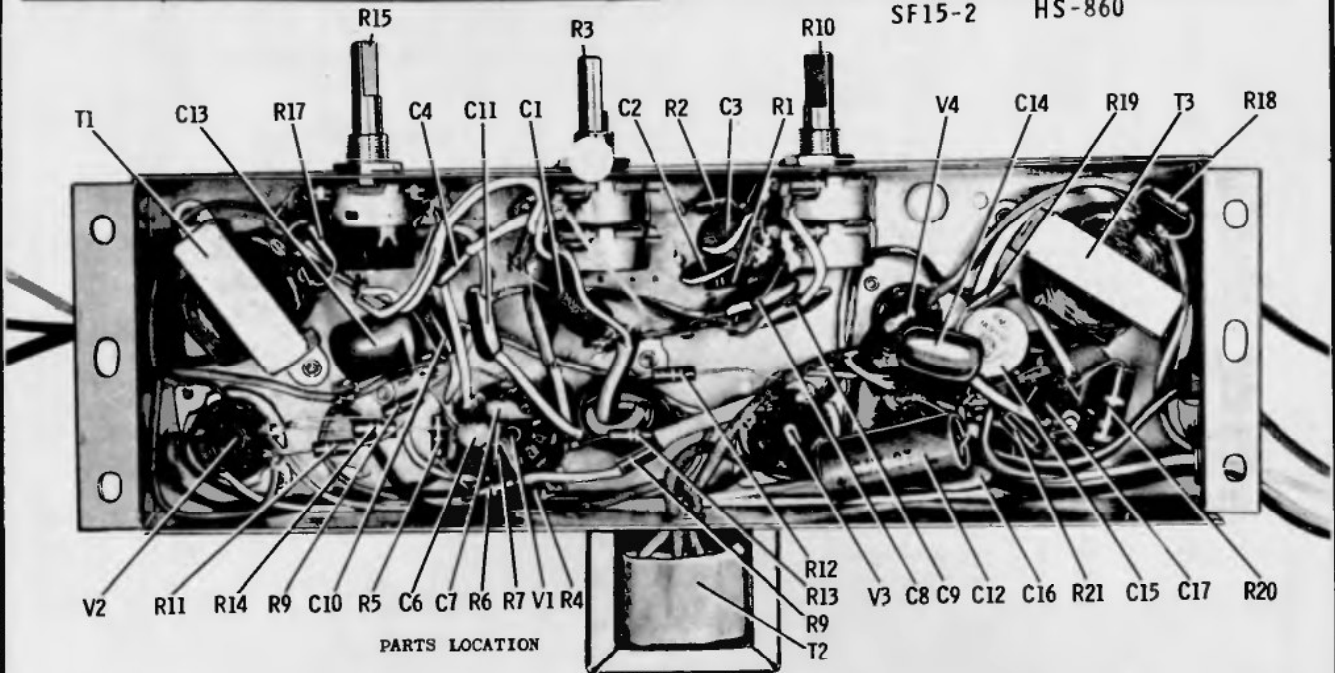

MOTOROLA INC.

MODEL
SH19

CHASSIS
HS-861 AUDIO AMP
HS-869 PWR SUPPLY

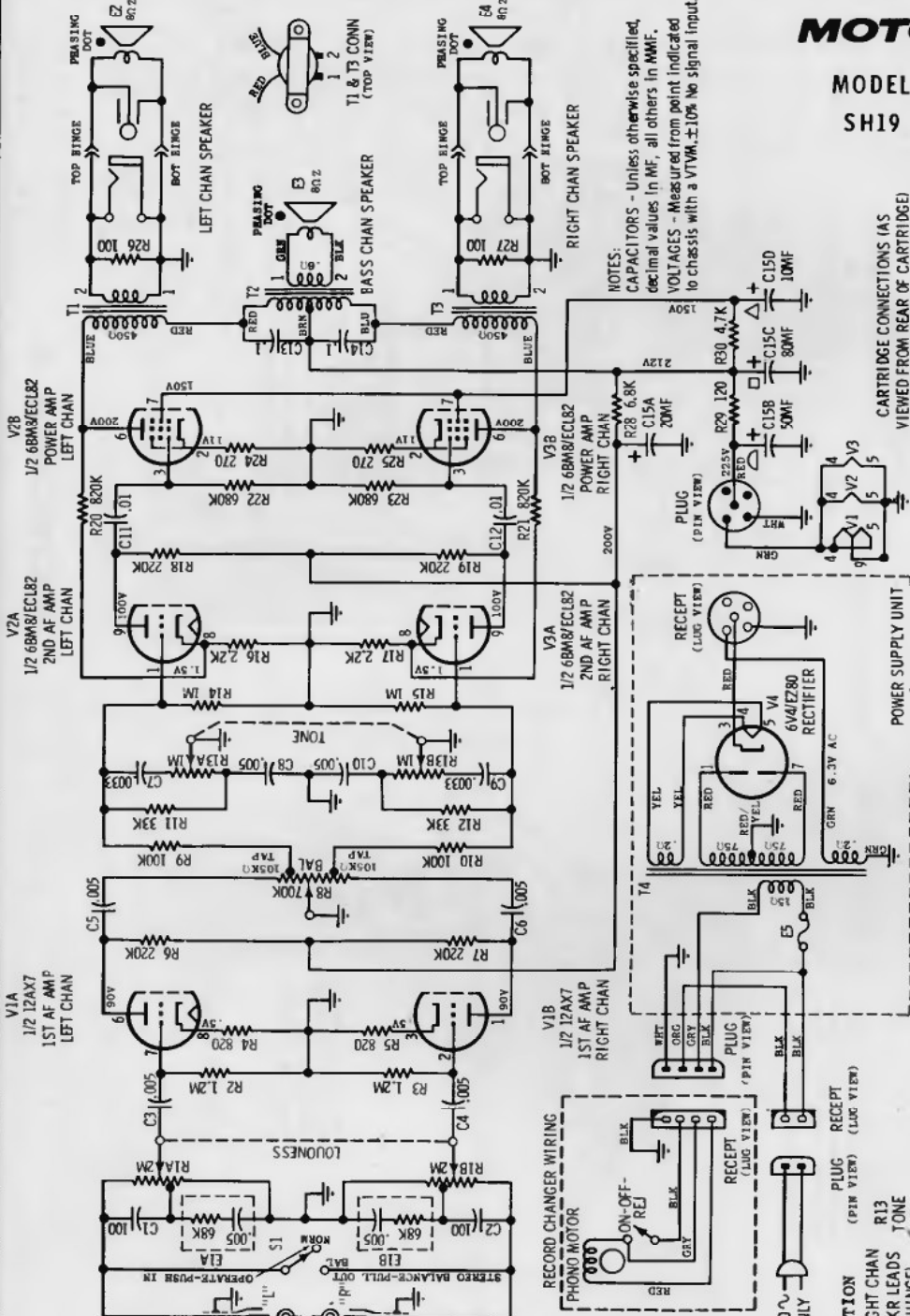

NOTES:
CAPACITORS - Unless otherwise specified, decimal values in MF, all others in MMF.
VOLTAGES - Measured from point indicated to chassis with a VTVM $\pm 10\%$ No signal input.

CARTRIDGE CONNECTIONS (AS VIEWED FROM REAR OF CARTRIDGE)

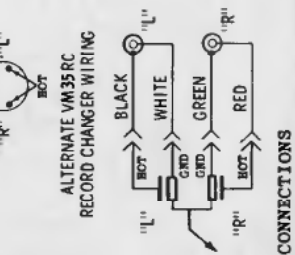

STEREO CARTRIDGE CONNECTIONS

TO REPLACE STYLUS, FIRST TURN SELECTOR BAR SO THAT WORN GROOVES ON SIDES OF STYLUS IS VISIBLE. THEN GRASP TAB AND SLIDE FORWARD. ENGAGES "V" IN YOKE.

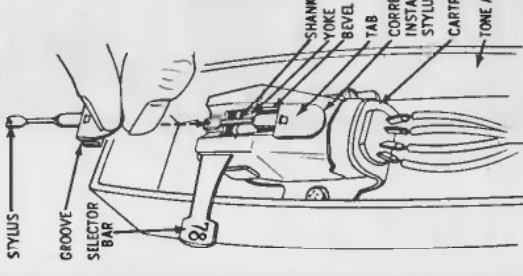

STYLUS PART NUMBERS
 .7 MIL SAPPHIRE-MOTOROLA 59C60336A04
 .7 MIL DIAMOND-MOTOROLA 59C60336A05
 3 MIL SAPPHIRE-MOTOROLA 59C60336A03

HS-861, 869 PARTS LOCATION



R-21, MOST-OFTEN-NEEDED 1961 RADIO SERVICING INFORMATION

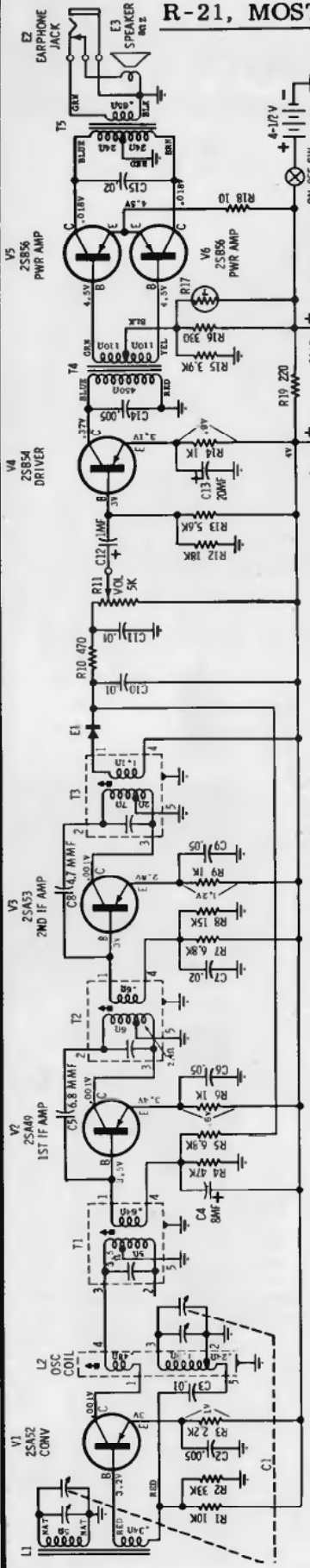

PRINTED CIRCUIT BOARD

NOTES:
 CAPACITORS - Unless otherwise specified, decimal values in MF, all others in MMF.
 VOLTAGES - Measured from point indicated to ground with a VTVM, ± 10%. No signal in.
 ZERO SIGNAL CURRENT - 4.8M A (MIN VOL)

TUNING RANGE - 532KC TO 1620KC
IF - 455KC

⊕ = GROUND

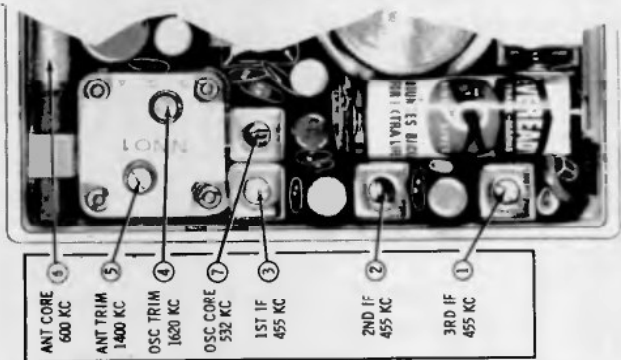
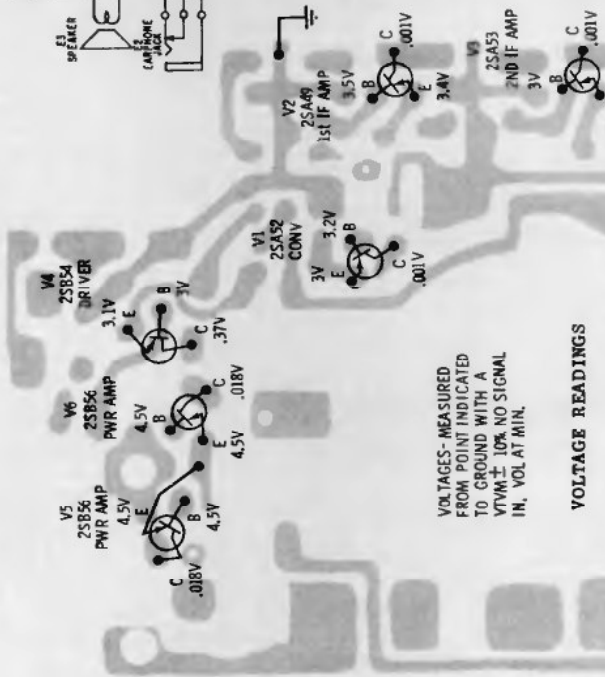
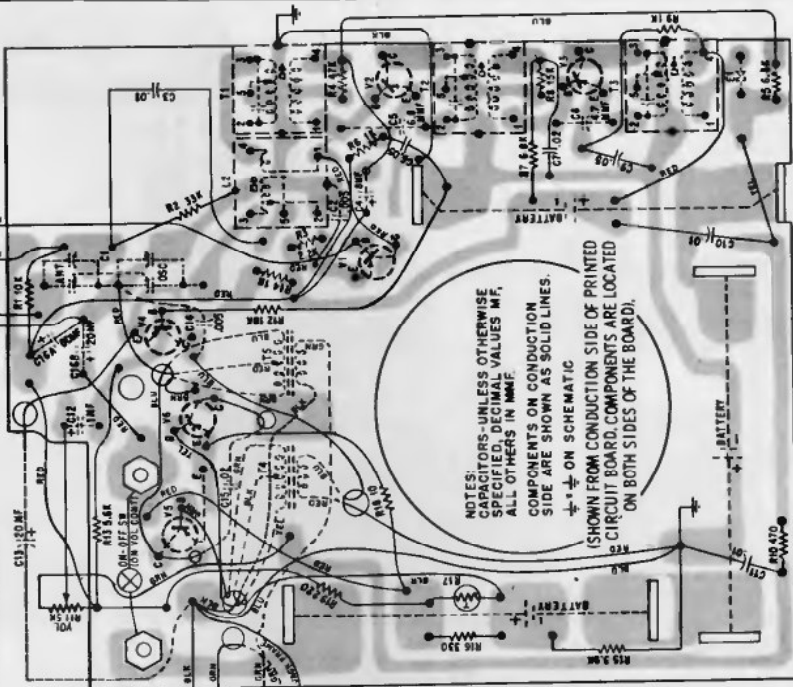

MOTOROLA
 MODEL CHASSIS X21W HS-876

Packard Bell

TABLE RADIO 5R8
CLOCK RADIO 5RC8

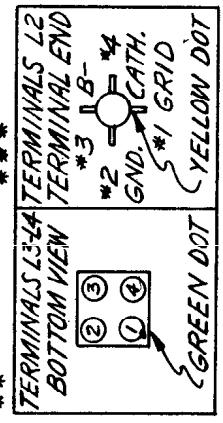
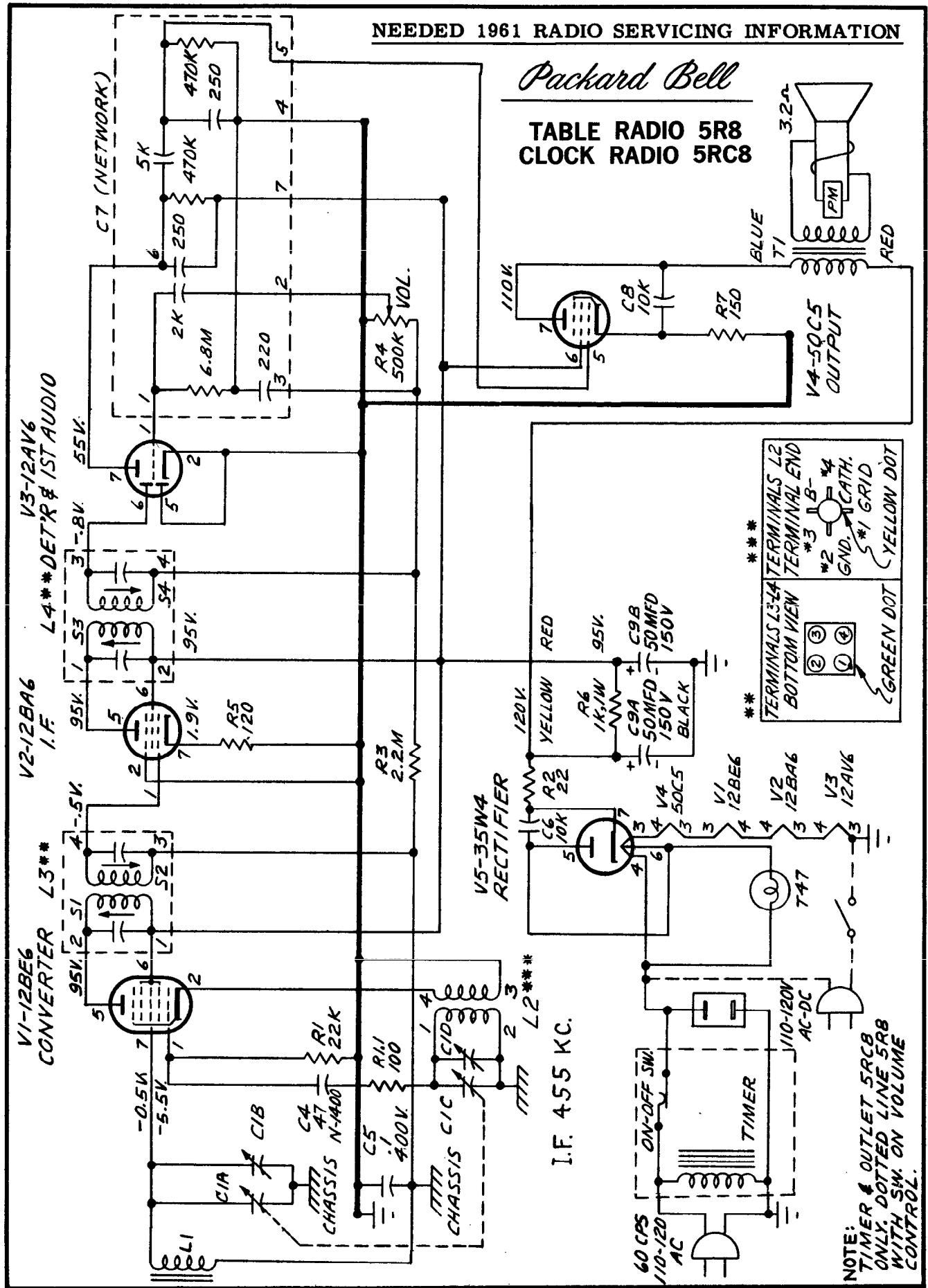

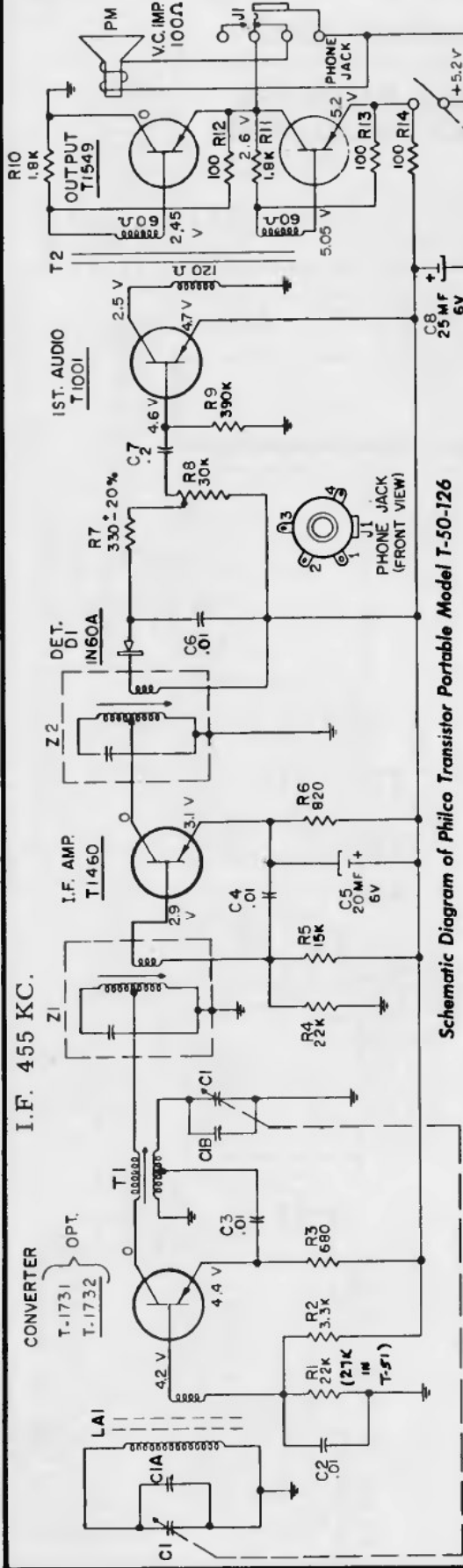

Schematic Diagram of Philco Transistor Portable Model T-50-126

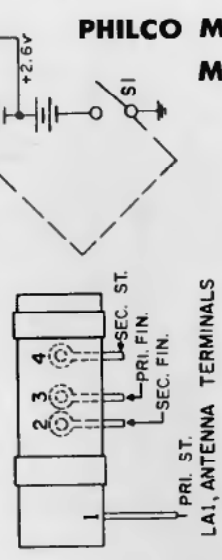

NOTES:
 ALL RESISTORS 1/2W, 10%, CARBON.
 VOLTAGES MEASURED TO GROUND WITH
 A 20,000 Ω/VOLT METER UNDER
 NO SIGNAL CONDITION
 COIL RESISTANCES READ WITH COIL
 IN CIRCUIT.

PANEL LEAD CONNECTIONS

Black lead from negative battery contact to switch lug #7.
 Bare wire from switch lug #6 to ground tab of volume control
 and to frame of gang.
 Red lead from positive battery contact to switch lug #5.
 Red lead from switch lug #4 to Panel.
 White lead from voltage supply center-tap to J1, lug #1.
 Blue lead from J1, lug #3, to speaker.
 White lead from J1, lug #2 to panel L2.

PHILCO Models T-50-126, T-51-124

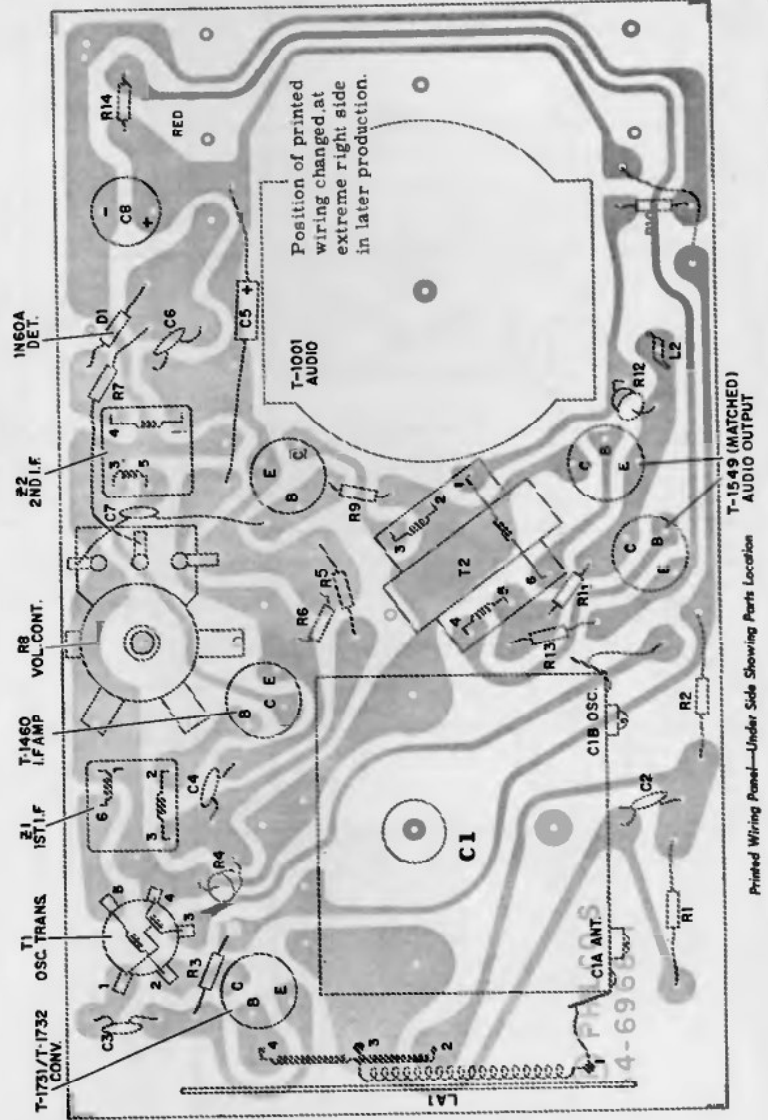

Printed Wiring Panel—Under Side Showing Parts Location

VOLUME R-21, MOST-OFTEN-NEEDED 1961 RADIO SERVICING INFORMATION

PHILCO MODEL T-52, CODE 124, and CLOCK RADIO MODEL TC-57

These two models use identical perma-circuit panel assembly, but the switch of T-52 is manually operated.

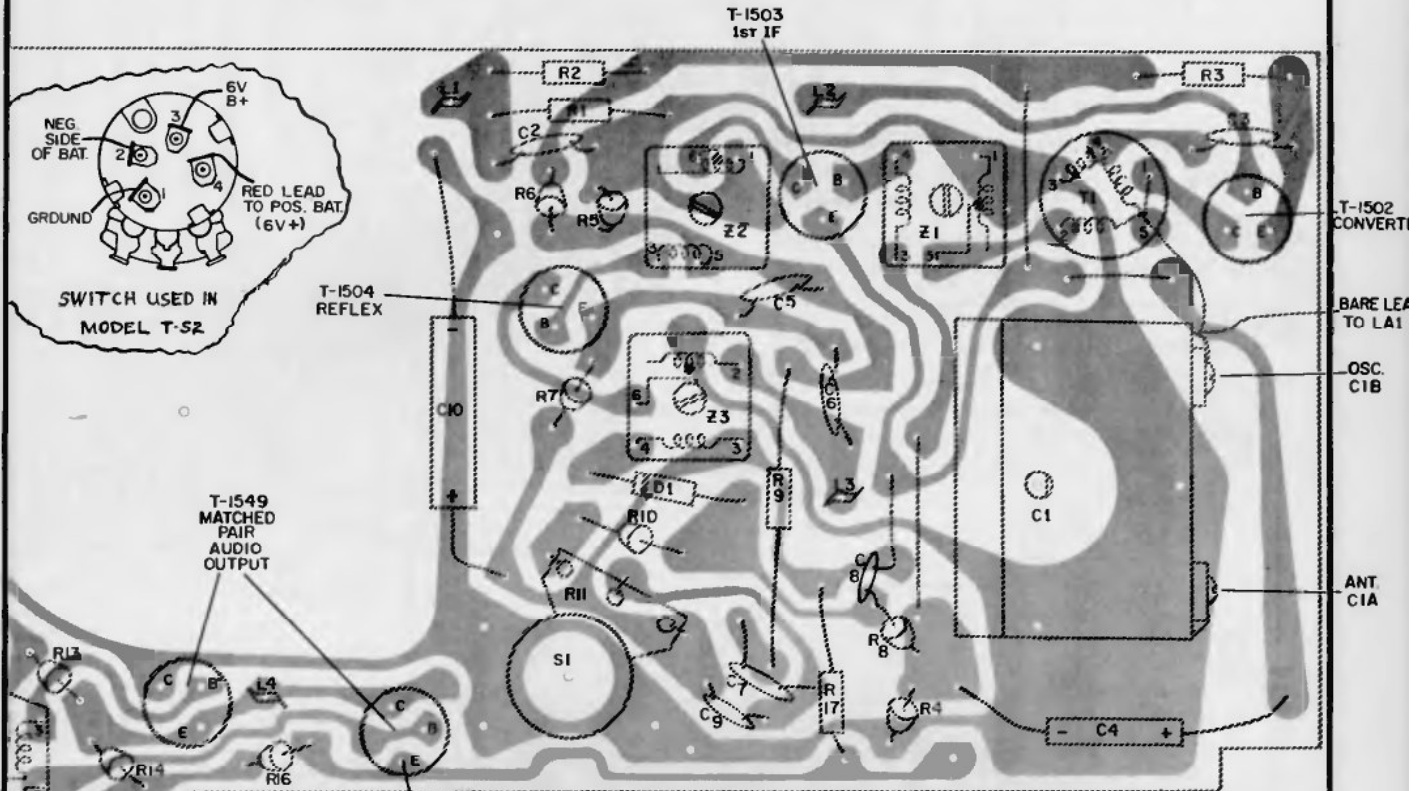

Composite View, Bottom of Panel

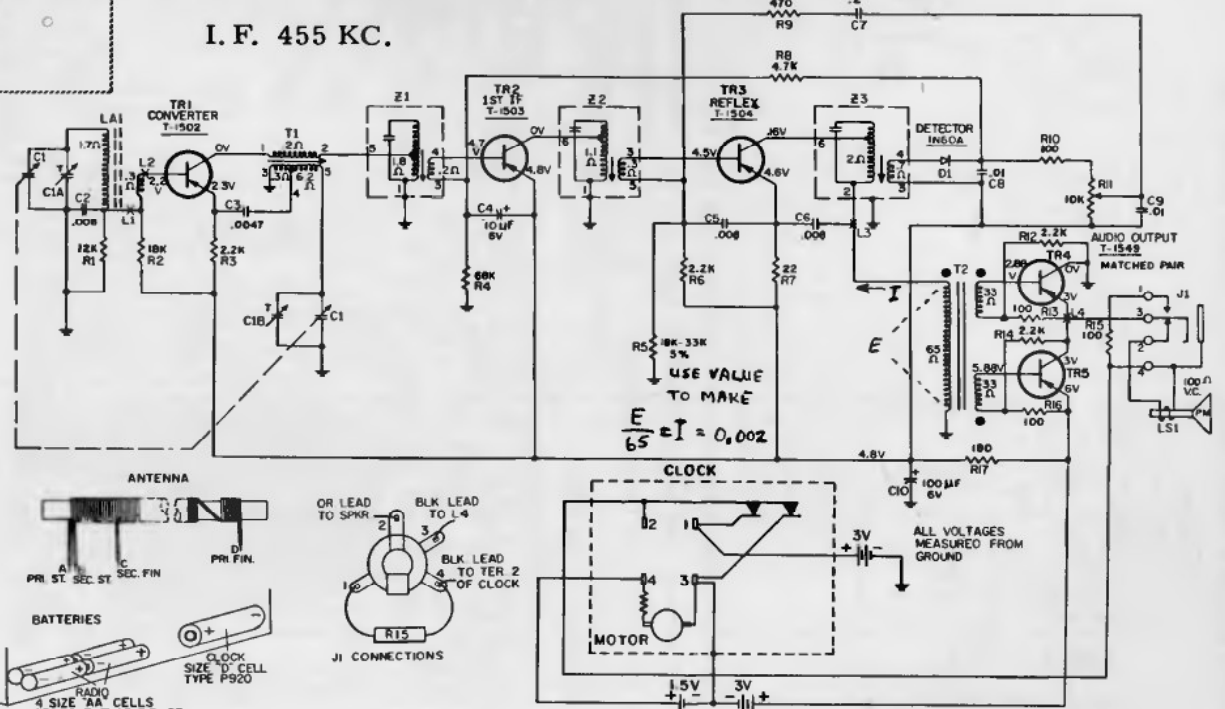

Schematic Diagram, Model TC-57

PHILCO PORTABLE RADIO TRANSISTOR MODEL T-62, CODE 124

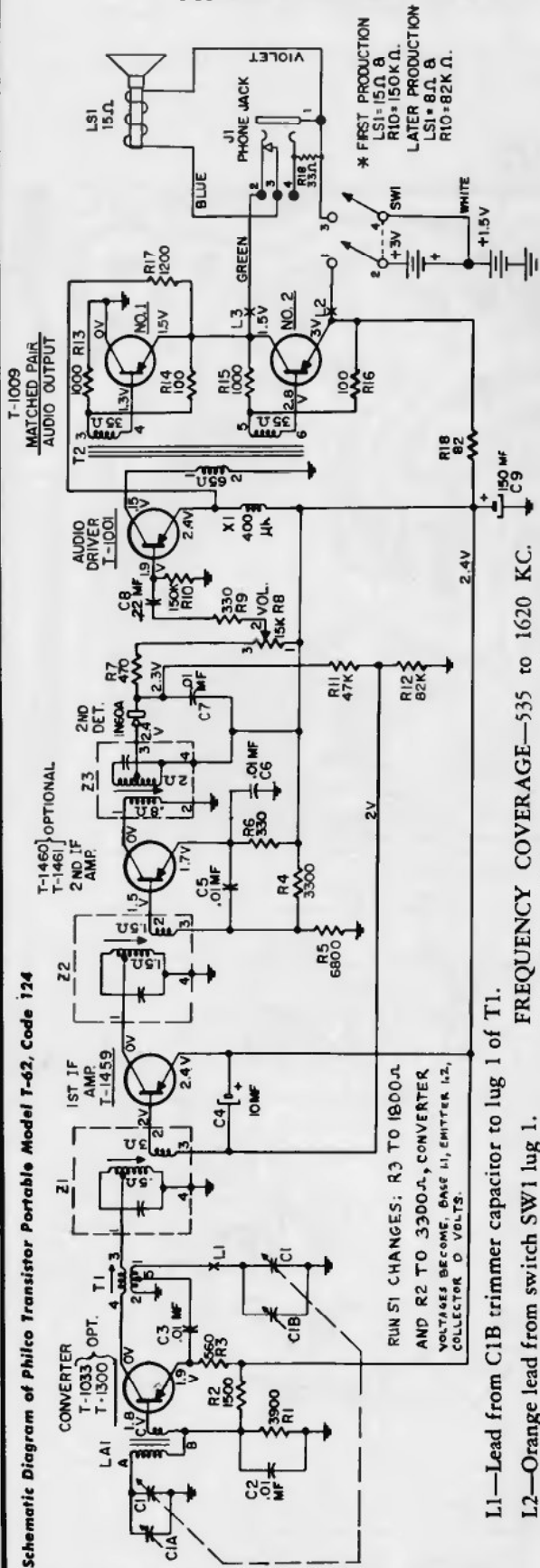

L1—Lead from C1B trimmer capacitor to lug 1 of T1.
 L2—Orange lead from switch SW1 lug 1.
 L3—Green lead from phone jack.

SERVICE NOTES

When signal tracing, inject signal at transistor collector and limit input to keep signal across speaker below .6 volt.
 Normally, the transistors should be the last item suspected. If C9 opens serious audio oscillation will result.

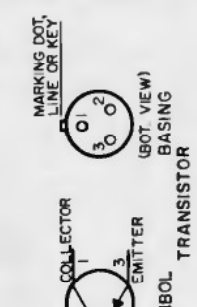

PRINTED-WIRE PANEL REMOVAL

1. Remove the snap-on back of the cabinet and the batteries.
2. Remove the tri-mount fastener next to the battery clips.
3. Carefully spread the sides of the cabinet to free the panel from each of the 4 slotted cabinet supports.
4. Withdraw the panel assembly by sliding it toward the speaker end of the cabinet to free the tuning knob.

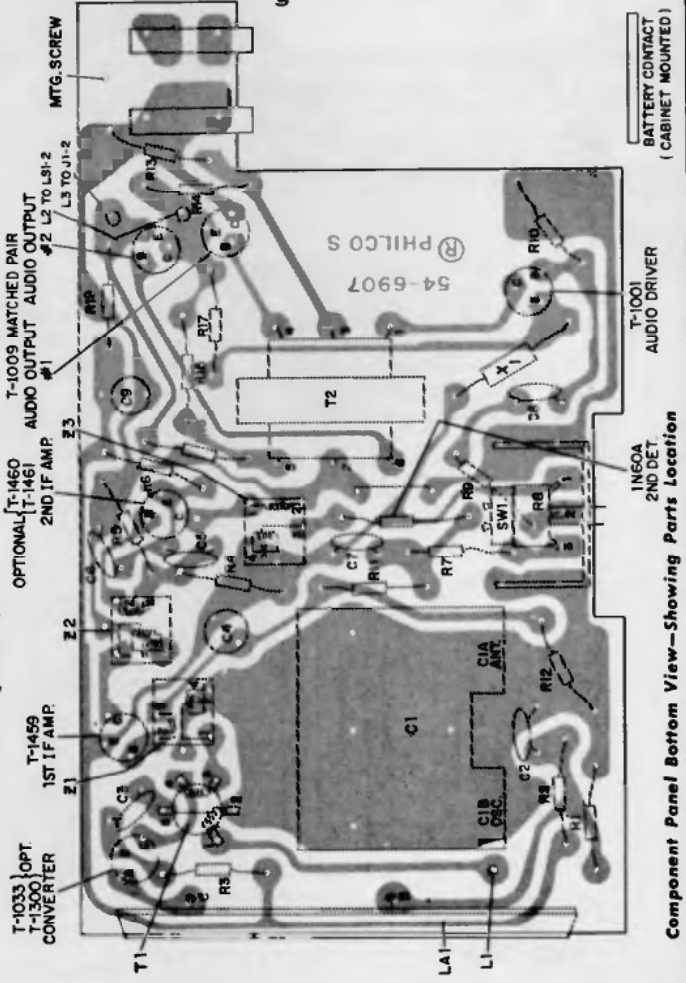

Component Panel Bottom View—Showing Parts Location

PHILCO PORTABLE RADIO TRANSISTOR MODEL T-66, CODE 124

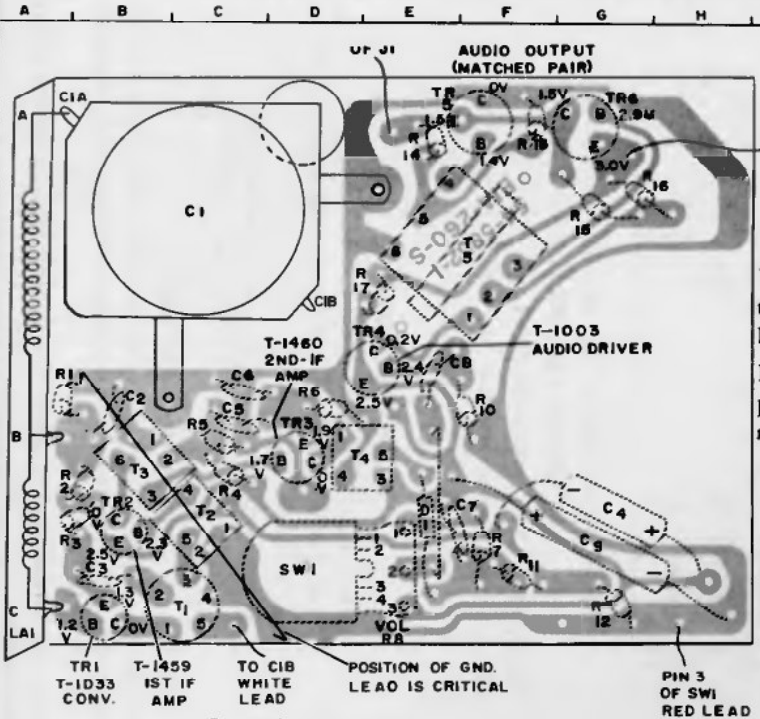

NOTE:
 PIN 2 OF SWI TO POS. TERM. YEL. LEAD
 PIN 1 OF SWI YEL. LEAD
 PIN 4 OF SWI TO NEG. TERM. RED LEAD
 PIN 3 OF SWI RED LEAD

SERVICE NOTES

When signal tracing, inject signal at transistor collector and limit input to keep signal across speaker below .6 volt.

Normally, the transistors should be the last item suspected. If C9 opens serious audio oscillation will result.

NOTE: Panel Removal

Before panel can be removed from cabinet, a screw located next to the 2nd I-F transformer (C4 graph location) must be removed. Then depress clips on each side of cabinet. Speaker will remain in cabinet.

Composite Bottom View

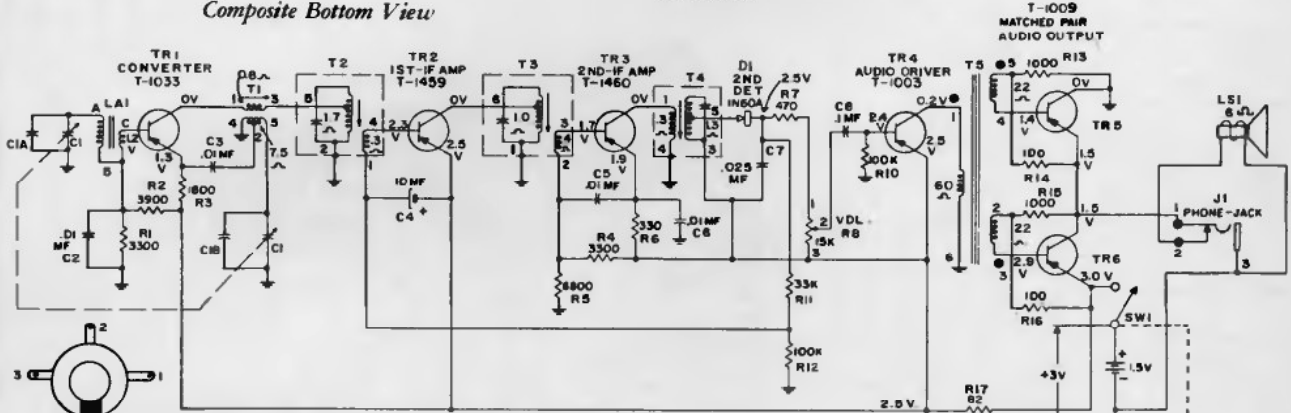

Schematic Diagram of Model T-66, Code 124

ALL VOLTAGES MEASURED FROM B- BATTERY CURRENT WITH NO SIGNAL, VOL. CONTROL AT MIN. IS 11 MA.

T-66, Code 126: TR1, Converter Transistor changed to T-1877, T2, 1st i-f Transformer changed to Part No. 32-4800-2.

ALIGNMENT CHART

STEP	SIGNAL GENERATOR		RADIO		ADJUST
	CONNECTION TO RADIO	DIAL SETTING	DIAL SETTING	SPECIAL INSTRUCTIONS	
1	Connect signal generator through a .1-uf. condenser to ant. section of gang.	455 kc.	Tuning gang fully open.	Adjust for maximum output in order given.	T4—3rd I-F T3—2nd I-F T2—1st I-F
2	Use radiating loop. (See NOTE 1 below)	600 kc.	600 kc.	Adjust for maximum output. Rock tuning gang while making this adjustment.	T1—osc. core
3	Same as step 2.	1620 kc.	1620 kc. (Tuning gang fully open)	Adjust for maximum output.	C1B—osc. trimmer
4	Same as step 2.	1400 kc.	1400 kc.	Adjust for maximum output.	C1A—antenna trimmer
5	Repeat steps 2, 3 and 4 until no further improvement is obtained. Always stop on step 4.				

NOTE 1. Use a 6-to-8-urn, 6-inch-diameter loop made up of insulated wire. Connect to generator terminals, and place about one foot from radio loop.

PHILCO PORTABLE RADIO TRANSISTOR MODEL T-70, CODE 124

AUDIO OUTPUT
T-1008
MATCHED PAIR

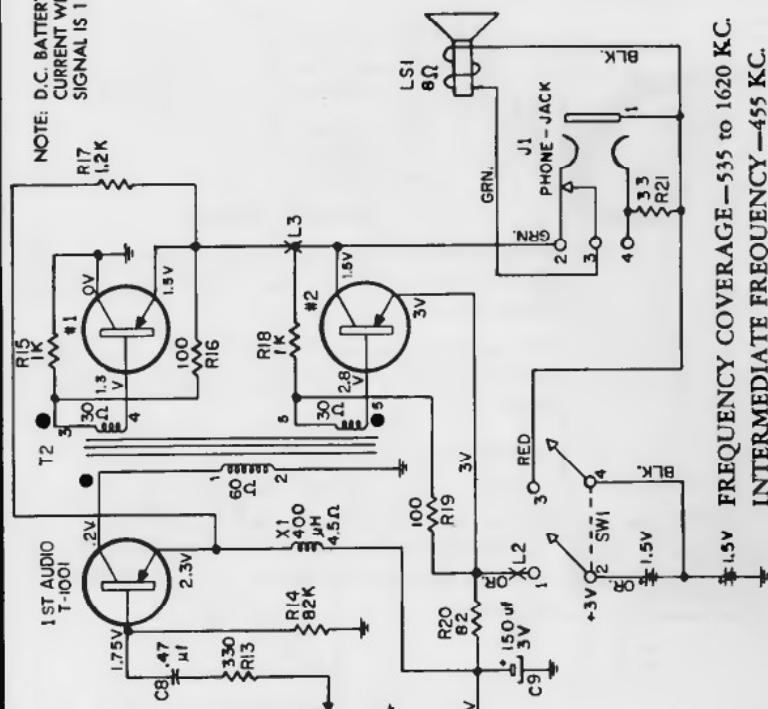

TERMINAL LUG IDENTIFICATION
L1—Lead from CIB Trimmer Capacitor Lug 1 of T1
L2—Green Lead from Switch SW1, Lug 1
L3—Green Lead from Phono Jack

SERVICE NOTES

When signal tracing, inject signal at transistor collector and limit input to keep signal across speaker below .6 volt.
Normally, the transistors should be the last item suspected. If C9 opens serious audio oscillation will result.

SCHEMATIC NOTES

All voltages taken with a Philco Meter Model 8102, 20,000 ohms per volt. All measurements taken between ground and points indicated. Coil resistances read with coil in circuit.
●—Black dots located at (T2) Audio Transformer indicates phasing polarity of transformer.

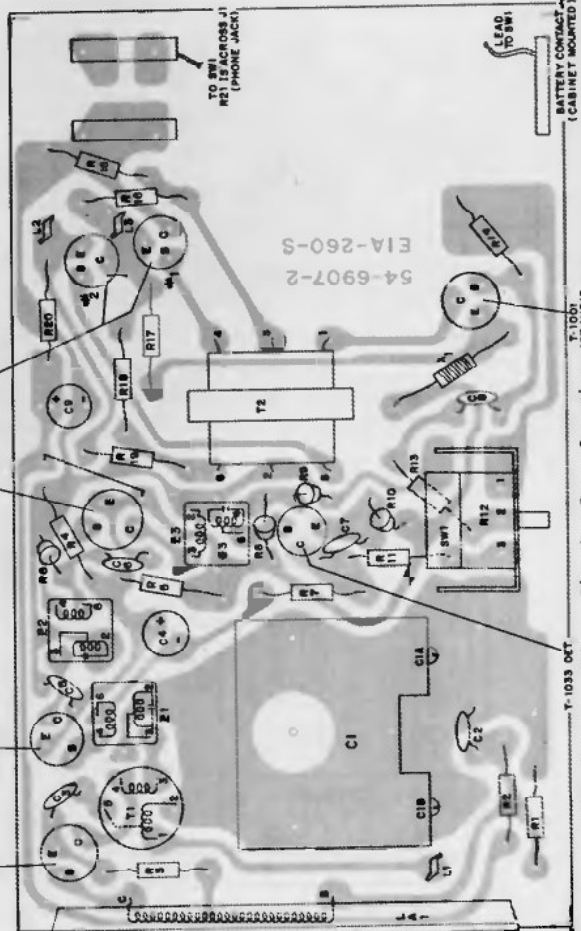

Component Panel Bottom View—Showing Parts Location

PHILCO PORTABLE RADIO TRANSISTOR MODEL T-74, CODE 124

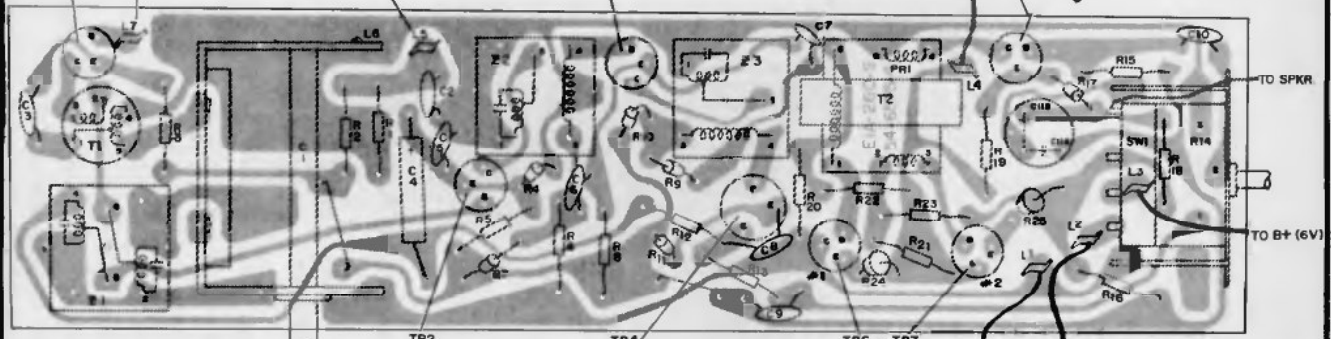
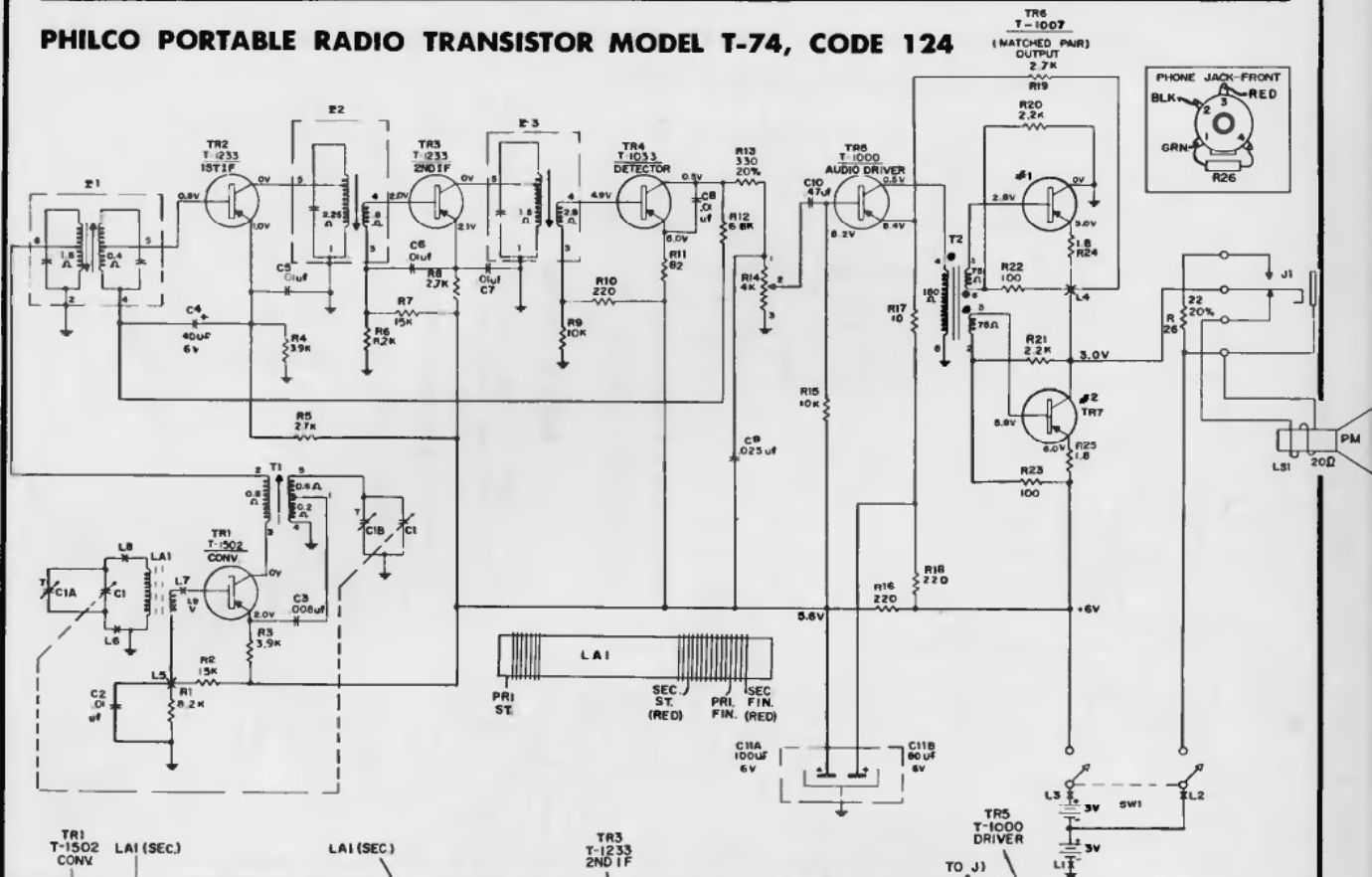

Bottom Composite View of Perma-Circuit Panel

ALIGNMENT CHART

STEP	SIGNAL GENERATOR		RADIO		ADJUST
	CONNECTION TO RADIO	DIAL SETTING	DIAL SETTING	SPECIAL INSTRUCTIONS	
1	Connect signal generator through a .1-uf. condenser to ant. section of gang.	455 kc.	Tuning gang fully open.	Adjust for maximum output in order given.	Z3—3rd i-f Z2—2nd i-f Z1—1st i-f
2	Use radiating loop. (See NOTE 1 below)	600 kc.	600 kc.	Adjust for maximum output. Rock tuning gang while making this adjustment.	T1—osc. core
3	Same as step 2.	1620 kc.	1620 kc. (Tuning gang fully open)	Adjust for maximum output.	C1B—osc. trimmer
4	Same as step 2.	1400 kc.	1400 kc.	Adjust for maximum output.	C1A—antenna trimmer
5	Repeat steps 2, 3 and 4 until no further improvement is obtained. Always stop on step 4.				

NOTE 1. Use a 6-to-8-turn, 6-inch-diameter loop made up of insulated wire. Connect to generator terminals, and place about one foot from radio loop.

PHILCO PORTABLE RADIO MODEL T-76, CODE 124

PHILCO PORTABLE RADIO TRANSISTOR MODEL T-76, CODE 124

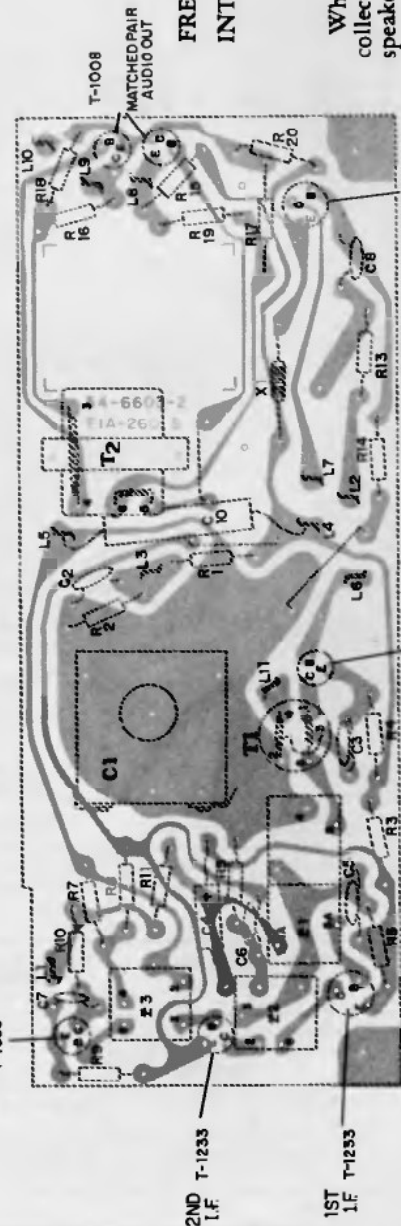
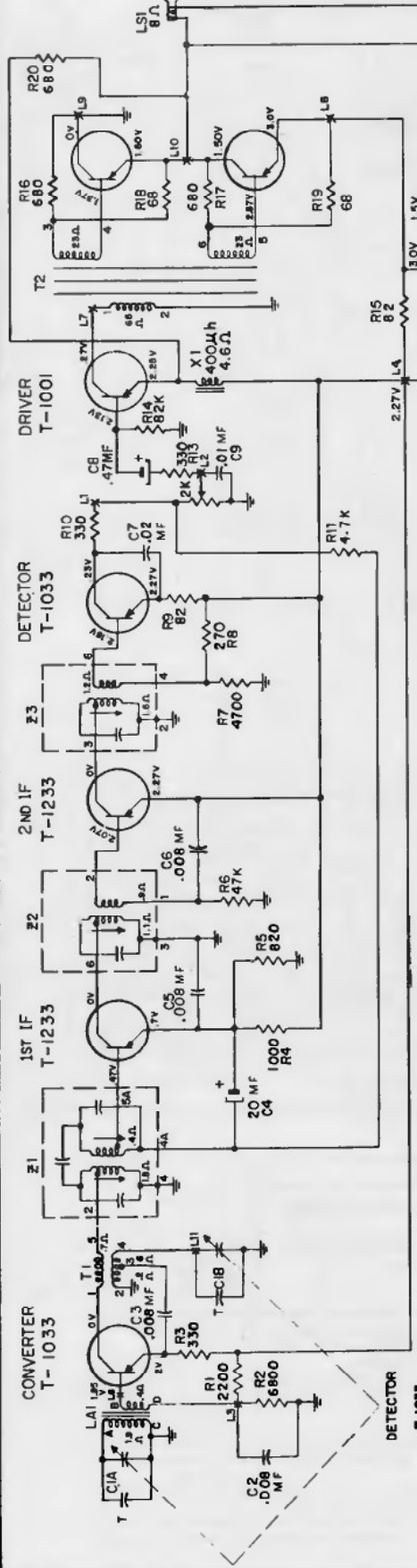

Printed Wiring Panel, Foil Side, Showing Parts Location

PANEL LUG CONNECTION

- L1 Yellow wire from volume control
- L2 Green wire from volume control
- L3 Green wire from LA1 secondary
- L4 Positive lead of C10
- L5 Black lead from C1
- L6 Green lead from LA1 secondary
- L7 Red wire from T2
- L8 Red wire to lug 4 on switch
- L9 Black wire to chassis ground
- L10 Yellow wire to speaker
- L11 Yellow wire to private listening jack
- L12 Black & white wire to C11

FREQUENCY COVERAGE—535 to 1620 KC.
INTERMEDIATE FREQUENCY—455 KC.

SERVICE NOTES

When signal tracing, inject signal at transistor collector and limit input to keep signal across speaker below .6 volts.
Normally, the transistors should be the last item suspected.
If C12 opens serious audio oscillation will result.
Dress of black lead from top, center, frame lug of gang to end ground lug is important to reduce beat. See base layout for lead dress.

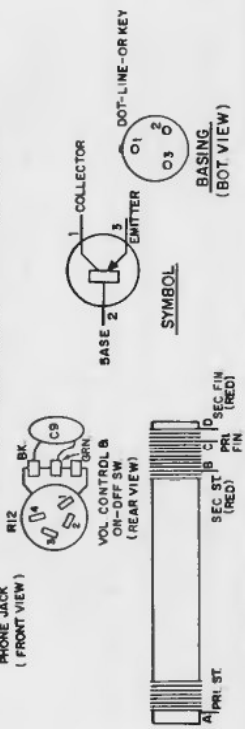

**PHILCO MODELS J-769 J-772 J-773 J-774 J-775
J-838 J-840 J-842 J-845 J-846**

Material applicable to these sets is below and on pages 122 and 123.

MODELS J-769, J-772, J-773, J-774 and J-775 have similar circuitry with slight variations as shown.

MODELS J-838, J-840, J-842, J-845 and J-846 have similar circuitry with slight variations as shown.

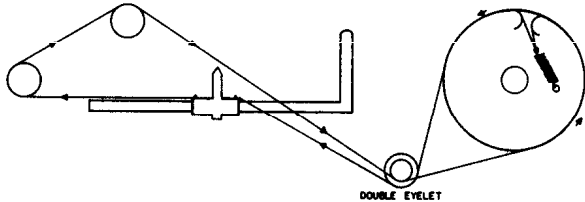

DOUBLE EYELET

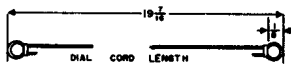

Dial Cord Installation—Model J 774 (Rear View)

SPEAKER PHASING, Models J-845, J-846—When replacing or connecting the two paralleled speakers, it is possible that an out of phase condition may exist; this is readily apparent by weak output and serious distortion. To correct, interchange the leads to one of the speakers.

MODELS J-774 J-775

The push button on top of the cabinet is the Forty Winks alarm control. This feature enables the user to silence the buzzer for 10 minutes. After 10 minutes the buzzer will come on again. The 10 minute cycle may be repeated indefinitely.

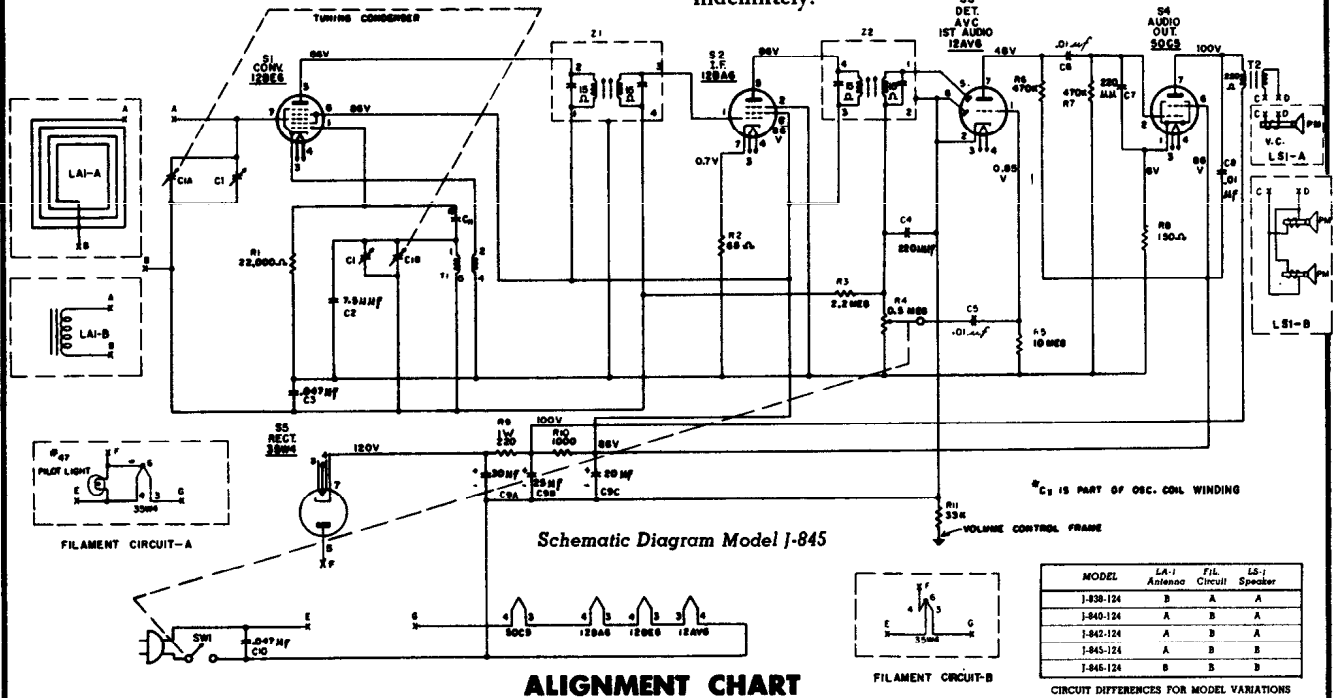

STEP	SIGNAL GENERATOR	RADIO			ADJUST
	CONNECTION TO RADIO	DIAL SETTING	DIAL SETTING	SPECIAL INSTRUCTIONS	
1.	Ground lead to B—; output lead through a .1 mf condenser to grid (pin 7) of 12BE6 or top of r-f tuning condenser.	455 kc.	Tuning gang fully open.	Adjust tuning cores, in order given, for maximum output.	Z2—top Z2—bottom Z1—bottom Z1—top
2.	Radiating loop (See Note below).	1620 kc.	1620 kc.	Adjust for maximum output.	C1-B—osc.
3.	Same as step 2.	1500 kc.	1500 kc.	Adjust for maximum output.	C1-A—aerial

NOTE: Make up a 6-8 turn, 6 inch diameter loop from insulated wire, connect to signal-generator leads, and place near radio loop.

VOLUME R-21, MOST-OFTEN-NEEDED 1961 RADIO SERVICING INFORMATION

PHILCO Models J-769, J-772, J-773, J-774, J-775, J-838, J-840, etc., Continued

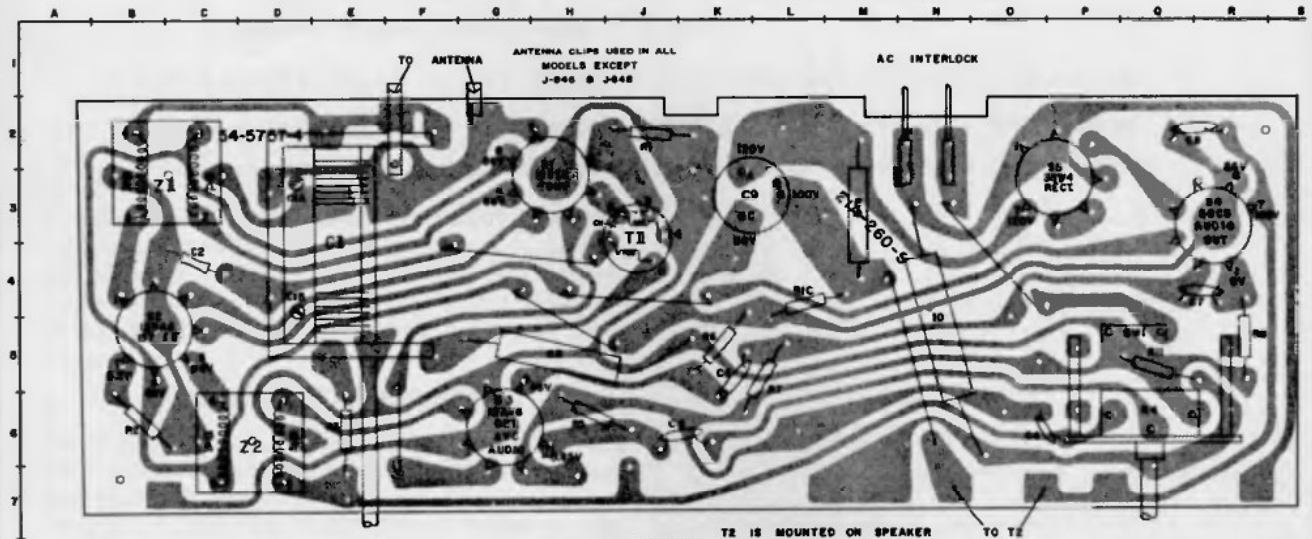

Bottom View of Perma Circuit Panel Component Layout Model J-838

MODEL J-773

In model J-773 the silence time for the forty winks is 7 minutes. After 7 minutes the buzzer goes on again. This 7 minute cycle may be repeated 5 times.

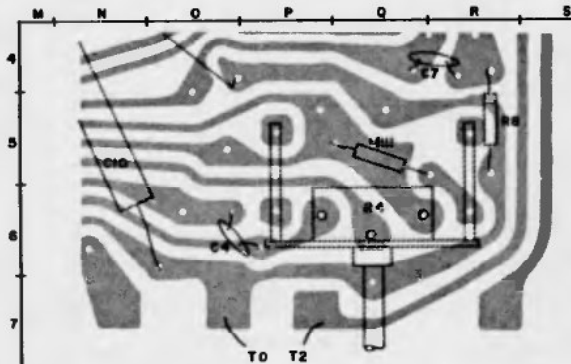

Bottom View, Partial Printed Panel Showing Model J-769 Foil Difference in B-Circuit

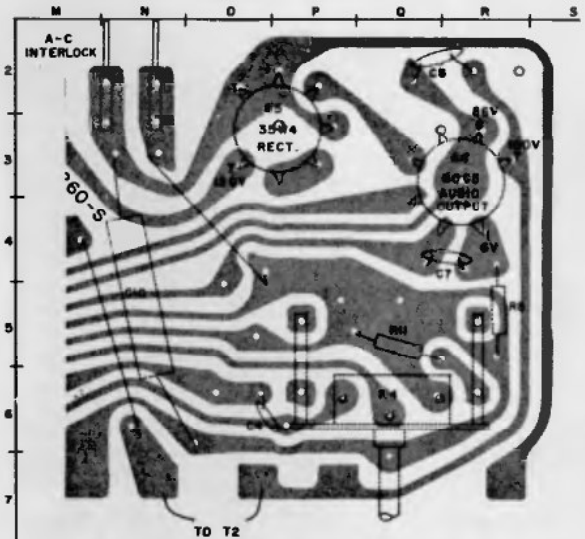

Bottom View, Partial Printed Panel Showing Model J-775 Foil Difference in Rect Fil Circuit and Connections to T2

PARTS COMMON TO ALL MODELS

Sym- bol	Loca- tion	Description	Service Part No.
C1	E3	Capacitor, variable, tuning	
C2	C4	Capacitor, 7.5 mmf, temp. comp.	30-1224-83
C3	H5	Capacitor, .047 mf, AVC	30-4650-45
C4	O6	Capacitor, 220 mmf, diode filter	30-1262-23
C5	J6	Capacitor, .01 mf, 1st audio grid	30-1262
C6	K5	Capacitor, .01 mf, output grid	30-1262
C7	Q4	Capacitor, 220 mmf, output grid	30-1262-23
C8	Q2	Capacitor, .01 mf, output plate	30-1262
C9	L3	Capacitor, electrolytic (3 section) 20 mf, 25 mf, 30mf, +150VDC	30-2585-11
C10	N5	Capacitor, .047 mf line bypass	30-4650-45
R1	J2	Resistor, converter grid, 22,000 ohms	66-3228340
R2	B6	Resistor, I-F bias, 68 ohms	66-0688340
R3	E6	Resistor, AVC filter, 2.2 megohms	66-5228340

Sym- bol	Loca- tion	Description	Service Part No.
R4	Q6	Resistor, volume control, .5 megohms	
R5	H6	Resistor, 1st audio grid, 10 megohms	66-6108340
R6	K5	Resistor, 1st audio plate, 470,000 ohms	66-4478340
R7	L5	Resistor, audio output grid, 470,000 ohms	66-4478340
R8	R5	Resistor, audio output bias, 150 ohms	66-1158340
R9	M3	Resistor, B+ filter, 220 ohms, 1 watt	66-1224340
R10	L4	Resistor, B+ filter, 1000 ohms	66-2108340
R11	Q5	Resistor, isolation, 33,000 ohms	66-3338340
T1	J3	Transformer, osc.	32-4756-1
T2		Part of Speaker	32-8384-2
Z1	C2	Transformer, 1st I-F	32-4583-23
Z2	D6	Transformer, 2nd I-F	32-4583-23
G1		Contact Panel, antenna	28-12282

VOLUME R-21, MOST-OFTEN-NEEDED 1961 RADIO SERVICING INFORMATION

PHILCO Models J-769, J-772 thru J-775, J-838, J-840, J-842, etc., Continued

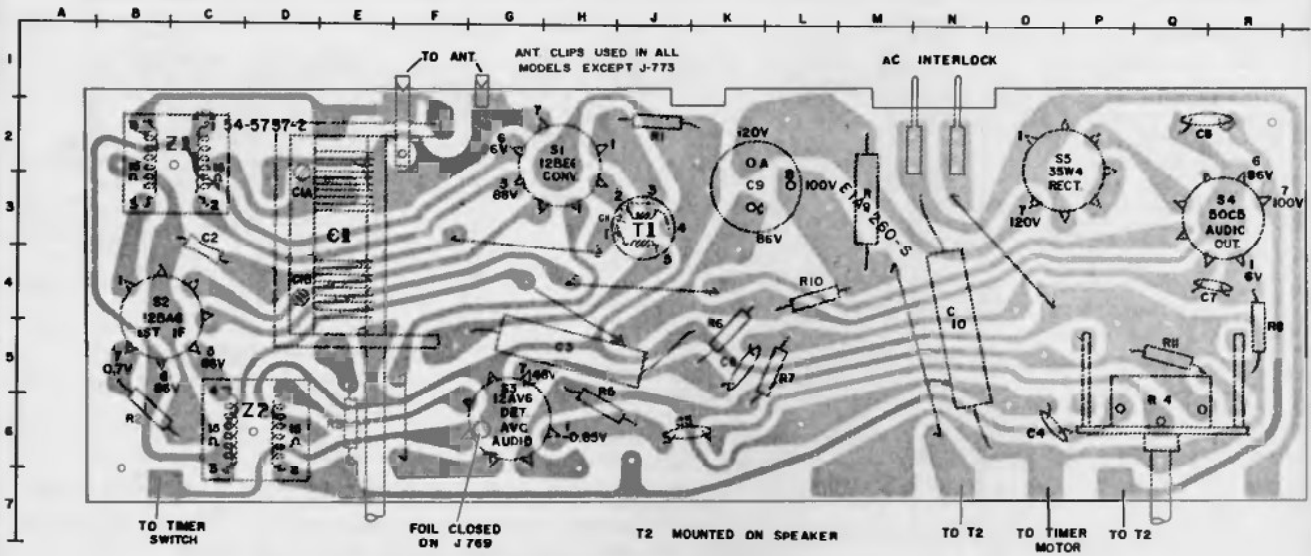

Bottom View of Perma Circuit Panel Component Layout Models 1-772, 1-773, 1-774

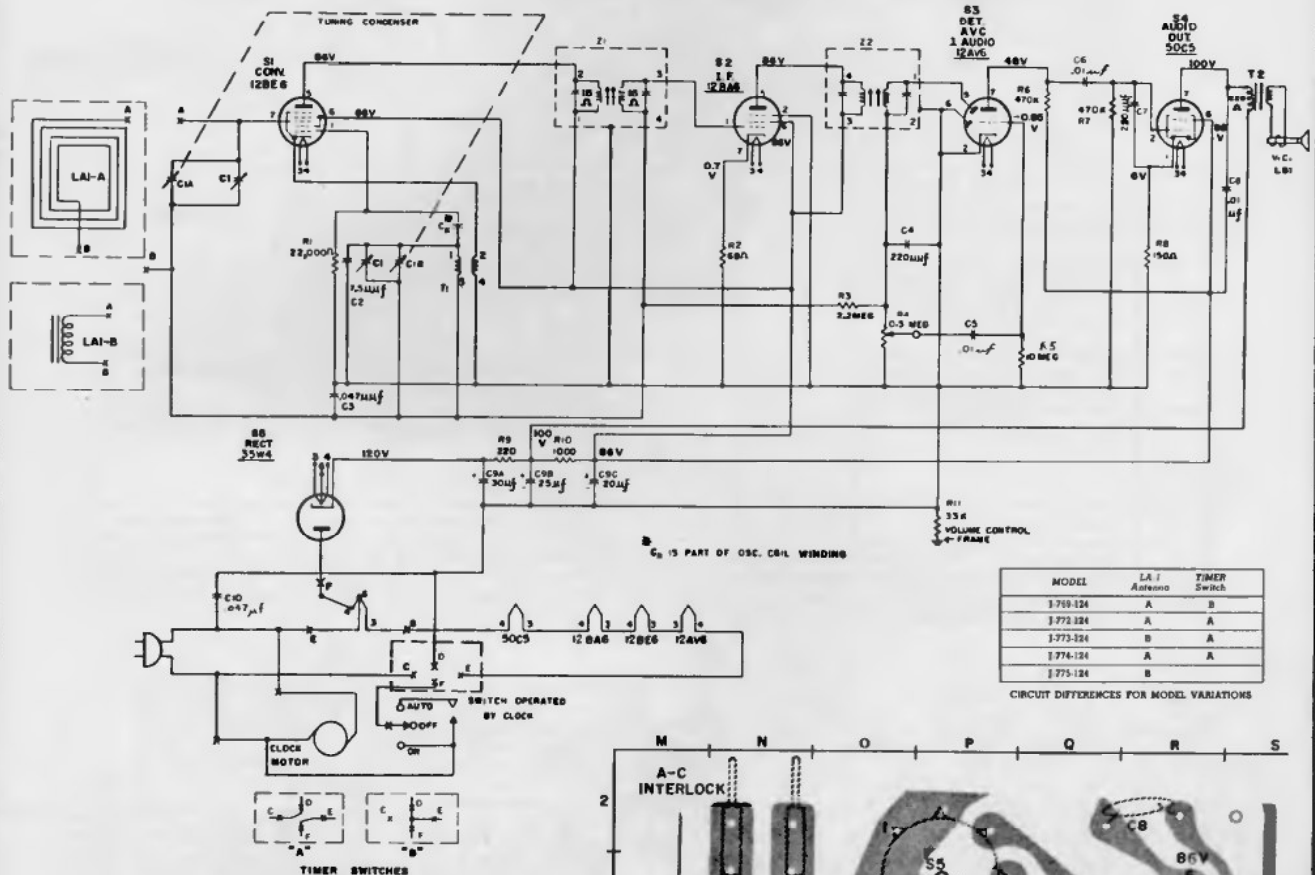

Schematic Diagram Model 1-772

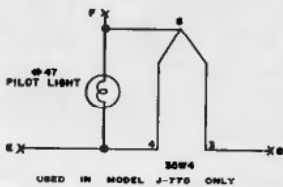

USED IN MODEL J-770 ONLY

MODEL	LA-1 Antenna	TIMER Switch
1-769-124	A	B
1-772-124	A	A
1-773-124	B	A
1-774-124	A	A
1-775-124	B	

CIRCUIT DIFFERENCES FOR MODEL VARIATIONS

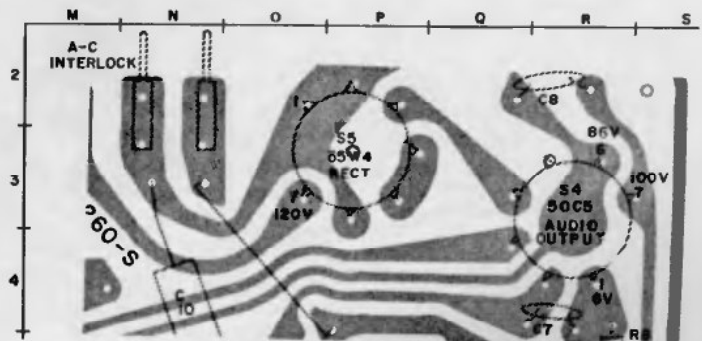

Bottom View, Partial Printed Panel Showing Models 1-840, 1-842, 1-845, 1-846. Foil Difference in Rect. Filament Circuit

PHILCO PORTABLE RADIO TRANSISTOR MODEL T-802, CODE 124

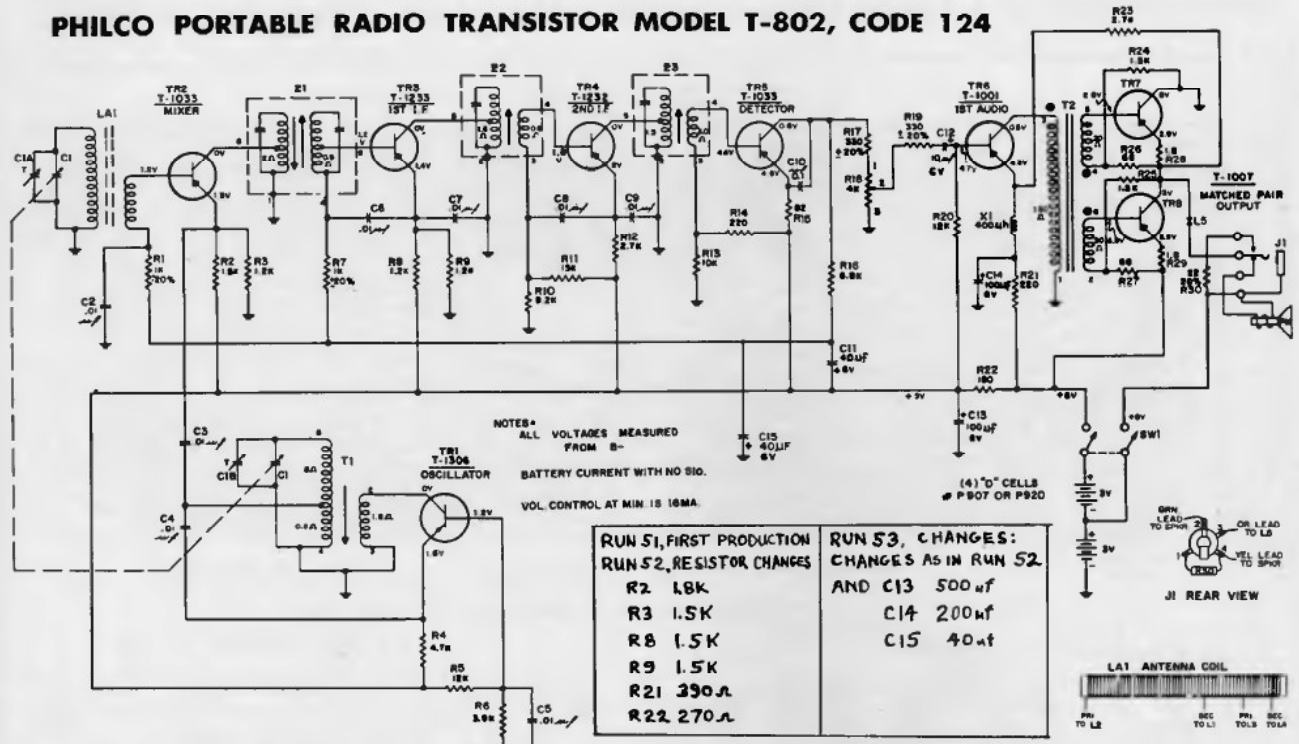

ALIGNMENT CHART

STEP	SIGNAL GENERATOR		RADIO		ADJUST
	CONNECTION TO RADIO	DIAL SETTING	DIAL SETTING	SPECIAL INSTRUCTIONS	
1	Connect signal generator through a .1- μ f. condenser to ant. section of gang.	455 kc.	Tuning gang fully open.	Adjust for maximum output in order given.	Z3—3rd i-f pri. Z2—2nd i-f pri. Z1—bot. core Z1—top core
2	Use radiating loop. (See NOTE 1 below).	600 kc.	600 kc.	Adj. for maximum output. Rock tuning gang while making adj.	T1—osc. core
3	Same as step 2.	1620 kc.	1620 kc. (Tuning gang fully open)	Adjust for maximum output.	C1B—osc. trim.
4	Same as step 2.	1400 kc.	1400 kc.	Adjust for maximum output.	C1A—ant. trim.
5	Repeat steps 2, 3 and 4 until no further improvement is obtained. Always stop on step 4.				

NOTE 1. Use a 6-to-8-turn, 6-inch diameter loop made up of insulated wire. Connect to generator terminals, and place about one foot from radio loop.

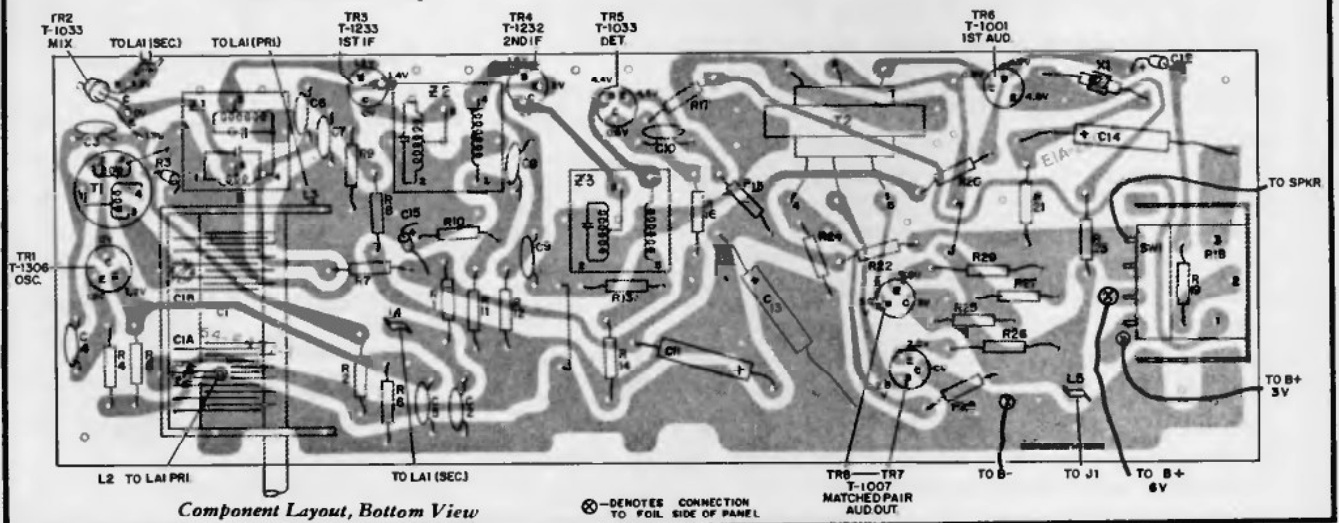

PHILCO PORTABLE RADIO TRANSISTOR MODEL T-901, CODE 124

Reference Symbol	Location	Description	Reference Symbol	Location	Description	Reference Symbol	Location	Description
C1	—	Capacitor, variable, tuning	R6	B1	Resistor, 1.0K Ω , r-f amp. base	R33	J1	Resistor, 22 Ω , jack
C2	A6	Capacitor, .008 mfd, r-f base	R7	B5	Resistor, 47K Ω , mixer base	SW1	R21	Switch
C3	C8	Capacitor, .008 mfd, r-f emitter	R8	B2	Resistor, 39K Ω , mixer base	T1	E8	XFMR, osc.
C4	F7	Capacitor, .008 mfd, osc. emitter	R9	D5	Resistor, 3.3K Ω , mixer emitter	T2	N7	XFMR, aud. out.
C5	F6	Capacitor, .008 mfd, osc. base	R10	A3	Resistor, 1.0K Ω , 1st i-f base	TR1	A7	Transistor, r-f amp., T-1233
C6	B5	Capacitor, .008 mfd, mixer base	R11*	E1	Resistor, 1.2K Ω , 1st i-f emit.	TR2	F7	Transistor, osc., T-1306
C7	D7	Capacitor, .008 mfd, mixer emitter	R12*	E3	Resistor, 1.2K Ω , 1st i-f emit.	TR3	D5	Transistor, mixer, T-1033
C8	E3	Capacitor, .008 mfd, 1st i-f	R13	F5	Resistor, 8.2K Ω , 2nd i-f base	TR4	D1	Transistor, 1st i-f, T-1233
C9	E1	Capacitor, .008 mfd, 1st i-f	R14	F5	Resistor, 15K Ω , 2nd i-f base	TR5	H3	Transistor, 2nd i-f, T-1232
C10	F5	Capacitor, .008 mfd, 2nd i-f	R15	H5	Resistor, 2.7K Ω , 2nd i-f emit.	TR6	H5	Transistor, det., T-1033
C11	H2	Capacitor, .008 mfd, 2nd i-f	R16	M4	Resistor, 10K Ω , 2nd det. base	TR7	L7	Transistor, aud. drive, T-1001
C12	K5	Capacitor, .008 mfd, det. base	R17	M4	Resistor, 220 Ω , 2nd det. base	TR8**	R9	Transistor, aud. out., T-1007
C13	J6	Capacitor, .025 mfd, det. collector	R18	K5	Resistor, 82 Ω , 2nd det. emit.	TR9**	R8	Transistor, aud. out., T-1007
C14	G9	Capacitor, .1 mfd, volume control	R19	J6	Resistor, 6.8K Ω , 2nd det. col.	X1	K7	Choke, 400 μ h
C15	L6	Capacitor, 40 mfd, AVC filter	R20	H7	Resistor, 330 Ω , 2nd det. col.	Z1	B6	Transformer, R-F transistor
C16*	M5	Capacitor, 40 mfd, AVC filter	R21	—	Resistor, 4K Ω , var. vol. control	Z2	B3	Transformer, 1st I-F
C17	L3	Capacitor, 10 mfd, Audio coupling	R22	L9	Resistor, 330 Ω , driver input filter	Z3	E3	Transformer, 2nd I-F
C18A*	N5	Capacitor, 200 mfd, B+ filter	R23*	M6	Resistor, 3.9K Ω , aud. driver base	Z4	J3	Transformer, 3rd I-F
C18B*	N5	Capacitor, 100 mfd, driver emitter	R24*	Q3	Resistor, 120 Ω , B+ filter			
J1	Case	Jack, listening	R25*	Q4	Resistor, 220 Ω , aud. driver emit.			
J1	Case	Antenna coil	R26	Q8	Resistor, 2.7K Ω , aud. feed-back			
LA1	Case	Speaker, 12 Ω V.C., 4 inch	R27	P3	Resistor, 1.5K Ω , aud. collector			
R1	G8	Resistor, 1.5K Ω , r-f amp. emit.	R28	R5	Resistor, 1.5K Ω , aud. output col.			
R2*	C9	Resistor, 1.5K Ω , r-f amp. emit.	R29	Q5	Resistor, 68 Ω , TR8 base			
R3	C8	Resistor, 4.7K Ω , osc. emit.	R30	S3	Resistor, 68 Ω , TR9 base			
R4	H8	Resistor, 12K Ω , osc. base	R31	S6	Resistor, 1.8 Ω , TR8 emitter			
R5	H6	Resistor, 3.9 K Ω , osc. base	R32	R5	Resistor, 1.8 Ω , TR9 emitter			

* RUN 2—CHANGE INFORMATION

C16—deleted
 C18A—400 mfd
 C18B—300 mfd
 R2—1.8K Ω
 R11—1.5K Ω

R12—1.5K Ω
 R23—12K Ω
 R24—270 Ω
 R25—390 Ω

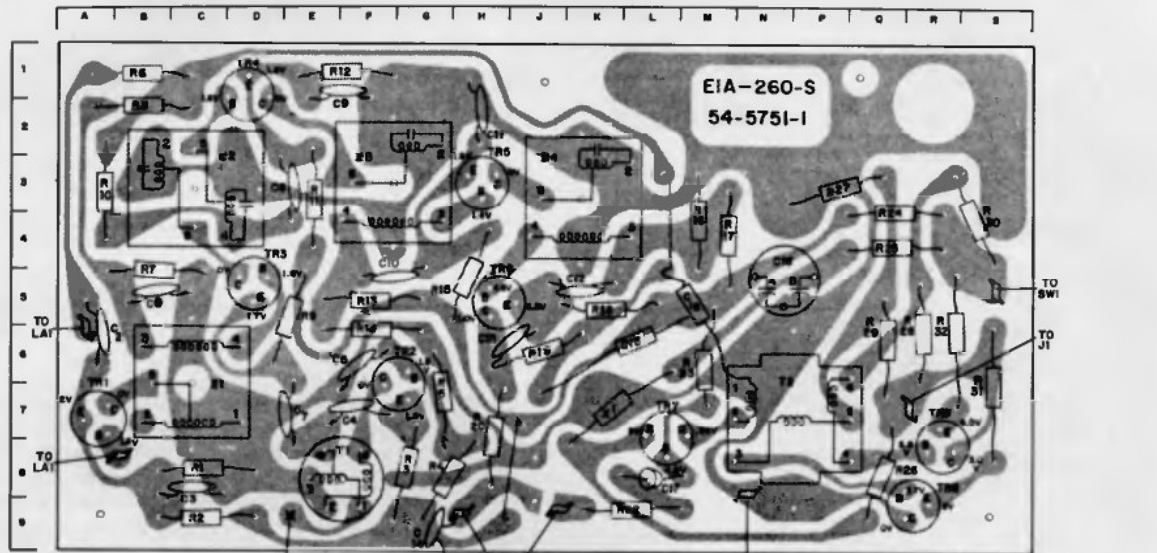
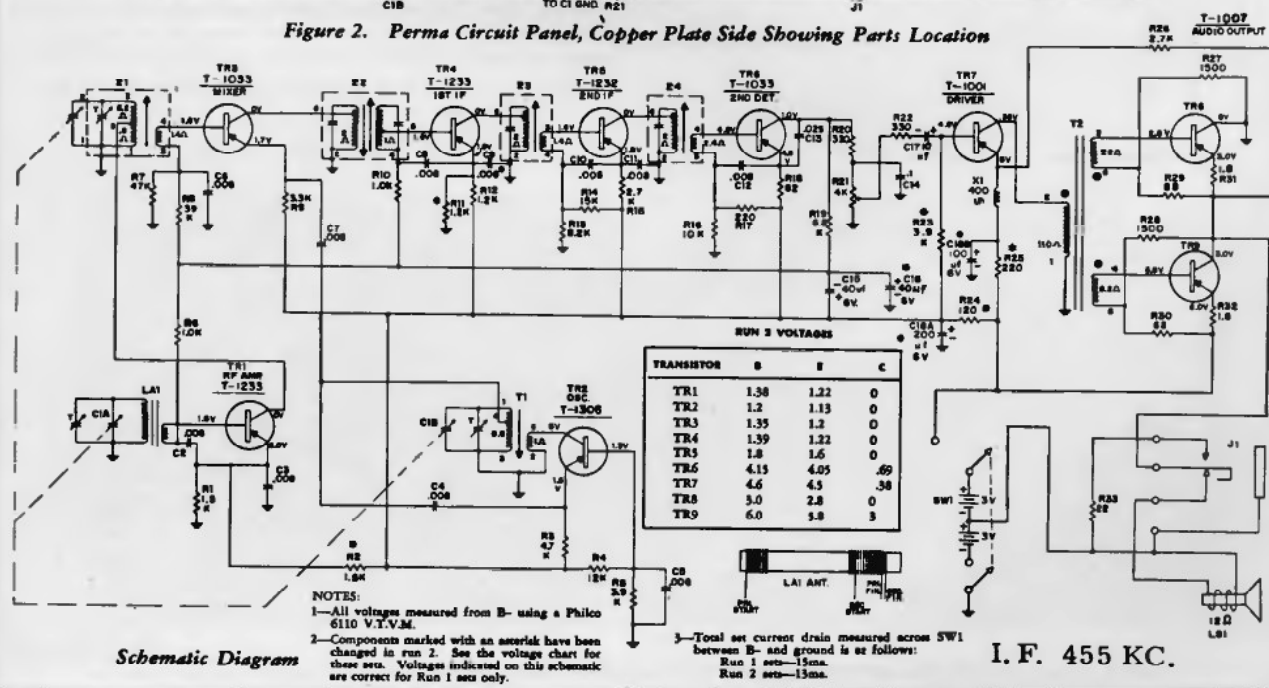
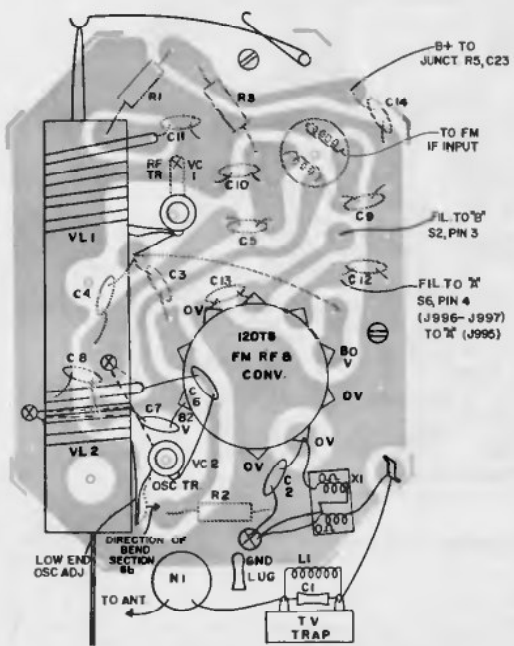
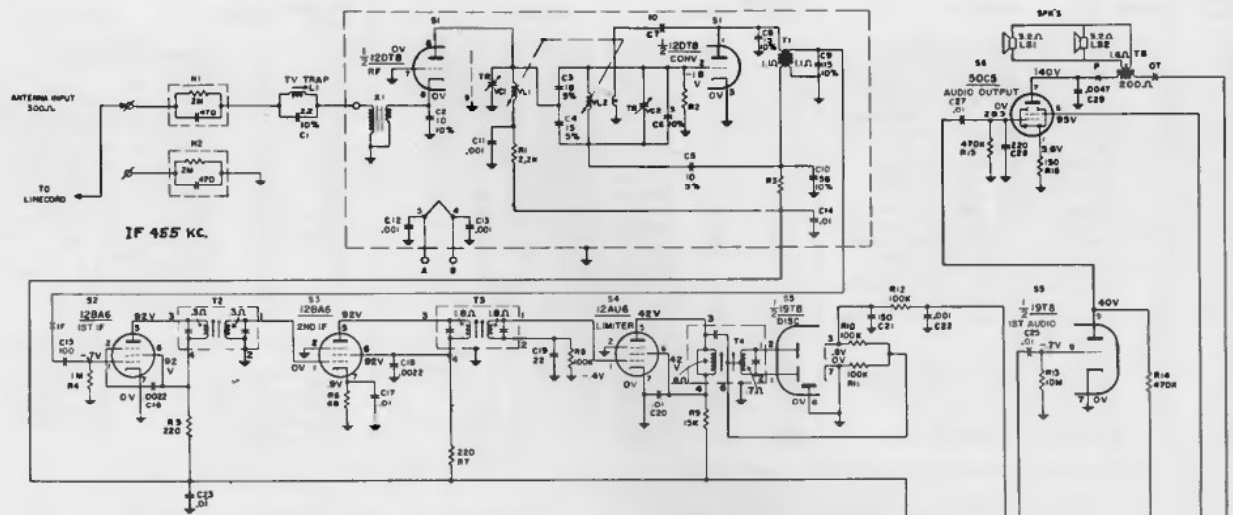

Figure 2. Perma Circuit Panel, Copper Plate Side Showing Parts Location



PHILCO FM MODEL J-995



All Models, Composite View, Foil Side, FM Tuner Panel

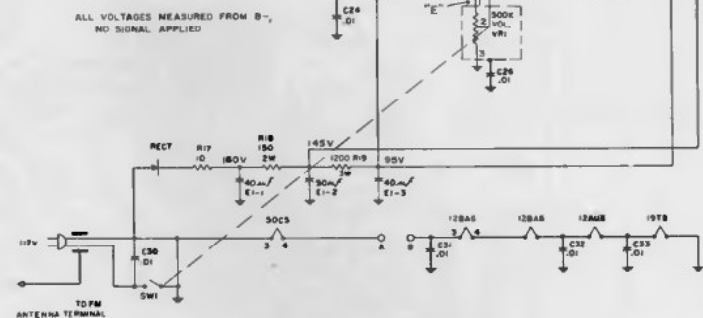

FM tuner disassembly. Remove chassis from cabinet and place foil side up, tuner toward left. To remove bottom shield from tuner remove two screws located at left edge of shield and screw located under left lug of antenna terminal board (remove terminal board mounting screw first). Loosen screw located near antenna terminal board and remaining tuner mounting screw located near left front corner of main panel. Slide shield to left far enough to clear wires and screws. Retighten remaining tuner mounting screws. The perma-circuit wiring panel can now be removed. To do so, remove screw holding TV trap mounting board. Disconnect ground lug from panel and the tuner drive cord from the pulley shaft. Remove screws holding panel in housing. The panel may now be lifted up and out of the tuner housing.

(For dial stringing see page 127)

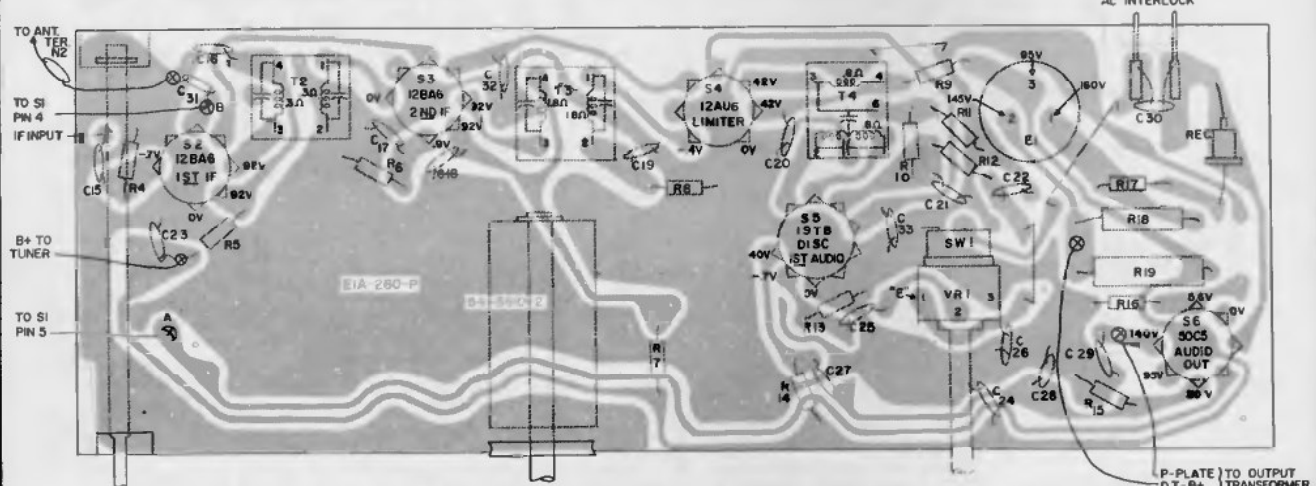

Model J-995, Composite View, Foil Side, Main Panel

PHILCO AM/FM MODELS J-996, J-997

(Also see page 126)

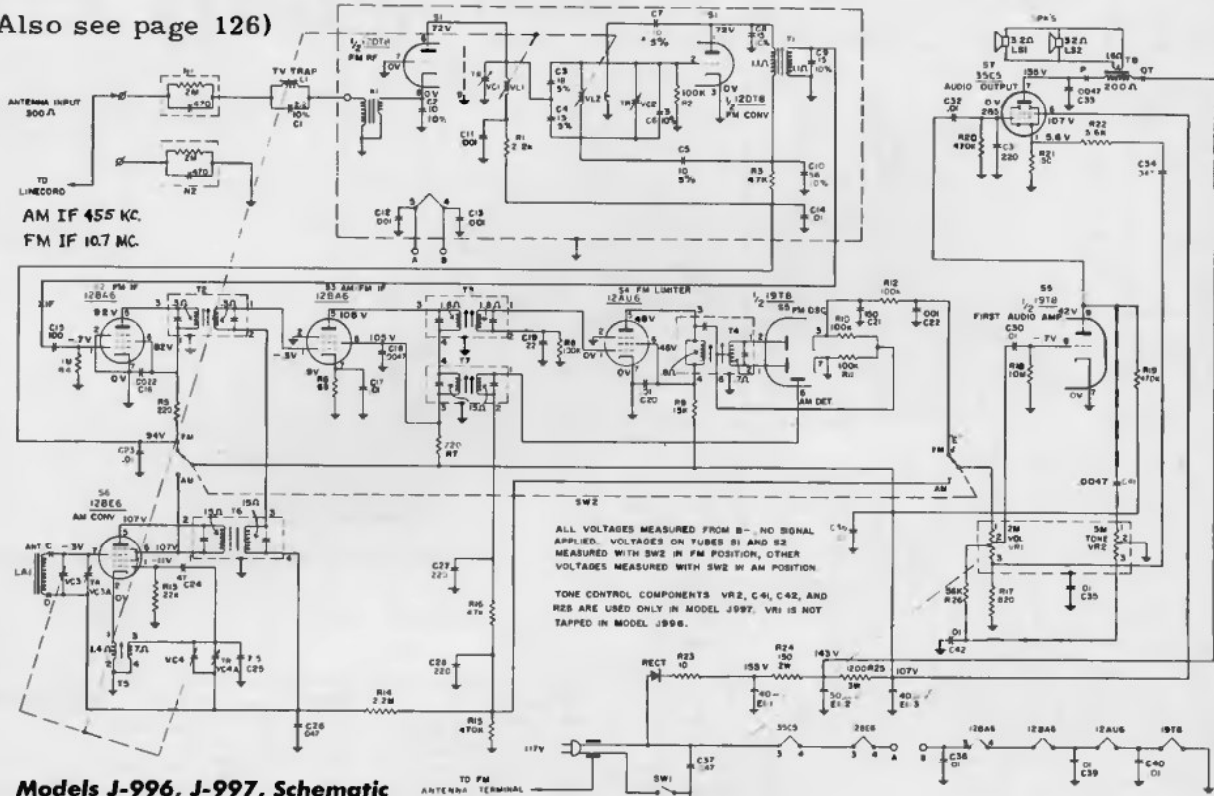

Models J-996, J-997, Schematic

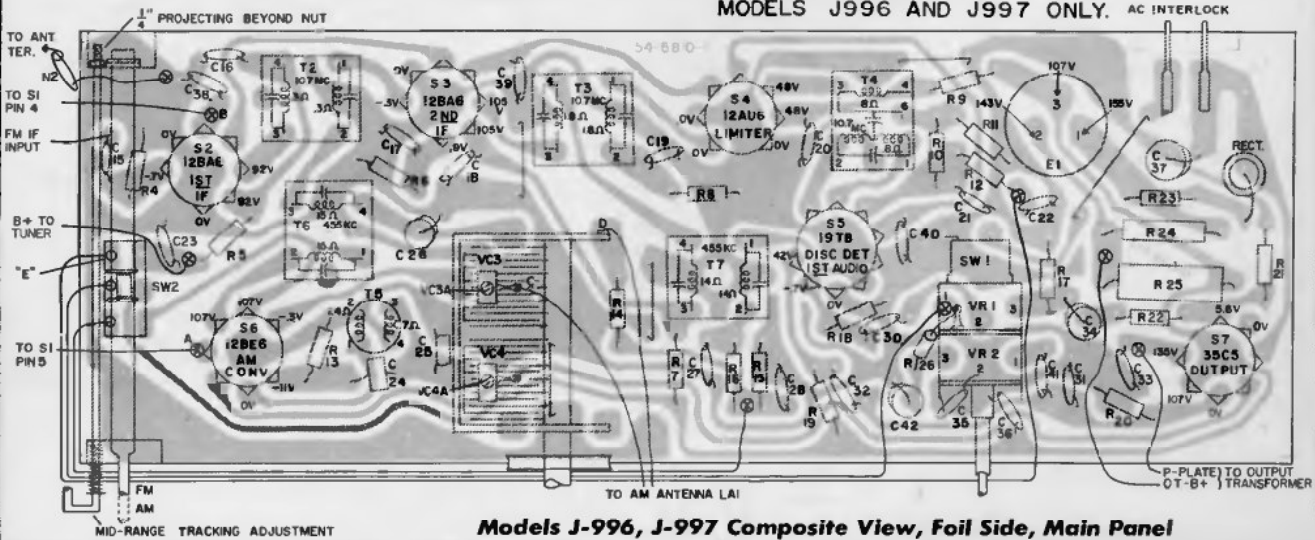
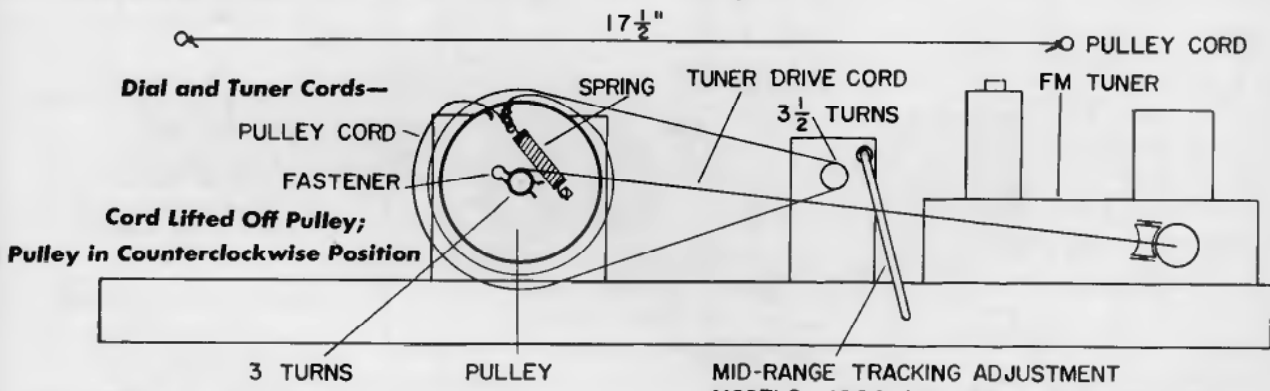

Models J-996, J-997 Composite View, Foil Side, Main Panel

VOLUME R-21, MOST-OFTEN-NEEDED 1961 RADIO

PHILCO MODELS J-1423, J-1425, J-1525, AND J-1626

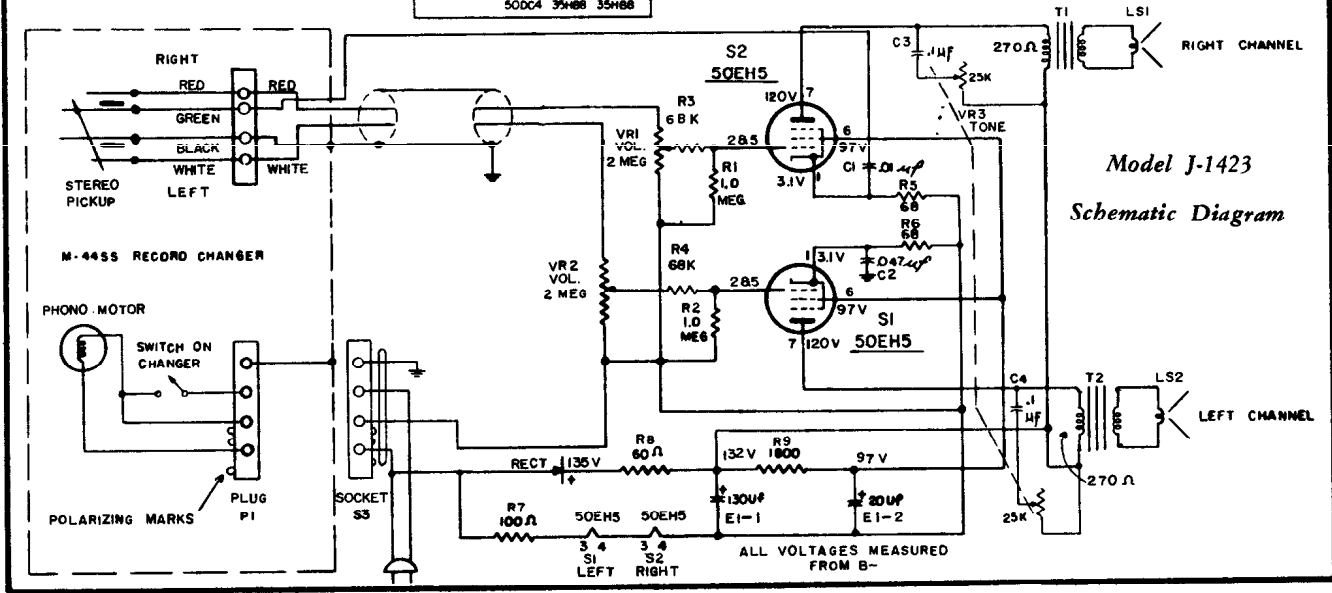
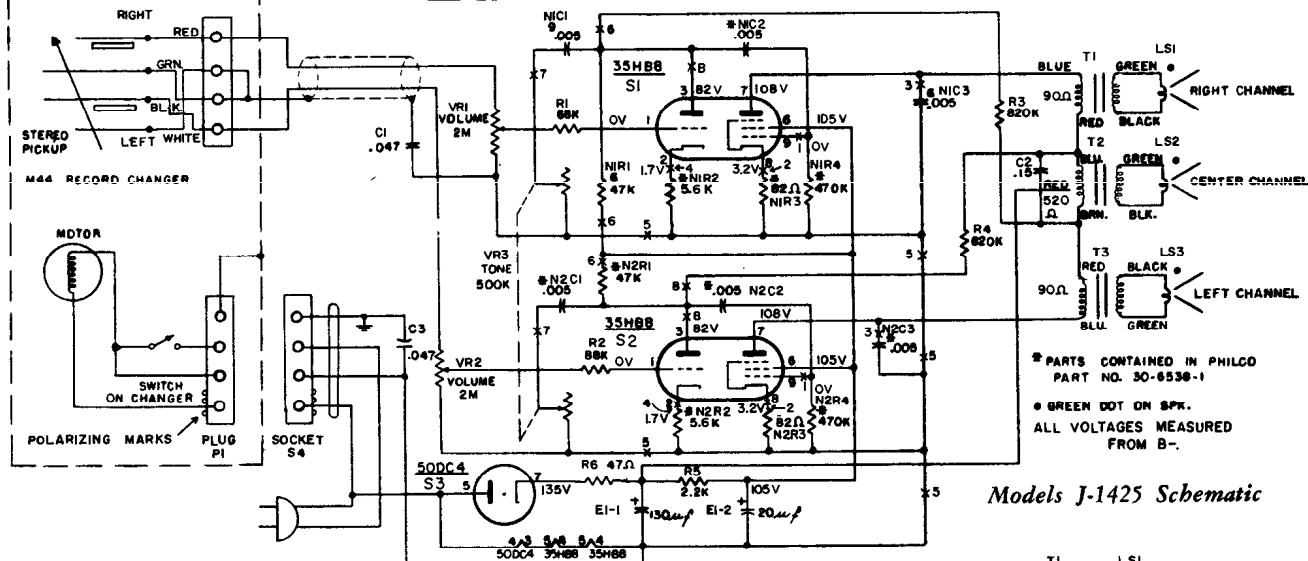
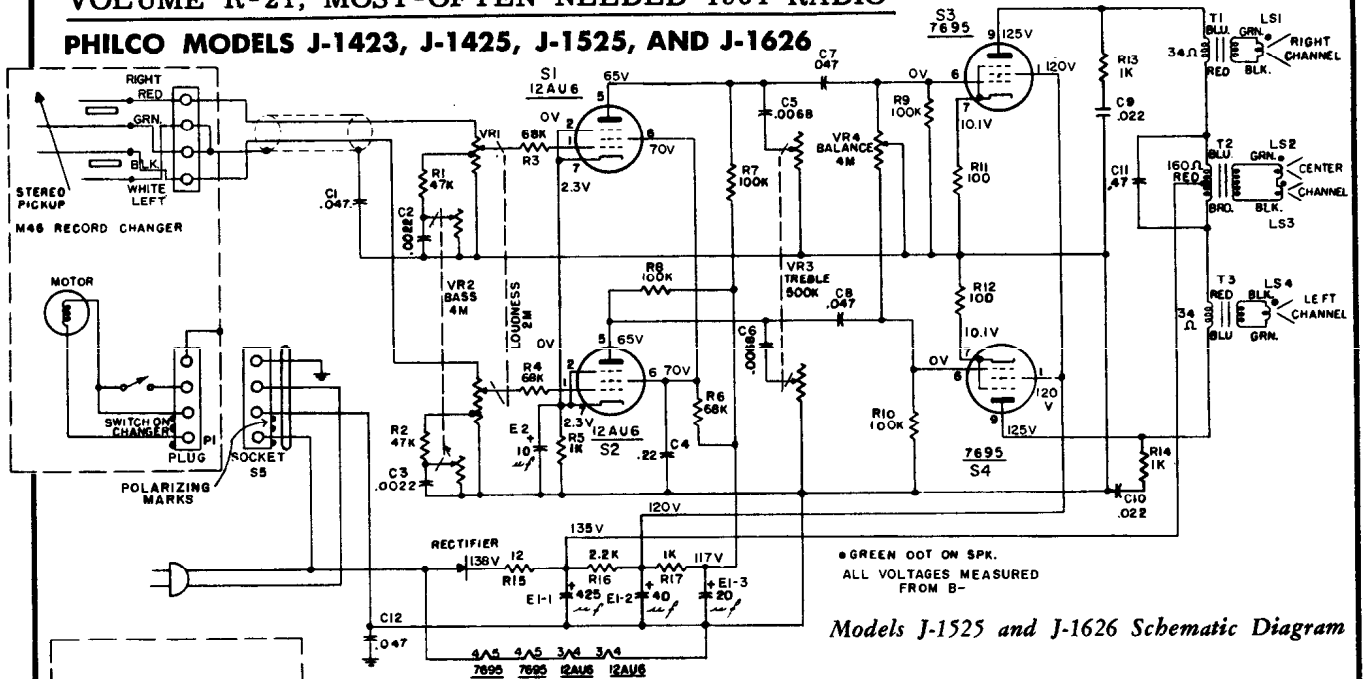

RCA VICTOR MODELS 1-F-1, 1-F-2 SERIES

Chassis No. RC-1201A

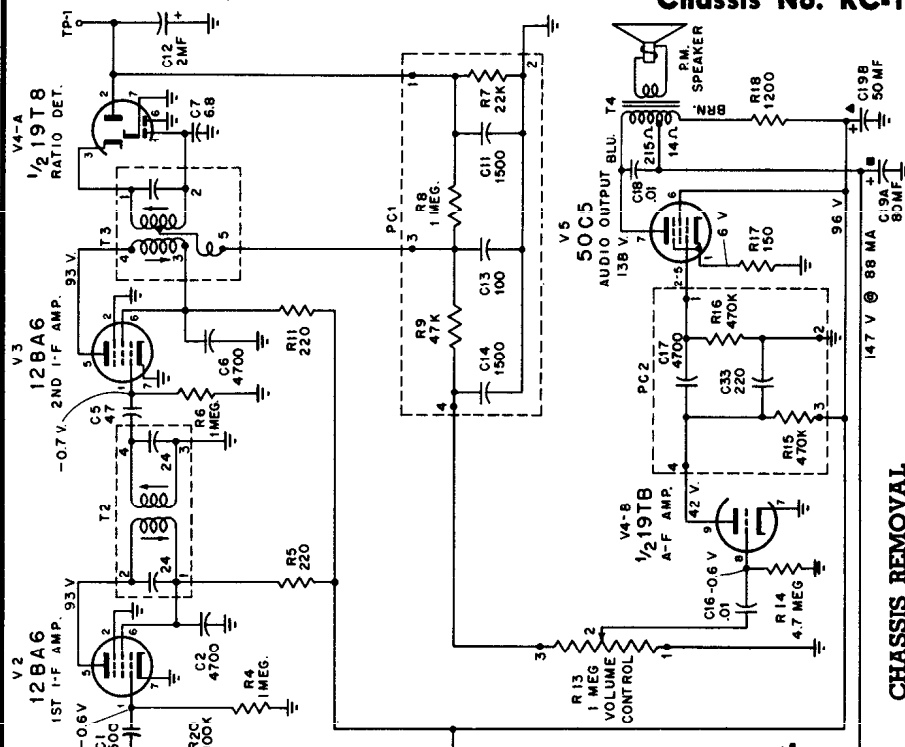

CHASSIS INSTALLATION

From back side of cabinet front—squeeze toward center, two lugs of plastic dial crystal—lay crystal and pointer aside.
Reinstall in reverse order of "Chassis Removal".

RCA Victor
Models 1-F-1, and
1-F-2 Series,
Chassis RC-1201A

CHASSIS REMOVAL

- Remove two screws at bottom rear of cabinet and one screw at top with cabinet back.
- Pull cabinet apart.
- Pull off volume control knob and remove hex nut holding volume control to cabinet front.
- Unhook dial drive cord and remove from drum.
- Bend three retaining lugs to permit removal of power line antenna from cabinet front.
- Remove two screws holding speaker to cabinet front.
- Remove two screws at rear apron of chassis.
- Pull tuning drum shaft out of dial pointer.

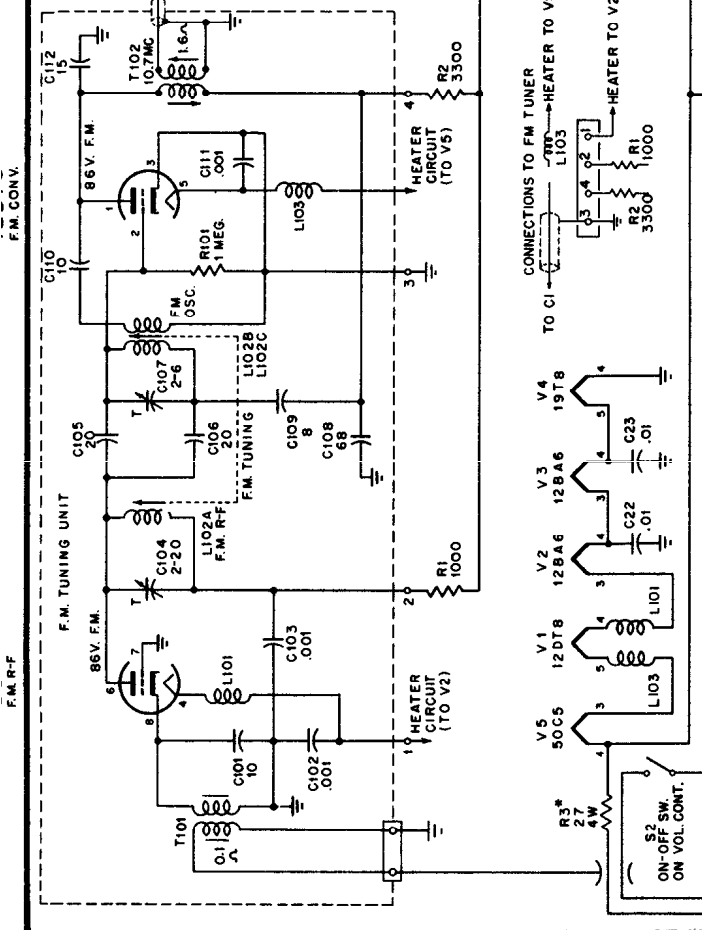

ALL RESISTANCE VALUES IN OHMS. K = 1000
ALL CAPACITANCE VALUES LESS THAN 1.0 IN MF, VALUES ABOVE 1.0 IN MMF EXCEPT AS INDICATED.
VOLTAGES MEASURED TO CHASSIS GROUND WITH "VOLTOHMST" AND SHOULD HOLD WITHIN ±20% WITH 117 V. LINE VOLTAGE. VOLUME CONTROL AT MINIMUM AND NO SIGNAL.
*INDICATES 5% RESISTOR

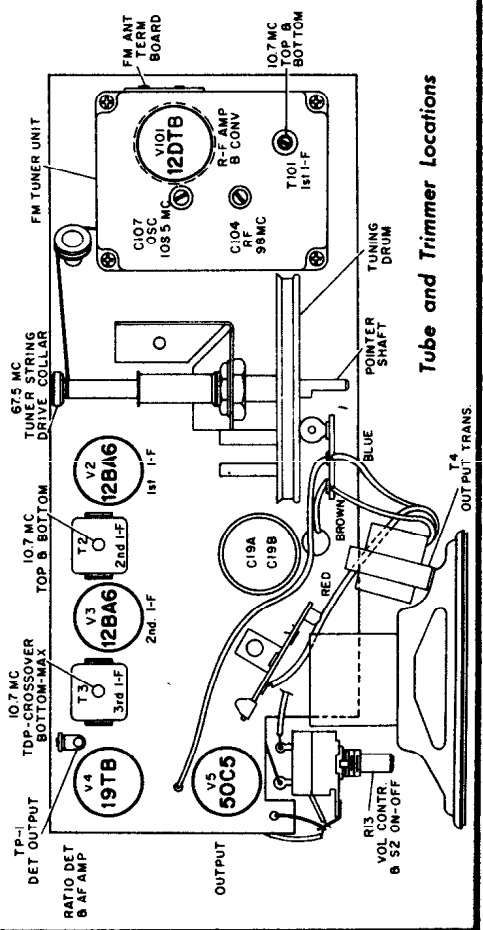

Tube and Trimmer Locations

RCA VICTOR

1-T-1, 1-T-2 Series, and Models 1-T-3, 1-TC-4
Chassis RC-1200 and RC-1200A
(Continued on the next page)

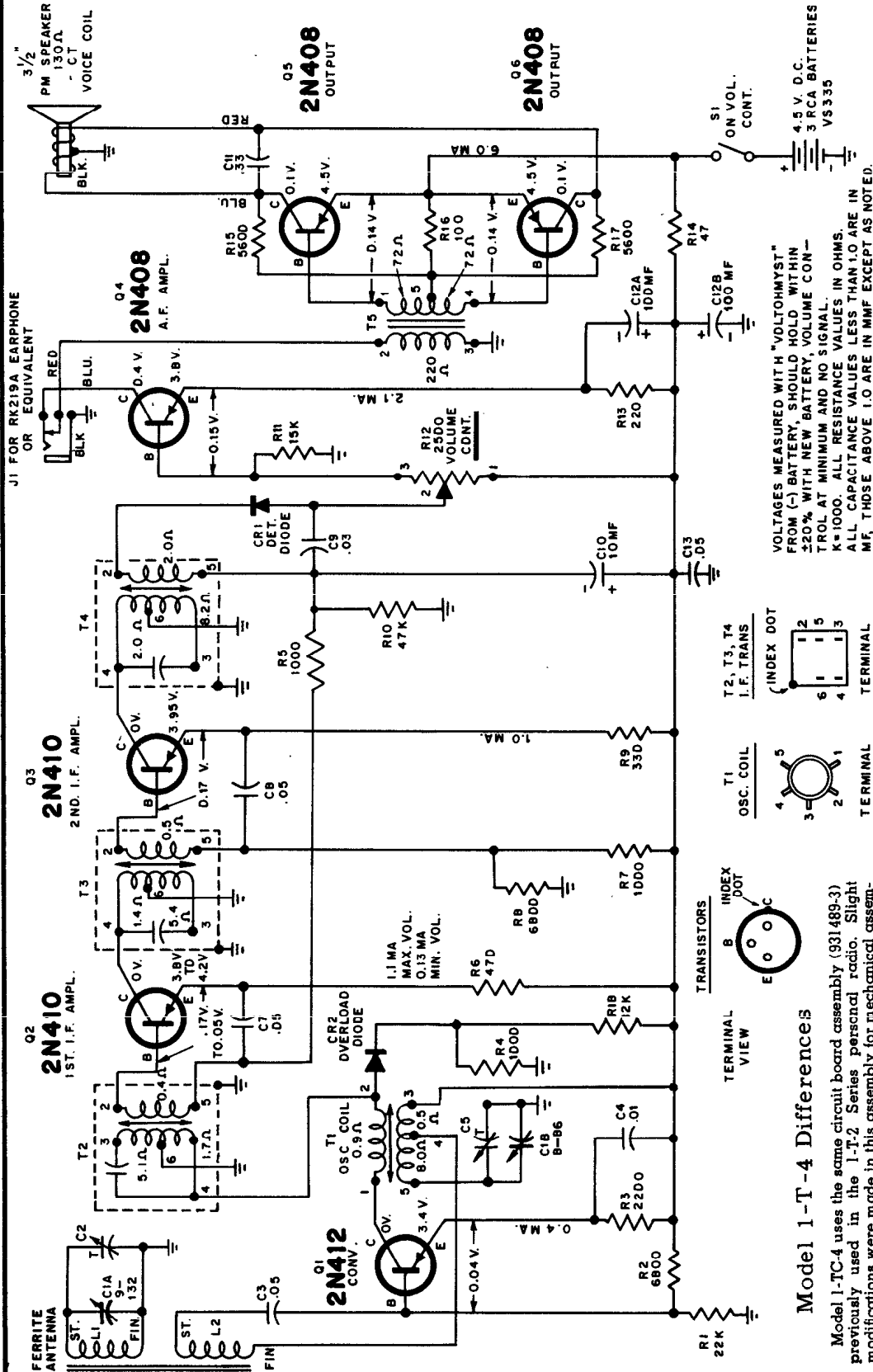

VOLTAGES MEASURED WITH "VOLTOHYST" FROM (-) BATTERY, SHOULD HOLD WITHIN ±20% WITH NEW BATTERY, VOLUME CONTROL AT MINIMUM AND NO SIGNAL. K=1000. ALL RESISTANCE VALUES IN OHMS. ALL CAPACITANCE VALUES LESS THAN 1.0 ARE IN MF, THOSE ABOVE 1.0 ARE IN MMF EXCEPT AS NOTED.

BATTERY CURRENT vs. OUTPUT	
Output Voltage Across Speaker (Blue to Red)	Approximate Battery Current
0	11 ma
1.14 r.m.s. — 3.2 p-p	24 ma
1.8 r.m.s. — 5.0 p-p	32 ma
2.5 r.m.s. — 7.0 p-p	42 ma
3.9 r.m.s. — 10.9 p-p	68 ma

Model 1-T-4 Differences

- Model 1-TC-4 uses the same circuit board assembly (931489-3) previously used in the 1-T-2 Series personal radio. Slight modifications were made in this assembly for mechanical assembly and for clock operation. Major differences are as follows:
1. The battery contacts are attached to the bottom cover and not to the chassis.
 2. There is no earphone jack.
 3. The antenna is mounted on a fiber plate and is parallel to the lengthwise dimension of the chassis.
 4. The switch on the volume control is a double-pole single-throw type and is used to select either RADIO or ALARM mode of operation. At maximum counterclockwise rotation S1A is open and S1B is closed. With the volume control in this position and the radio energized, audio regeneration occurs and a buzzing noise is reproduced by the speaker.

RCA VICTOR

1-T-1 SERIES

(Continued from preceding page)

Chassis No. RC-1200

1-T-2 SERIES, MODEL 1-T-3 1-TC-4

Chassis No. RC-1200A

Circuit Board No. 931489-3

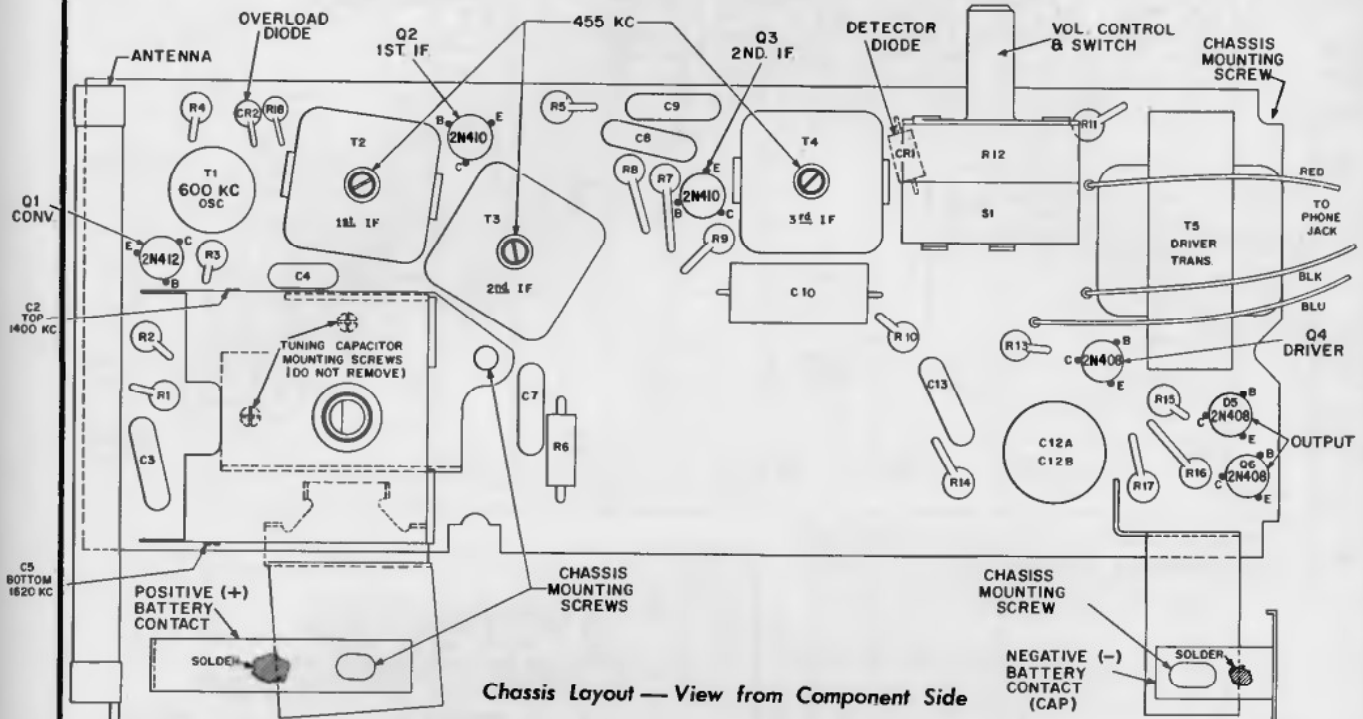

Chassis Layout — View from Component Side

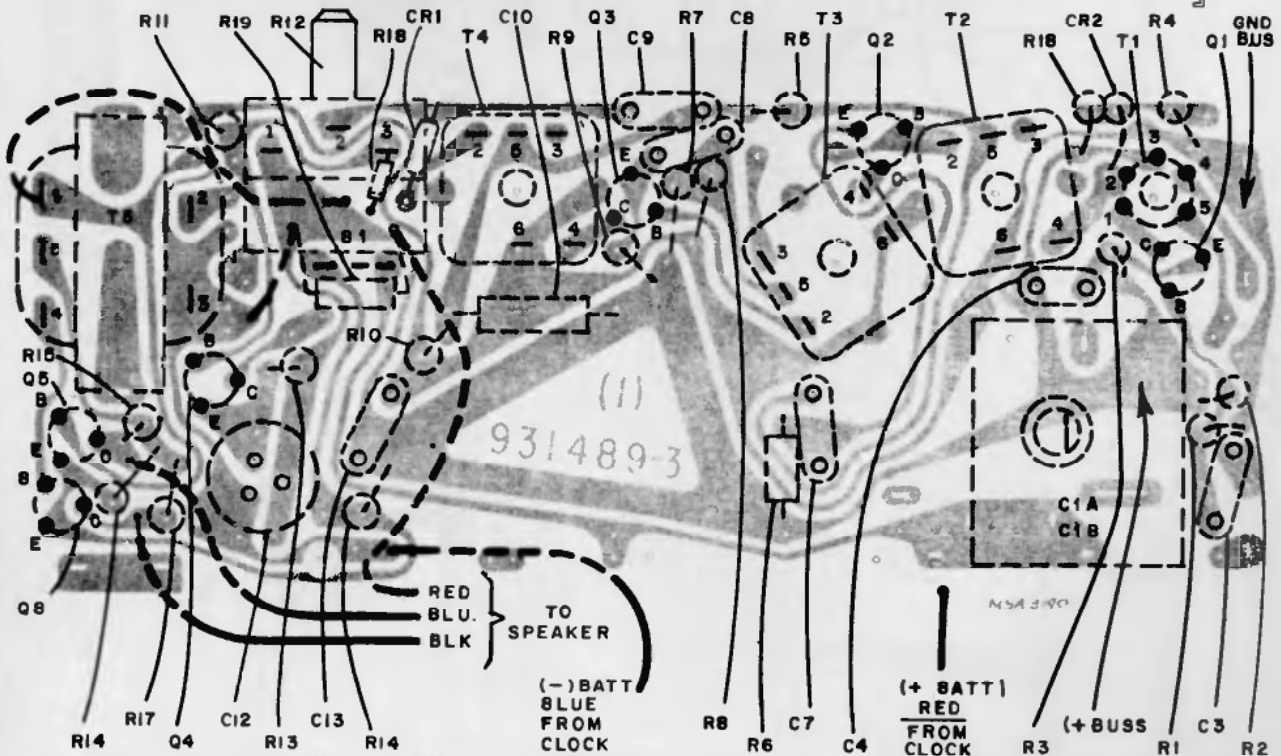

Chassis Wiring and Components — View from Wiring Side

RCA VICTOR

(For later type see next page)

1-TP-1 SERIES, 1-TP-2 SERIES

Chassis No. RC-1199

RC-1199-A

Circuit Board No. 962291-1

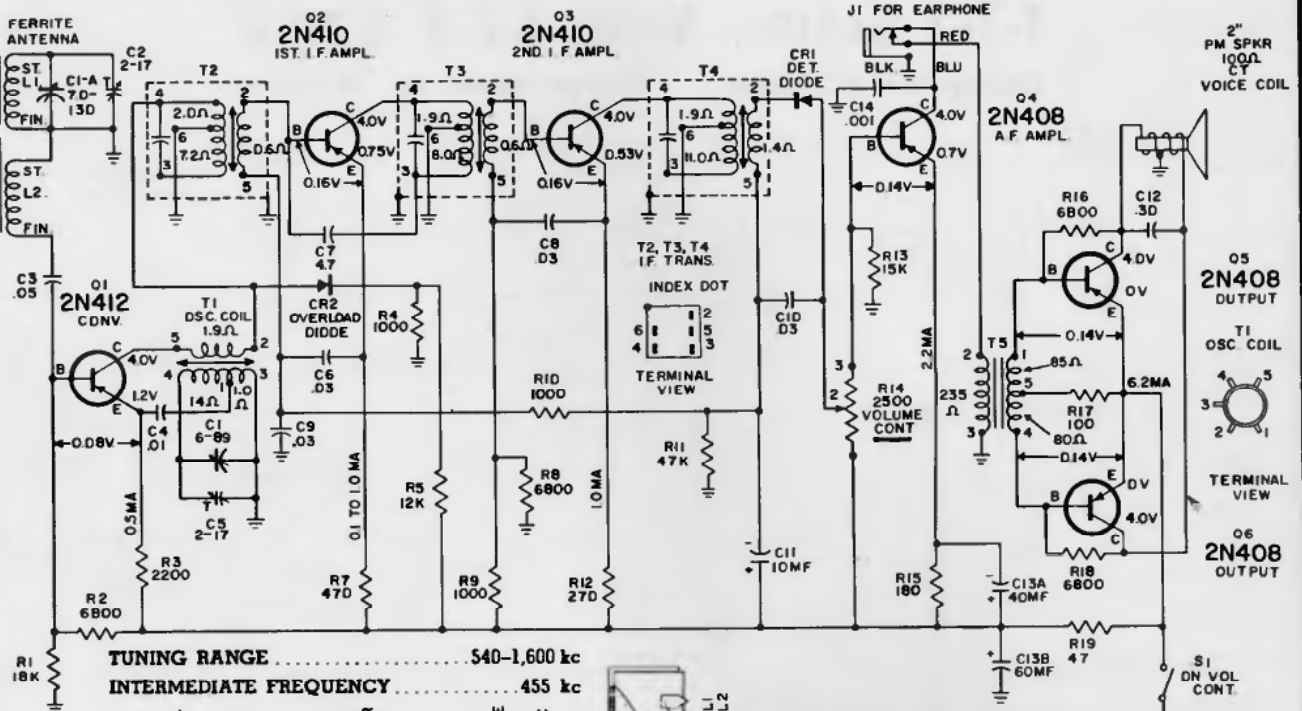

VOLTAGES MEASURED WITH "VOLTOHMYST" FROM (+) BATTERY, SHOULD HOLD WITHIN ±20% WITH NEW BATTERY, VOLUME CONTROL AT MINIMUM AND NO SIGNAL. K-IDDD ALL RESISTANCE VALUES IN OHMS. ALL CAPACITANCE VALUES LESS THAN 10 ARE IN MF, THOSE ABOVE 10 ARE IN MMF EXCEPT AS NOTED.

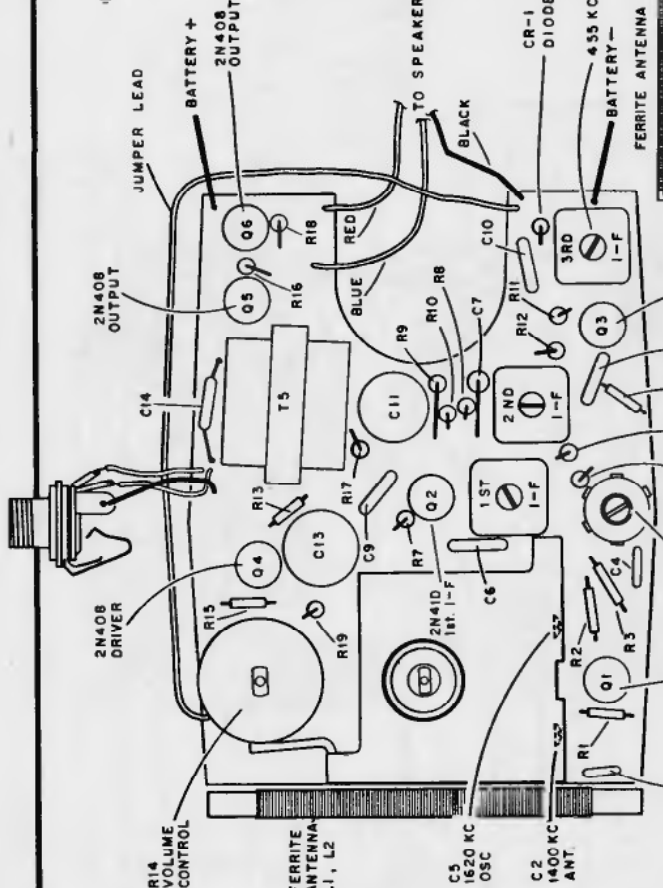

Chassis Layout — View from Component Side

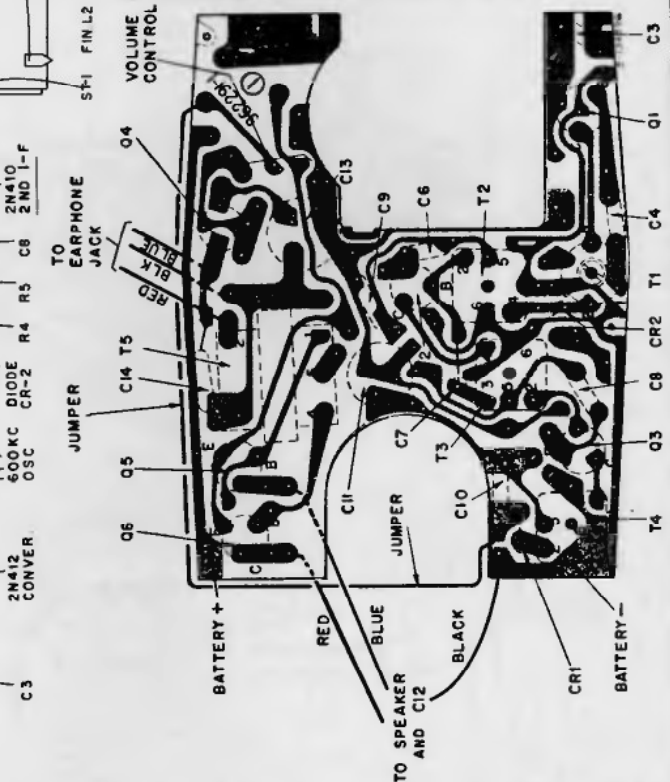

Chassis Wiring and Components — View from Wiring Side

RCA VICTOR 1-TP-1 SERIES

Chassis No. RC-1199B
Circuit Board No. 962537-1

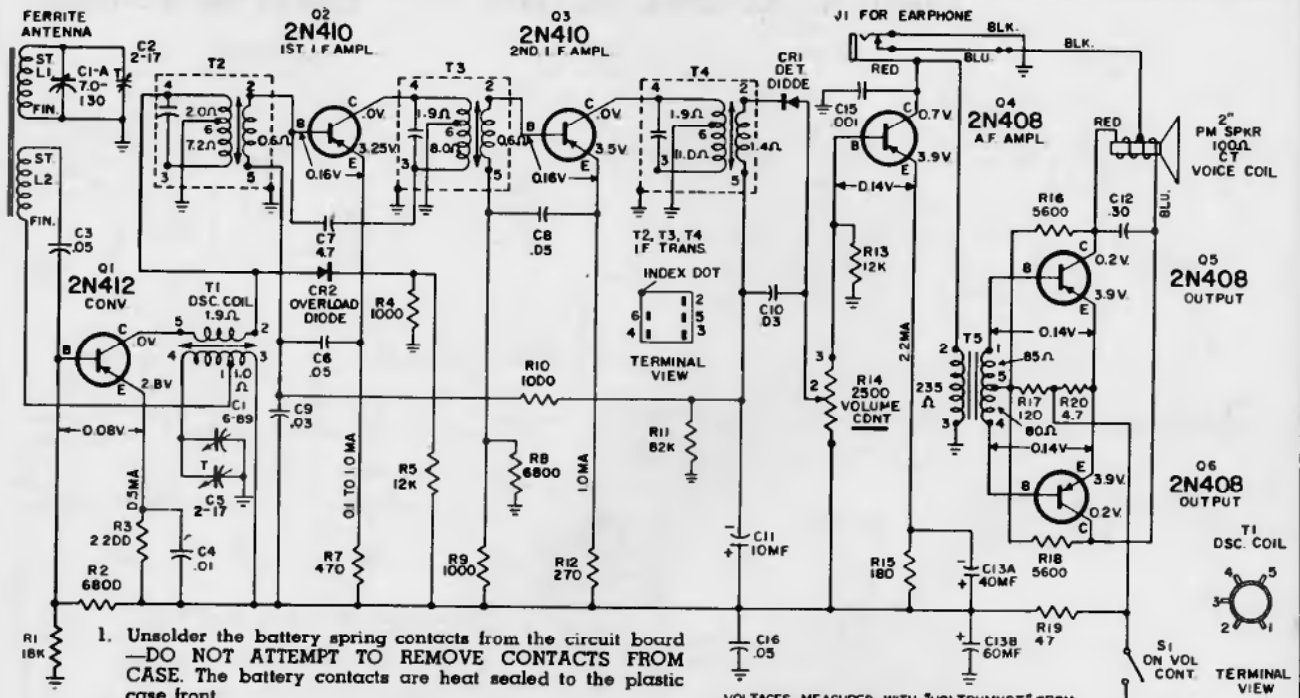

1. Unsolder the battery spring contacts from the circuit board —DO NOT ATTEMPT TO REMOVE CONTACTS FROM CASE. The battery contacts are heat sealed to the plastic case front.
2. Unsolder the three leads from the speaker terminals. The chassis may be serviced without disconnecting it from the speaker.
3. On the 1-TP-1 Series only, pull the dial knob off the tuning condenser shaft.
4. Remove the knurled nut holding the earphone jack to the case.

VOLTAGES MEASURED WITH "VOLTOHMYST" FROM (-) BATTERY (+), SHOULD HOLD WITHIN *20% WITH NEW BATTERY, VOLUME CONTROL AT MINIMUM AND NO SIGNAL. K=1000. ALL RESISTANCE VALUES IN OHMS. ALL CAPACITANCE VALUES LESS THAN 10 ARE IN MF. THOSE ABOVE 10 ARE IN MMF EXCEPT AS NOTED.

5. Remove the two screws holding the circuit board to the case and lift chassis from the case.

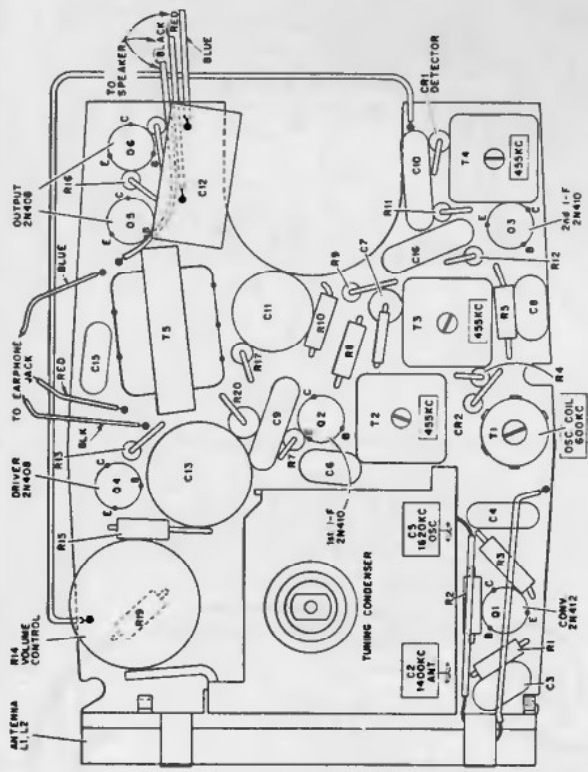

Chassis Layout — View from Component Side

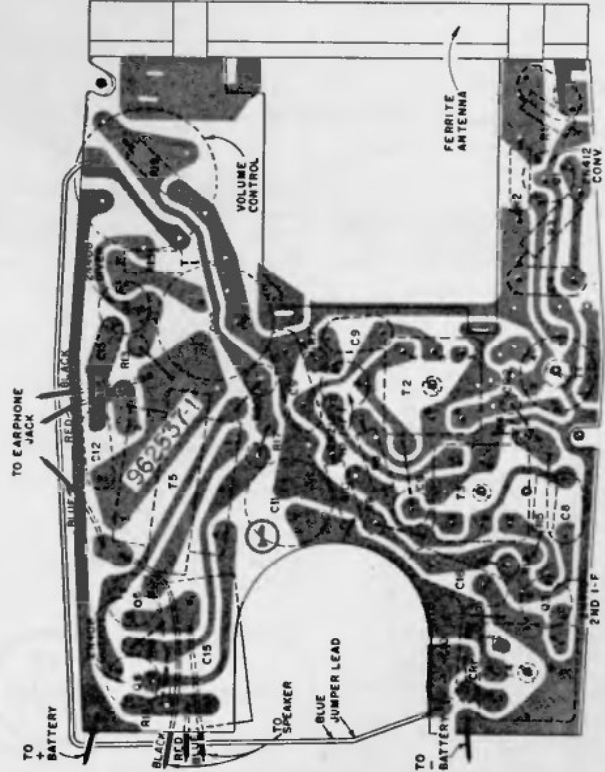

Wiring and Components — View from Wiring Side

The assembly represented above is viewed from the wiring side of the board. The printed wiring, on the rear side of the board, is presented in "phantom" view superimposed on the component layout of the reverse side.

RCA

1-X-2 SERIES, 1-X-3 SERIES

Chassis No. RC-1202A, RC-1202B

1-X-4 SERIES

Chassis No. RC-1202C

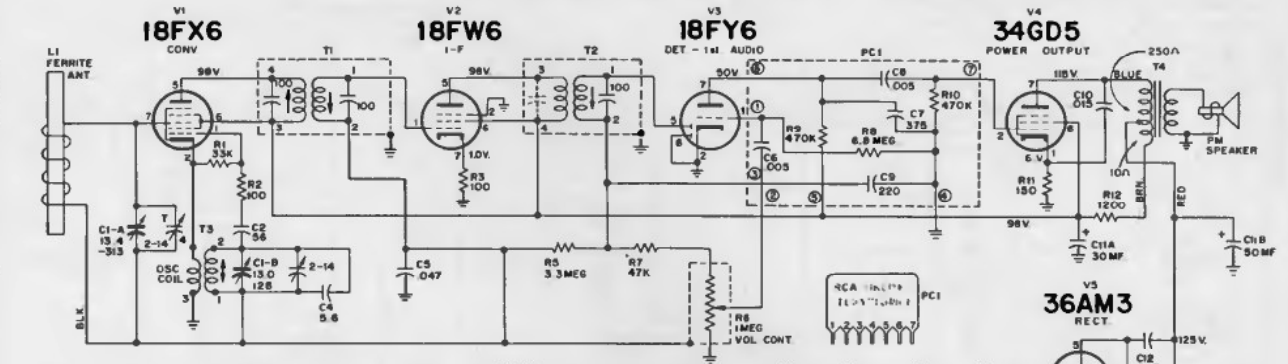

RC-1202 B
1-X-3 SERIES

K-1000
ALL RESISTANCE VALUES IN OHMS. ALL CAPACITANCE VALUES LESS THAN 1.0 IN MF. VALUES ABOVE 1.0 IN MMF. UNLESS OTHERWISE INDICATED.

VOLTAGES MEASURED TO COMMON NEGATIVE (+) WITH "VOLTOHMIST" AND SHOULD HOLD WITHIN ±20% WITH 117 VOLT INPUT.

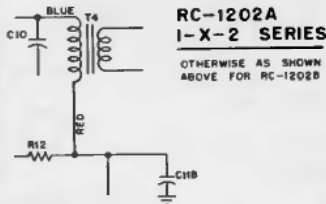

RC-1202A
1-X-2 SERIES
OTHERWISE AS SHOWN ABOVE FOR RC-1202B

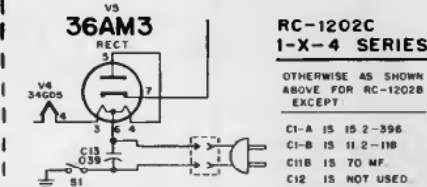

RC-1202C
1-X-4 SERIES
OTHERWISE AS SHOWN ABOVE FOR RC-1202B EXCEPT:
C1-A IS 15 2-396
C1-B IS 11 2-118
C11B IS 70 MF.
C12 IS NOT USED.

* C12 USED IN 1-X-2 & 1-X-3
C13 USED IN 1-X-4
TWO POSITIONS SHOWN FOR R12

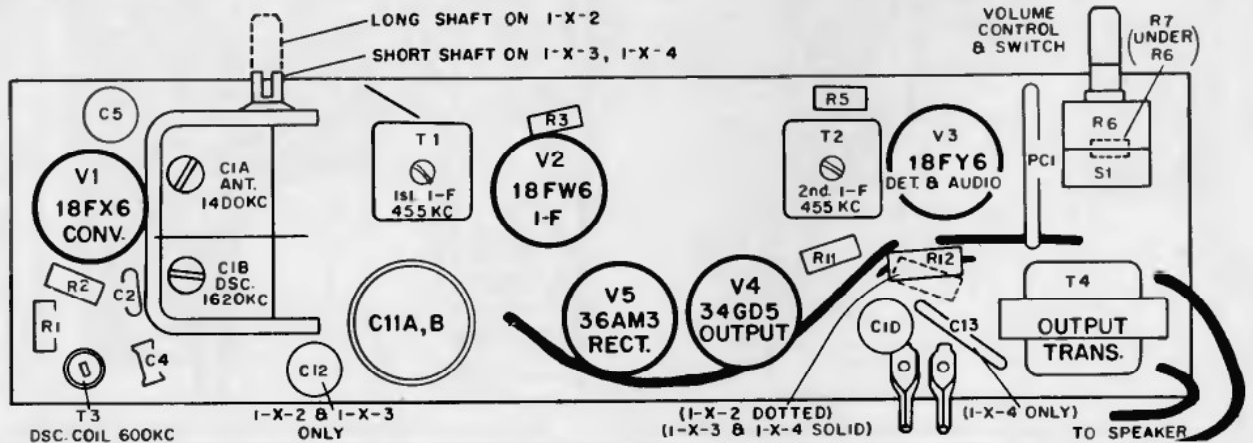
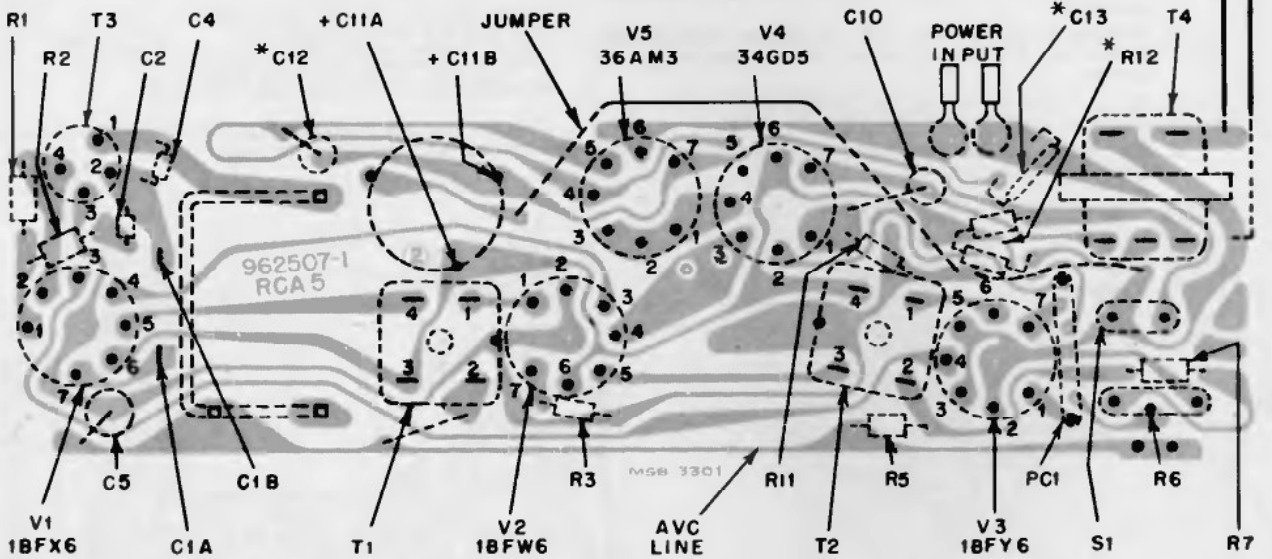

RCA VICTOR

VP-34 SERIES

Chassis No. RS-34P

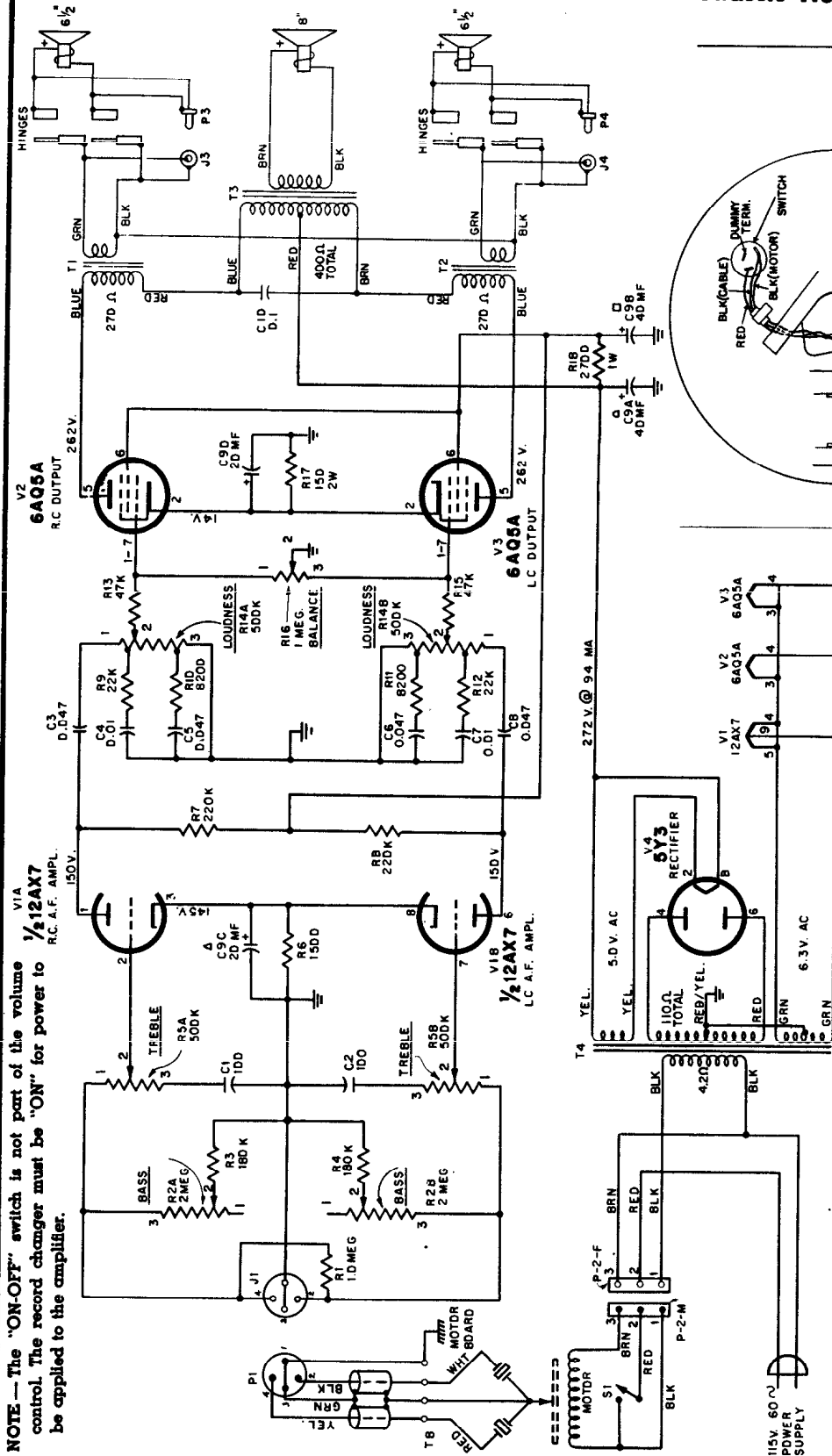

NOTE — The "ON-OFF" switch is not part of the volume control. The record changer must be "ON" for power to be applied to the amplifier.

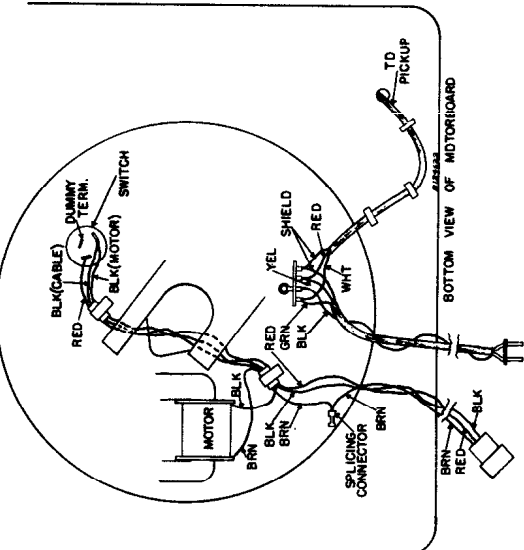

Record Changer Wiring

VOLTAGES MEASURED TO CHASSIS GROUND WITH "VOLTOMYST" SHOULD HOLD WITHIN $\pm 20\%$ WITH 115 V. LINE. VOLUME CONTROL AT MINIMUM NO SIGNAL.

K=1000
ALL RESISTANCE VALUES IN OHMS.
ALL CAPACITANCE VALUES LESS THAN 1.0 IN MMF, VALUES ABOVE 1.0 IN MMF, EXCEPT AS INDICATED.

Model VP-34 is a portable stereo-orthophonic, hi-fidelity "Victrola." It is a complete multi-channel record playing system consisting of a record changer, an amplifier, and three speakers housed in a 3-piece luggage-type cabinet. The record changer, amplifier, and 8" PM "woofer" speaker are contained in the main unit. A 6 1/2" PM "Duo-cone" speaker and its 10' interconnecting cable, are contained in each of the hinged, swing-out side units.

When carrying, the side units are closed across the front of the main unit and latched to it. When operating, the side units are swung out, one to each side of the main unit; in this position the hinges function as the speaker connectors. Should greater stereophonic effect be desired, the side units may be lifted off the main unit (split hinges) and placed equidistant from it at each side. When thus used, the interconnecting cables of the side units are plugged into the appropriate jacks

RCA VICTOR VP-33 SERIES VC-270 SERIES

Models VC-271, VC-272, VC-274
Chassis No. RS-188

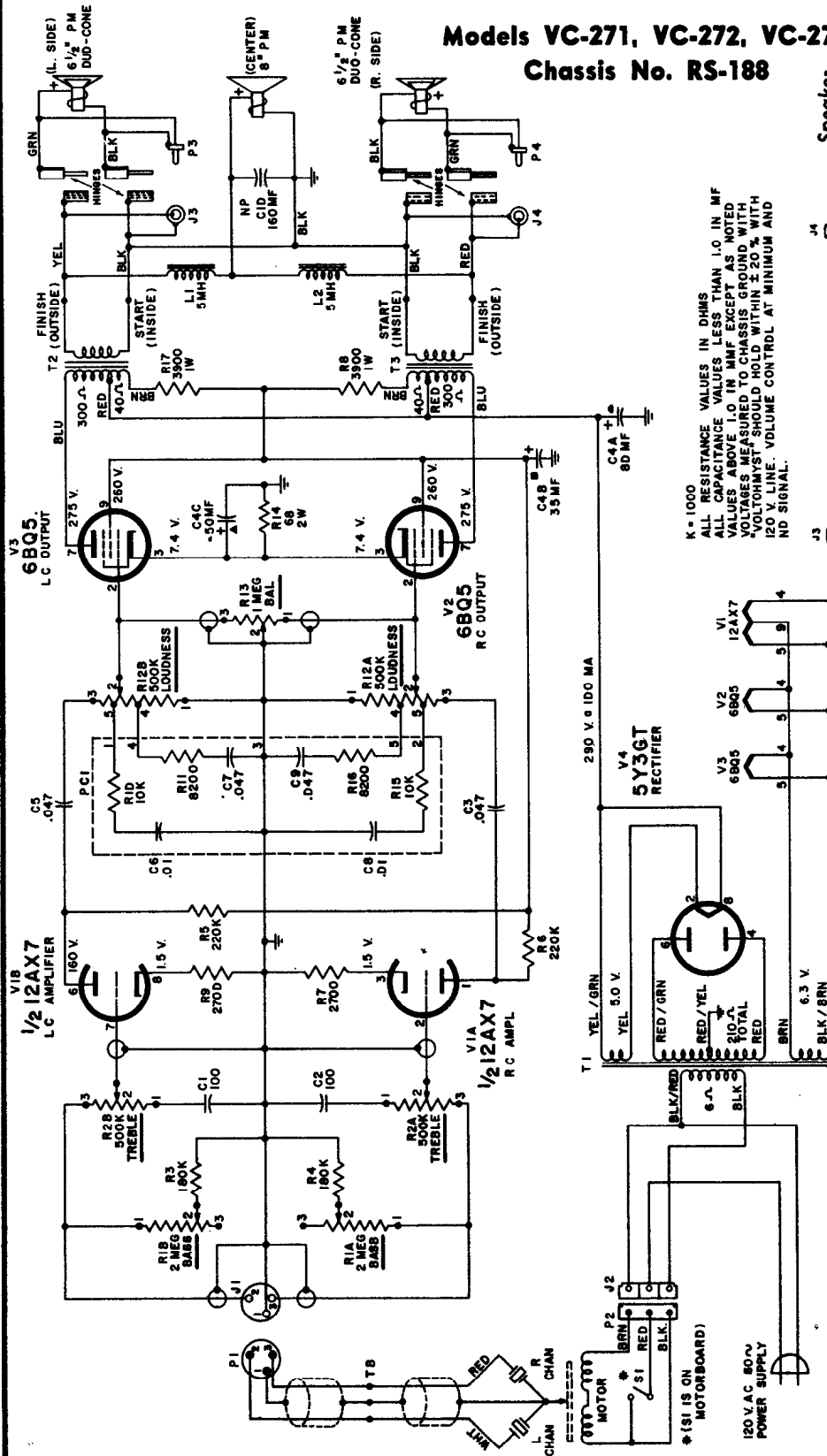

K = 1000
ALL RESISTANCE VALUES IN OHMS
ALL CAPACITANCE VALUES LESS THAN 1.0 IN MF
VALUES ABOVE 1.0 IN MF
RESISTORS SHOULD HOLD WITHIN ± 20% WITH
120 V LINE VOLUME CONTROL AT MINIMUM AND
NO SIGNAL.

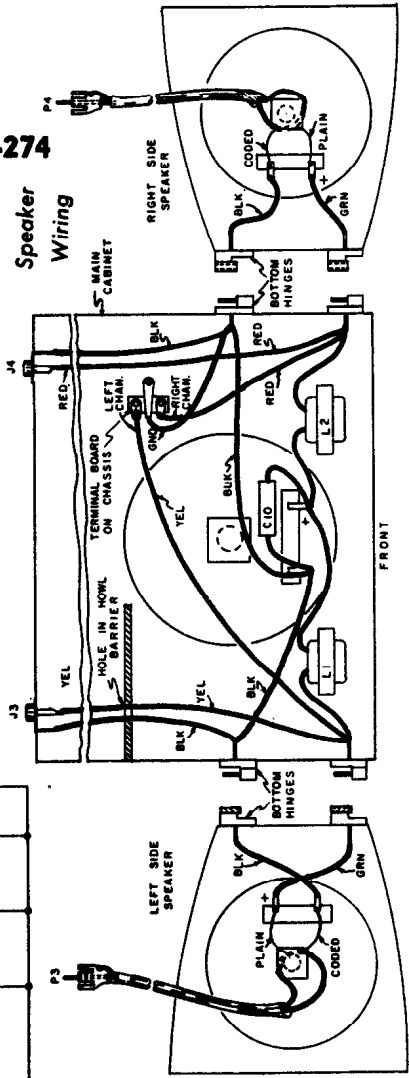

CHASSIS REMOVAL

The rear flange of the chassis is fastened to the cabinet by two bolts and the forward (front) flange is held by a retaining clip.

To remove the chassis — (1) remove the knobs, (2) remove the two screws holding the escutcheon and lift it off, (3) remove the two screws holding the changer, (4) unplug the two cables from the chassis and remove the changer, (5) remove the six screws holding the changer mounting board and the four screws holding the metal panel covering the amplifier, (6) lift off the changer mounting board and amplifier cover panel AS A UNIT, (7) remove the two bolts holding the rear flange of the chassis, (8) slide the chassis to the rear of the cabinet and lift it out.

To install the chassis, reverse the above procedure.

RCA VICTOR

MODEL VP-36

Chassis No. RS-182A

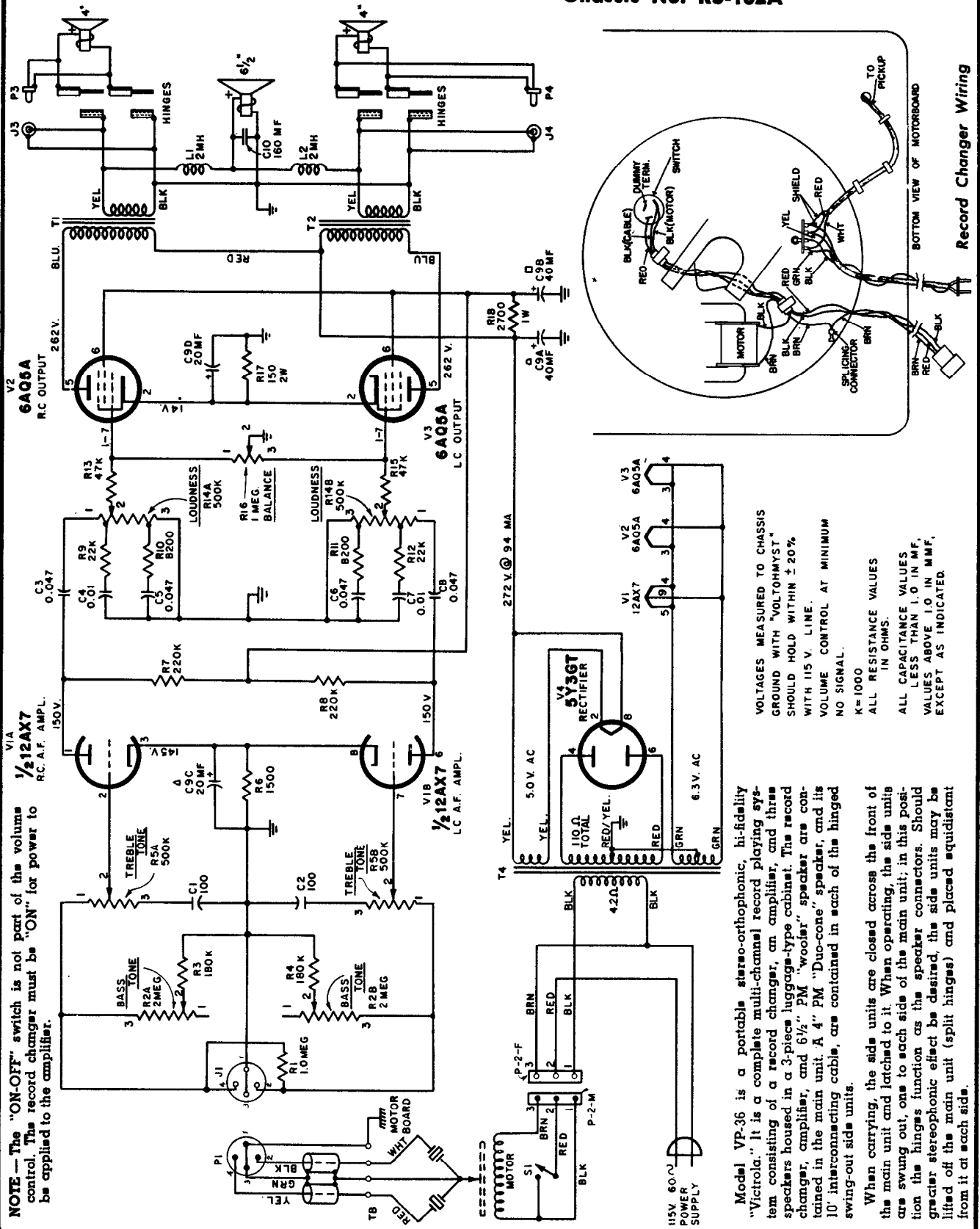

NOTE — The "ON-OFF" switch is not part of the volume control. The record changer must be "ON" for power to be applied to the amplifier.

Model VP-36 is a portable stereo-orthophonic, hi-fidelity "Victrola." It is a complete multi-channel record playing system consisting of a record changer, an amplifier, and three speakers housed in a 3-piece luggage-type cabinet. The record changer, amplifier, and 6 1/2" PM "wooler" speaker are contained in the main unit. A 4" PM "Duo-cone" speaker, and its 10' interconnecting cable, are contained in each of the hinged swing-out side units.

When carrying, the side units are closed across the front of the main unit and latched to it. When operating, the side units are swung out, one to each side of the main unit; in this position the hinges function as the speaker connectors. Should greater stereophonic effect be desired, the side units may be lifted off the main unit (split hinges) and placed equidistant from it at each side.

- VOLTAGES MEASURED TO CHASSIS GROUND WITH "VOLTOHMYST" SHOULD HOLD WITHIN ±20% WITH 115 V. LINE.
- VOLUME CONTROL AT MINIMUM NO SIGNAL.
- K=1000
- ALL RESISTANCE VALUES IN OHMS.
- ALL CAPACITANCE VALUES LESS THAN 1.0 IN MMF, VALUES ABOVE 1.0 IN MMF, EXCEPT AS INDICATED.

RCA VICTOR MODEL VP-38

Chassis No. RS-175B

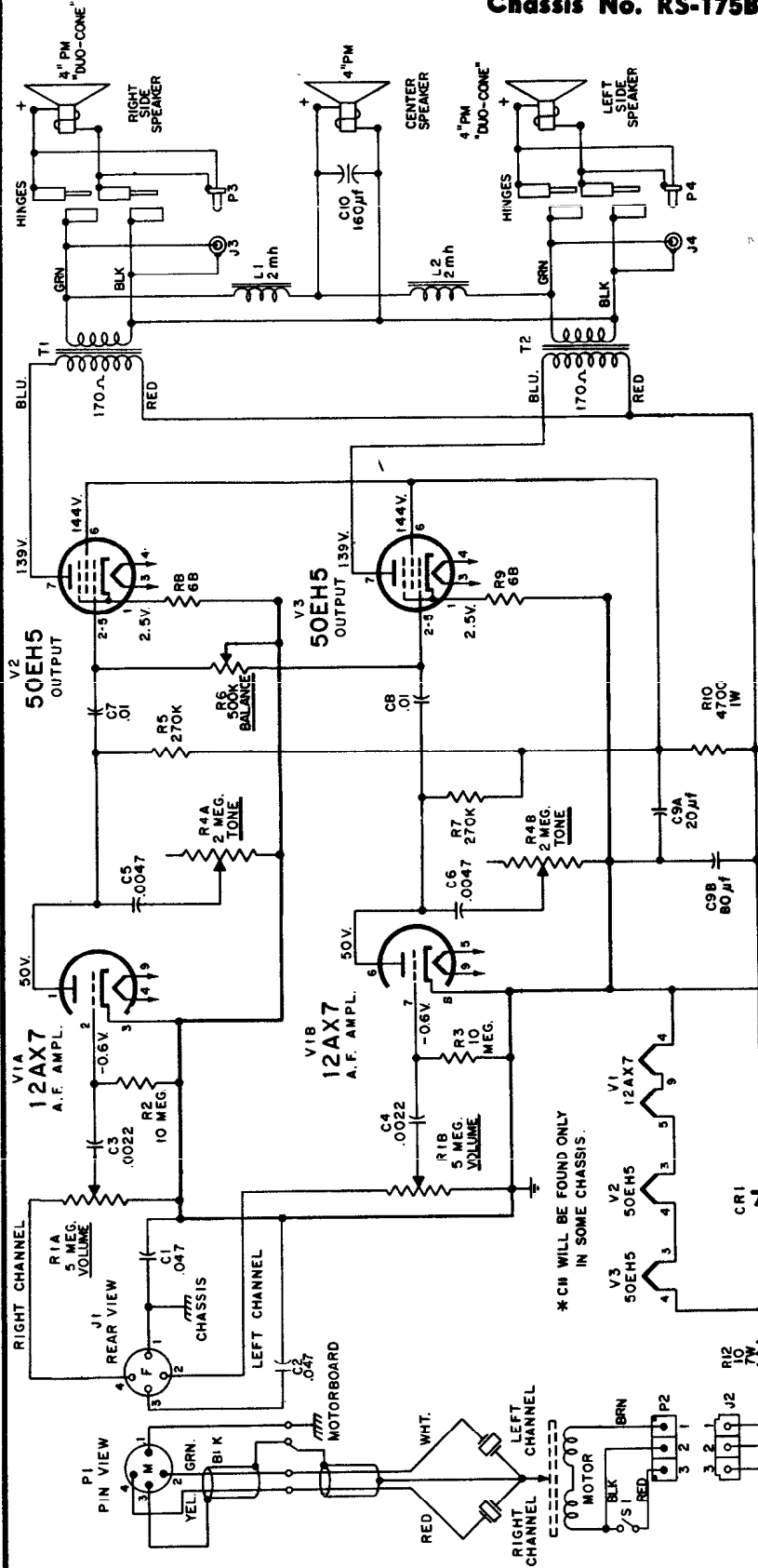

VIA 12AX7 A.F. AMPL.
V2 50EH5 OUTPUT
V3 50EH5 OUTPUT 139V.
V1B 12AX7 A.F. AMPL.

RIGHT CHANNEL
LEFT CHANNEL

PIN VIEW
REAR VIEW

MOTOR
TO PICKUP

BLK (CABLE)
REI
GRN
BLK (MOTOR)
SWITCH
YEL. SHIELD
RED
WHT

TO PICKUP

Record Changer Wiring

115V. 60VAC PWR. SUPP.
*** C1 .27μ ± 10% .400V. PAPER TUBULAR**
*** C2 .0022**
*** C3 .0022**
*** C4 .0022**
*** C5 .0047**
*** C6 .0047**
*** C7 .01**
*** C8 .01**
*** C9A 20μf**
*** C9B 60μf**
*** C10 160μf**
*** R1A 5 MEG. VOLUME**
*** R1B 5 MEG. VOLUME**
*** R1C 5 MEG. VOLUME**
*** R2 10 MEG.**
*** R3 10 MEG.**
*** R4 10 MEG.**
*** R5 270K**
*** R6 2 MEG. TONE**
*** R7 270K**
*** R8 2 MEG. TONE**
*** R9 68Ω**
*** R10 470Ω**
*** R11 170Ω**
*** R12 170Ω**
*** R13 170Ω**
*** R14 170Ω**
*** R15 170Ω**
*** R16 170Ω**
*** R17 170Ω**
*** R18 170Ω**
*** R19 170Ω**
*** R20 170Ω**
*** R21 170Ω**
*** R22 170Ω**
*** R23 170Ω**
*** R24 170Ω**
*** R25 170Ω**
*** R26 170Ω**
*** R27 170Ω**
*** R28 170Ω**
*** R29 170Ω**
*** R30 170Ω**
*** R31 170Ω**
*** R32 170Ω**
*** R33 170Ω**
*** R34 170Ω**
*** R35 170Ω**
*** R36 170Ω**
*** R37 170Ω**
*** R38 170Ω**
*** R39 170Ω**
*** R40 170Ω**
*** R41 170Ω**
*** R42 170Ω**
*** R43 170Ω**
*** R44 170Ω**
*** R45 170Ω**
*** R46 170Ω**
*** R47 170Ω**
*** R48 170Ω**
*** R49 170Ω**
*** R50 170Ω**

VOLTAGES MEASURED TO CHASSIS GROUND WITH "VOLTOHMYST" AND SHOULD HOLD WITHIN ±20%.

K = 1000. ALL RESISTANCE VALUES IN OHMS. ALL CAPACITANCE VALUES LESS THAN 1.0 IN μf, VALUES ABOVE 1.0 IN μf EXCEPT AS INDICATED.

Each channel of the dual-channel amplifier uses one-half of the 12AX7 tube as an A.F. amplifier, and one of the 50EH5 tubes as a power amplifier. The Volume and Tone controls are dual section potentiometers; one section of each control is connected in each channel, thus providing simultaneous regulation of the two channels. The Balance control is a single section potentiometer connected between the grid circuits of the two output stages; it has its variable arm grounded. Channel balance is achieved as the arm of the control moves toward one end or the other, thus decreasing the gain of one channel while concurrently increasing the gain of the other.

Multi-channel operation is accomplished by the use of three speaker systems and a filter network in the speaker circuitry. The left and right side speakers are direct connected to their respective output transformers. Two reactors (L1 and L2) are connected in series between the high sides of the two output transformer secondaries, and the center speaker is connected to the junction of the two reactors. The low (ground) side of

the three speakers are connected together. A capacitor (C10) is connected across the center speaker.

The side speakers are designed primarily to reproduce only those frequencies in the middle and higher ranges. The two 2mh reactors (L1 and L2) pass and combine the low frequencies of the two side channels to the center speaker. The 160 μf capacitor (C10) acts as an additional bypass to filter out any of the middle range and higher frequencies thus preventing their reproduction by the center speaker. To prevent electrical cancellation of frequencies at the center speaker, the side-channel signals must be in-phase; this condition is achieved by the use of an "in-phase" pickup in this system the middle range and higher frequencies, wherein lay the greatest stereophonic effect, are reproduced only in the left and right side speakers; and the combined low frequencies, of the two side channels, are reproduced in the center speaker. The cross-over frequency is approximately 200 cycles.

VOLUME R-21, MOST-OFTEN-NEEDED 1961 RADIO SERVICING INFORMATION

RCA Victor Model BK-1, Chassis RS-187, and Speakers DK-109, DK-110, DK-111

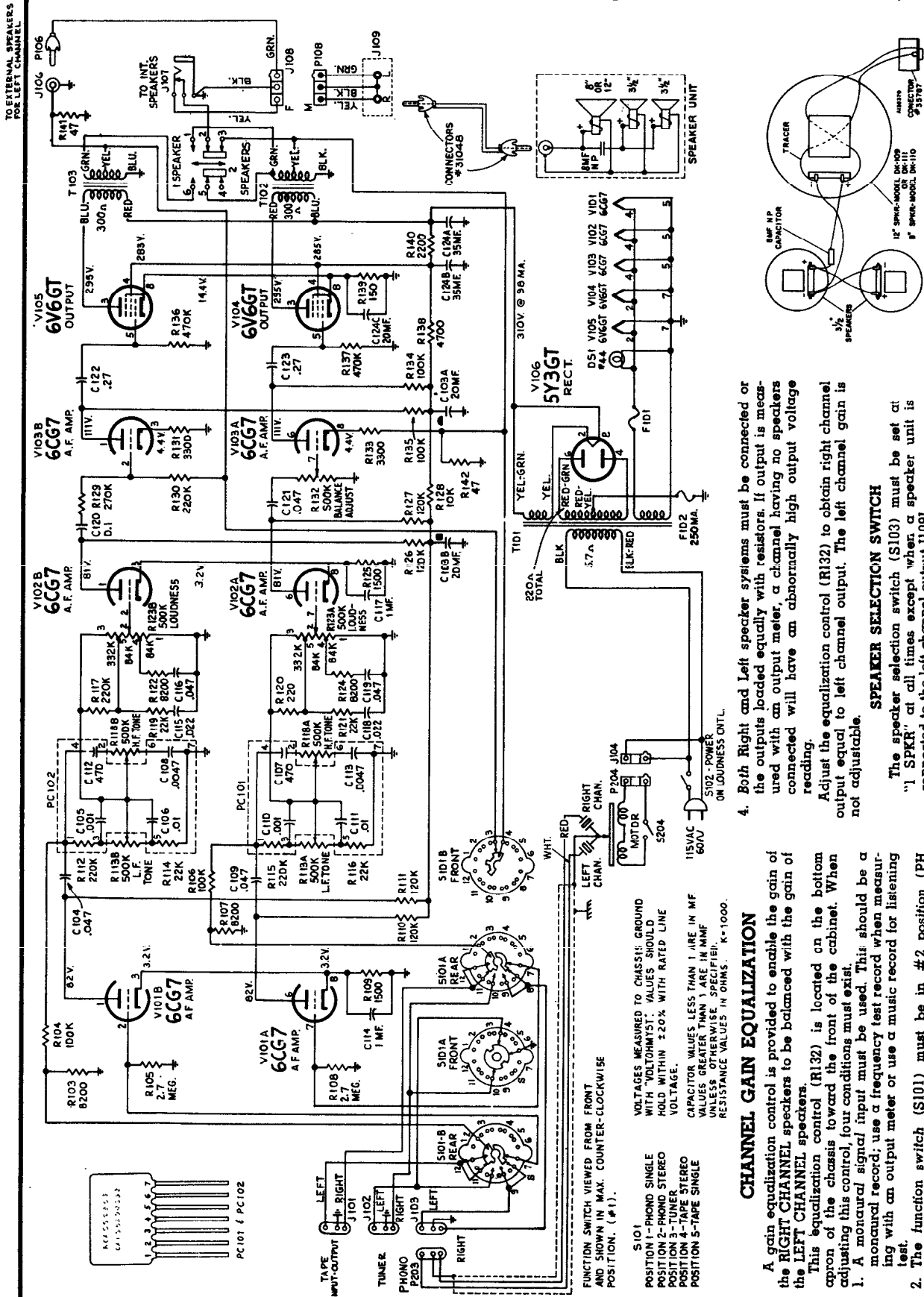

Speaker Connection Diagram

4. Both Right and Left speaker systems must be connected or the outputs loaded equally with resistors. If output is measured with an output meter, a channel having no speakers connected will have an abnormally high output voltage reading. Adjust the equalization control (R132) to obtain right channel output equal to left channel output. The left channel gain is not adjustable.

SPEAKER SELECTION SWITCH

The speaker selection switch (S103) must be set at "1 SPKR" at all times except when a speaker unit is connected to the left channel output J109L. When only one speaker unit is used it should be connected to J109R. For stereophonic reproduction, speaker units must be connected to both J109R and J109L. The speaker selection switch must be set at "2 SPKR".

A gain equalization control is provided to enable the gain of the RIGHT CHANNEL speakers to be balanced with the gain of the LEFT CHANNEL speakers. This equalization control (R132) is located on the bottom capron of the chassis toward the front of the cabinet. When adjusting this control, four conditions must exist.

1. A monaural signal input must be used. This should be a monaural record; use a frequency test record when measuring with an output meter or use a music record for listening test.
2. The function switch (S101) must be in #2 position (PH STEREO). This enables the two channels to have independent outputs.
3. The speaker selection switch (S103) must be in the "2 SPKRS" position. This is necessary for the two channels to have independent outputs.

CHANNEL GAIN EQUALIZATION

VOLTAGES MEASURED TO CHASSIS GROUND WITH "VOLTOHMIST". VALUES SHOULD HOLD WITHIN ±20% WITH RATED LINE VOLTAGE. CAPACITOR VALUES LESS THAN 1 µF ARE IN MF UNLESS OTHERWISE SPECIFIED. R=1000. RESISTANCE VALUES IN OHMS.

S101 FUNCTION SWITCH VIEWED FROM FRONT AND SHOWN IN MAX. COUNTER-CLOCKWISE POSITION. (#1).

- POSITION 1-PHONO SINGLE
- POSITION 2-PHONO STEREO
- POSITION 3-TUNER
- POSITION 4-TAPE STEREO
- POSITION 5-TAPE SINGLE

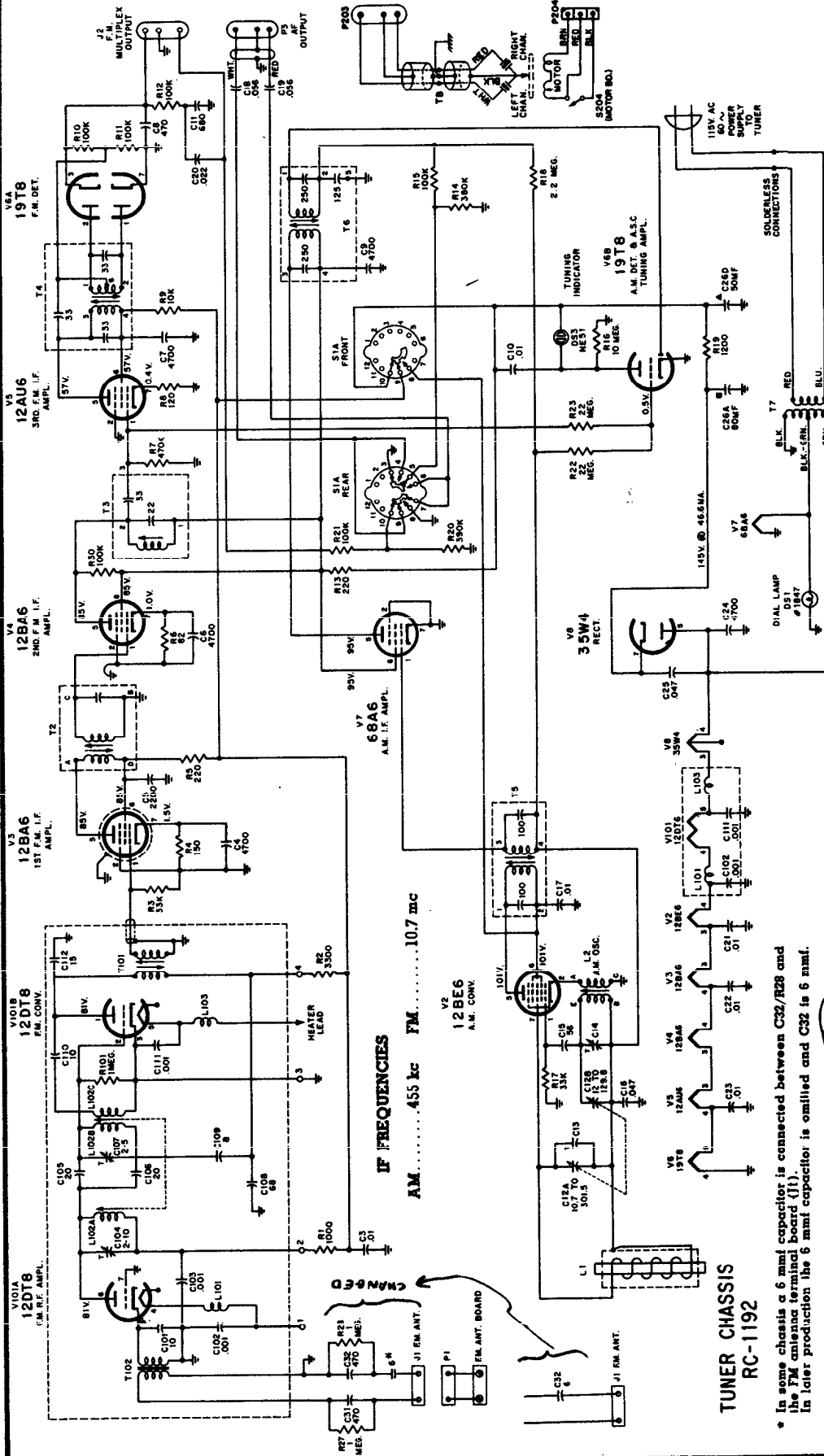

RCA VICTOR

Models TPM-11, TPM-12, TPM-13, VC-13, VCR-13, VC-14, VCR-14, VC-16, PM-17, VC-17, PM-18, and VC-22, all use tuner RC-1192. Some of these combinations use Pre-Amplifier RS-179 and Power Amplifier RS-177A. Others use amplifier RS-171D or RS-171F. Material above and on the next two pages.

* In some chassis a 6 mfd capacitor is connected between C32/R28 and the FM antenna terminal board (11). In later production the 6 mfd capacitor is omitted and C32 is 6 mfd.

K=1000
 ALL RESISTANCE VALUES IN OHMS.
 ALL CAPACITANCE VALUES LESS THAN 1.0 IN MF.
 VALUES ABOVE 1.0 IN MF EXCEPT AS NOTED.
 *VOLTAGES MEASURED TO CHASSIS GROUND WITH "VOLTHYST." SHOULD HOLD WITHIN ±25% AT 15V LINE. VOLUME CONTROL MINIMUM AND NO SIGNAL.

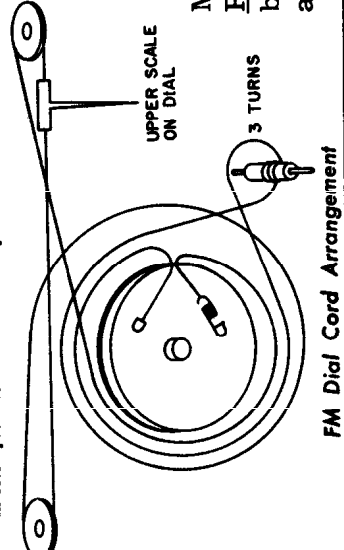

K = 1000
 ALL RESISTANCE VALUES IN OHMS.
 ALL CAPACITANCE VALUES LESS THAN 1.0 IN MF.
 VOLTAGES MEASURED TO CHASSIS GROUND WITH
 AT 115 V. LINE. VOLUME CONTROL MINIMUM
 AND NO SIGNAL.
 *VOLTHMST. SHOULD HOLD WITHIN ± 20%
 VALUES ABOVE 1.0 IN MMF EXCEPT AS NOTED.

**AMP. CHASSIS
 RS-171D**

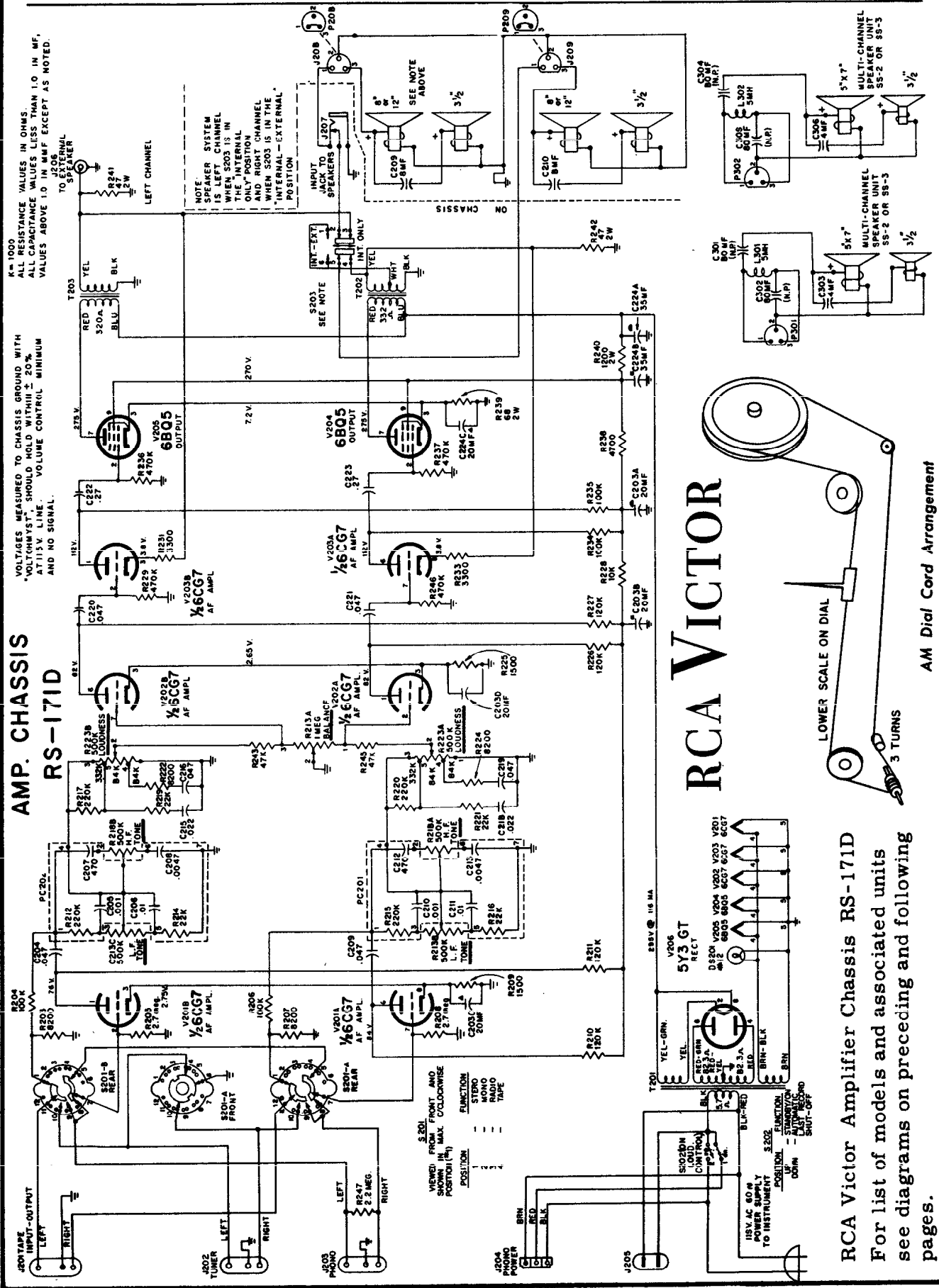

VIEWED FROM FRONT AND
 SHOWN IN MAX. COUNTERCLOCKWISE
 POSITION (1)
 POSITION 2
 POSITION 3

RCA VICTOR

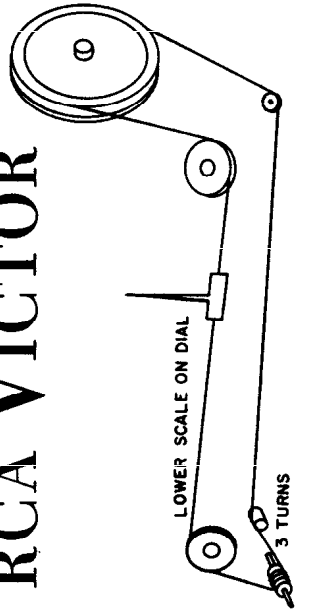

RCA Victor Amplifier Chassis RS-171D
 For list of models and associated units
 see diagrams on preceding and following
 pages.

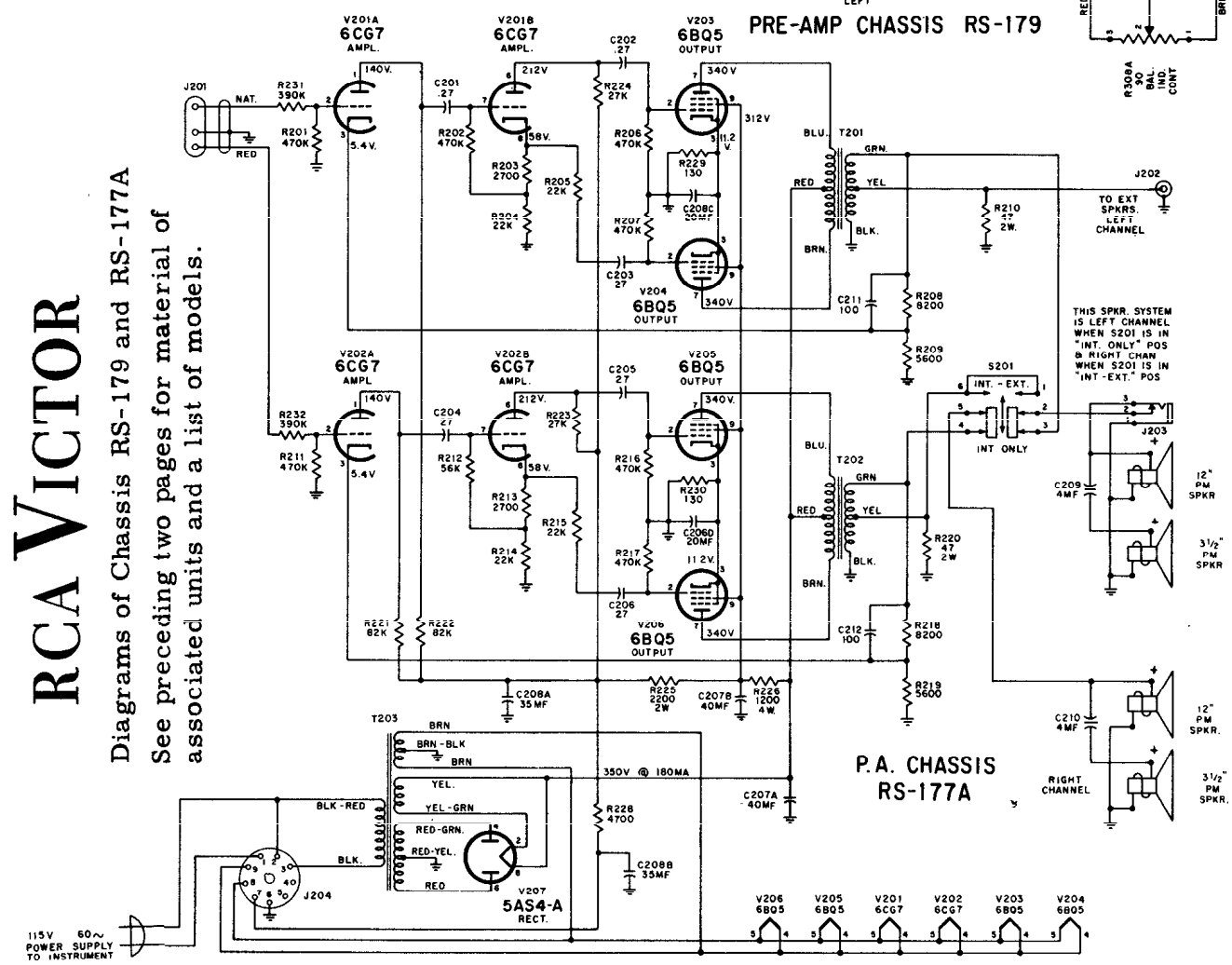
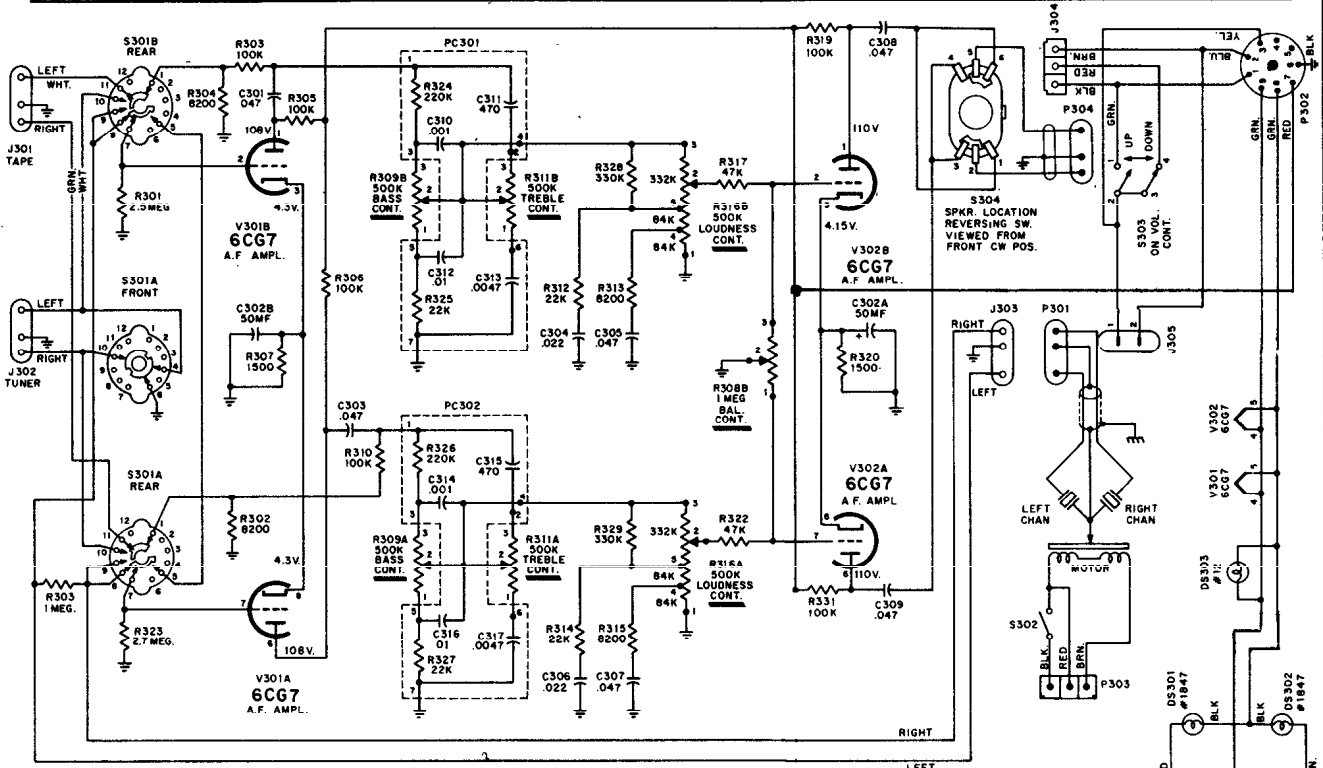

RCA VICTOR
 Diagrams of Chassis RS-179 and RS-177A
 See preceding two pages for material of
 associated units and a list of models.

THIS SPKR. SYSTEM IS LEFT CHANNEL WHEN S201 IS IN "INT. ONLY" POS & RIGHT CHAN WHEN S201 IS IN "INT.-EXT." POS

SYLVANIA

**CHASSIS 630-5 THRU-8
651-1 THRU-4**

Models 5C10B, P, 5C11B, T, 5C12R, T, W, 5T10B, P, 5T11B, T, 5T12R, T, W, 1100, 1111, 1160, 1212, 1219, 1286, 1300, 1301, 1306, 1309, 1322, 1400, 1512, 1519, 1600, 1701, 1704, 1708, and 1709

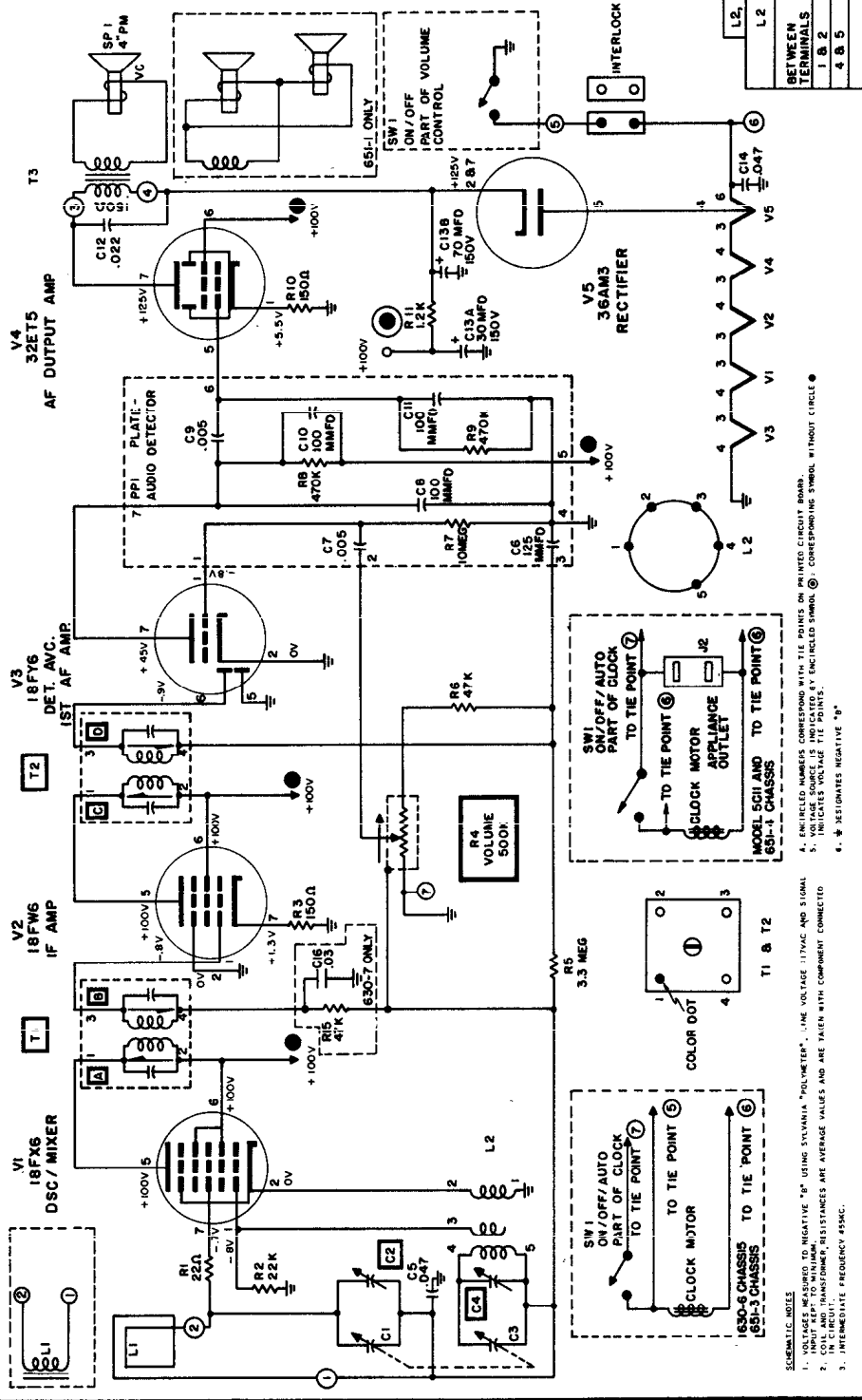

L2, T1 & T2 RESISTANCE CHART

T1		T2	
BETWEEN TERMINALS	RES. Ω	BETWEEN TERMINALS	RES. Ω
1 & 2	1.0	1 & 2	15
4 & 5	7	3 & 4	15
		1 & 2	15
		3 & 4	15

TOP PARTS LAYOUT

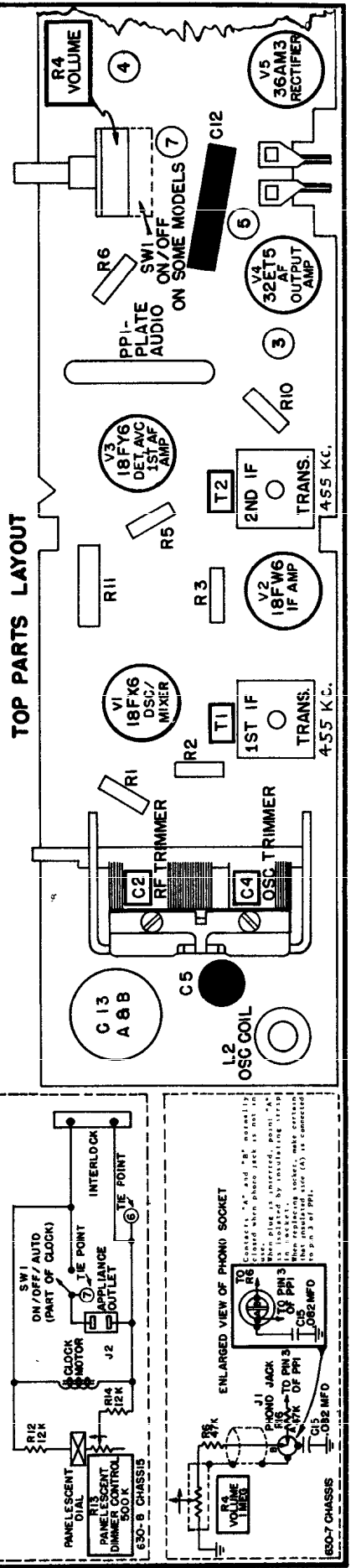

4. ENRICHED NUMBERS CORRESPOND WITH TIE POINTS ON PRINTED CIRCUIT BOARD.
5. INDICATES VOLTAGE TIE POINTS.
6. * DESIGNATES NEGATIVE "B".

SCHEMATIC NOTES
1. VOLTAGE MEASURED TO NEGATIVE "B" USING SYLVANIA "POLYMER" LINE VOLTAGE 177MAC AND SIGNAL
2. COIL AND TRANSFORMER RESISTANCES ARE AVERAGE VALUES AND ARE TAKEN WITH COMPONENT CONNECTED
3. INTERMEDIATE FREQUENCY 455KC.

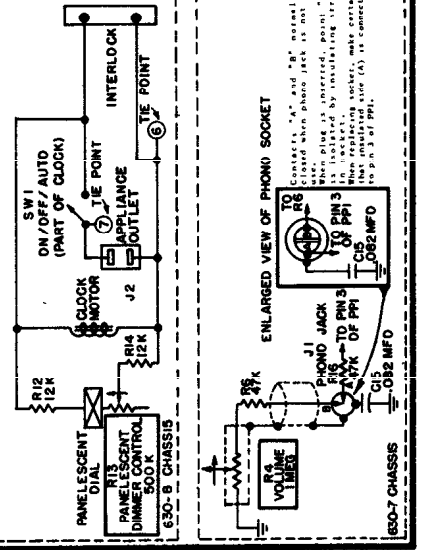
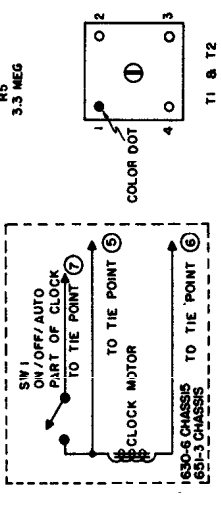

SYLVANIA

CHASSIS: 631-2,-3
MODELS: 5C13, 5T13

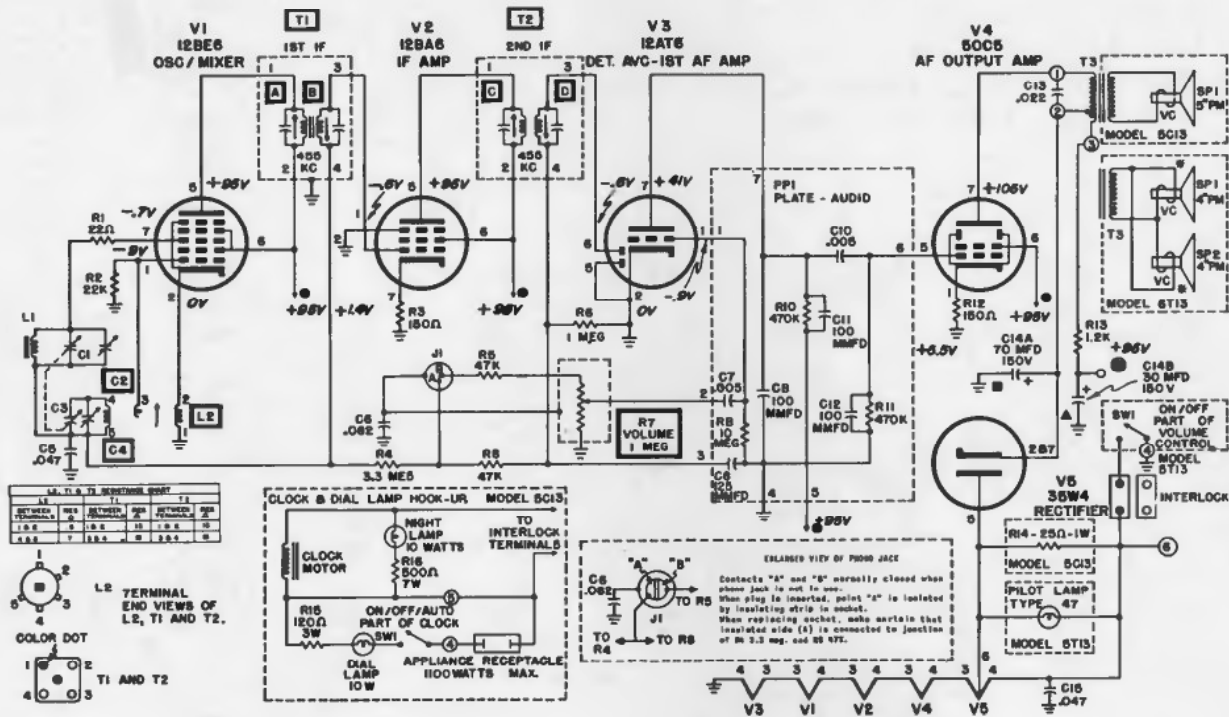

I. F. 455 KC. Encircled numbers correspond with tie points on printed board. Voltage source is indicated by encircled dot symbol; corresponding symbol dot without circle is voltage tie point. Ground \perp is B- and reference point for voltage measurements.

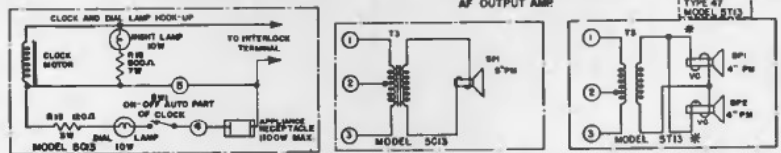
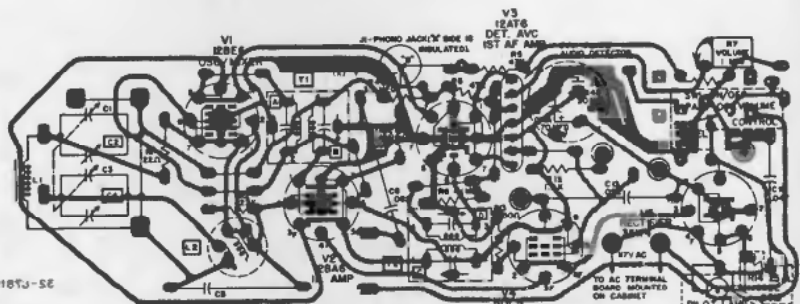

5T13 - Dial Drive & Speaker Assm.

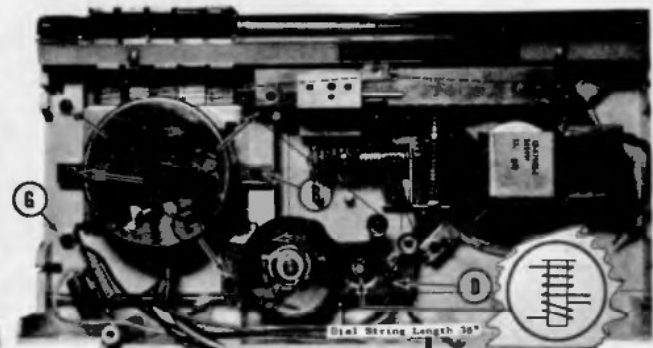

5C13 - Clock, Dial Drive & Speaker Assm.

SYLVANIA

CHASSIS: 632-3
MODELS: 6T14 SERIES

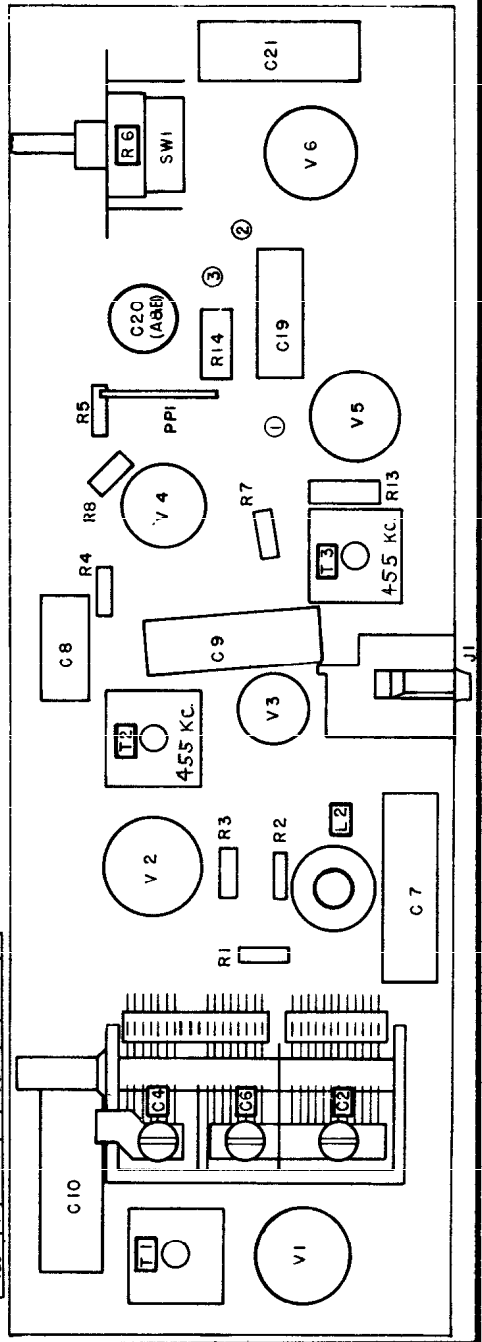
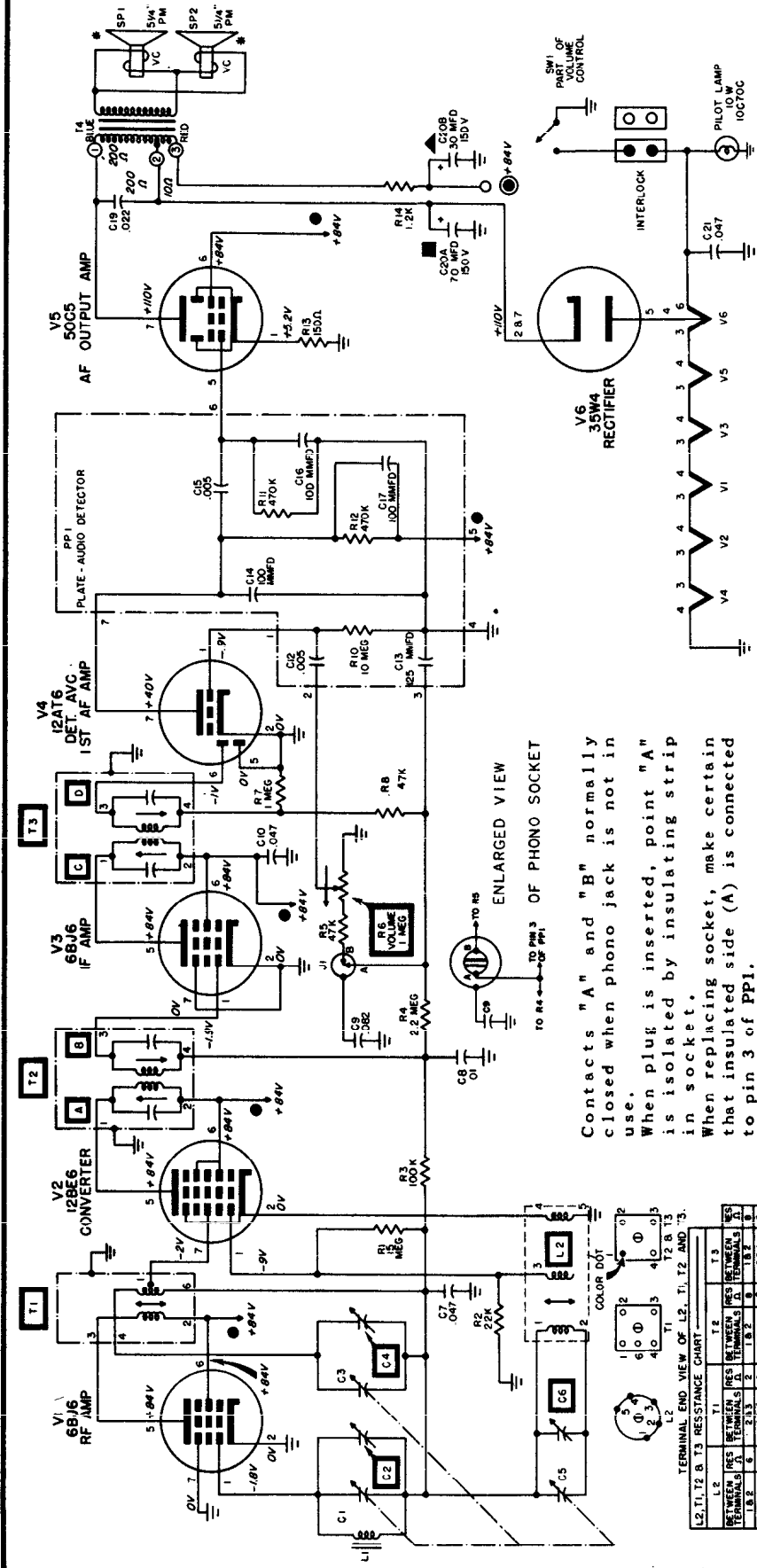

CHASSIS: 1-647-1
MODELS: 45C13, 45C14

SYLVANIA

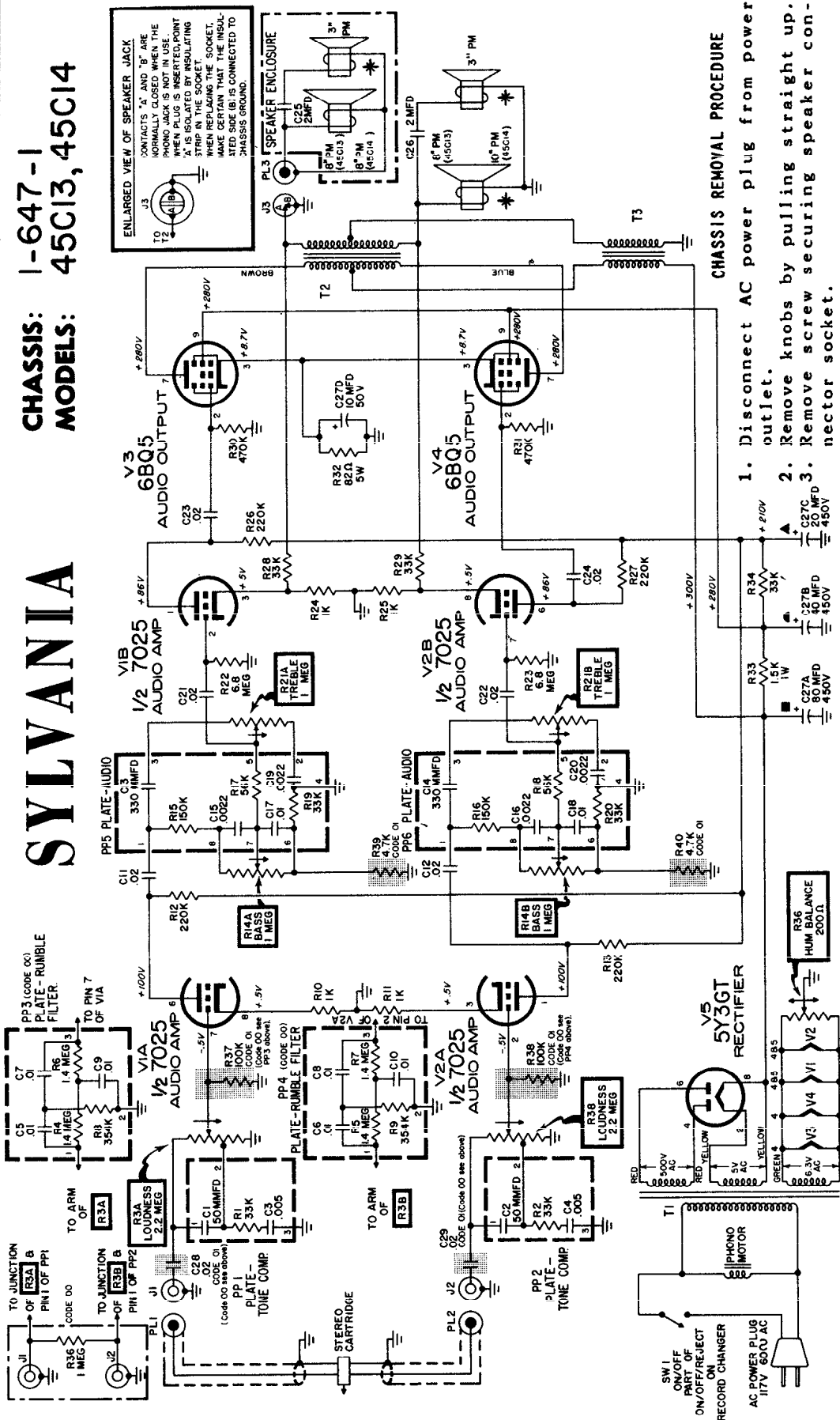

ENLARGED VIEW OF SPEAKER JACK
CONTACTS "A" AND "B" ARE NORMALLY CLOSED WHEN THE PHONO JACK IS NOT IN USE. THE "A" PLUG IS INSULATING STRIP IN THE SOCKET. WHEN REPLACING THE SOCKET, MAKE CERTAIN THAT THE INSULATED SIDE (B) IS CONNECTED TO CHASSIS GROUND.

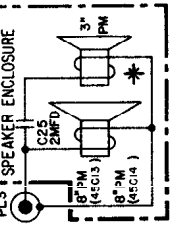

CHASSIS REMOVAL PROCEDURE

1. Disconnect AC power plug from power outlet.
2. Remove knobs by pulling straight up.
3. Remove screw securing speaker connector socket.
4. Identify and disconnect record changer motor leads, signal input leads and speaker leads.
5. While supporting chassis remove the three (3) screws securing chassis mounting board to cabinet. Remove chassis and board.
6. For under chassis tests, etc. remove the four (4) screws securing chassis to board. Remove board.

SCHEMATIC NOTES

1. VOLTAGES SHOWN ARE AVERAGE READINGS MEASURED TO CHASSIS WITH NO SIGNAL INPUT. VARIATIONS MAYBE NOTED DUE TO NORMAL PRODUCTION TOLERANCES.
2. LINE VOLTAGE 117 VOLT 60 CYCLE.
3. LOUDNESS, BASS AND TREBLE CONTROLS ARE DUAL GANGED CONTROLS.
4. SHADED AREAS DESIGNATE CODE CHANGES.
5. ALL CAPACITORS IN MICROFARADS UNLESS OTHERWISE SPECIFIED.
6. * INDICATE COLOR DOT ON SPEAKERS FOR CORRECT PHASING.
7. ≡ DESIGNATE CHASSIS GROUND.

SYLVANIA

CHASSIS: 649-1,-2
MODELS: 5PI6
 2300,2400,2500,
 2600,2700 SERIES

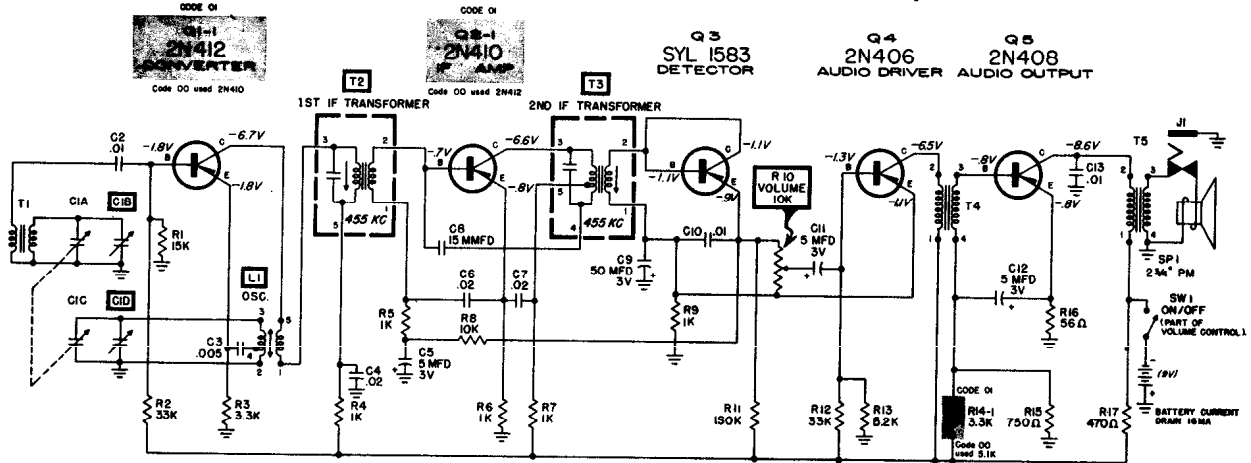

CHASSIS 649-1

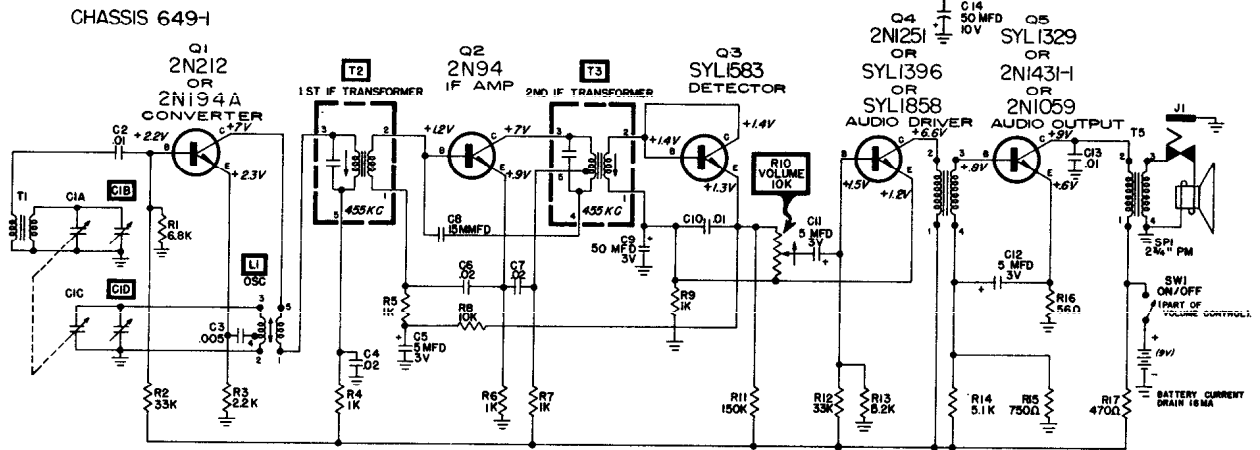

CHASSIS 649-2

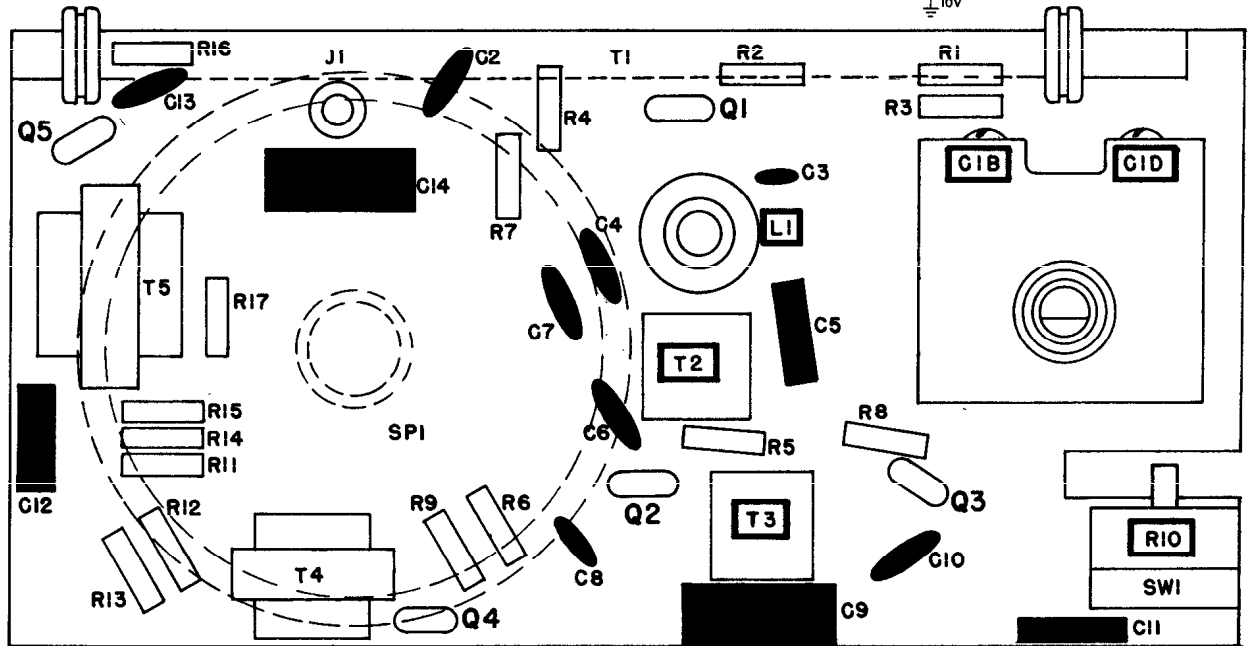

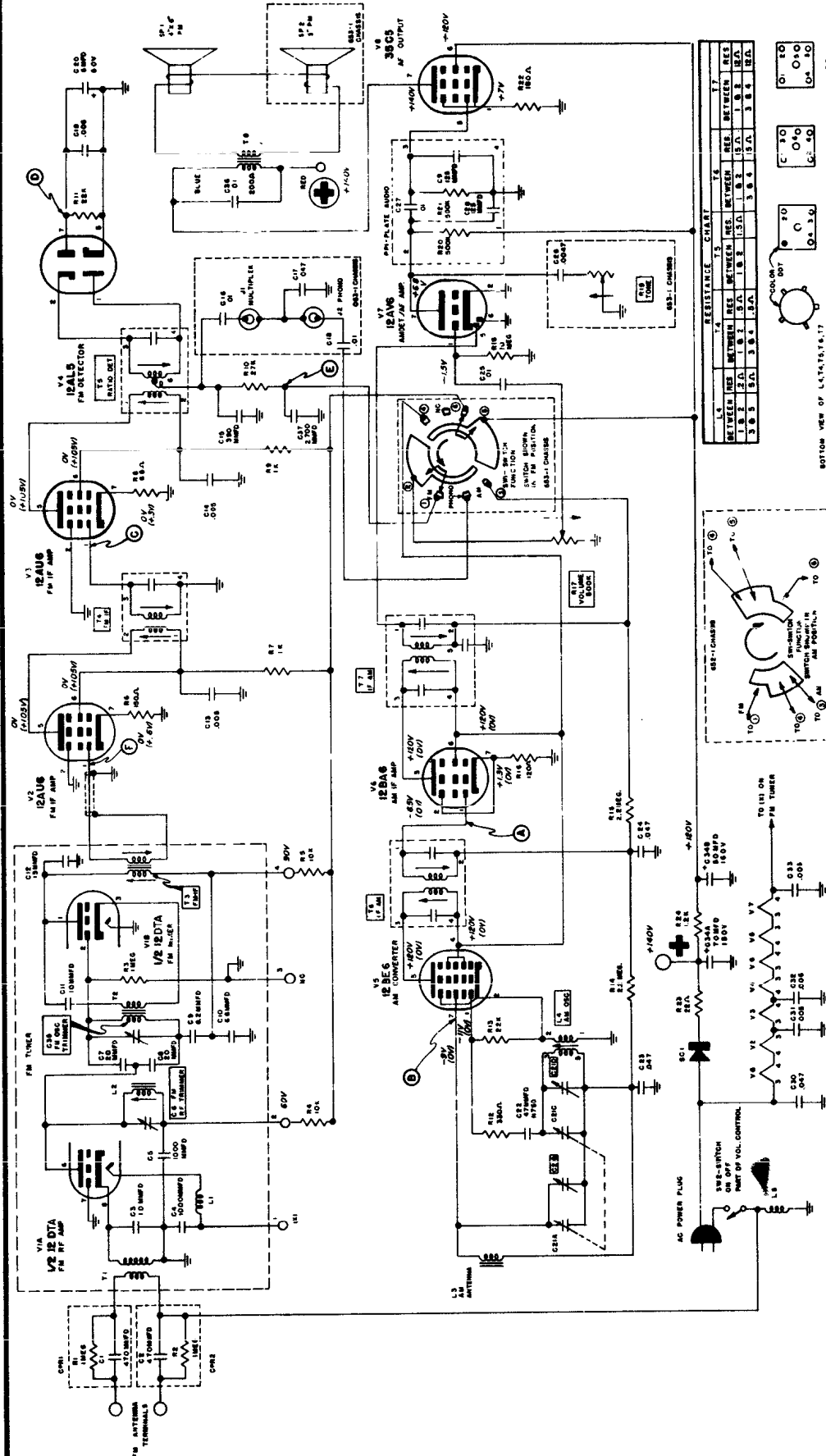

SYLVANIA

CHASSIS: 652-1/653-1
MODELS: 8FI5, 8FI6

SPECIFICATIONS

FREQUENCY RANGE (AM) 540KC to 1650KC
 FREQUENCY RANGE (FM) 88MC to 108MC
 POWER SUPPLY 117 VOLTS, 60 CYCLE (AC)
 POWER CONSUMPTION..... 35 WATTS
 INTERMEDIATE FREQUENCY (IF) AM 455KC
 INTERMEDIATE FREQUENCY (IF) FM 10.7MC

DRIVE STRING REPLACEMENT

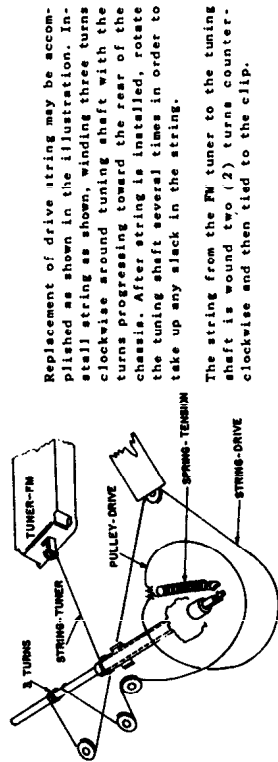

Replacement of drive string may be accomplished as shown in the illustration. Install string as shown, winding three turns clockwise around tuning shaft with the turns progressing toward the rear of the chassis. After string is installed, rotate the tuning shaft several times in order to take up any slack in the string.

The string from the FM tuner to the tuning shaft is wound two (2) turns counter-clockwise and then tied to the clip.

SYLVANIA

CHASSIS: 661-1
MODEL 4P14, 4P15

9 VOLTS

SWI ON/OFF
PART OF VOLUME
CONTROL

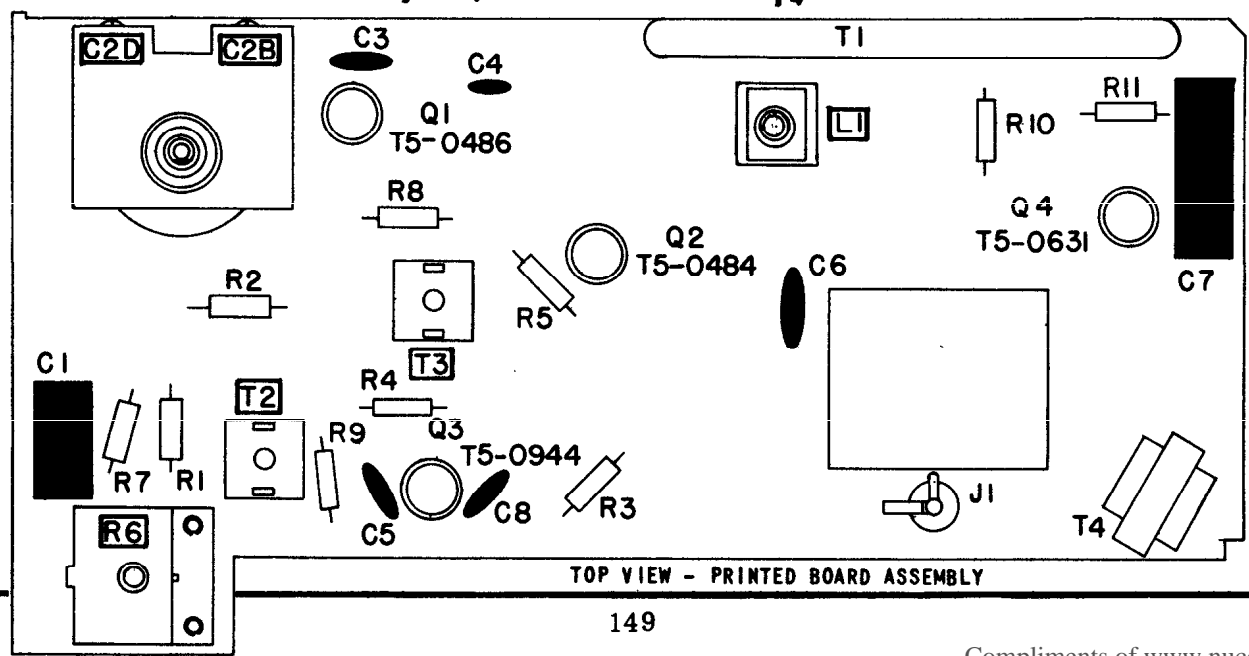
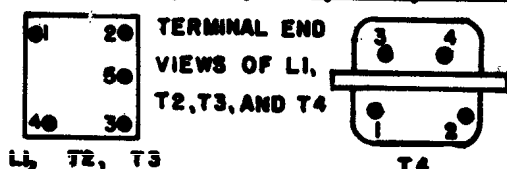
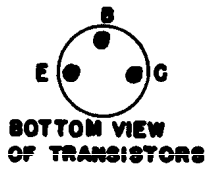
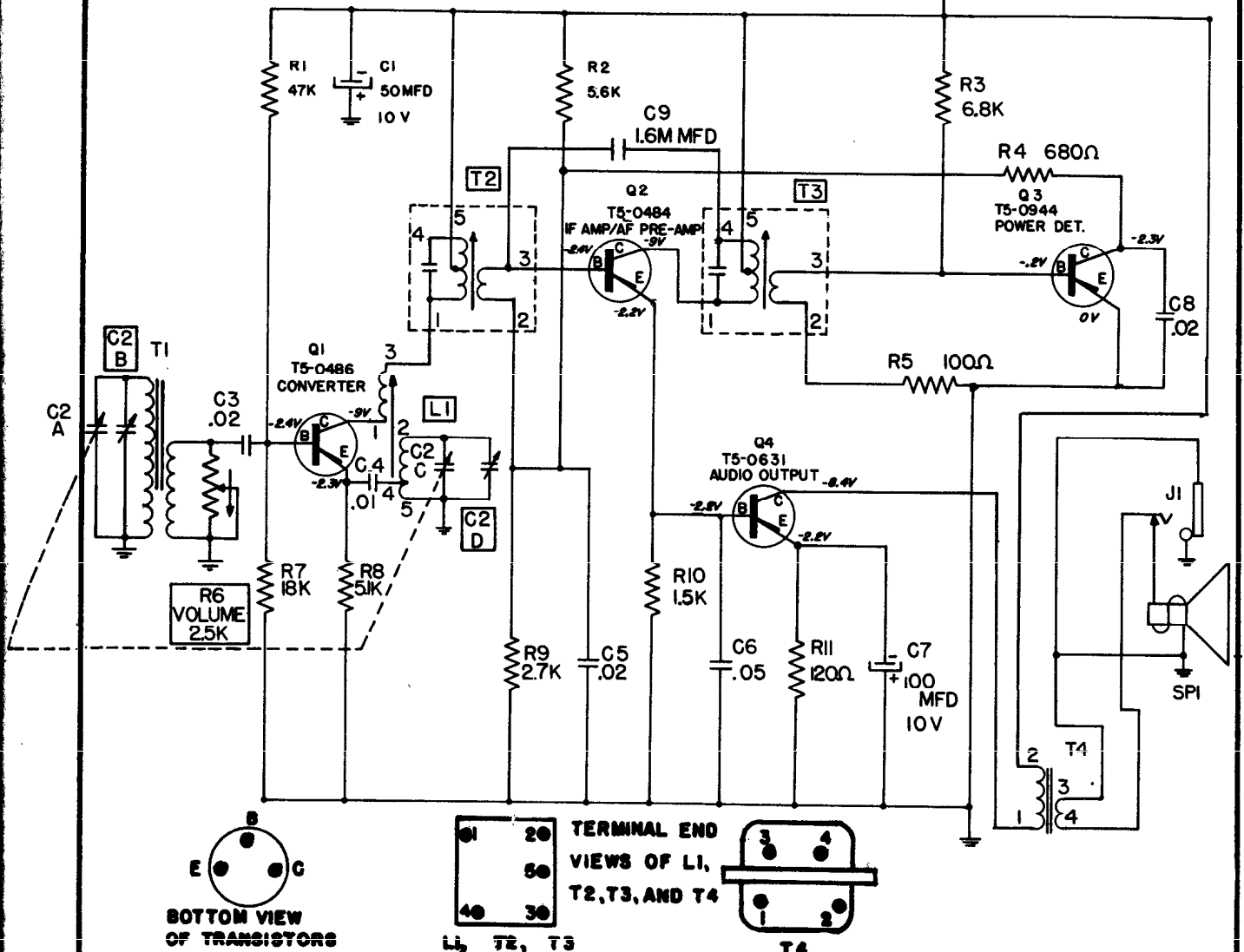

SYLVANIA

CHASSIS: 668-1,-2
MODELS: 4C09, 4C15, 4T09,
4T15 SERIES

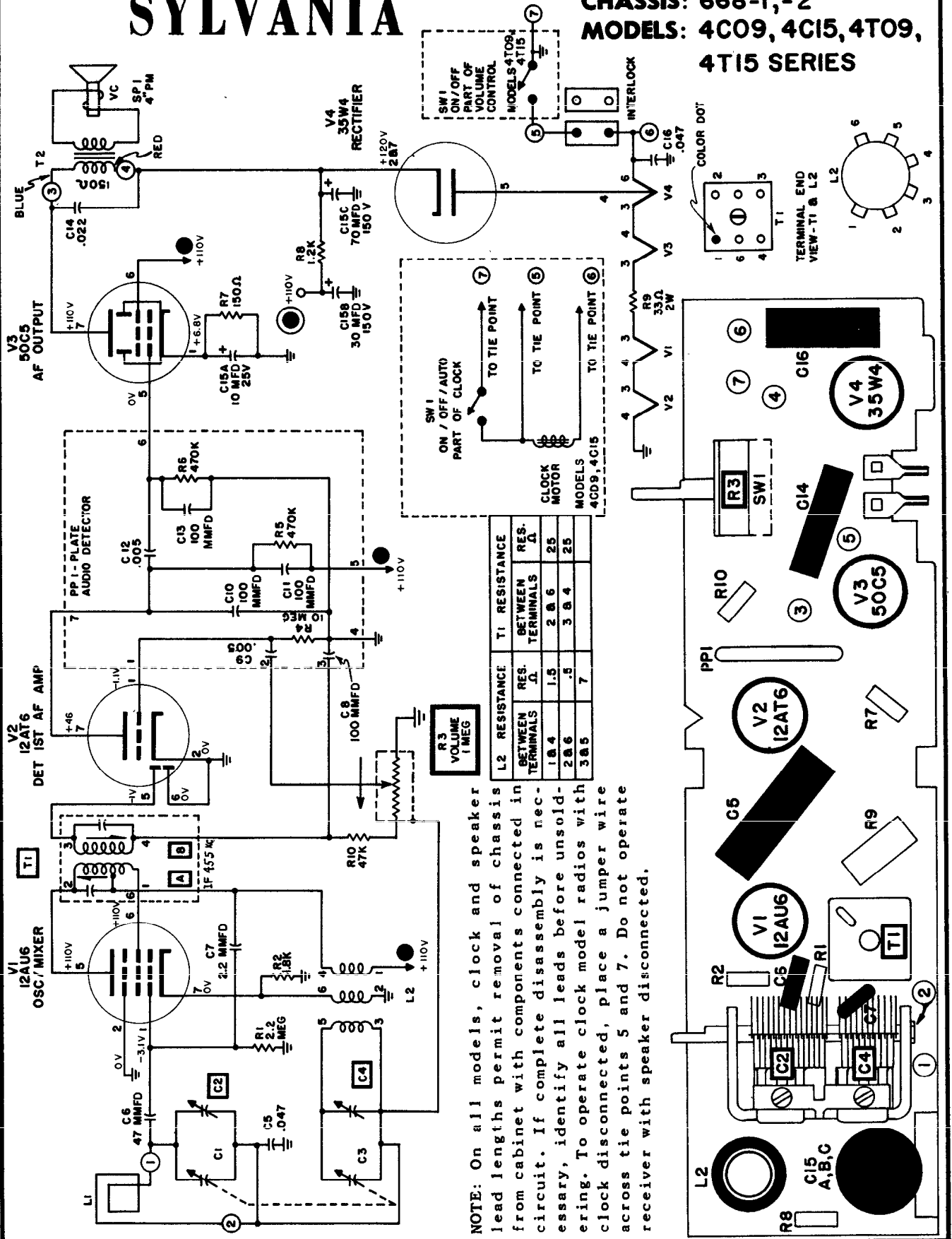

SYLVANIA

CHASSIS: 673-1
MODELS: 8P18 SERIES

RESISTANCE CHART											
L1	T2	T3	T4	T5	T6						
BETWEEN	RES	BETWEEN	RES	BETWEEN	RES	BETWEEN	RES	BETWEEN	RES	BETWEEN	RES
102	5Ω	103	35Ω	103	35Ω	102	25Ω	102	300Ω	204	100Ω
105	5Ω	104	75Ω	104	75Ω	103	5Ω	304	150Ω	203	55Ω
304	Ω	205	Ω	205	Ω	405	Ω	305	250Ω		

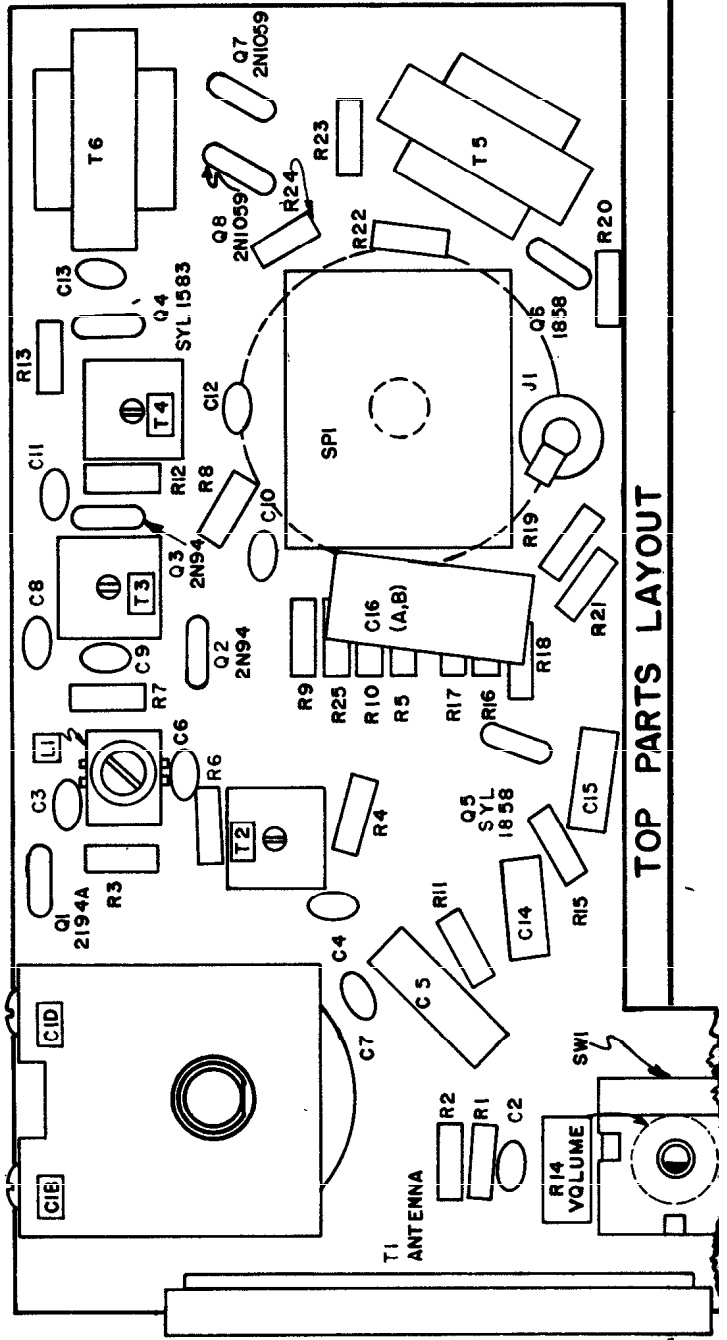
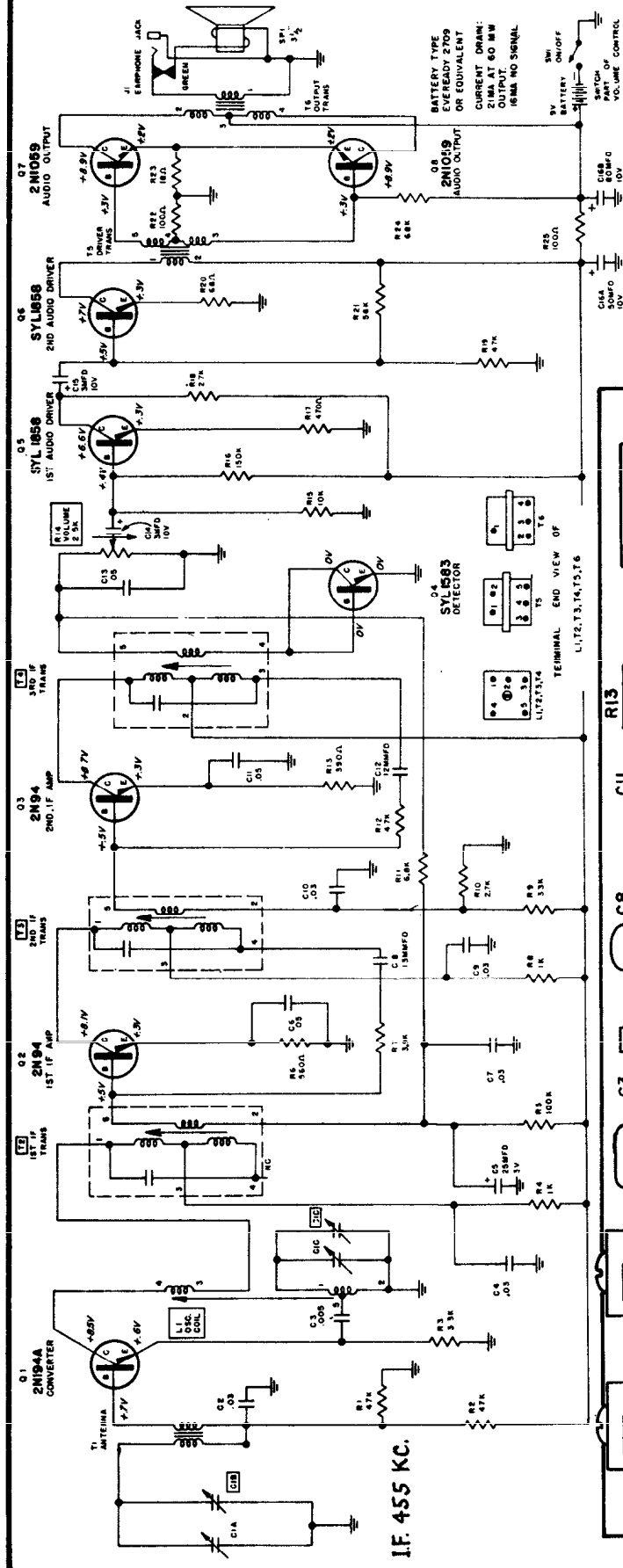

TOP PARTS LAYOUT

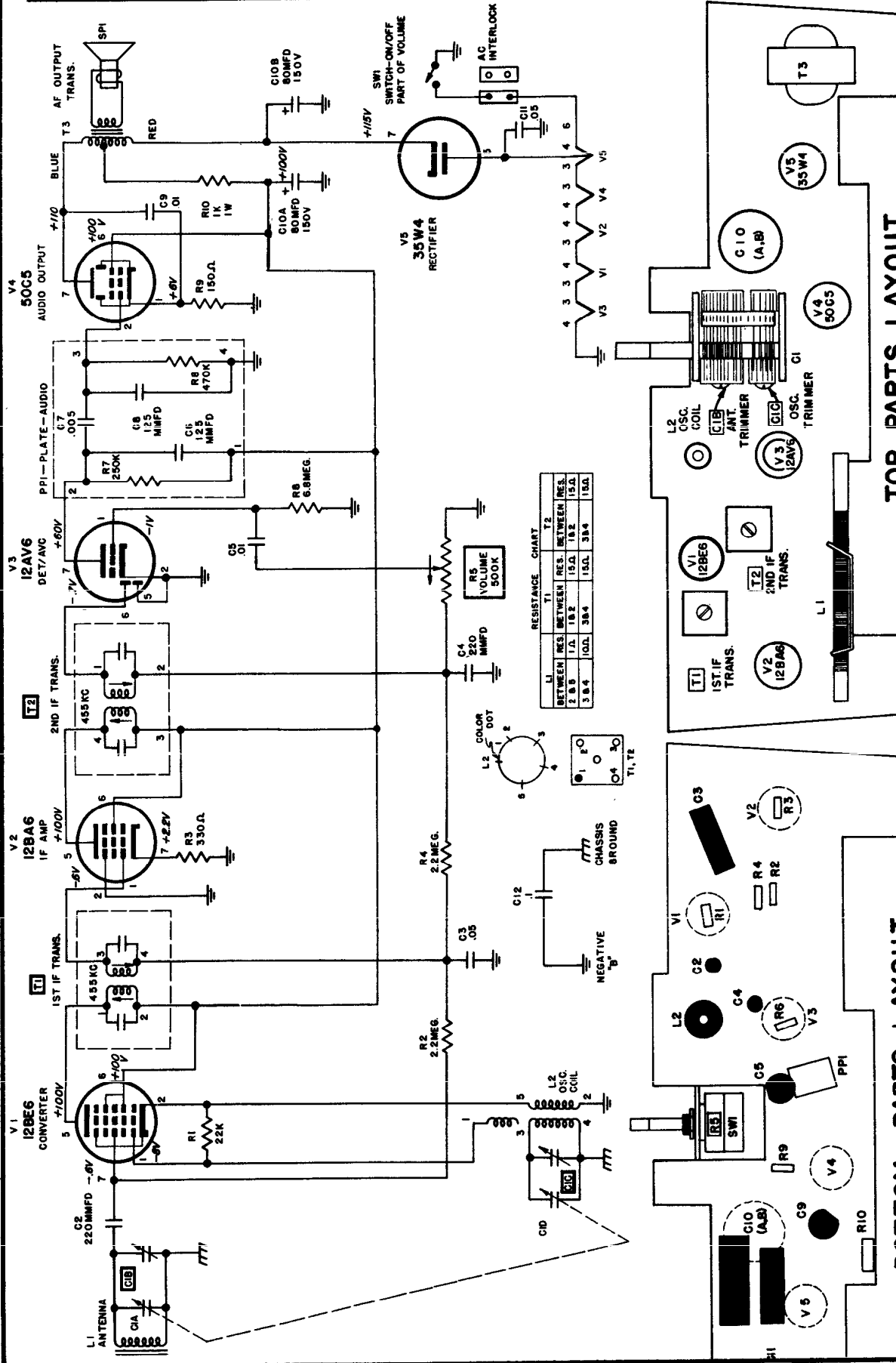

TOP PARTS LAYOUT

BOTTOM PARTS LAYOUT

CHASSIS: 676-I
MODELS: 5T17

SYLVANIA

DESIGNATES NEGATIVE "B".
CAPACITANCE IN MICROFARADS UNLESS OTHERWISE SPECIFIED.

SYLVANIA

CHASSIS: 677-1
MODELS: 6F17

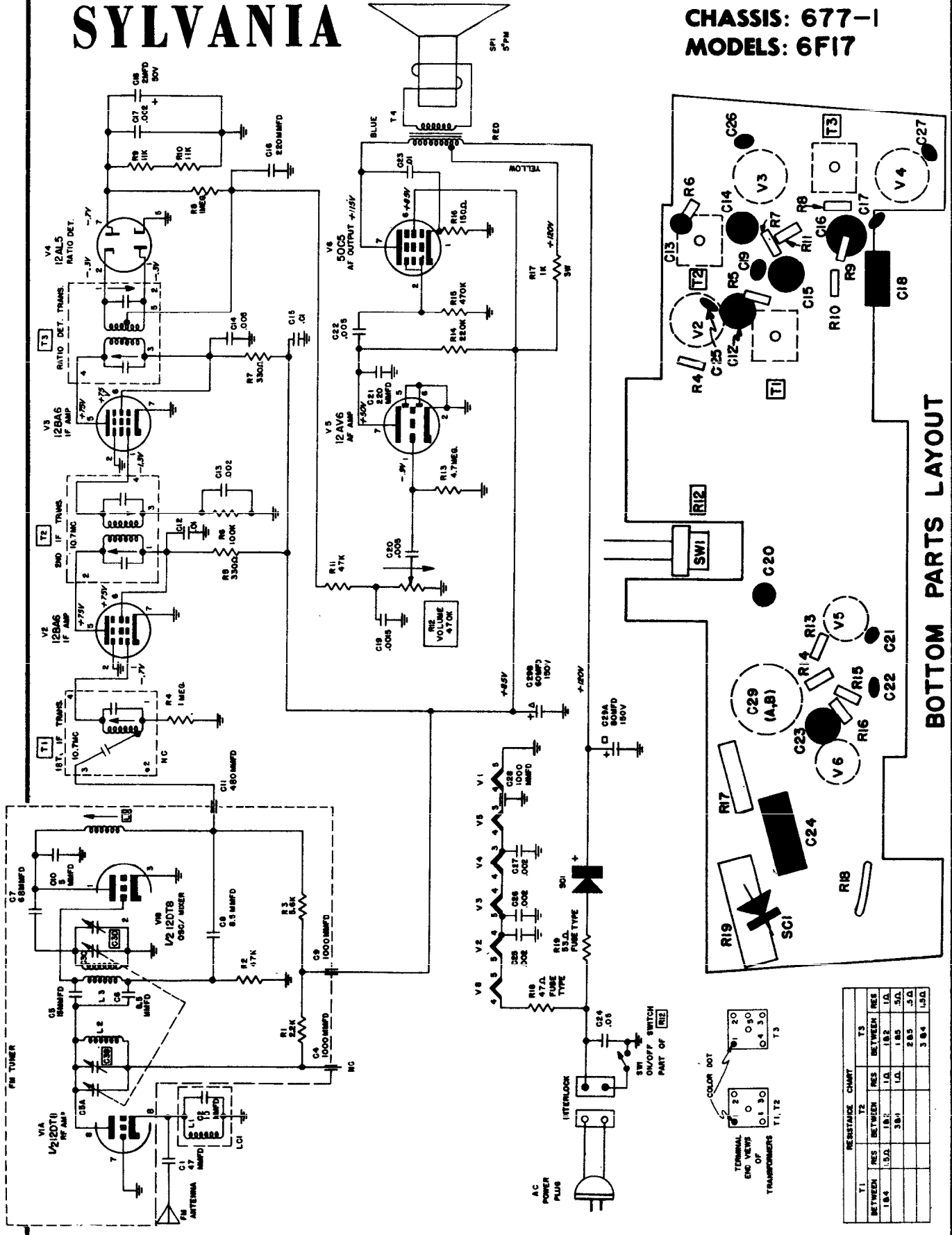

BOTTOM PARTS LAYOUT

RESISTANCE CHART		T3	
T1	RES BETWEEN	RES BETWEEN	RES
	1.5-1	1.0	1.82
	1.8-4	3.0-1	1.85
		2.85	5.0
		3.84	4.50

SYLVANIA

CHASSIS: 678-1
MODELS: 6F18

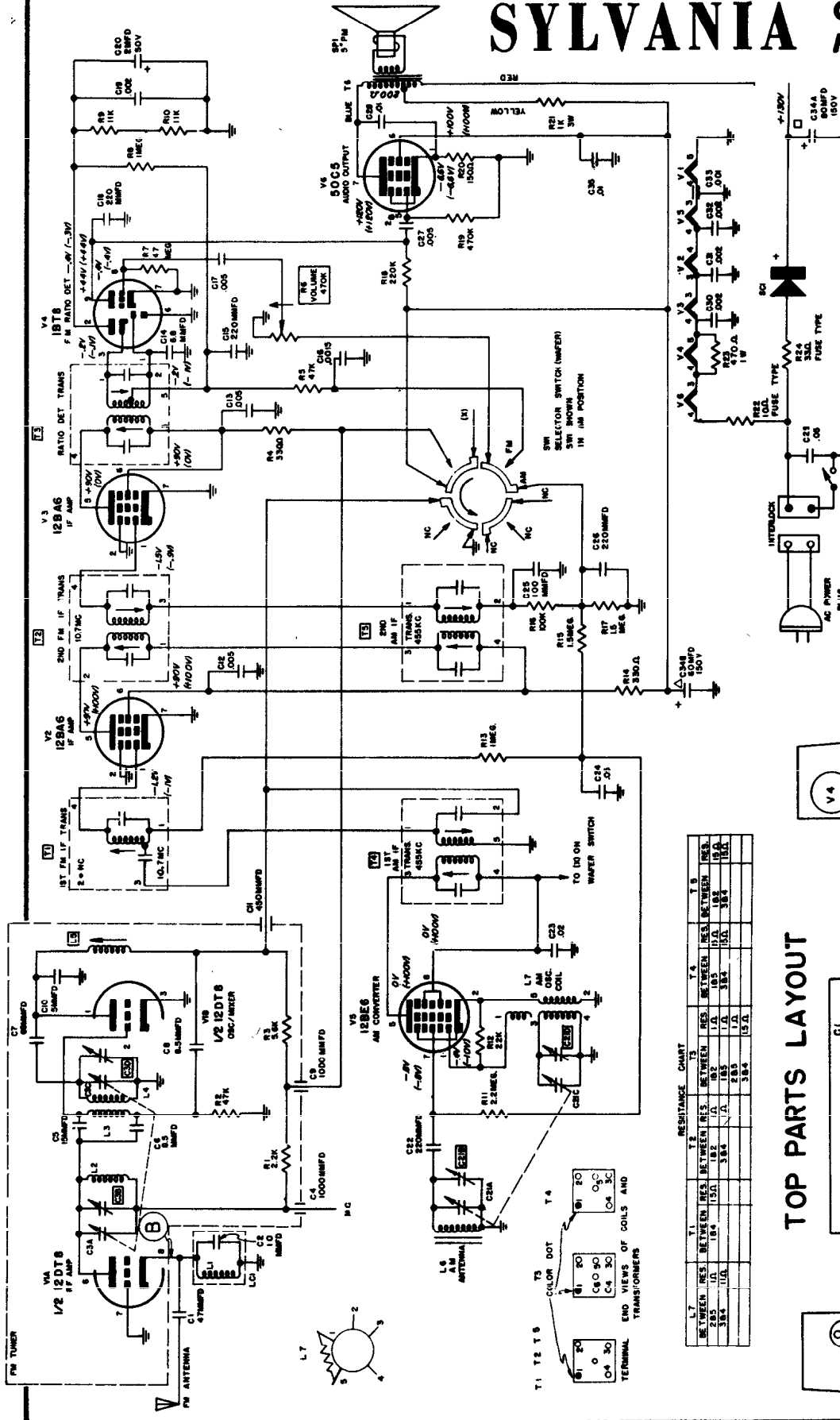

VOLTAGES SHOWN ARE AVERAGE READINGS MEASURED TO CHASSIS WITH NO SIGNAL INPUT. VARIATIONS MAY BE NOTED DUE TO NORMAL PRODUCTION TOLERANCES. VOLTAGE READINGS IN BRACKETS TAKEN WITH SELECTOR SWITCH IN THE AM POSITION. VOLTAGE READINGS WITHOUT BRACKETS TAKEN WITH SELECTOR SWITCH IN THE FM POSITION. RESISTANCES MEASURED WITH COMPONENTS IN THE CIRCUIT. CAPACITANCE IN MICROFARADS UNLESS OTHERWISE SPECIFIED. \perp DESIGNATES CHASSIS GROUND.

RESISTANCE CHART

T1	T2	T3	T4	T5
BETWEEN RES. BETWEEN RES. BETWEEN RES. BETWEEN RES. BETWEEN RES.	1.0	1.0	1.0	1.0
2.0	1.0	1.0	1.0	1.0
3.0	1.0	1.0	1.0	1.0
4.0	1.0	1.0	1.0	1.0
5.0	1.0	1.0	1.0	1.0
6.0	1.0	1.0	1.0	1.0
7.0	1.0	1.0	1.0	1.0
8.0	1.0	1.0	1.0	1.0
9.0	1.0	1.0	1.0	1.0
10.0	1.0	1.0	1.0	1.0

TOP PARTS LAYOUT

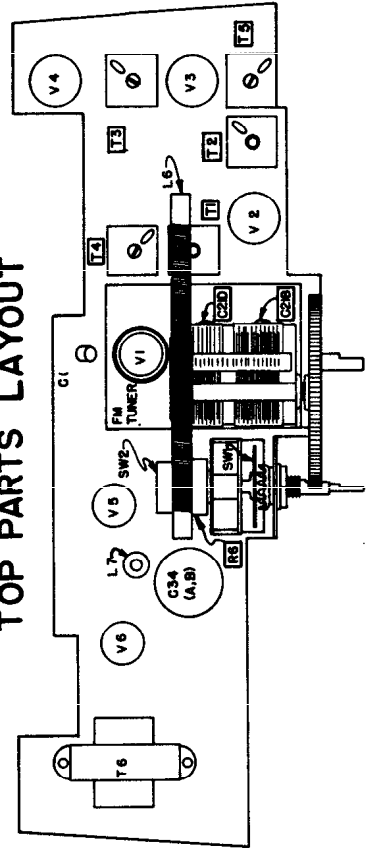

Sylvania

CHASSIS: 679-1
MODELS: 7K10, 7K11 SERIES

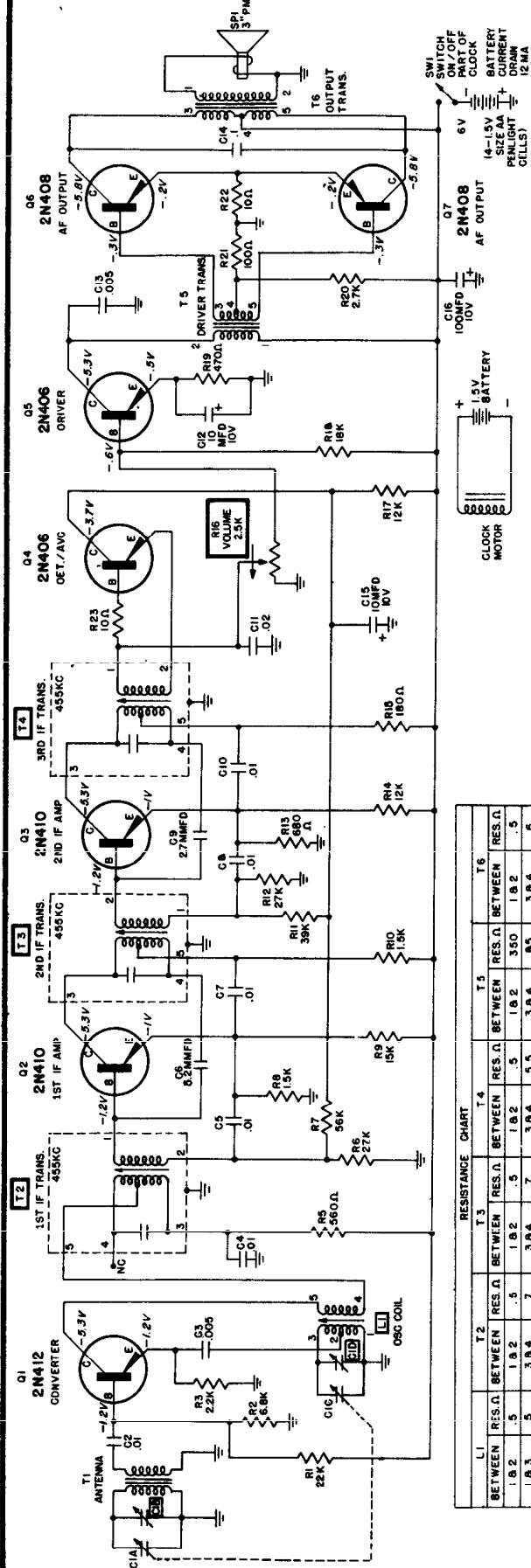

CHASSIS REMOVAL

1. Remove volume and station selector knobs by pulling straight outward.
2. Press the right side of case to separate back cover from front of case. Remove back being careful to pass time set knob thru hole in back cover.
3. Remove two (2) screws securing clock battery holder to speaker. Remove holder as far as leads permit.
4. Remove two (2) screws (located on the bottom of case) which secures radio battery holder to case. Remove holder as far as leads permit.
5. Remove three (3) screws and one (1) nut securing corners of chassis to case.
6. Lift chassis from case as far as leads permit.
7. To replace chassis reverse the above procedure making certain all insulating washers removed are replaced.

NOTE: Do not operate receiver with speaker disconnected.

RESISTANCE CHART

	T2	T3	T4	T5	T6
BETWEEN	RES. Ω	BETWEEN	RES. Ω	BETWEEN	RES. Ω
	RES. Ω		RES. Ω		RES. Ω
1 & 2	5	1.82	.5	1.82	350
2 & 3	5	3.84	7	3.84	1.82
3 & 4	5	3.84	5.5	3.84	6
4 & 5	5	3.85	2.5	3.85	1.40
5 & 6	5	4.85	1.5	4.85	55
					4.85

RESISTANCE VALUES TAKEN WITH COMPONENTS IN THE CIRCUIT.
ALL CAPACITORS IN MICROFARADS UNLESS OTHERWISE SPECIFIED.

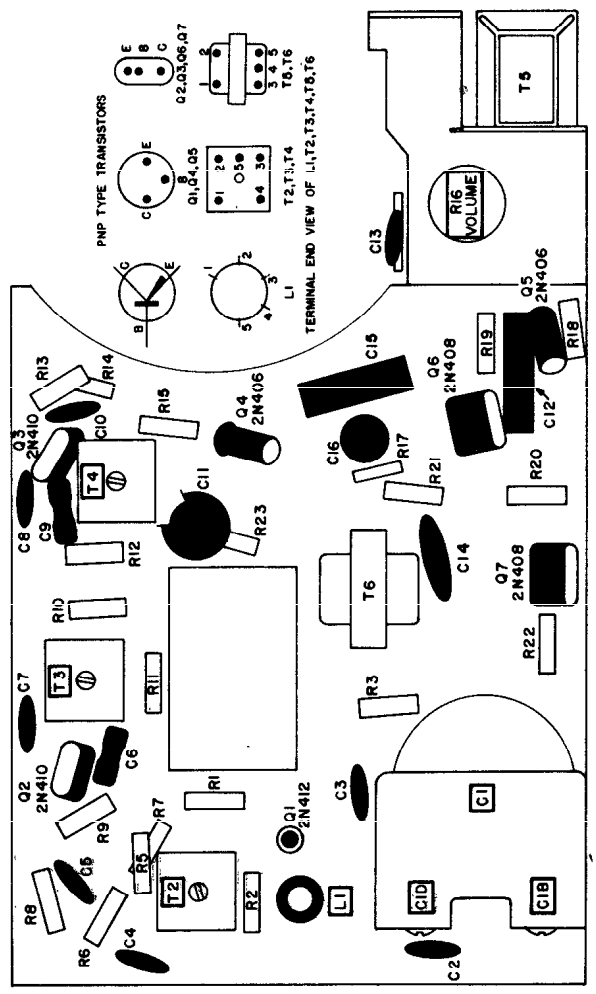

SYLVANIA

CHASSIS: 680-1
MODELS: 45P19

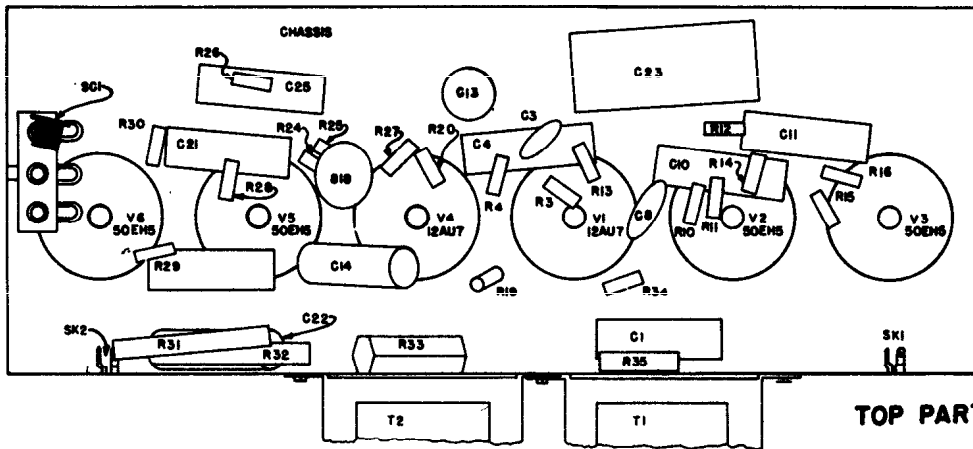
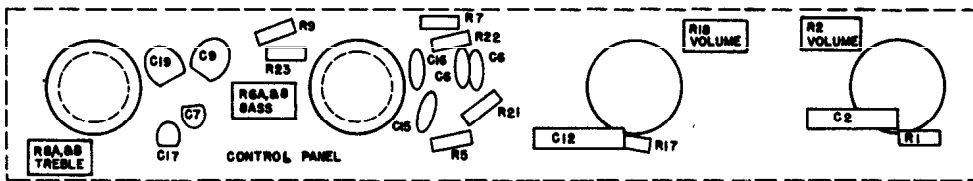
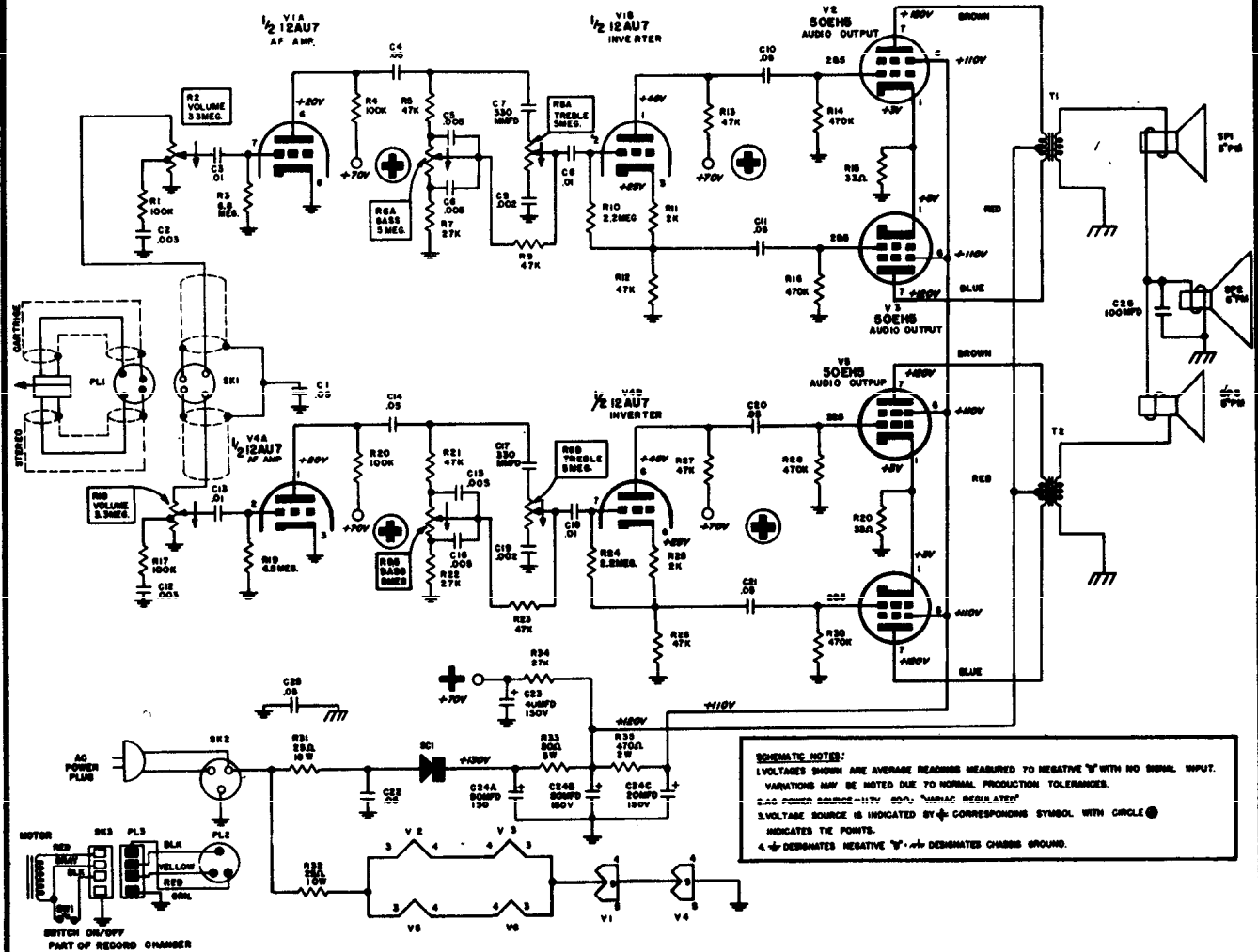

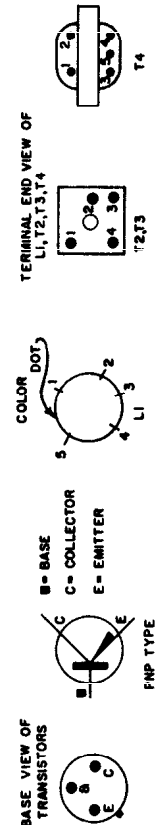
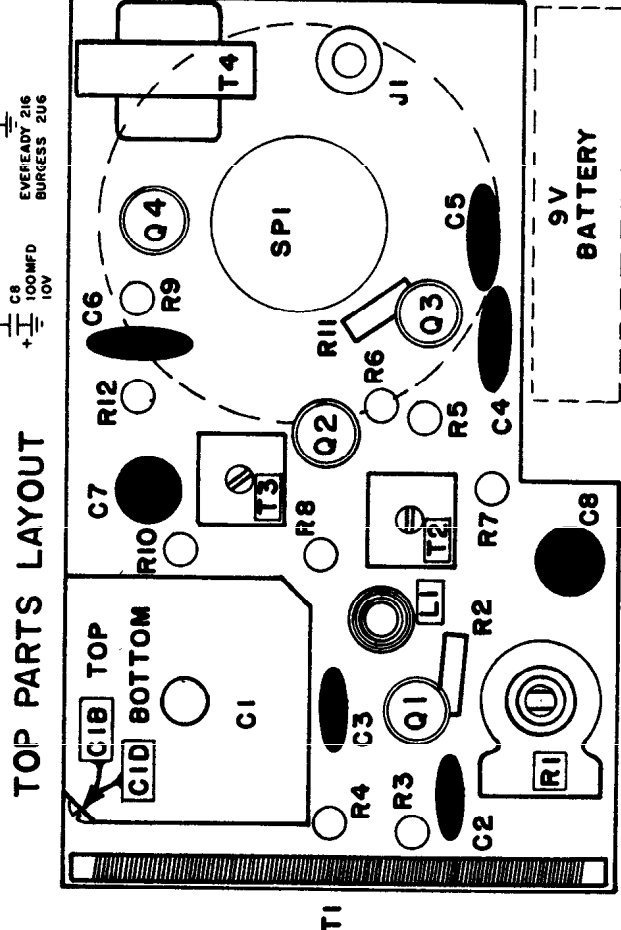
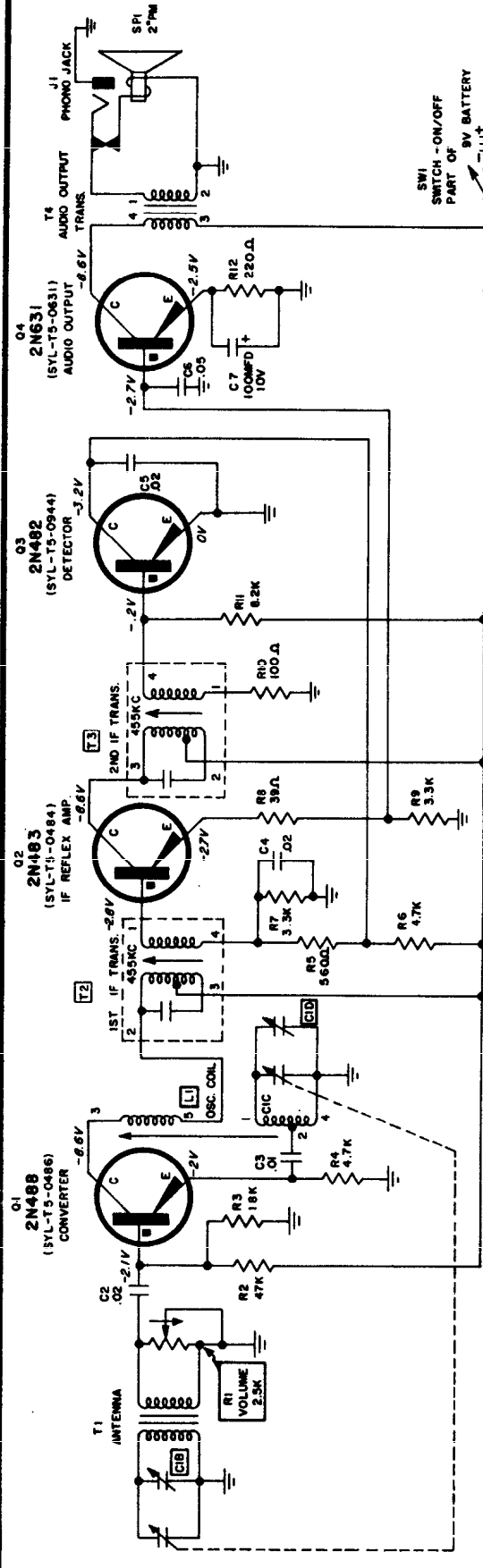

RESISTANCE CHART

L1	T2	T3	T4
BETWEEN RES.	BETWEEN RES.	BETWEEN RES.	BETWEEN RES.
1.8 2	8 Ω	1.8 4	1 Ω
1.8 4	1.8 4	1.8 4	1.8 2
1.8 4	2.8 3	5 Ω	2 Ω
2.8 4	.5 Ω		40 Ω
3.8 5	1 Ω		

SCHMATIC NOTES

1. VOLTAGES MEASURED TO CHASSIS GROUND, WITH RECEIVER NOT TUNED TO ANY SPECIFIC STATION.
2. BATTERY VOLTAGE WITH RECEIVER OPERATING 9 VOLTS.
3. VOLTAGES SHOWN ARE AVERAGE READINGS. VARIATIONS MAY BE NOTED DUE TO NORMAL PRODUCTION TOLERANCE.
4. COIL AND TRANSFORMER RESISTANCE ARE TAKEN WITH COMPONENTS CONNECTED IN THE CIRCUIT.
5. ALL CAPACITORS IN MICROFARADS UNLESS OTHERWISE SPECIFIED.
6. INTERMEDIATE FREQUENCY (IF), 455KC.
7. ⊕ DESIGNATES CHASSIS GROUND.

SYLVANIA
CHASSIS: 690-1
MODELS: 4P05, 4P06

VOLUME R-21, MOST-OFTEN-NEEDED 1961 RADIO SERVICING INFORMATION

TRAV-LER Models 60C300, 60C301, 60C302, 60C303, 60C320, 60C321, 60C322, 60C323

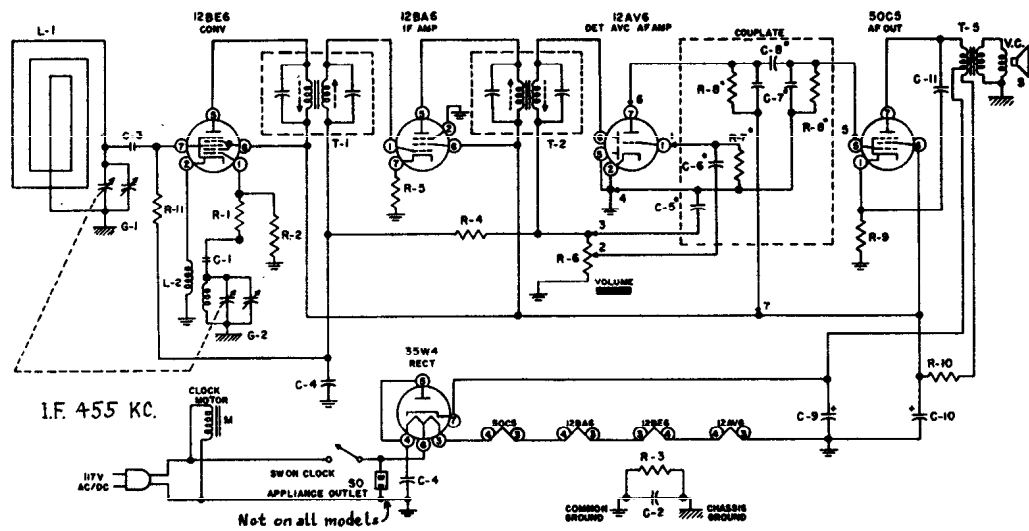

PART NO.	DESCRIPTION	PART NO.	DESCRIPTION	PART NO.	DESCRIPTION
IR-4	R-1 47Ω RESISTOR 1/2W. 20%	CC-12	C-1 47 MMFD CERAMIC CONDENSER	SPK-55X	S 4\"/>
IR-45	R-2 22MΩ RESISTOR 1/2W. 10%	PC-8	C-2 1 MFD. CONDENSER 400 V.	V.C.	T-3 VOICE COIL
IR-20	R-3 220MΩ RESISTOR 1/2W. 20%	CC-33	C-3 220 MMFD. 350V. 20% CER COND.	L-1	L-1 LOOP ANTENNA
IR-23	R-4 3.3MEG. RESISTOR 1/2W. 20%	PC-5	C-4 .05 MFD. CONDENSER 400 V.	L-2	L-2 OSC. COIL
IR-155	R-5 120Ω RESISTOR 1/2W. 10%	MC-19	C-5 220 MMFD.	SO	SO-34 APPLIANCE OUTLET SOCKET
MC-101	R-6 1MEG. VOLUME CONTROL	C-6	C-6 .002 MFD.	CK-7	M ELECTRIC CLOCK
MC-19	R-7 6.8MEG.	C-7	C-7 250 MMFD.		
	R-8 470MΩ.	C-8	C-8 .005 MFD.		
IR-98	R-9 150Ω RESISTOR 1/2W. 10%	EC-68	C-9 70 MFD. 150 W.V.D.C. ELECTROLYTIC		
IR-42	R-10 1000Ω RESISTOR 1 W. 10%	C-10	C-10 40 MFD.		
IR-12	R-11 1MEG. RESISTOR 1/2W. 20%	PC-47	C-11 .02 MFD. CONDENSER 400V.		
LI-19	T-1 INPUT I.F. TRANSFORMER	GC-24	G-1 TUNING CONDENSER		
	T-2 OUTPUT I.F. TRANSFORMER		G-2		

TRAV-LER RADIO

MODEL-1130

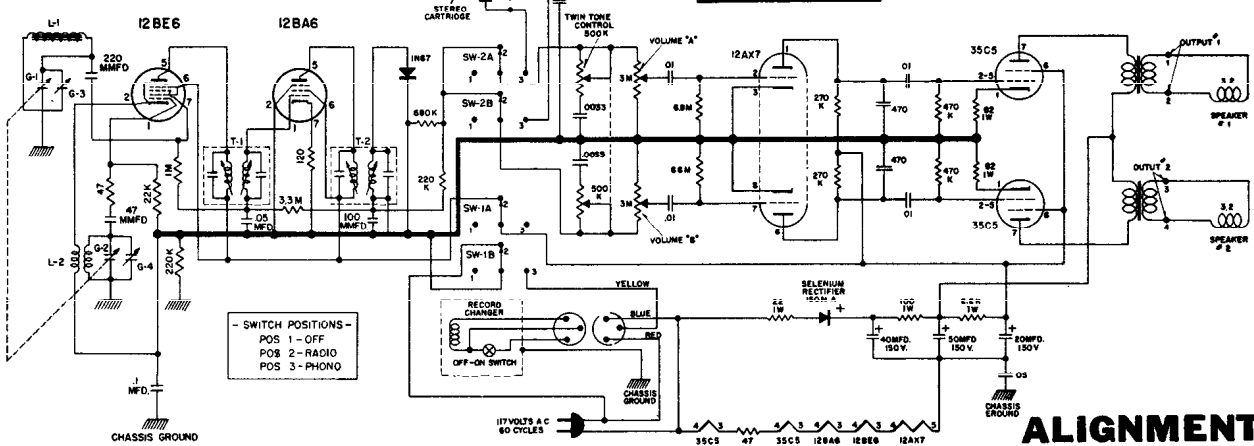

ALIGNMENT

FIRST STEP: Connect the hot lead from the generator to the ANT. section of the gang condenser through a .1 MFD. condenser. The ground lead from the generator must be connected to "B" minus under the chassis. Turn the gang condenser to complete minimum capacity. Set the generator to 455 KC. Adjust the movable iron cores in the IF cans.

SECOND STEP: With the leads from the generator still connected as in IF alignment, adjust the generator to 1610 KC. Make sure that the gang condenser is turned to complete minimum capacity. Adjust the generator to 1610 KC. and adjust the oscillator trimmer of the receiver until the signal is tuned in. Next, turn the gang condenser to complete maximum capacity. Adjust the generator to 540 KC., then adjust the iron core in the end of the oscillator coil until the signal is tuned in.

THIRD STEP: Remove the generator leads from the gang condenser and the chassis. Loosely couple the generator to the antenna by laying the hot generator lead near the antenna rod. Set the generator at 1400 KC. and tune in the 1400 KC. signal on the receiver. Adjust the ANT. trimmer until a maximum signal is noted on the output meter.

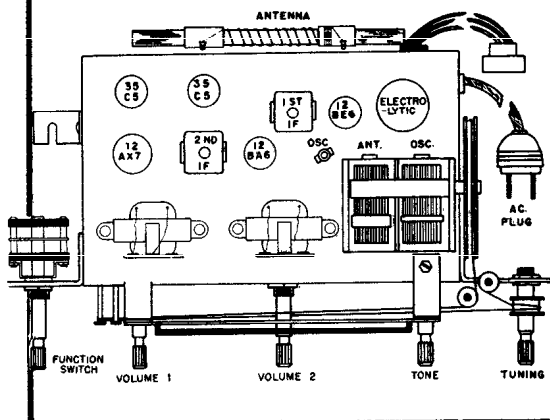

MODEL 1050-1A FONOGRAF

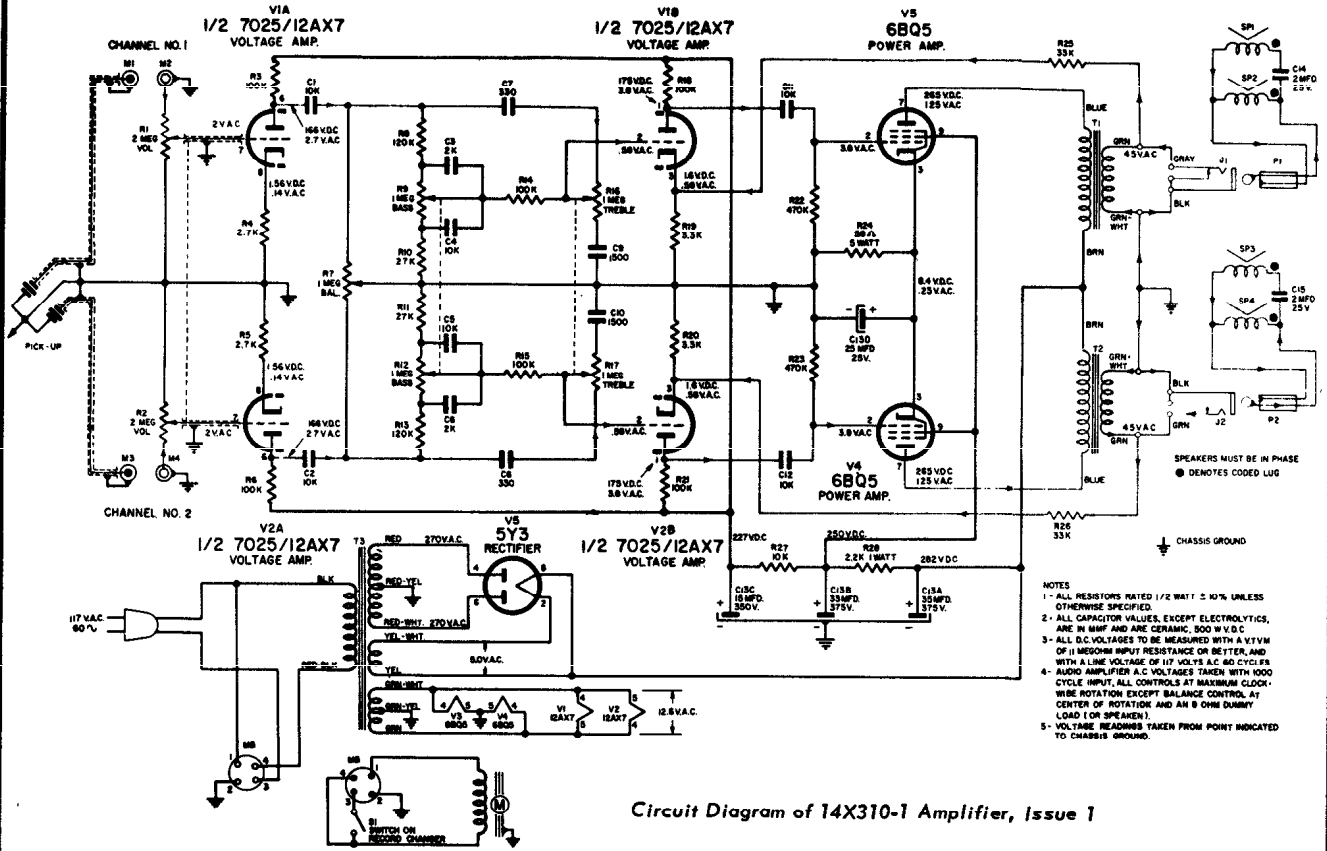

WEBCOR MODEL 1172-1 FONOGRAF

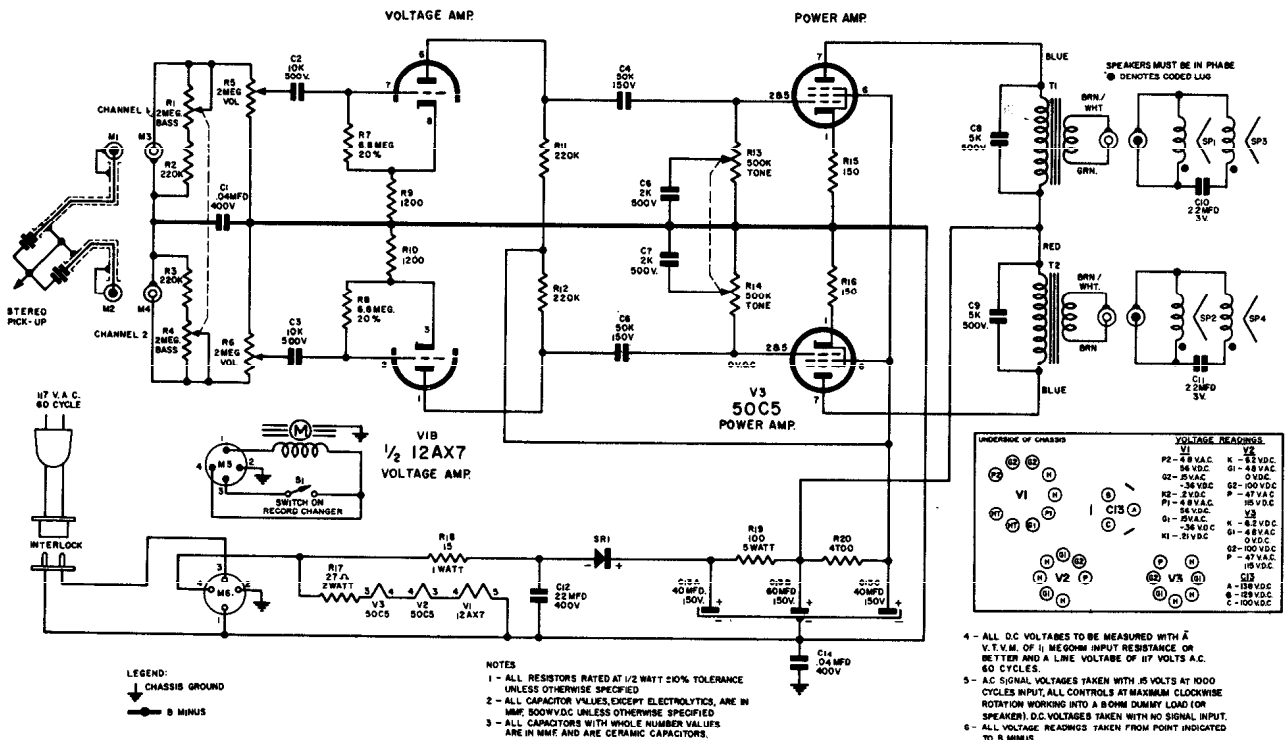

WEBCOR Amplifier 14X331, used in Models BC1055, MC1055, WC1055

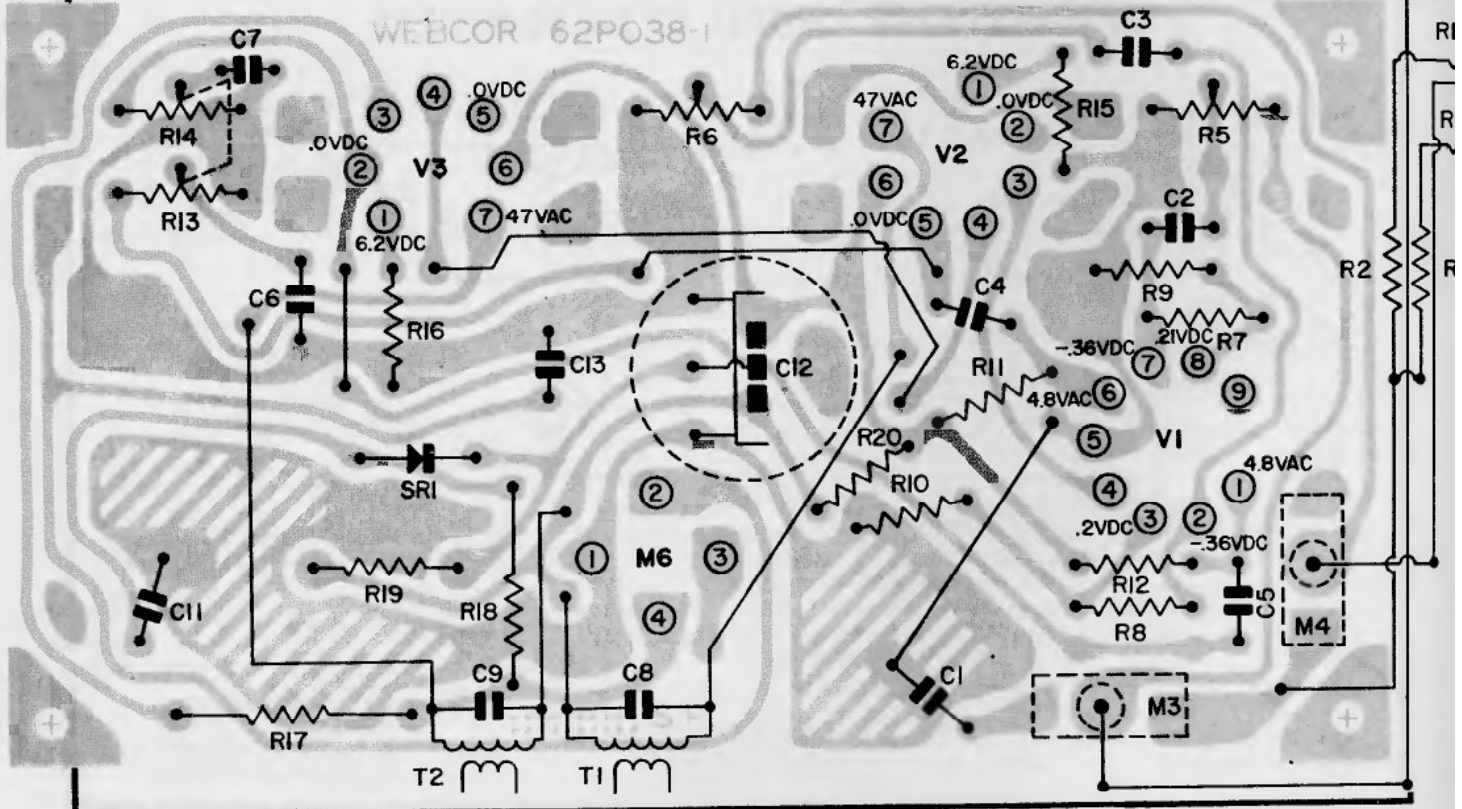
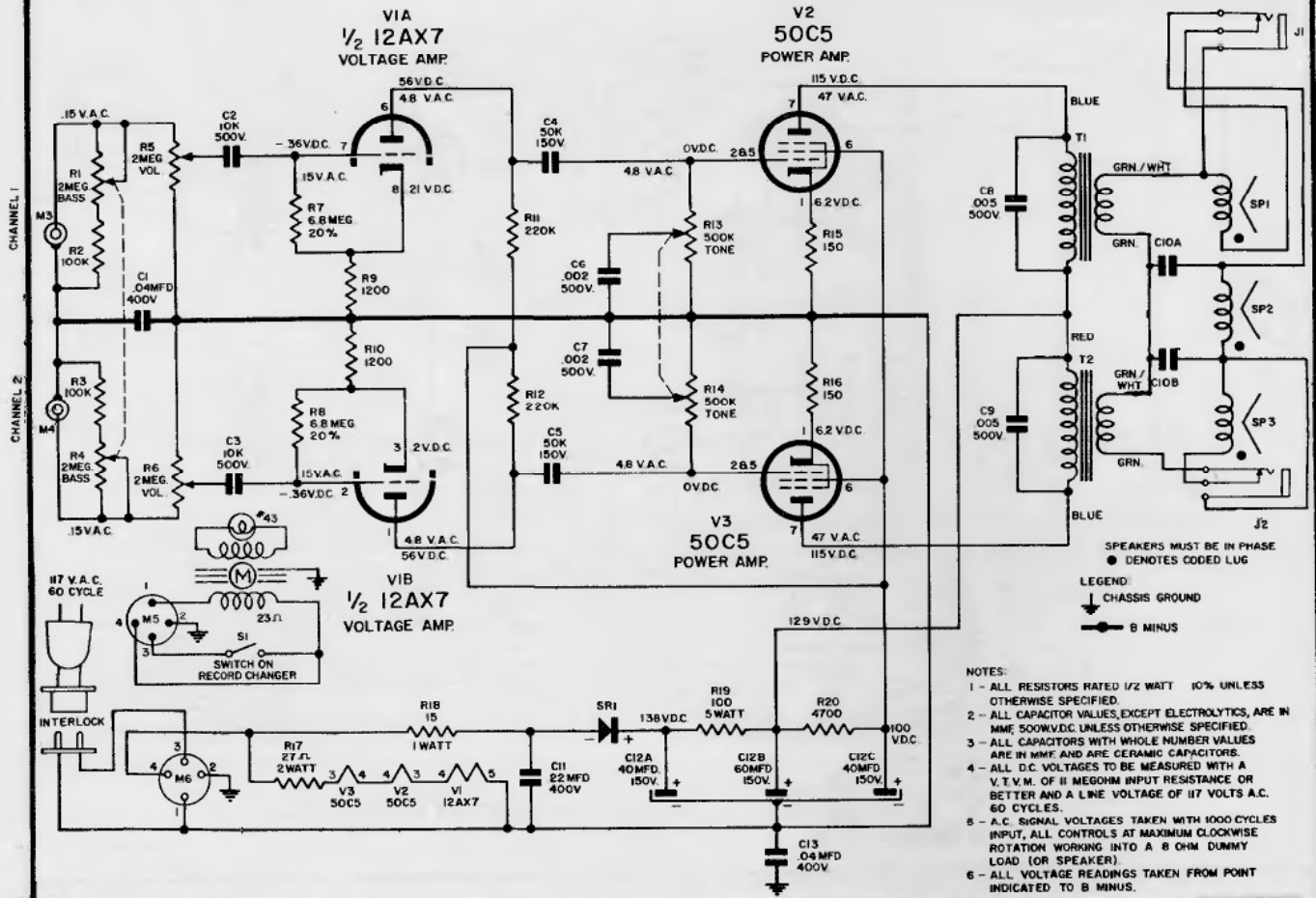

WESTERN AUTO Model DC2083B, Exact Service Material.
Model DC2173A is the same electrically, while additional
Models DC2082B and DC2172A are very similar electrically
 but do not use clock-switching network.

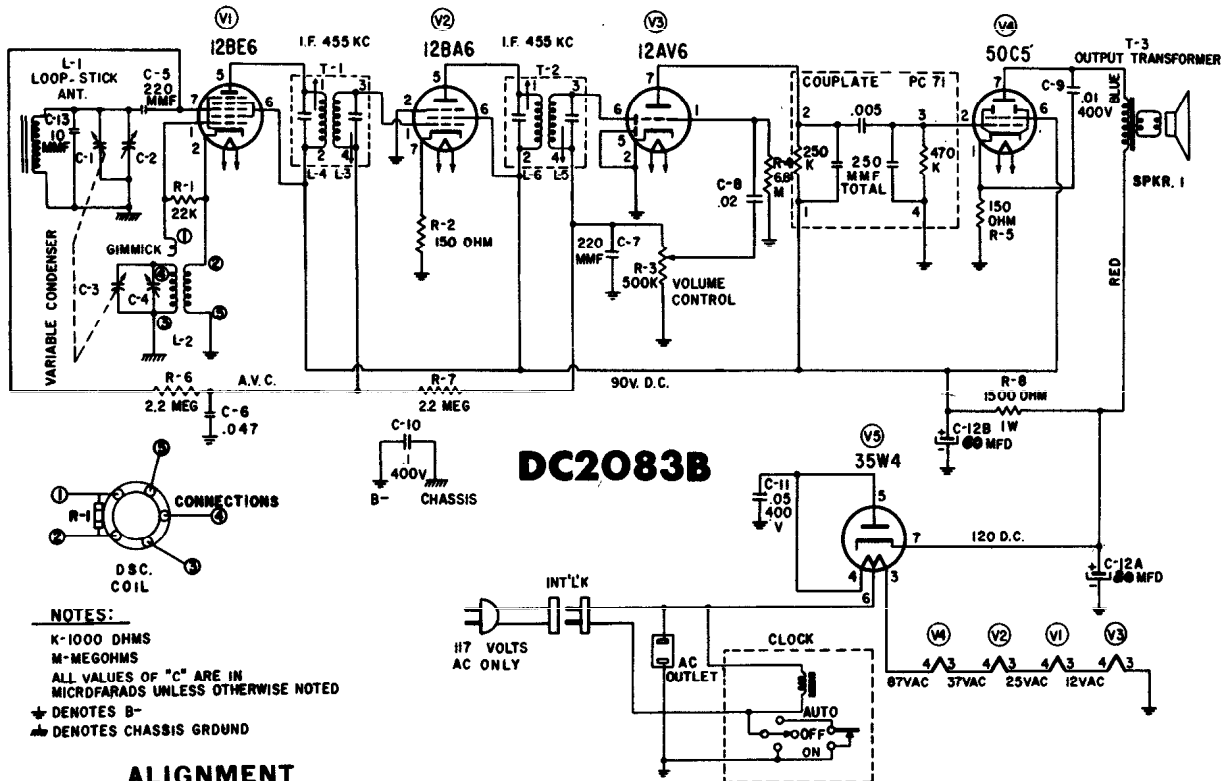

NOTES:
 K-1000 DHMS
 M-MEGOHMS
 ALL VALUES OF "C" ARE IN MICROFARADS UNLESS OTHERWISE NOTED
 † DENOTES B-
 ‡ DENOTES CHASSIS GROUND

ALIGNMENT

Equipment required: Modulated RF signal generator; output meter; insulated screwdriver, two .1 mfd 600 volt condensers. To insure proper alignment, a radiated signal will be required during part of the alignment procedure. To radiate a signal, connect a loop of about 6 inches in diameter (two or three turns of #18 or #22 wire) across the output of the signal generator, and place this loop parallel to the loop of the receiver to be aligned, at a distance of about 10 or 12 inches. Connect the output meter and signal generator as follows:

Output meter: Connect across the speaker voice coil and turn the volume control to maximum (extreme clockwise position). Signal generator: When the generator is not used to radiate a signal, connect the low side to B--through a .1 mfd condenser, clip the high side through a .1 mfd 600 volt condenser to the point at which signal injection is required, and keep the output as low as possible. Proceed in the sequence shown in the alignment chart.

The chassis is attached to the front panel and must be removed from the cabinet before alignment can be performed. To remove the front panel from the cabinet remove the two screws on back of cabinet.

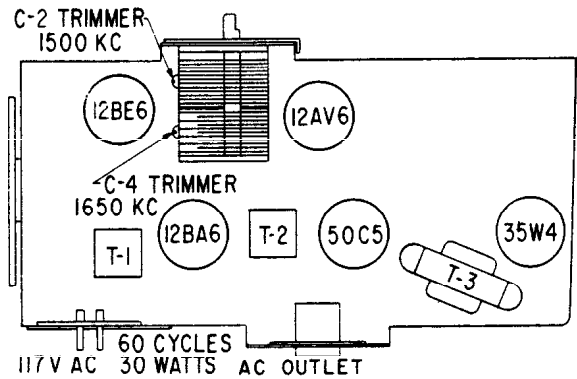

ALIGNMENT PROCEDURE CHART

Step	Connect High Side of Signal Generator To--	Set Signal Generator To--	Turn Receiver Dial To--	Adjust The Following for Maximum Output (Keep Signal From Signal Generator As Low As Possible)
1	Antenna Section Tuning Condenser in Series with .1MFD. Cond.	455 KC.	Full Counter Clockwise (Condenser Plates Fully Open)	Top and Bottom T2 and T1 (I.F. Transformers)
2		1650 KC.		C4 (Oscillator Trimmer)
3	Use Radiated Signal	1500 KC.	Maximum Signal Approx. 1500 KC.	C2 Antenna Trimmer)
4		Repeat Steps 2 and 3		

WESTERN AUTO Model DC3160

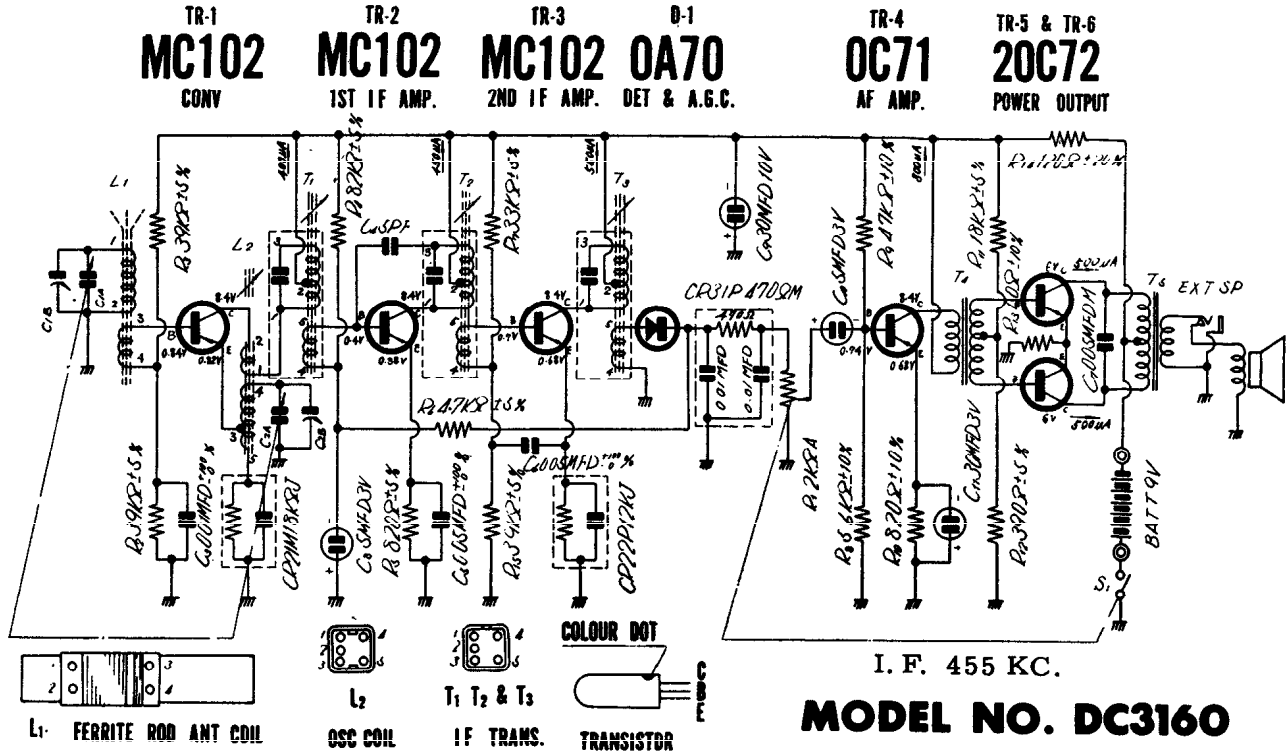

WESTERN AUTO Model DC3085C

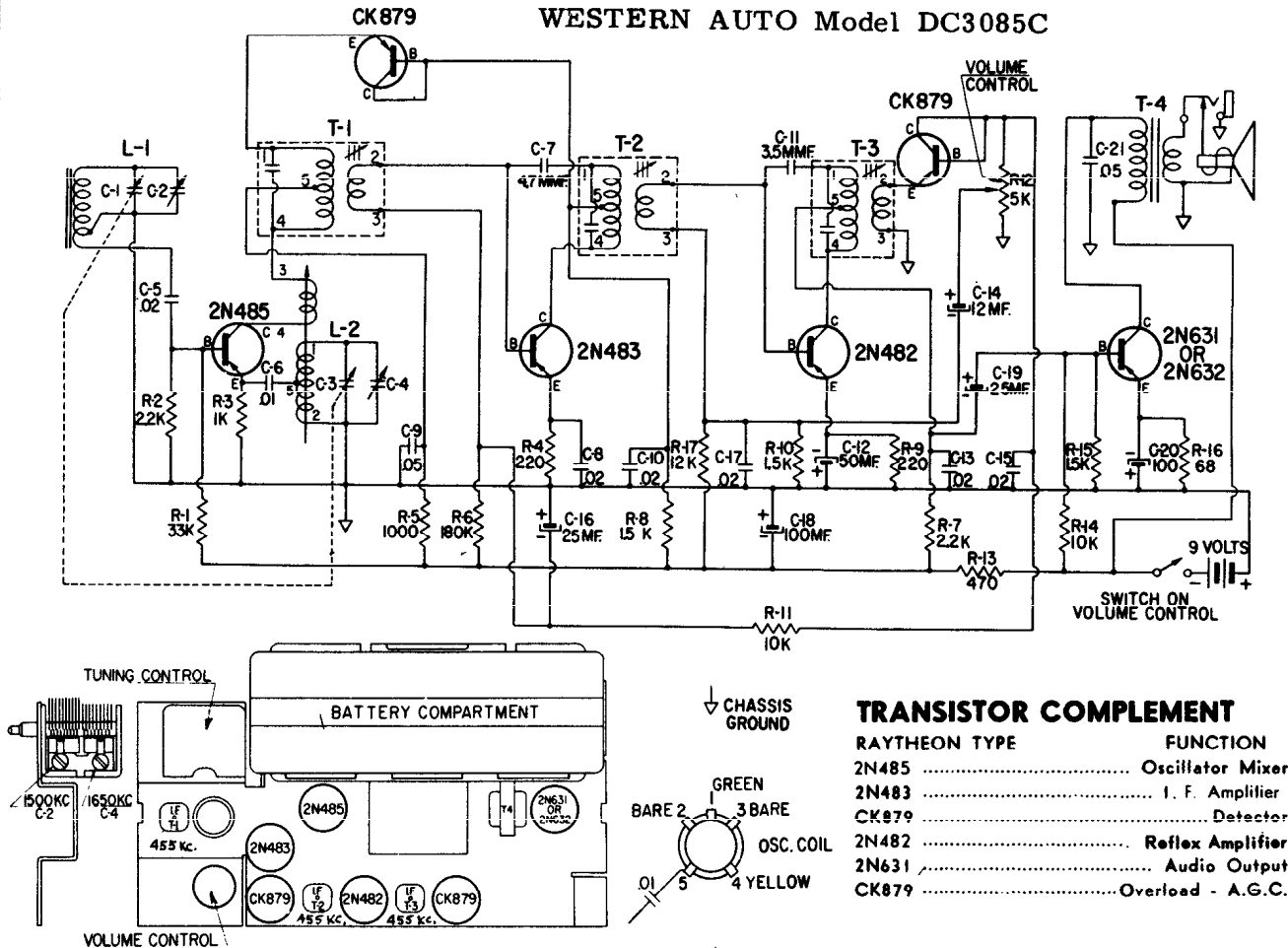

VOLUME R-21, MOST-OFTEN-NEEDED 1961 RADIO SERVICING INFORMATION

WESTINGHOUSE Chassis V-2395-3, Models H-753L5, H-755L5.

Chassis V-2395-2, Models H-748T5, H-749T5, H-750T5, differ from V-2395-3 in audio circuit and omit clock and its circuit.

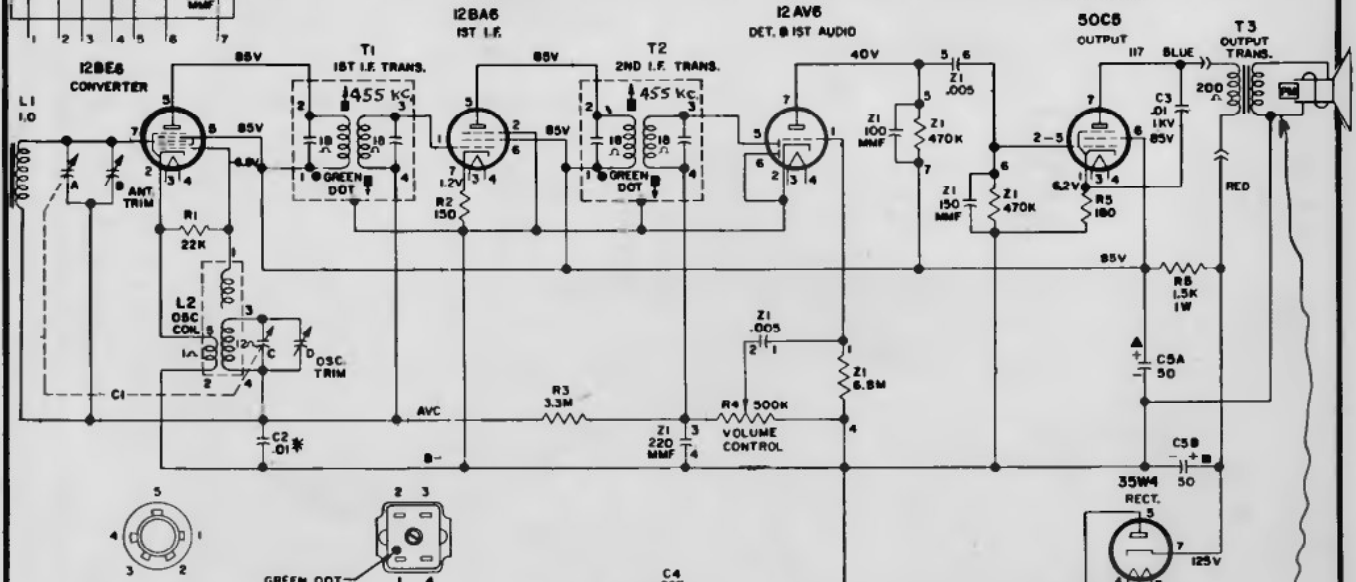
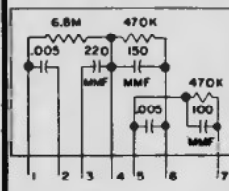
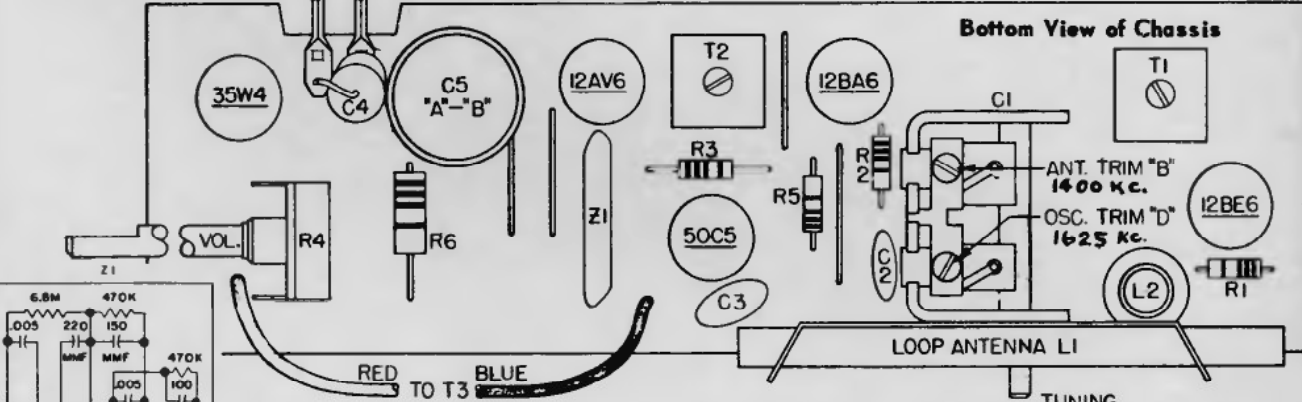
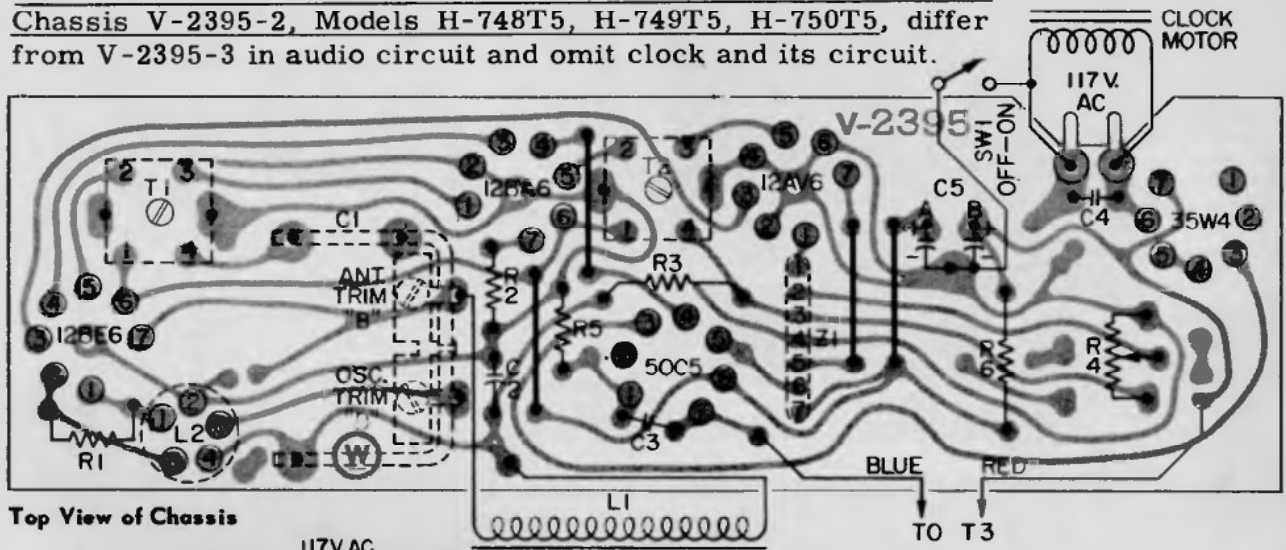

- NOTES**
1. ALL VOLTAGES MEASURED FROM COMMON NEGATIVE USING A V.T.V.M., VOLUME CONTROL AT MINIMUM, TUNING CAPACITOR AT MAXIMUM LINE VOLTAGE SET AT 117 V.A.C. READINGS SHOULD BE AS SHOWN $\pm 20\%$.
 2. ALL CAPACITANCE VALUES IN MFD. AND ALL RESISTANCE VALUES IN OHMS UNLESS OTHERWISE SPECIFIED.

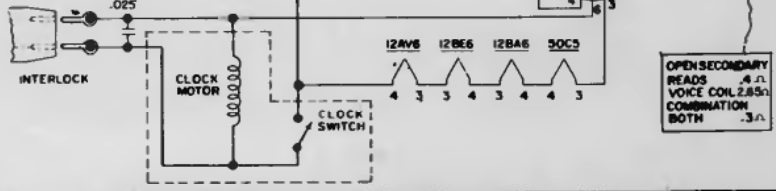

OPEN SECONDARY READS .6 Ω VOICE COIL 2.85 Ω COMBINATION BOTH .3 Ω

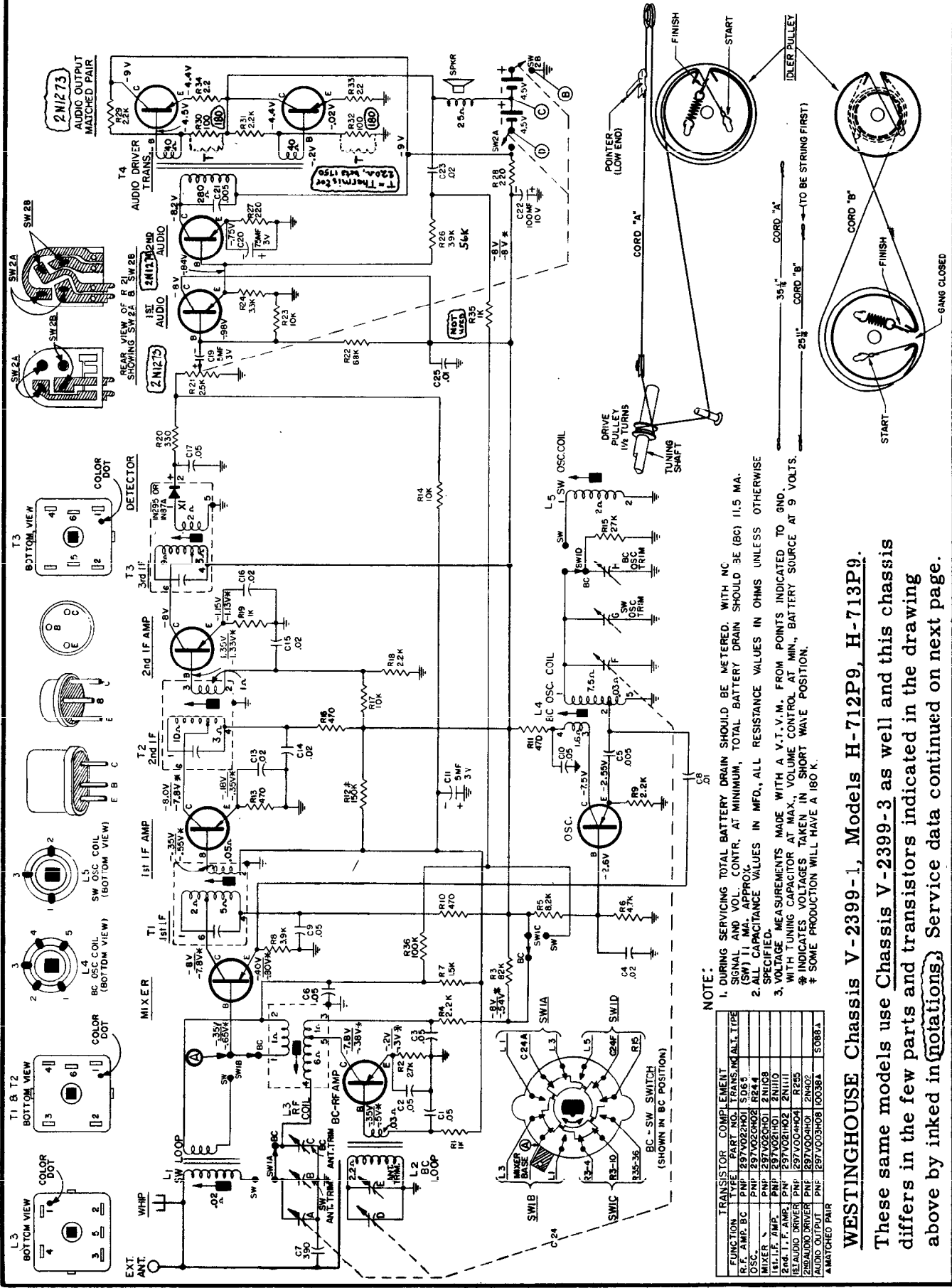

NOTE:

- DURING SERVICING TOTAL BATTERY DRAIN SHOULD BE METERED. WITH NC (SW) 11 MA. APPROX.
- ALL CAPACITANCE VALUES IN MFD., ALL RESISTANCE VALUES IN OHMS UNLESS OTHERWISE SPECIFIED.
- VOLTAGE MEASUREMENTS MADE WITH A V.T.V.M. FROM POINTS INDICATED TO GND. WITH TUNING CAPACITOR AT MAX., VOLUME CONTROL AT MIN., BATTERY SOURCE AT 9 VOLTS. † INDICATES VOLTAGES TAKEN IN SHORT WAVE POSITION.

† SOME PRODUCTION LINES HAVE A 180 K.

WESTINGHOUSE Chassis V-2399-1, Models H-712P9, H-713P9.

These same models use Chassis V-2399-3 as well and this chassis differs in the few parts and transistors indicated in the drawing above by inked in notations. Service data continued on next page.

WESTINGHOUSE

Chassis V-2399-1
 Models H-712P9, H-713P9
 (Continued from preceding page.)

Frequency Range
 Broadcast 540 to 1600KC
 Short Wave 2.4 to 6.5MC
 Intermediate Frequency 455KC

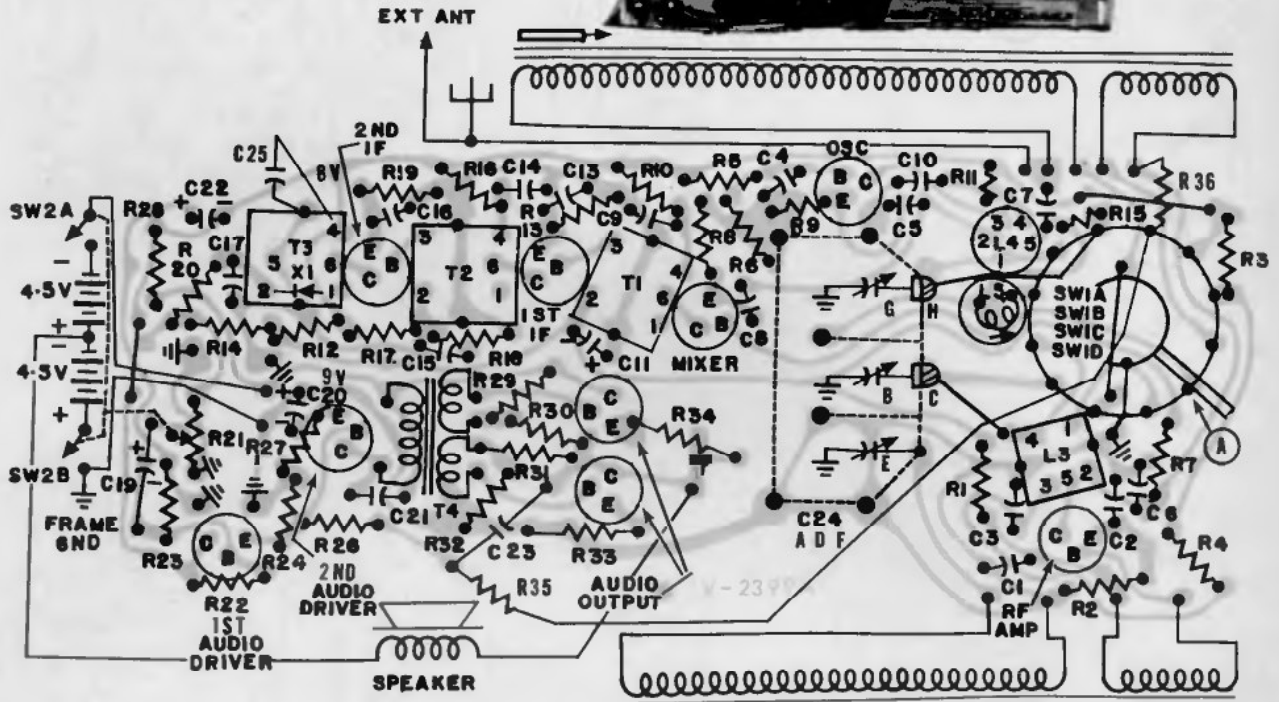
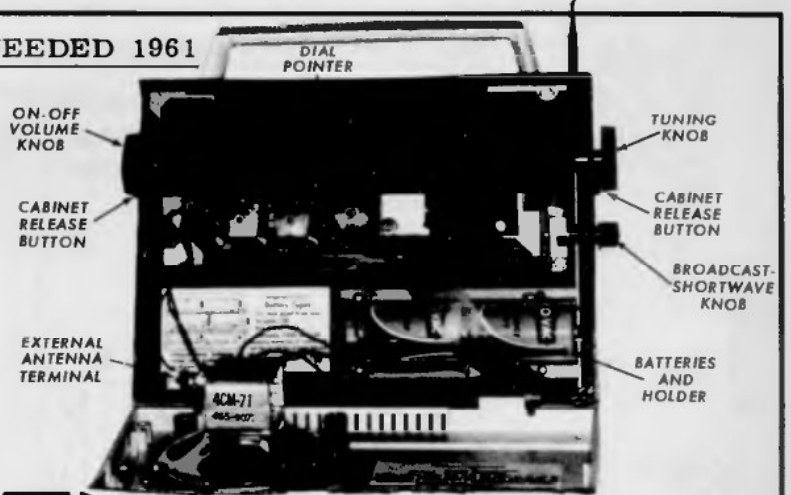

Bottom view of printed circuit chassis, showing components symbolically.

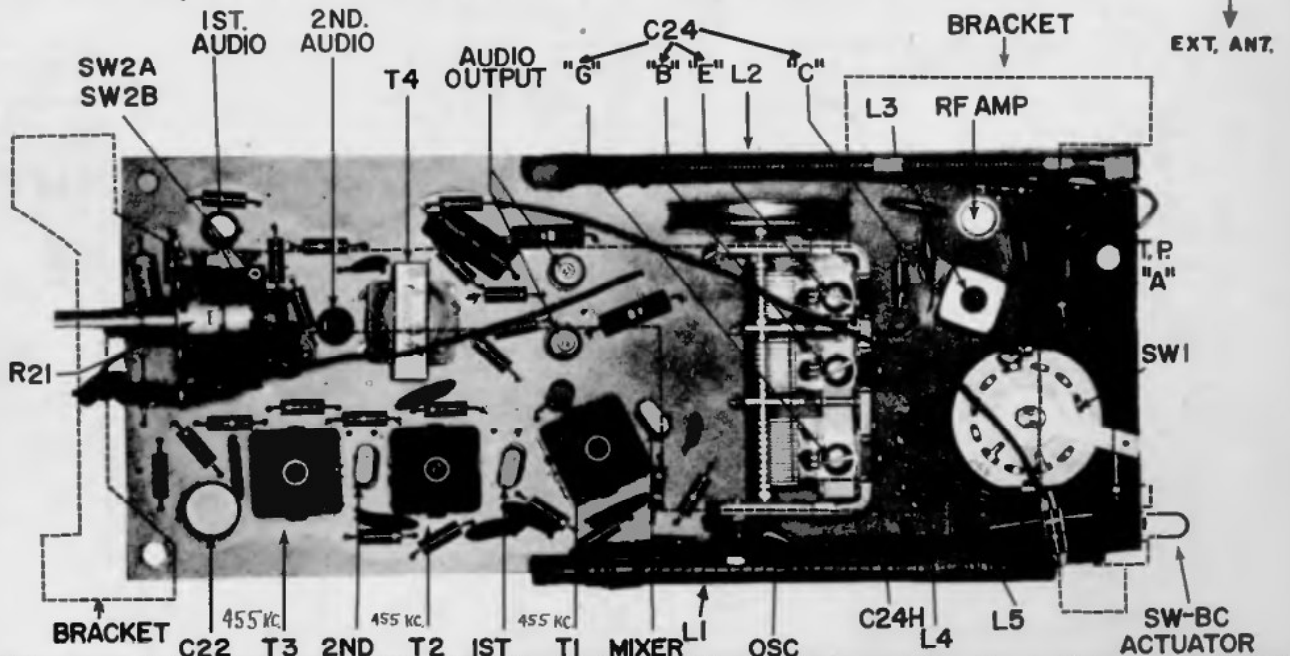

MOST-OFTEN-NEEDED 1961 RADIO SERVICING INFORMATION

**Westinghouse Chassis V-2397-4,
Models H-725P6A, H-726P6A,
H-727P6A, H-728P6A, H-771P6,
H-771P6GP, H-772P6, -GP,
H-773P6, and H-773P6GP.**

FUNCTION	TRANSISTOR TYPE	COMPLEMENT
CONVERTER	PNP 297V01HD	2M42
1st I.F. AMP	PNP 297V02HD	2M410
2nd I.F. AMP	PNP 297V02HD	2M410
AUDIO DRIVER	PNP 297V04HD	2M406
AUDIO OUTPUT	PNP 297V03HD	2M408

• MATCHED PAIR (SEE NOTES)

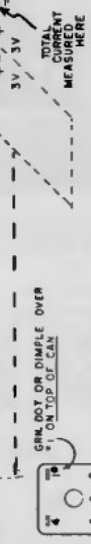
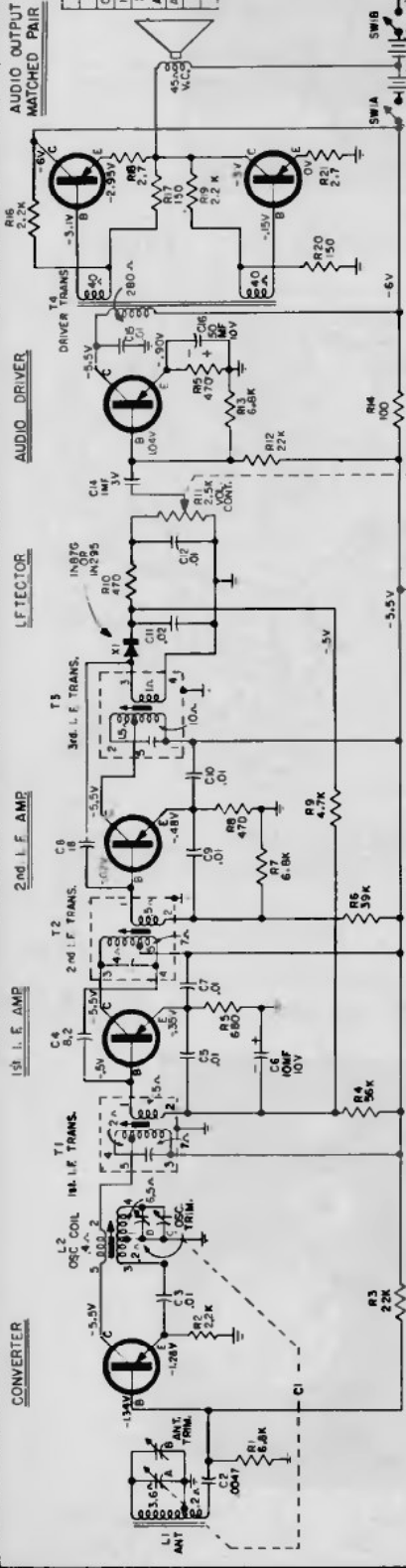

- NOTES:**
1. DURING SERVICING, TOTAL BATTERY CURRENT SHOULD BE METERED, WITH NO SIGNAL, AND VOLUME CONTROL AT MINIMUM. TOTAL BATTERY DRAIN SHOULD BE APPROX. 9 MA.
 2. VOLTAGE MEASUREMENTS MADE WITH A VTVM FROM POINTS INDICATED TO GROUND, WITH TUNING CAPACITOR AT MAXIMUM, VOLUME CONTROL AT MINIMUM & BATTERY SOURCE AT 6 VOLTS.
 3. ALL CAPACITORS LISTED ARE IN MICROFARADS UNLESS OTHERWISE SPECIFIED. ALL CAPACITORS GREATER THAN ONE ARE IN MMFD.
 - ANY TWO AUDIO OUTPUT TRANSISTORS WITH IDENTICAL COLOR CODE ON TOP CAN BE USED AS A MATCHED PAIR.

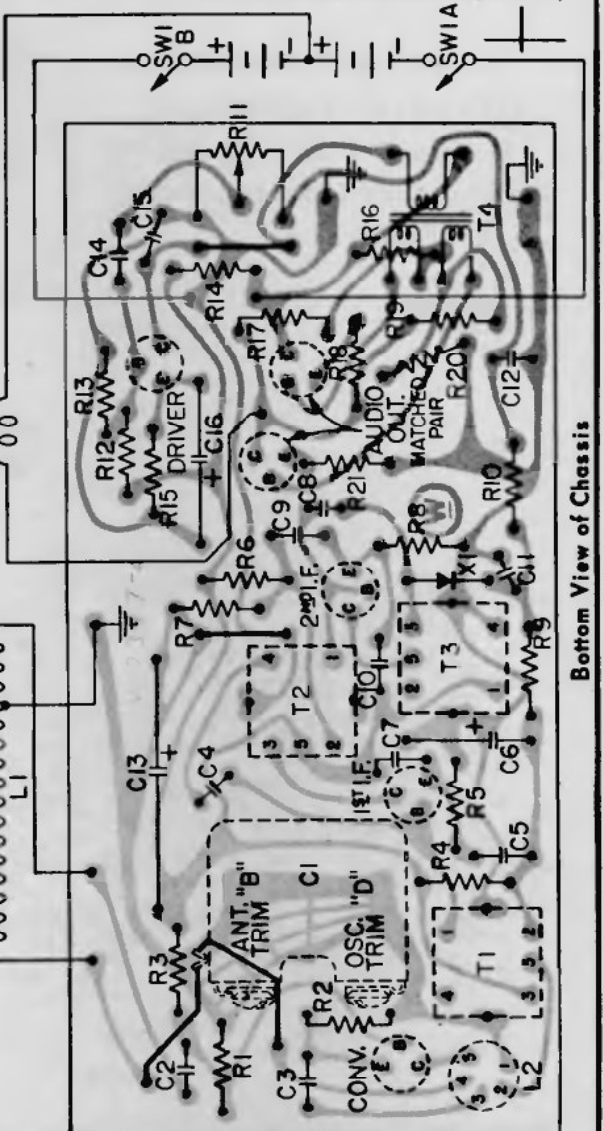
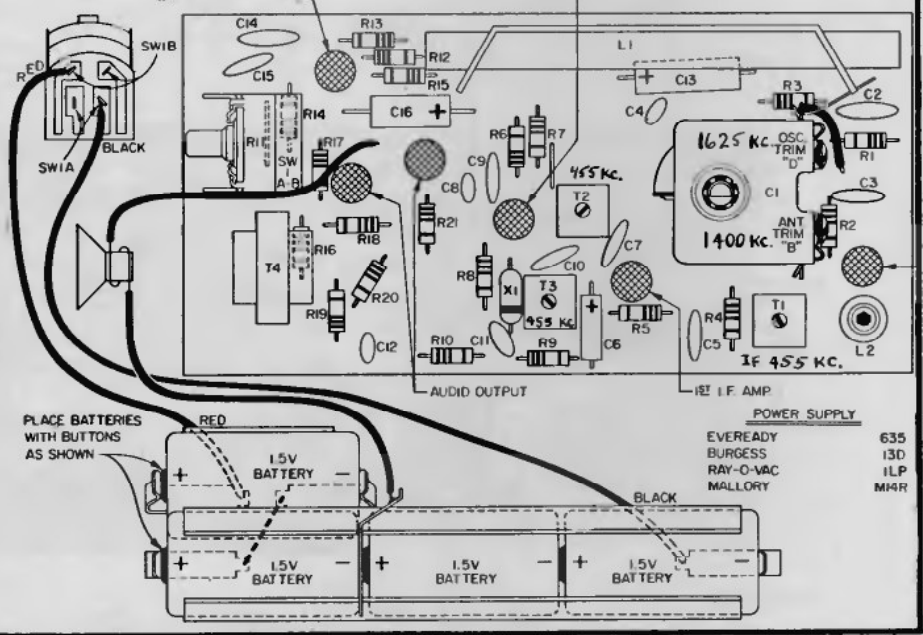

Bottom View of Chassis

Top View of Chassis

WESTINGHOUSE
Chassis V-2401-3,
Models H-718T5A,
H-719T5A, H-720T5A.

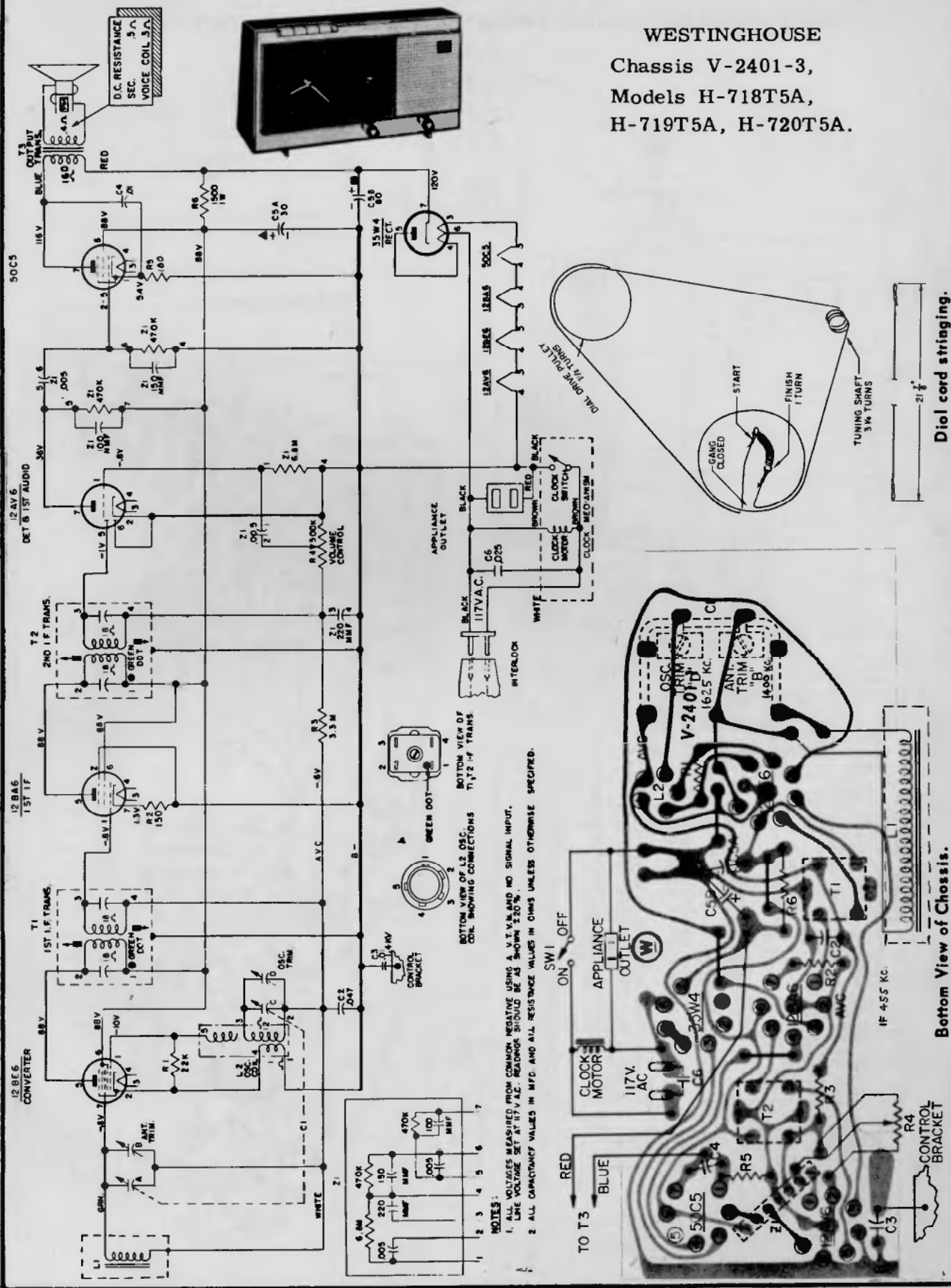

NOTES:
1. ALL VOLTAGES MEASURED FROM COMMON NEGATIVE USING A 1.5 V. B. AND NO SIGNAL INPUT.
2. ALL CAPACITANCE VALUES IN MFD. AND ALL RESISTANCE VALUES IN OHMS UNLESS OTHERWISE SPECIFIED.

WESTINGHOUSE Chassis V-2404-1, Models H-737P7, H-738P7

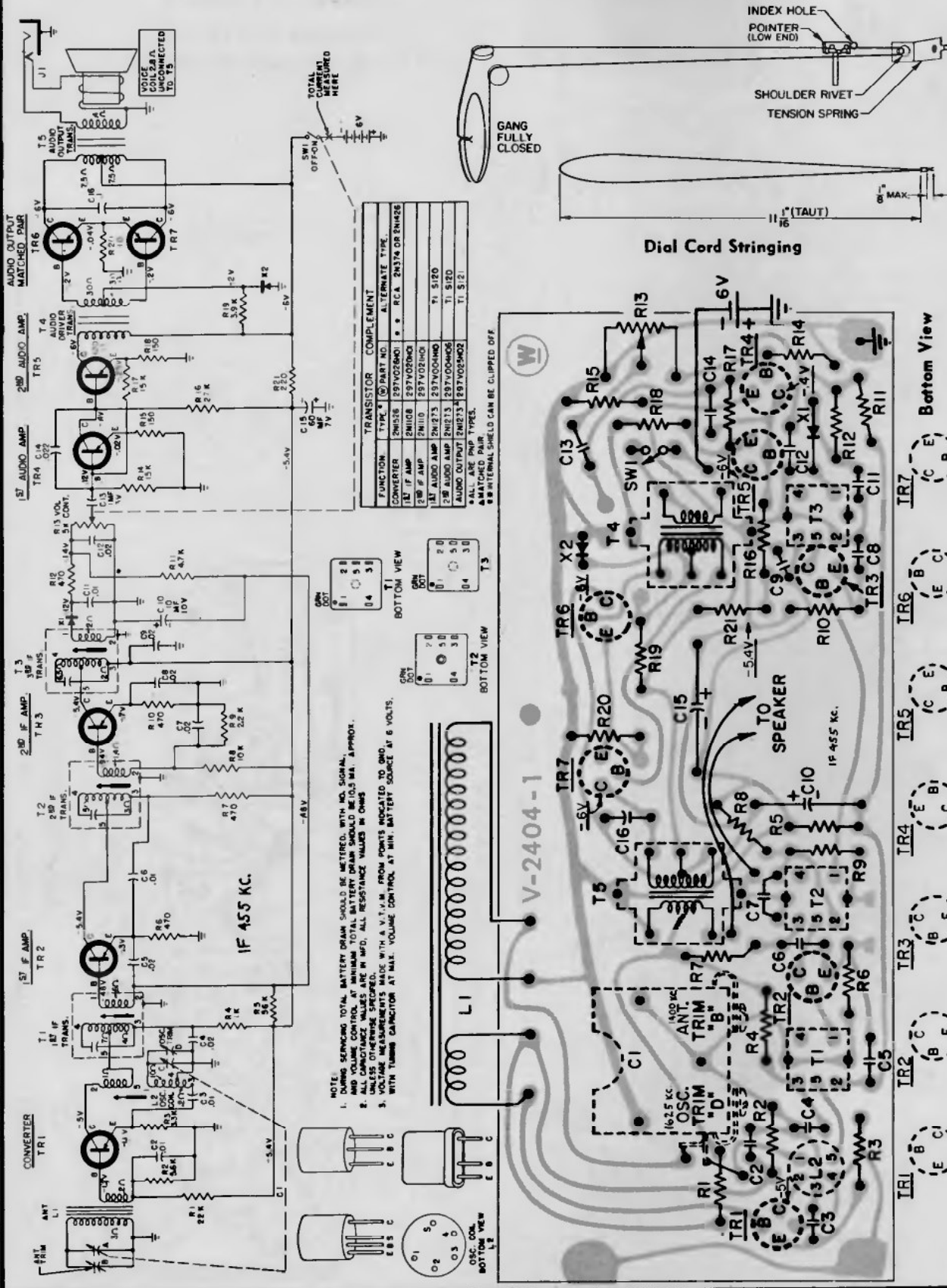

VOLUME R-21, MOST-OFTEN-NEEDED 1961 RADIO SERVICING INFORMATION

WESTINGHOUSE Chassis V-2410-1
Models H-756T5 and H-757T5

WESTINGHOUSE Chassis V-2410-1
Models H-756T5 and H-757T5

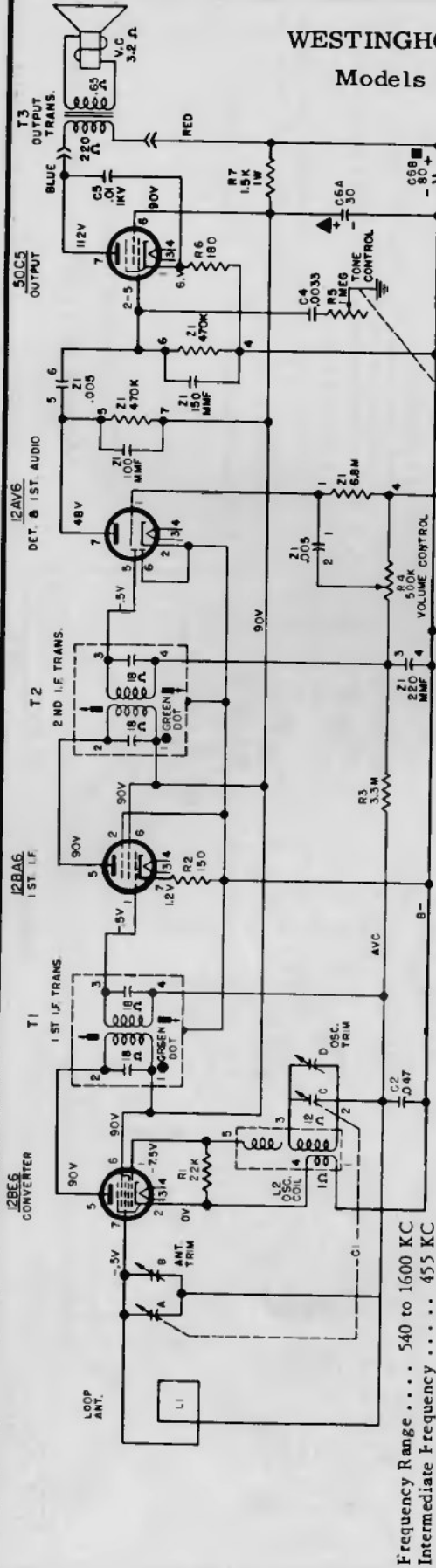

Frequency Range . . . 540 to 1600 KC
Intermediate Frequency . . . 455 KC

NOTES:
1. ALL VOLTAGES MEASURED FROM COMMON NEGATIVE USING A V.T.V.M., VOLUME CONTROL AT MINIMUM, TUNING CAPACITOR AT MAXIMUM LINE VOLTAGE SET AT 117V. A.C. READINGS SHOULD BE AS SHOWN ±20%.
2. ALL CAPACITANCE VALUES IN MFD. AND ALL RESISTANCE VALUES IN OHMS UNLESS OTHERWISE SPECIFIED.

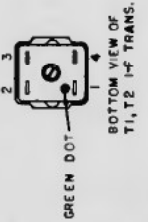
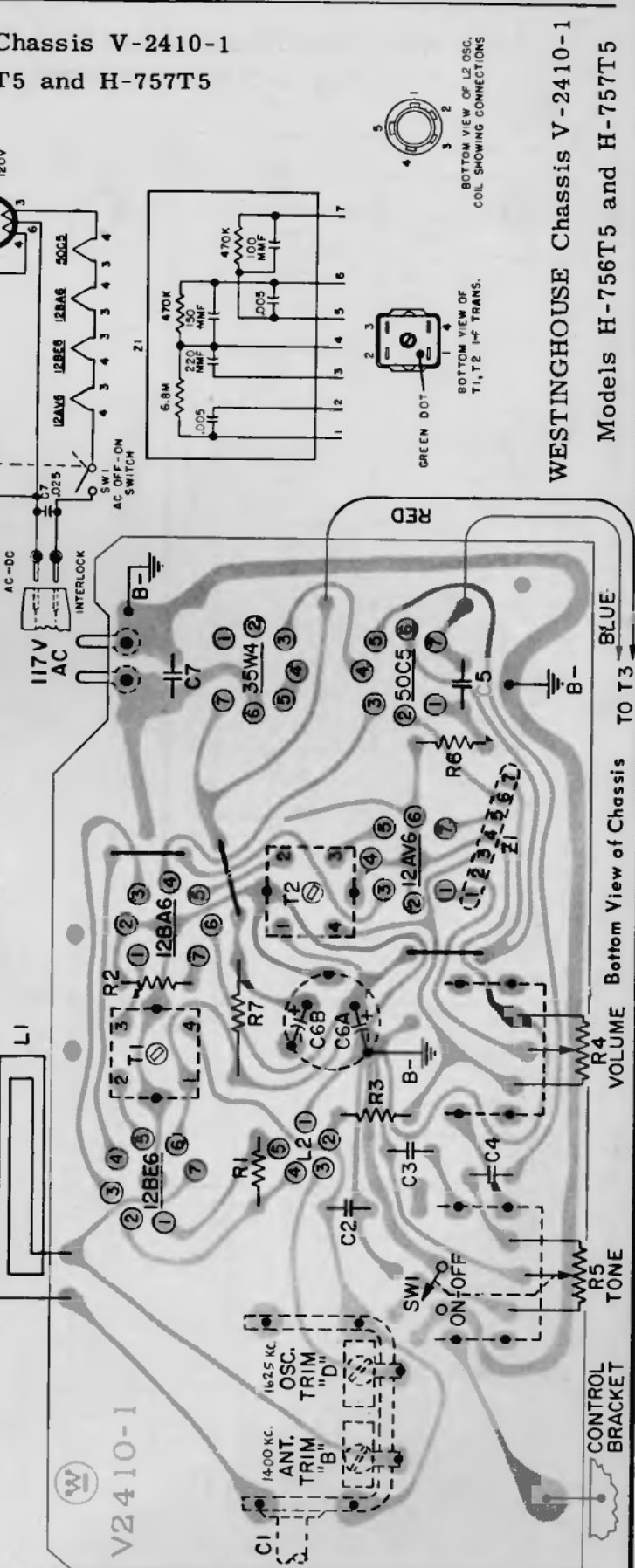

WESTINGHOUSE Chassis V-2410-2
Models H-759T6 and H-760T6

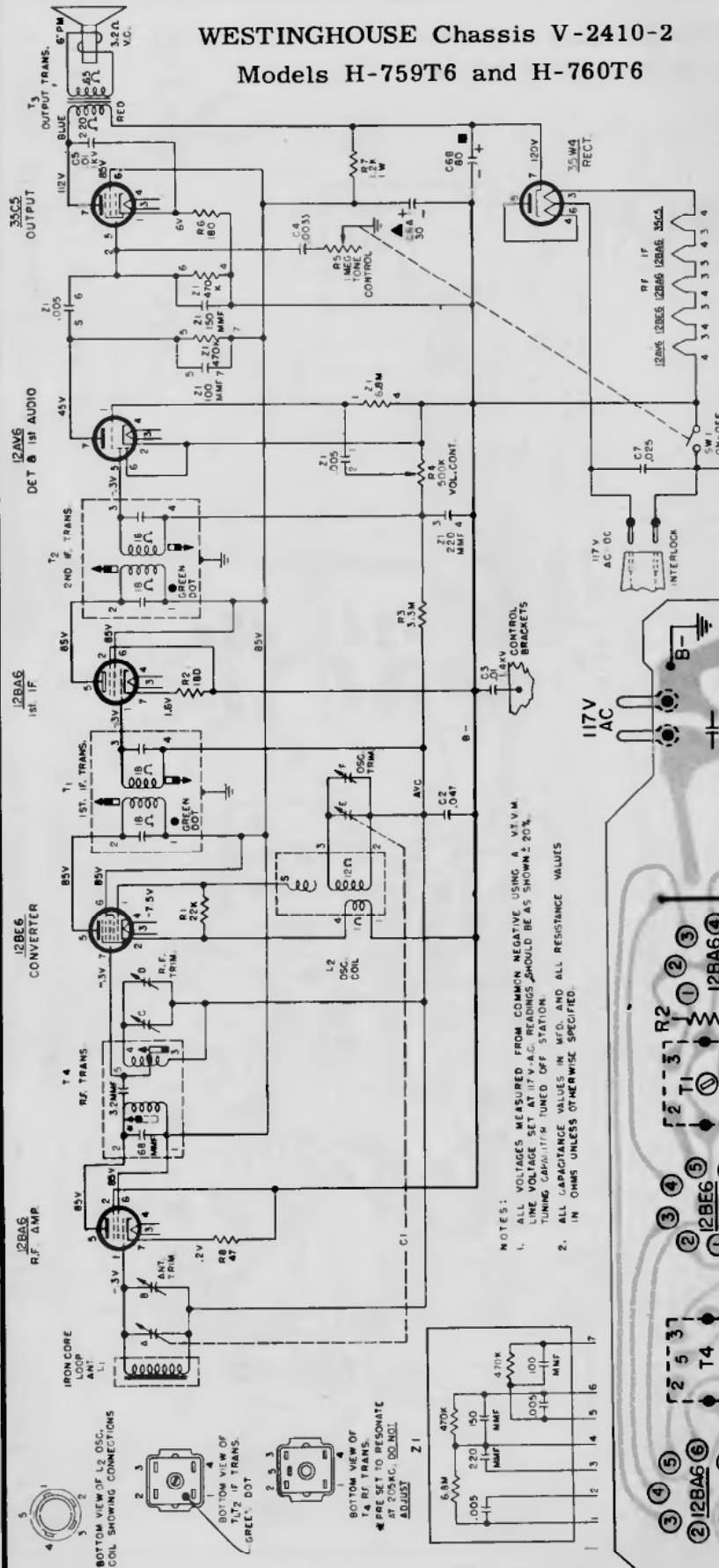

CHASSIS REMOVAL

1. Remove four screws, two from top corners on cabinet back and two from cabinet bottom.
2. Slide cabinet-front and attached chassis out from cabinet.

CHASSIS REPLACEMENT

1. Slide chassis and attached cabinet-front into cabinet, making sure that etched circuit board enters the groove provided in the cabinet.
2. Replace screws removed in "Chassis Removal".

WESTINGHOUSE Chassis V-2410-2
Models H-759T6 and H-760T6

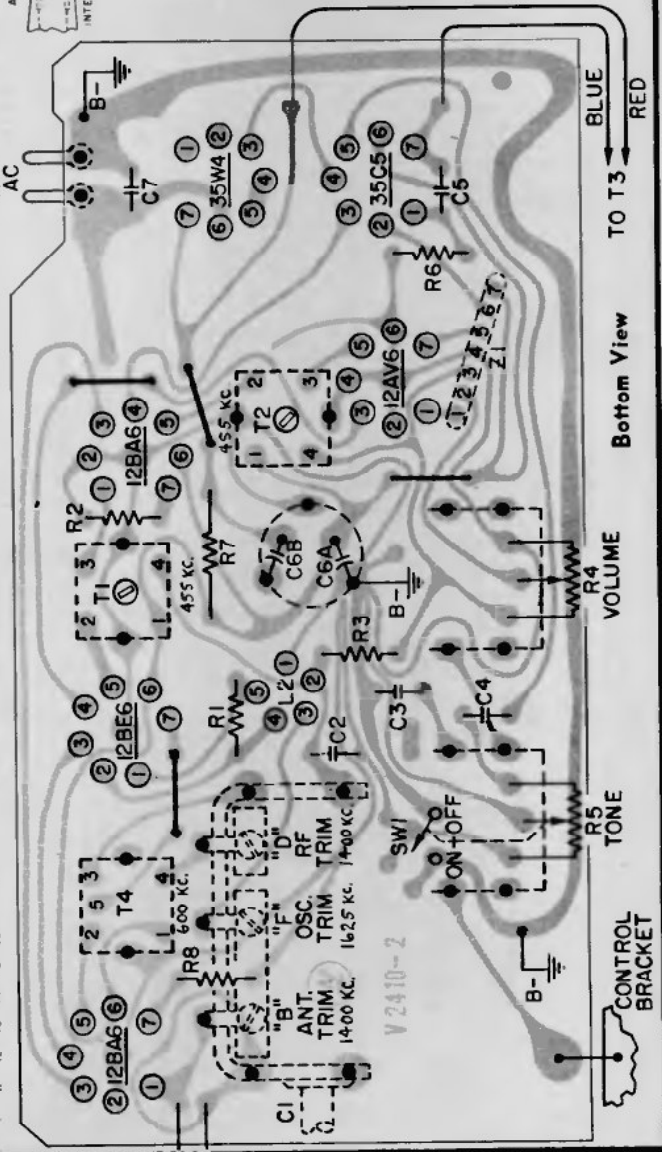

NOTES:
 1. ALL VOLTAGES MEASURED FROM COMMON NEGATIVE USING A VTVM. LINE VOLTAGE SET AT 117 V. A.C. READINGS SHOULD BE AS SHOWN ± 20%. TUNING CAPACITORS TUNED OFF STATION.
 2. ALL CAPACITANCE VALUES IN MFD. AND ALL RESISTANCE VALUES IN OHMS UNLESS OTHERWISE SPECIFIED.

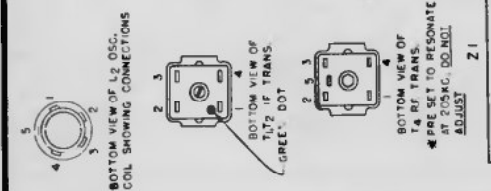

VOLUME R-21, MOST-OFTEN-NEEDED 1961 RADIO SERVICING INFORMATION

WESTINGHOUSE Chassis V-2512-3, used in Models H-F1010A, H-F1011A, H-F1012A, H-F1013A, H-F1050B, H-F1051B, H-F1052B, H-F1053B

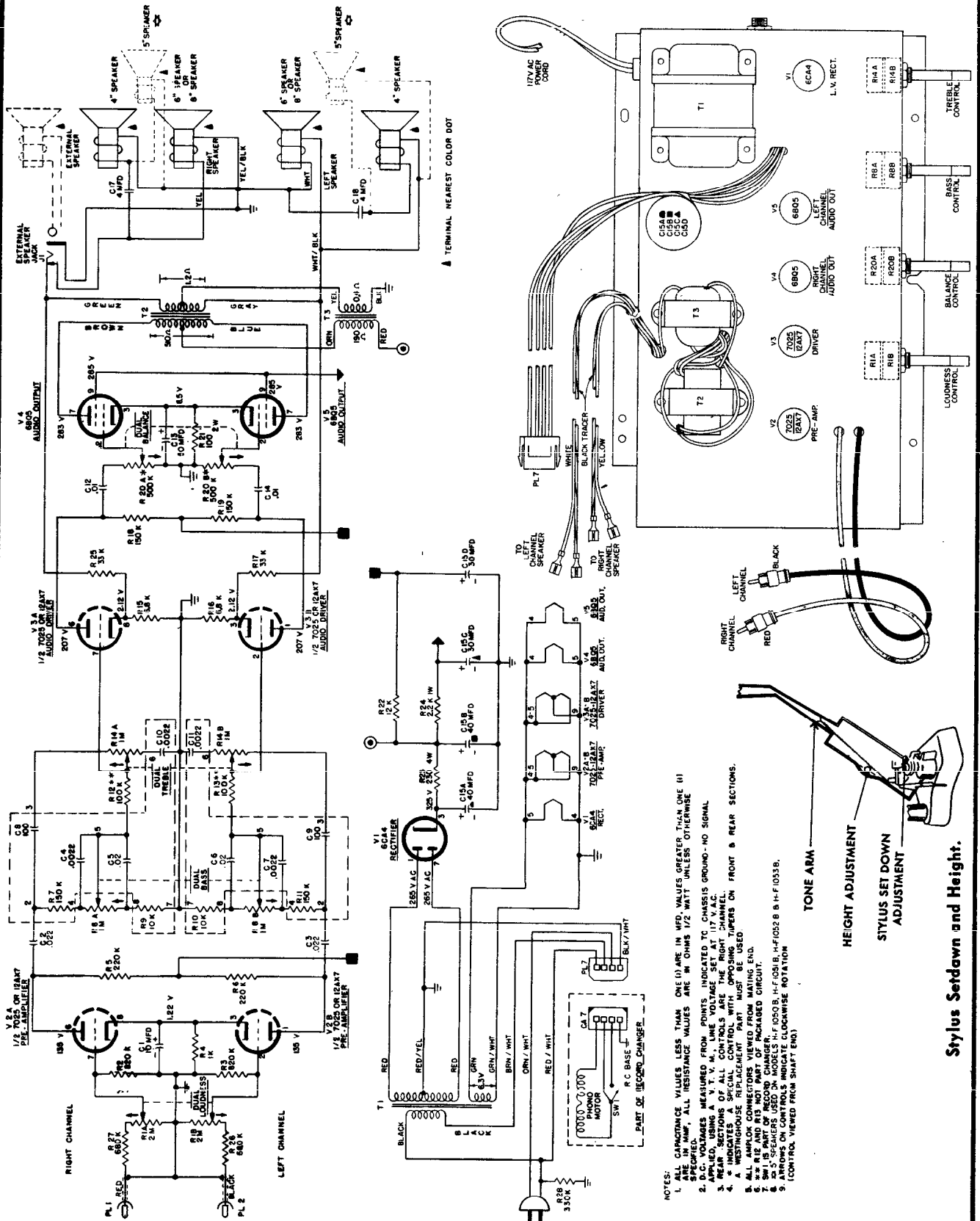

VOLUME R-21, MOST-OFTEN-NEEDED 1961 RADIO SERVICING INFORMATION

WESTINGHOUSE Chassis V-2508-7, Models H-61MP2, H-61MP3

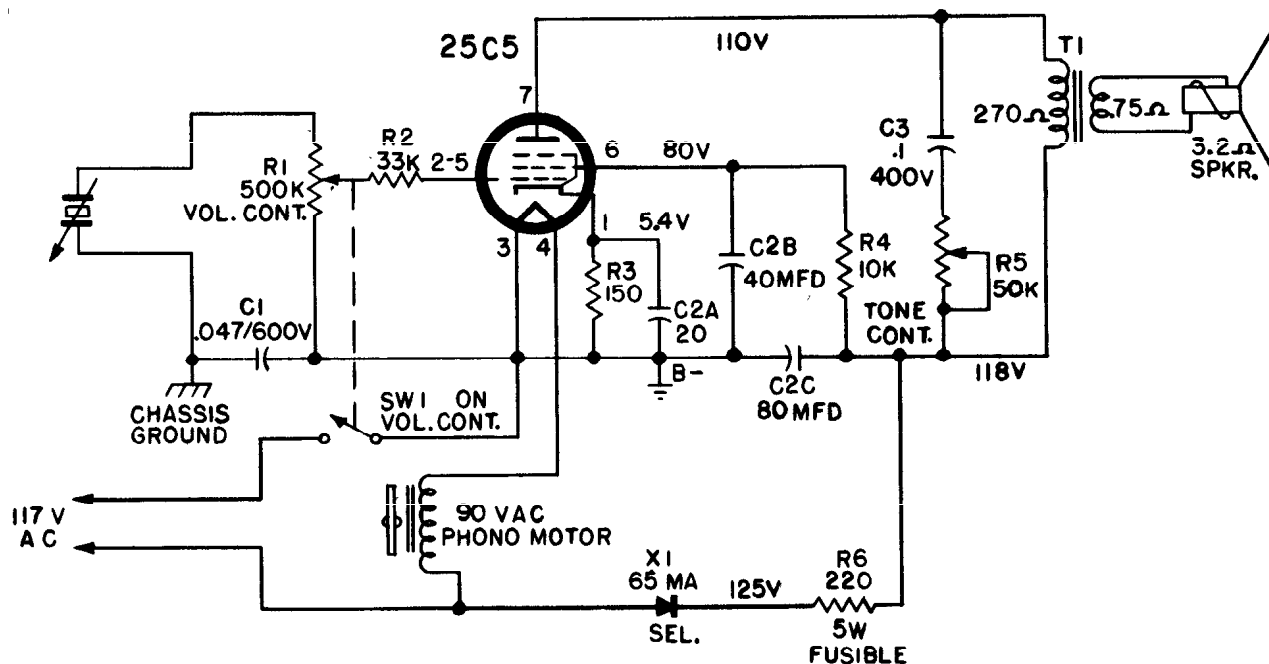

WESTINGHOUSE Chassis V-2508-3, V-2508-6, Models H-64ACS1, H-64ACS2

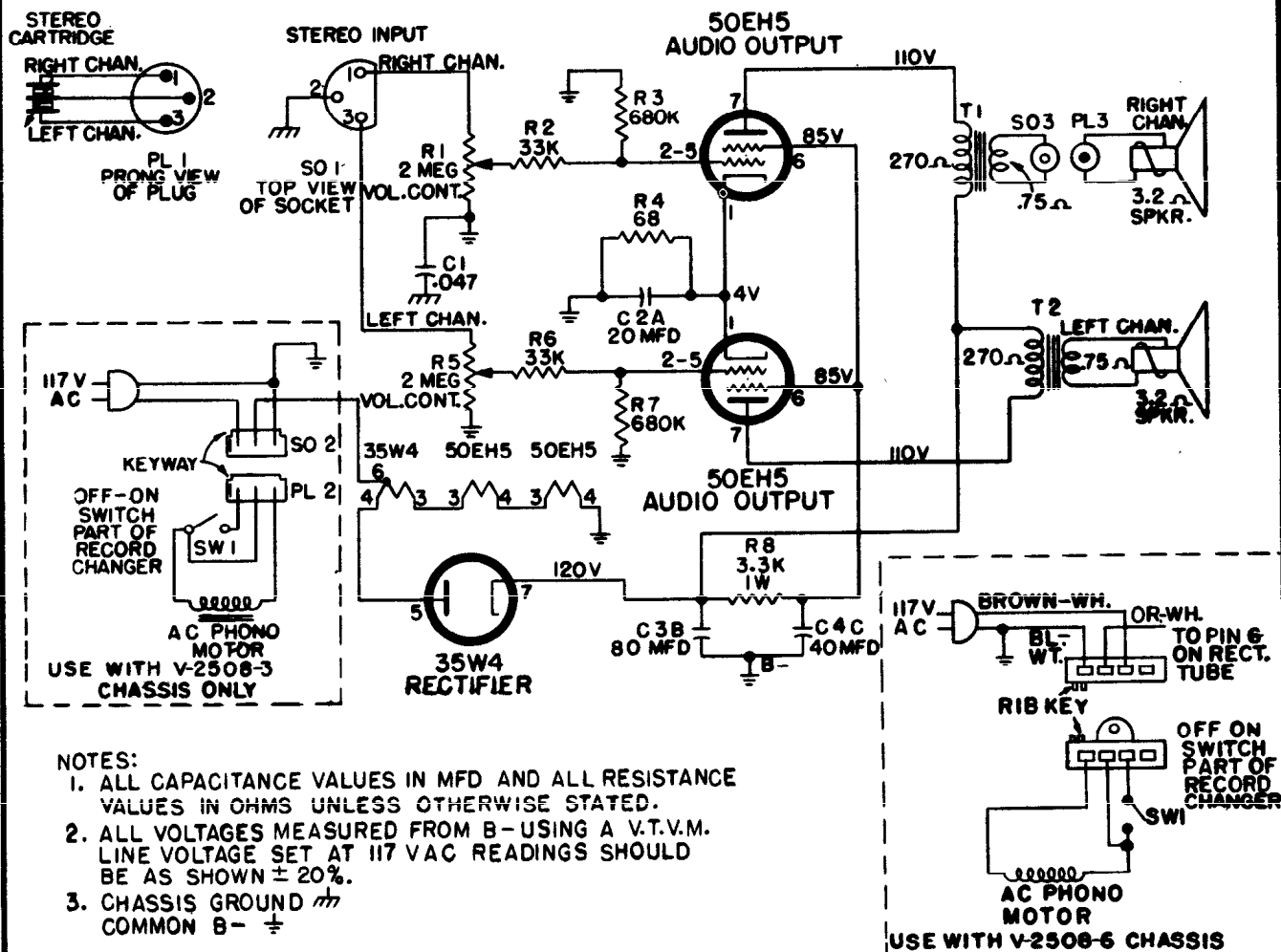

VOLUME R-21, MOST-OFTEN-NEEDED 1961 RADIO SERVICING INFORMATION

WESTINGHOUSE Chassis V-2507-8, Models H-70ACS1, H-70ACS3, H-70ACS4

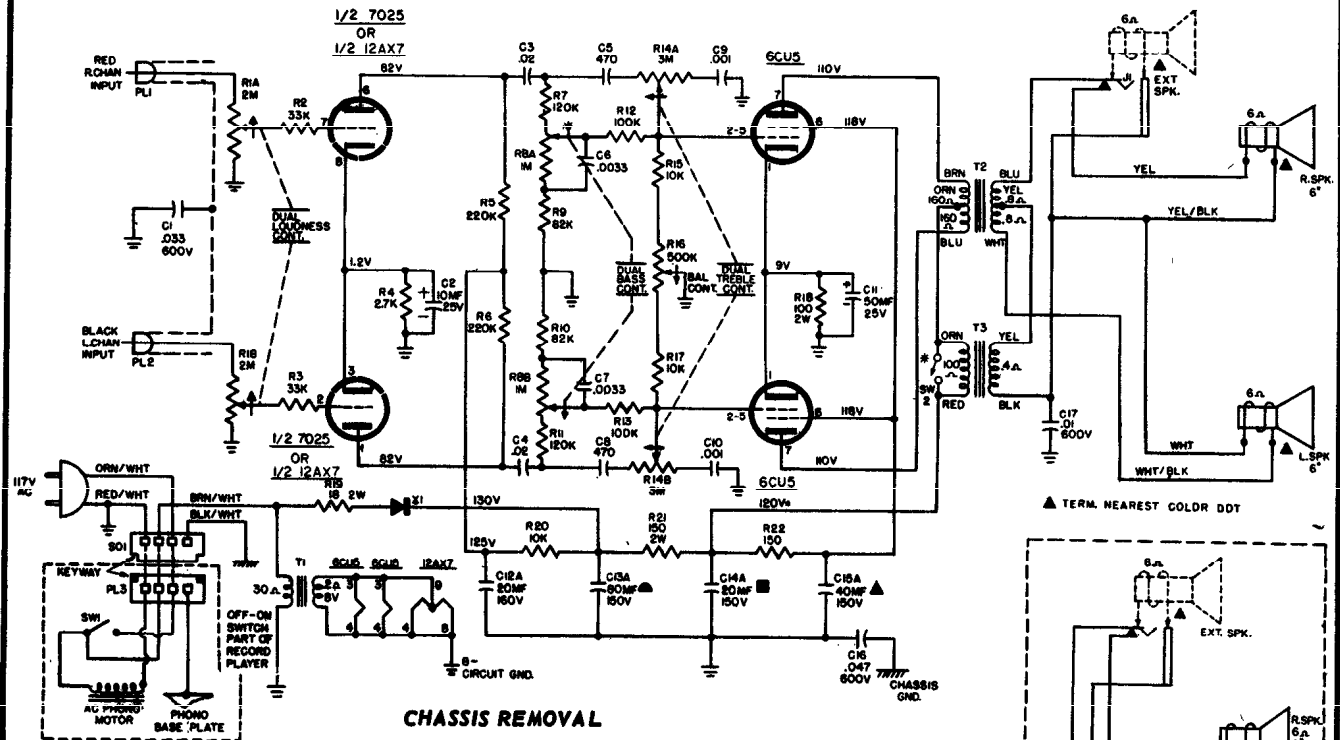

CHASSIS REMOVAL

1. Remove control knobs.
 2. Disconnect Amp-Lok type plug from record changer.
 3. Remove phono plugs from record changer noting color of cables and their respective jacks.
 4. Disconnect speaker leads noting connections with regard to lead color and speaker phasing dots.
 5. Remove two nuts securing left speaker baffle and remove baffle.
 6. Remove four nuts securing chassis and remove chassis.
- NOTE: Be sure during chassis installation that phono cables to changer and leads to speakers are properly phased (refer to schematic diagram for speaker lead color coding).

NOTES:
 1. ALL CAPACITANCE VALUES LESS THAN 1 ARE IN MFD, AND VALUES GREATER THAN 1 ARE IN MMFD, WHILE ALL RESISTANCE VALUES ARE IN OHMS 1/2 WATT, UNLESS OTHERWISE SPECIFIED.
 2. D.C. VOLTAGES MEASURED FROM B-USING VTVM, LINE VOLT SET AT 117 V.A.C. READINGS SHOULD BE WITHIN 10%.
 3. AMPLOK CONNECTORS VIEWED FROM CONTACT END.
 4. REAR SECTIONS OF ALL CONTROLS ARE RIGHT CHANNEL.
 5. ARROWS ON CONTROLS INDICATE CLOCKWISE ROTATION (CONTROL VIEWED FROM SHAFT END).
 * SW2 USED IN EARLY PRODUCTION ONLY, THIS SWITCH IS OPEN IN STEREO POSITION.

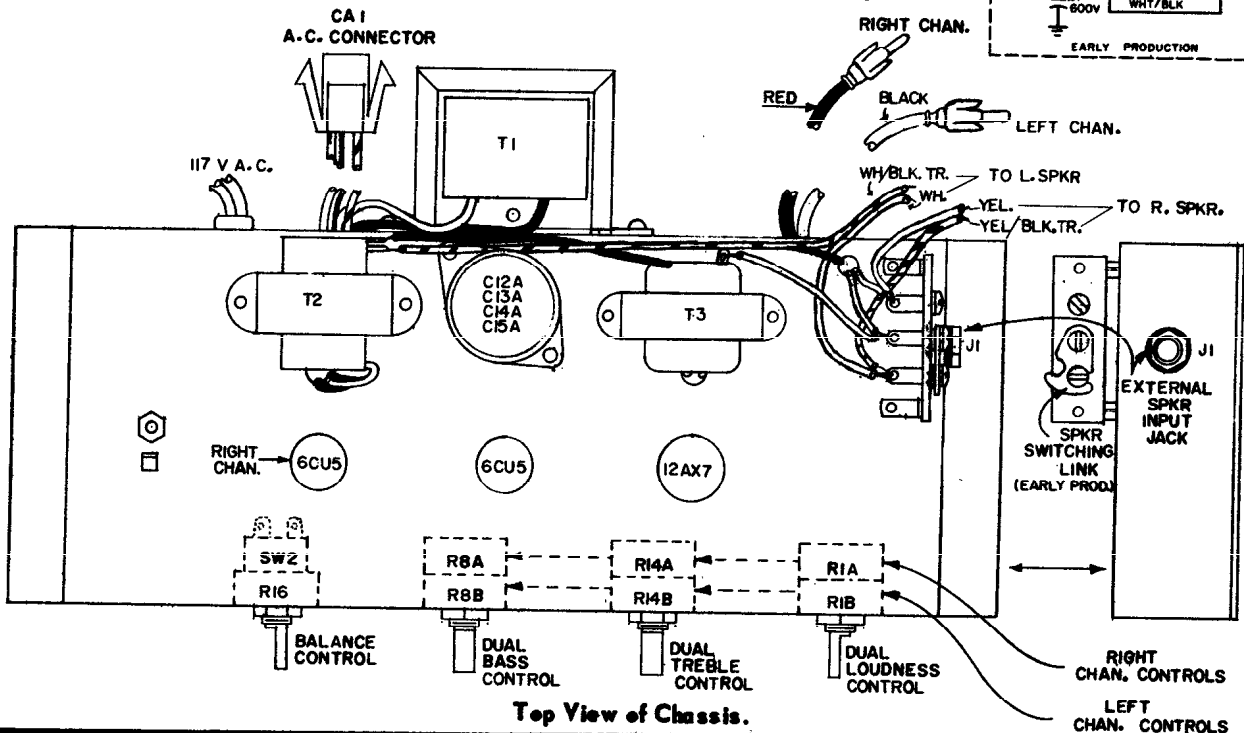
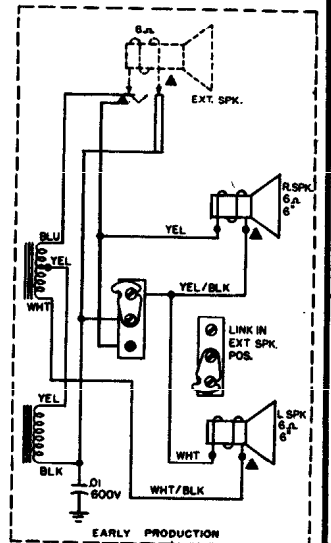

Top View of Chassis.

WESTINGHOUSE Chassis V-2507-6
Models H-68ACS1 and H-68ACS2

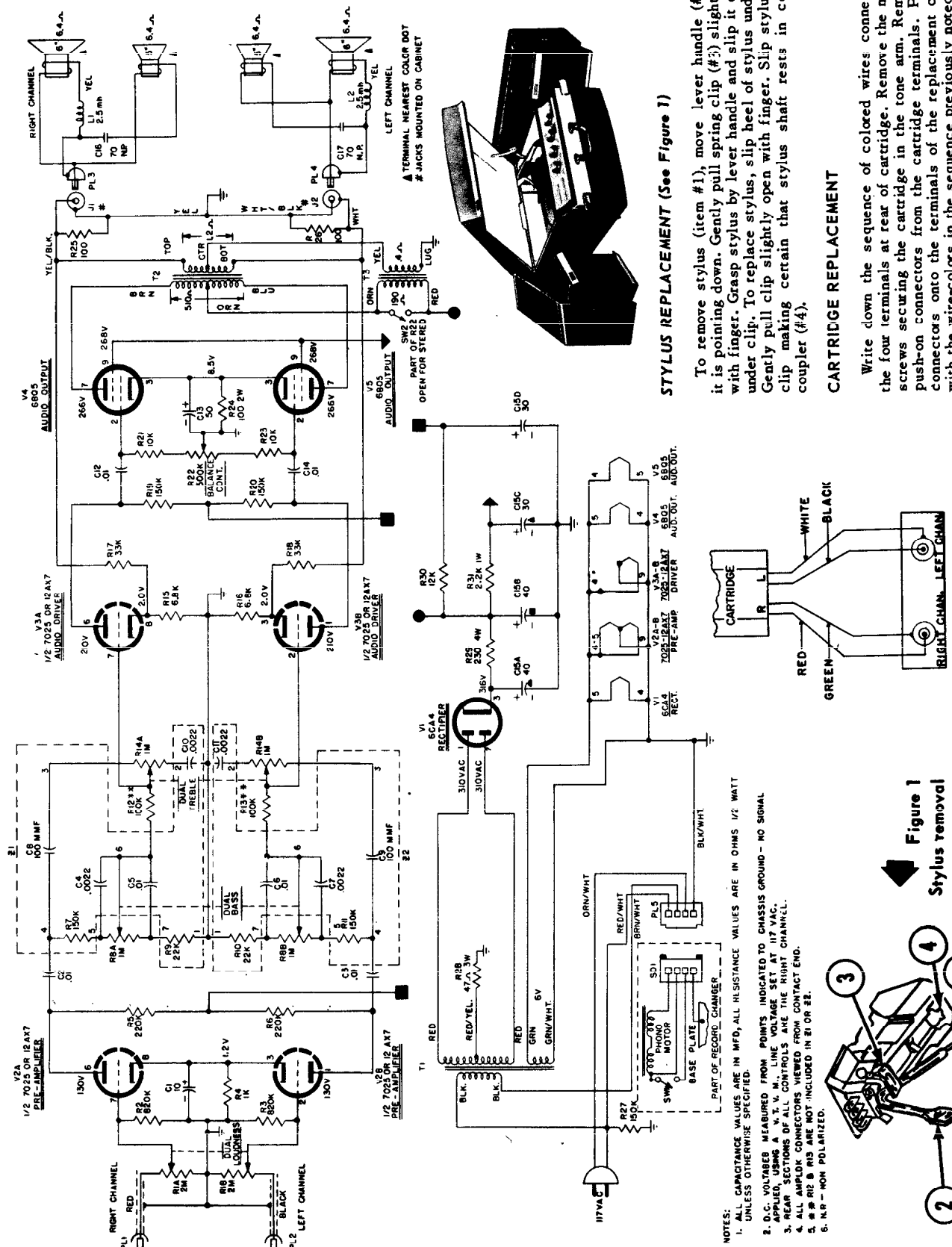

STYLUS REPLACEMENT (See Figure 1)

To remove stylus (item #1), move lever handle (#2) until it is pointing down. Gently pull spring clip (#3) slightly open with finger. Grasp stylus by lever handle and slip it out from under clip. To replace stylus, slip heel of stylus under clip. Gently pull clip slightly open with finger. Slip stylus under clip making certain that stylus shaft rests in center of coupler (#4).

CARTRIDGE REPLACEMENT

Write down the sequence of colored wires connecting to the four terminals at rear of cartridge. Remove the mounting screws securing the cartridge in the tone arm. Remove the push-on connectors from the cartridge terminals. Push the connectors onto the terminals of the replacement cartridge with the wire-colors in the sequence previously noted for the original cartridge.

Figure 2 - Cartridge terminal wiring.

Figure 1
Stylus removal and replacement.

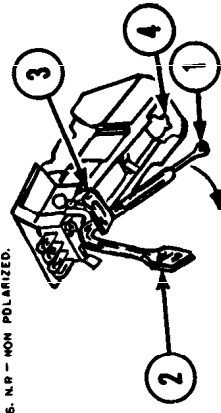

- NOTES:
1. ALL CAPACITANCE VALUES ARE IN MFD, ALL RESISTANCE VALUES ARE IN OHMS 1/2 WATT UNLESS OTHERWISE SPECIFIED.
 2. D.C. VOLTTAGES MEASURED FROM POINTS INDICATED BY CHASSIS GROUND - NO SIGNAL APPLIED, SECTION OF A.C. LINE VOLTAGE SET AT 117 VAC.
 3. REAR JACK CONNECTORS OF A.L. CONTROLS ARE THE RIGHT CHANNEL.
 4. ALL WIRE CONNECTORS VIEWED FROM CONTACT END.
 5. #1, #2 & #3 ARE NOT INCLUDED IN #1 OR #2.
 6. N.P. = NON POLARIZED.

VOLUME R-21, MOST-OFTEN-NEEDED 1961 RADIO SERVICING INFORMATION

WESTINGHOUSE Chassis V-2507-5
Models H-67ACS1, H-67ACS2

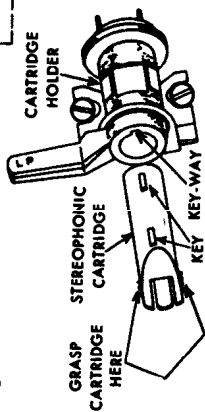
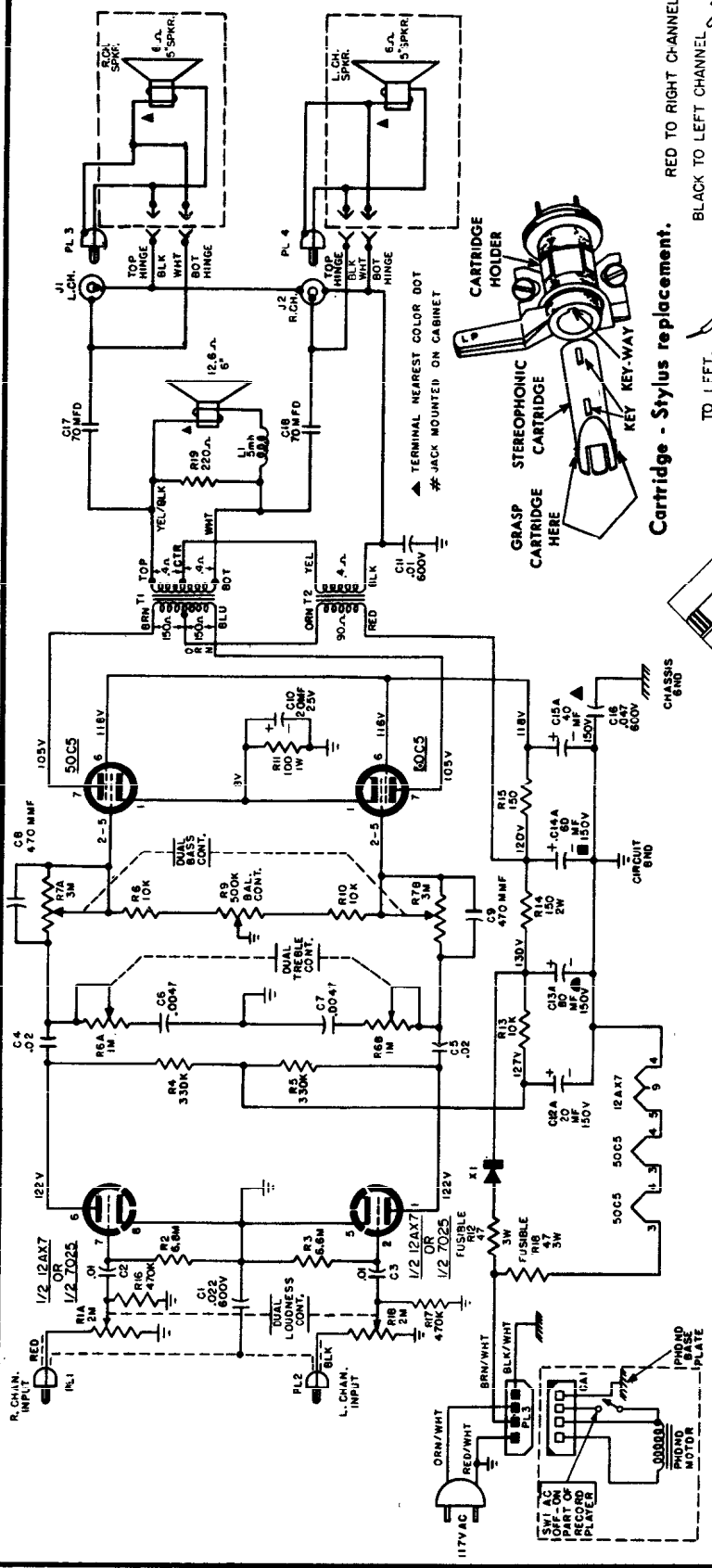

Cartridge - Stylus replacement.

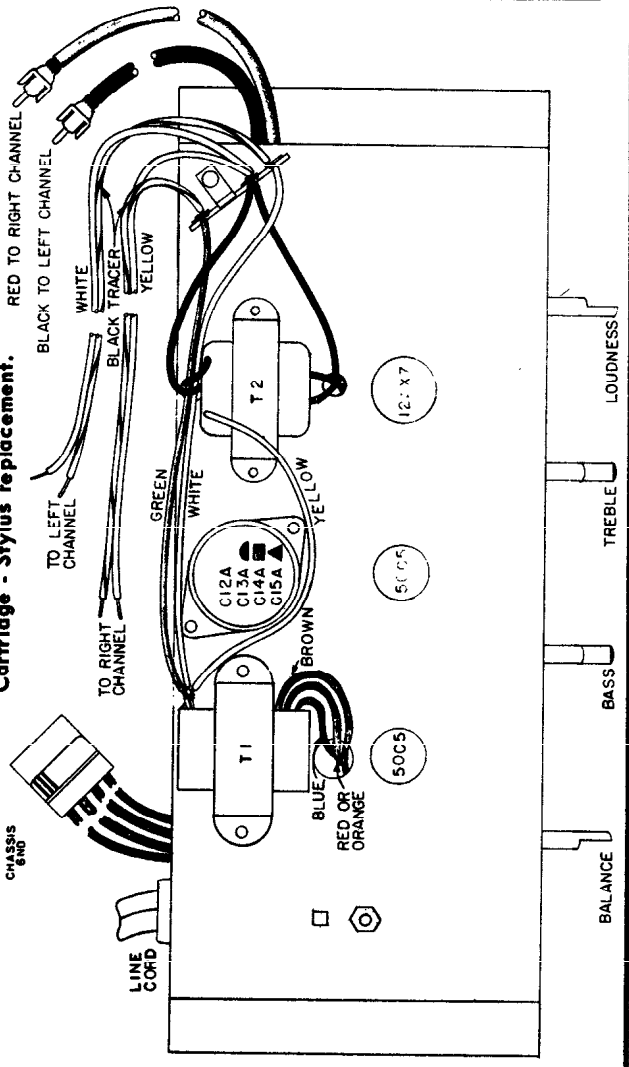

NOTES:
1. DC VOLTAGES MEASURED FROM CIRCUIT GROUND USING A VTVM. LOUDNESS CONTROL AT MINIMUM.
2. ALL CAPACITANCE VALUES ARE IN MFD, AND ALL RESISTANCE VALUES IN OHM, 1/2 WATT, UNLESS OTHERWISE SPECIFIED.

CHASSIS REMOVAL

1. Remove control knobs. Remove the escutcheon mounting board attached to the cabinet by 4 Phillips screws. Remove the perforated tube service cover which is attached to the cabinet by 3 Phillips screws.
2. Remove the 4 Phillips screws holding the motorboard. Lift the motorboard.
3. Note the color and location of the two coax cables connecting to the record changer. Disconnect the amp-lok plug and the two coax cable plugs from the record changer. Remove the record changer.
4. Remove the 2 nuts holding the speaker to the cabinet front and remove the speaker. Note the connections of the speaker leads to the terminal board and unsolder them from the terminals.
5. Remove the 4 nuts holding the chassis and remove the chassis.

VOLUME R-21, MOST-OFTEN-NEEDED 1961 RADIO SERVICING INFORMATION

WESTINGHOUSE Chassis V-2507-4
Models H-66ACS1, H-66ACS2

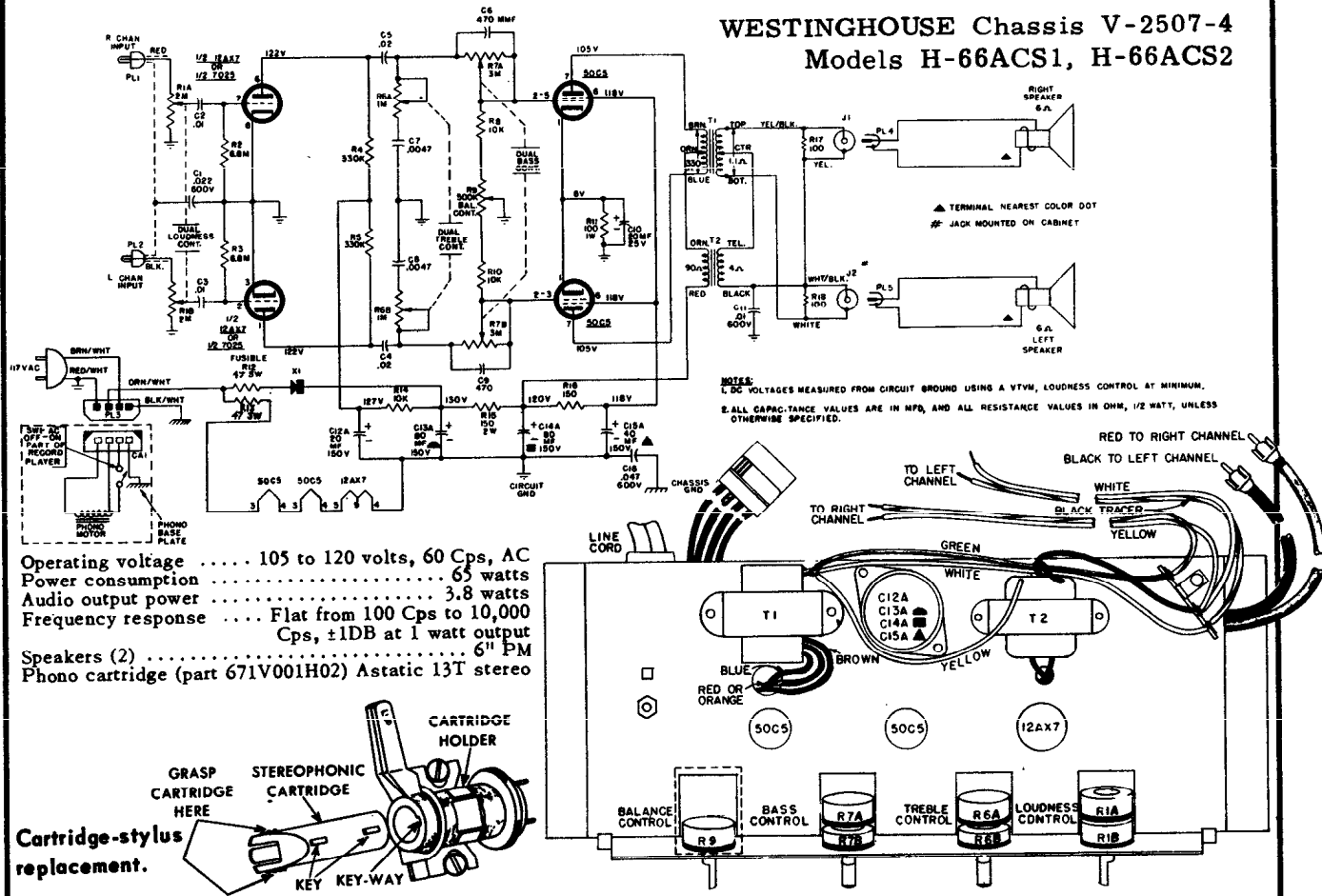

WESTINGHOUSE Chassis V-2508-5

Models H-63AC1, H-63AC2

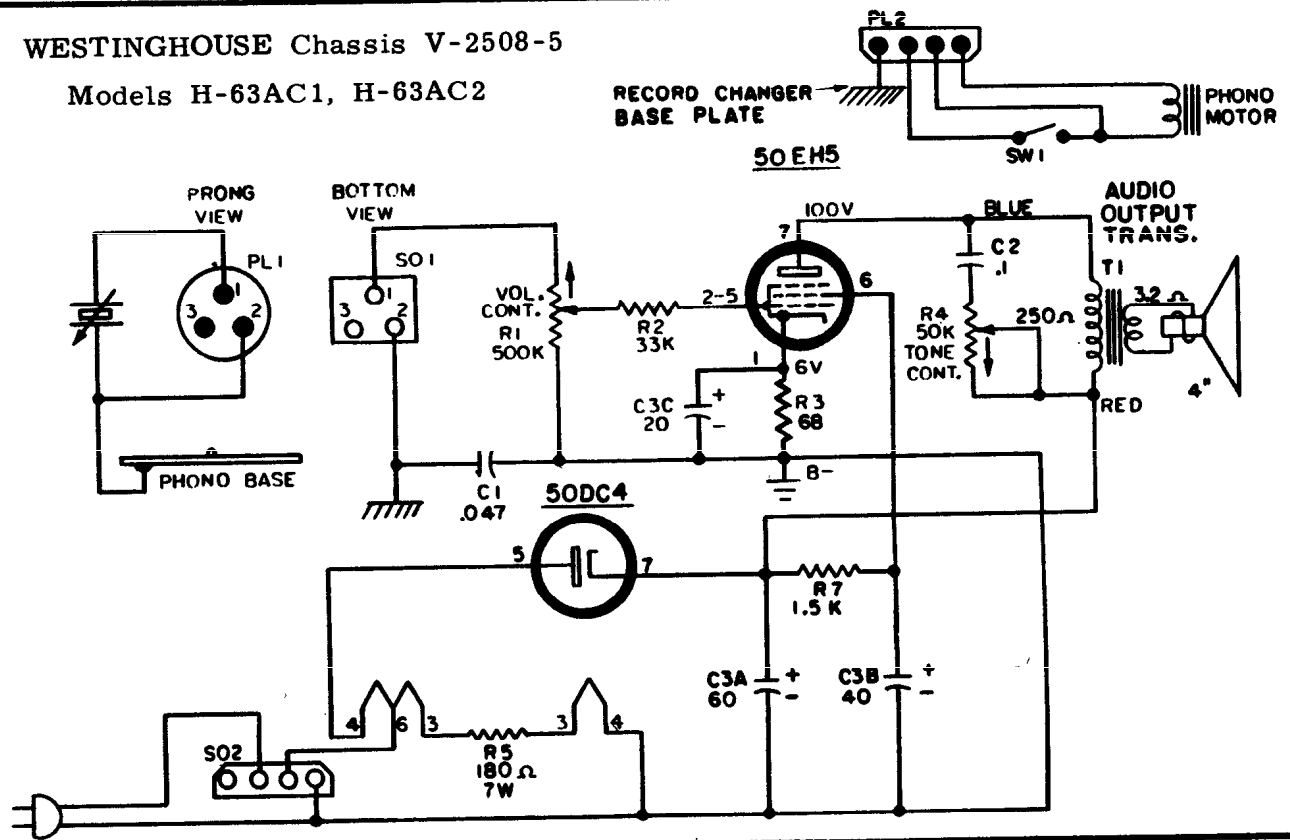

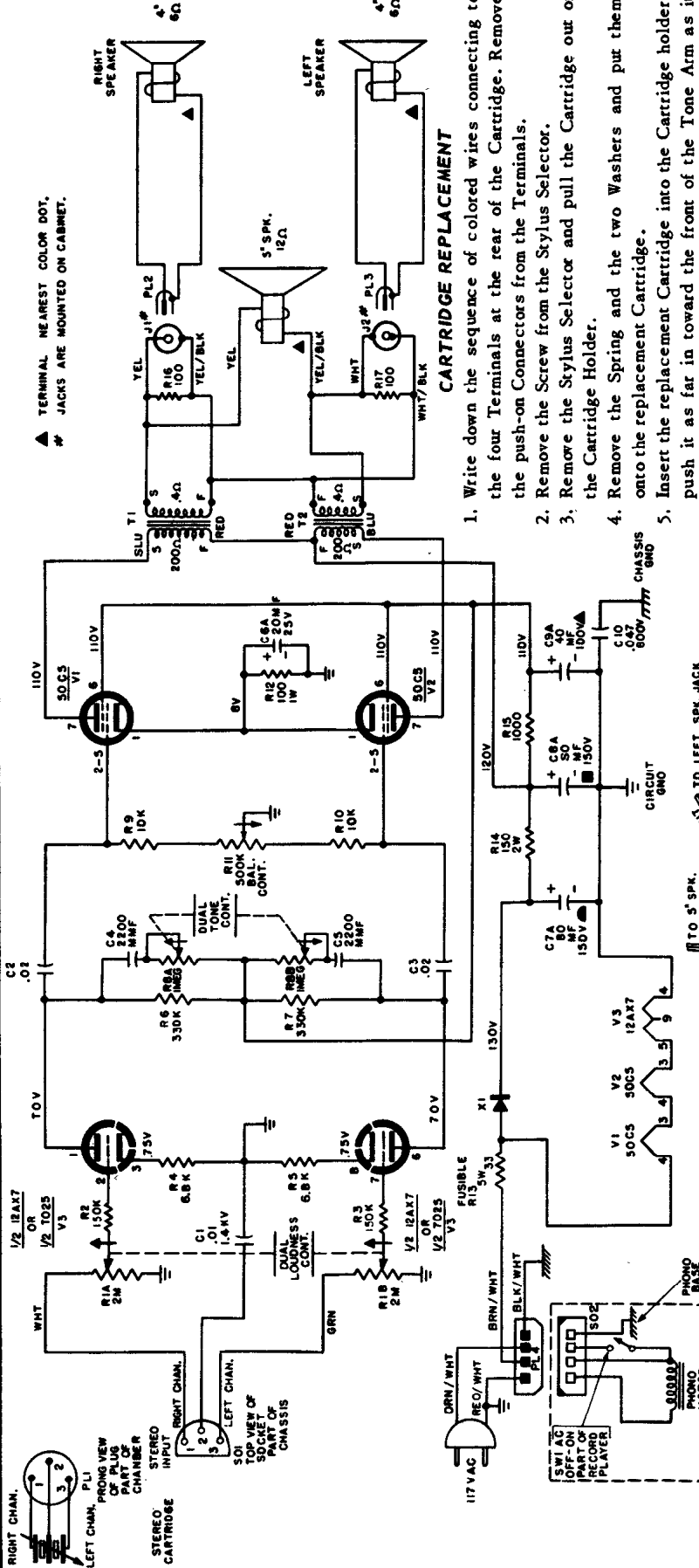

CARTRIDGE REPLACEMENT

1. Write down the sequence of colored wires connecting to the four Terminals at the rear of the Cartridge. Remove the push-on Connectors from the Terminals.
2. Remove the Screw from the Stylus Selector.
3. Remove the Stylus Selector and pull the Cartridge out of the Cartridge Holder.
4. Remove the Spring and the two Washers and put them onto the replacement Cartridge.
5. Insert the replacement Cartridge into the Cartridge holder; push it as far in toward the front of the Tone Arm as it will go and hold it there.
6. Put the Stylus Selector onto the Cartridge Shaft so that the Hole in the Stylus Selector lines up with the Hole in the Cartridge Shaft. Secure it in place with the Screw. Be sure that the "33-45" marking on the Stylus Selector faces upward and the Stylus marked SA-075 faces down.
7. Push the Connectors onto the Terminals with the wire colors in the sequence previously noted for the original cartridge.

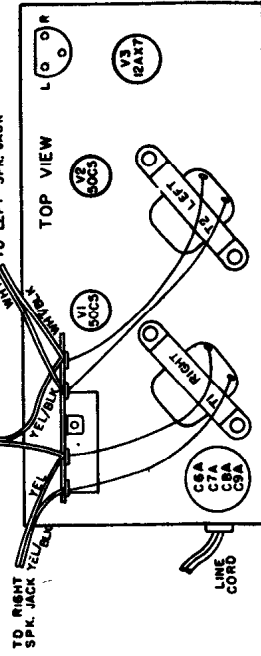
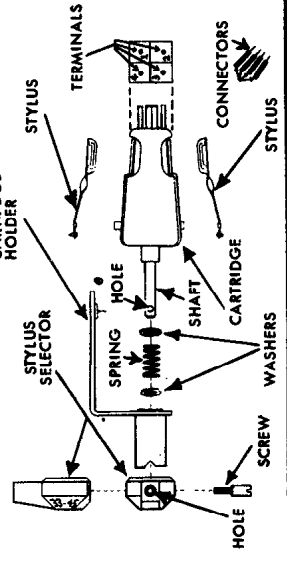

- NOTES:**
1. DC VOLTAGES MEASURED FROM CIRCUIT GROUND USING A VTVM. LOUDNESS CONTROL AT MINIMUM. LINE VOLTAGE SET AT 117 VAC. READINGS SHOULD BE AS SHOWN $\pm 20\%$.
 2. ALL CAPACITANCE VALUES LESS THAN ONE (1) ARE IN MFD. VALUES GREATER THAN ONE (1) ARE IN MMF.
 3. ALL RESISTANCE VALUES ARE IN OHMS 1/2 WATT UNLESS OTHERWISE SPECIFIED.
 4. DUAL CONTROLS ARE WIRED REAR SECTION RIGHT CHAN., - PANEL SECTION LEFT CHAN. - ARROWS ON CONTROLS INDICATE CLOCKWISE ROTATION (CONTROL VIEWED FROM SHAFT END.)

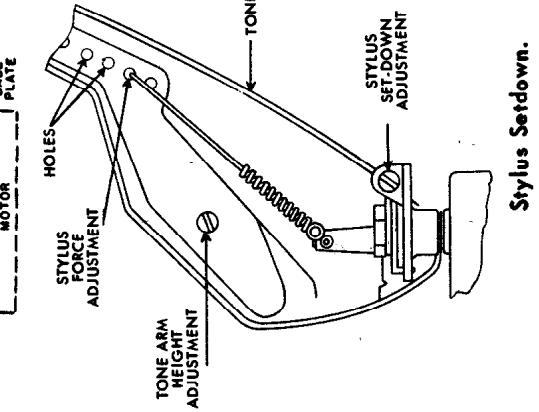

WESTINGHOUSE Chassis V-2506-5
Models H-65ACS1, H-65ACS2

Stylus Set-down.

ZENITH RADIO CORPORATION

MODEL SFD-660 PORTABLE

STEREOPHONIC PHONOGRAPH CHASSIS 5D20

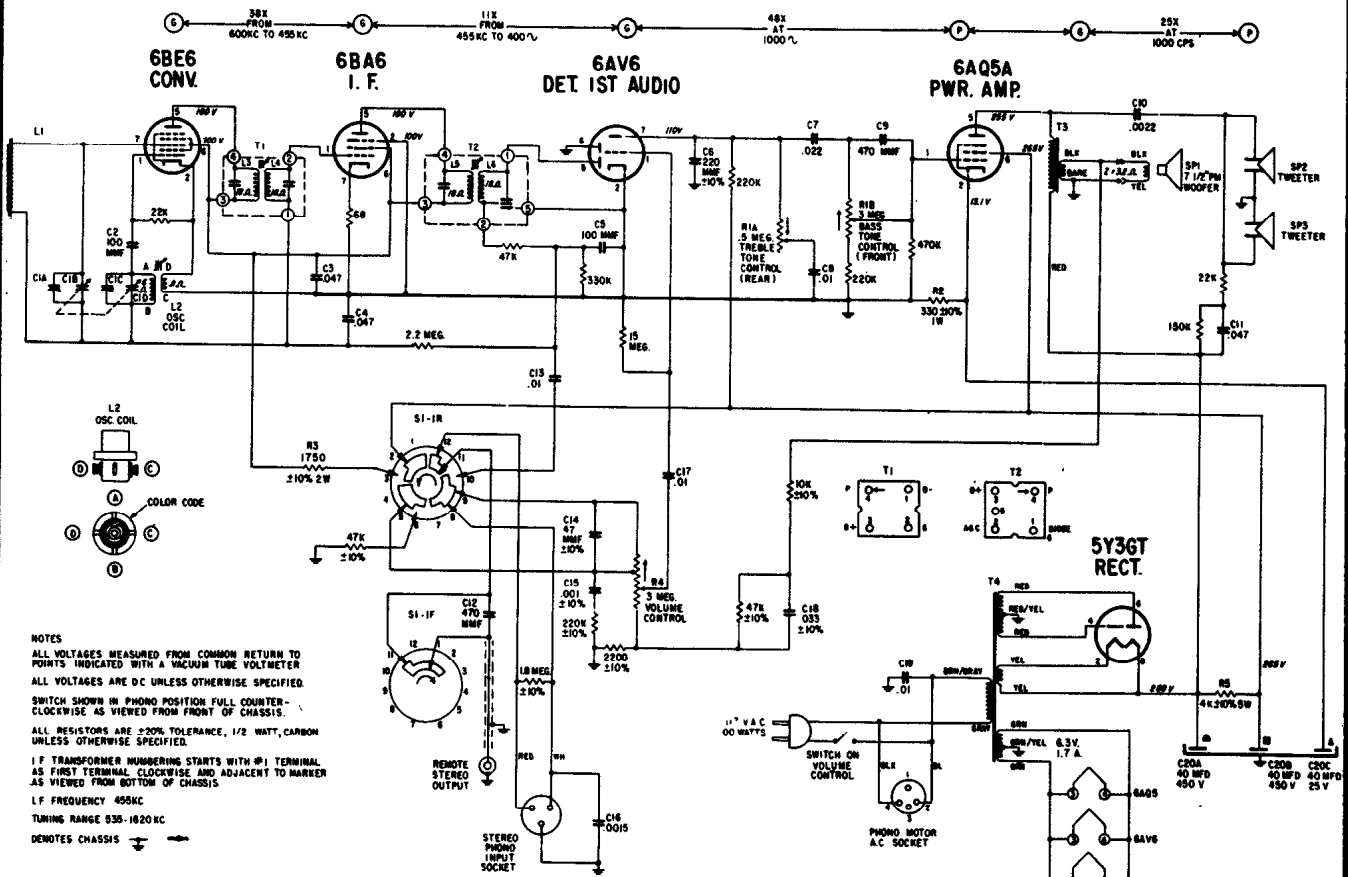

NOTES
 ALL VOLTAGES MEASURED FROM COMMON RETURN TO POINTS INDICATED WITH A VACUUM TUBE VOLTMETER
 ALL VOLTAGES ARE D.C. UNLESS OTHERWISE SPECIFIED.
 SWITCH SHOWN IN PHONO POSITION FULL COUNTER-CLOCKWISE AS VIEWED FROM FRONT OF CHASSIS.
 ALL RESISTORS ARE 5% TOLERANCE, 1/2 WATT, CARBON UNLESS OTHERWISE SPECIFIED.
 IF TRANSFORMER NUMBERING STARTS WITH #1 TERMINAL AS FIRST TERMINAL CLOCKWISE AND ADJACENT TO MARKER AS VIEWED FROM BOTTOM OF CHASSIS
 L.F. FREQUENCY 455 KC
 TUNING RANGE 930-1620 KC
 DENOTES CHASSIS

ANTENNA ASSEMBLY

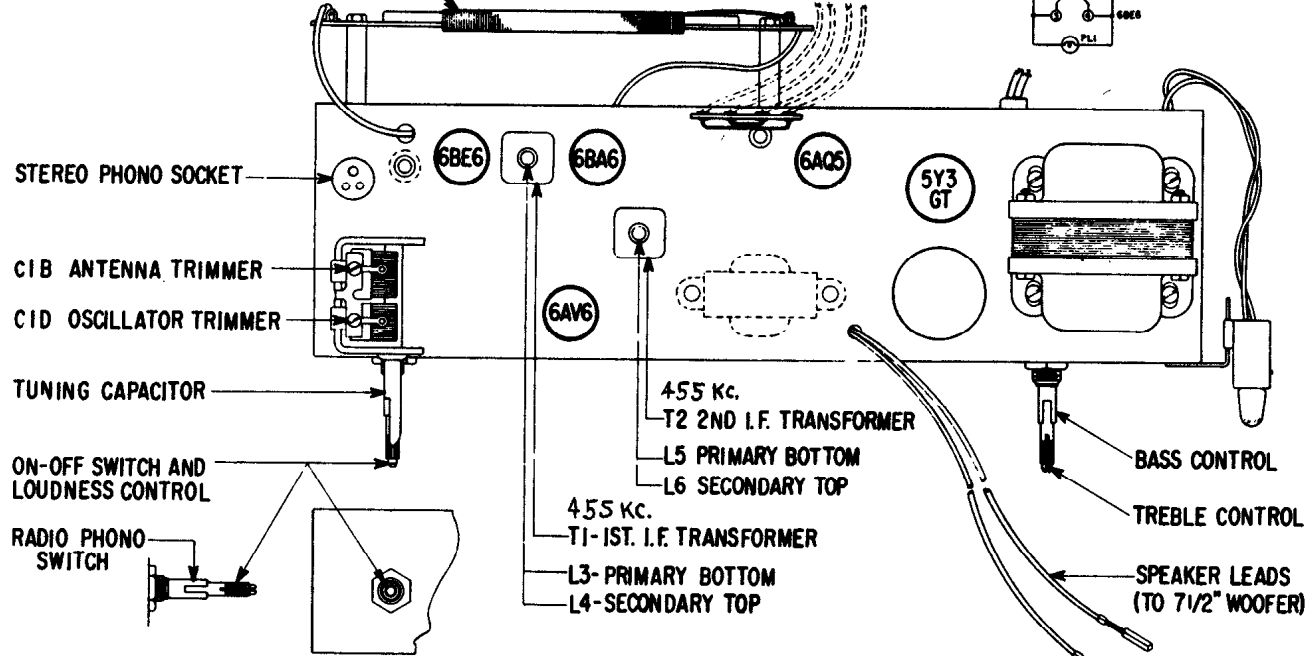

VOLUME R-21, MOST-OFTEN-NEEDED 1961 RADIO SERVICING INFORMATION

ZENITH RADIO

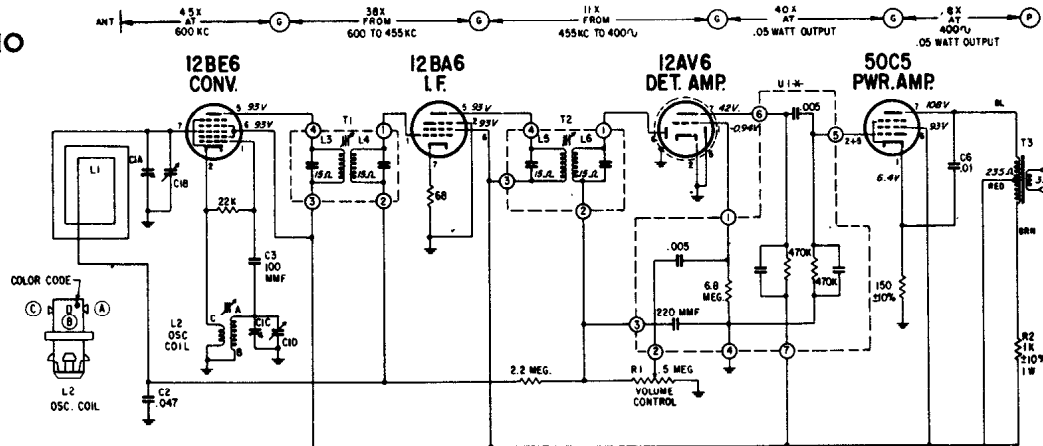

ZENITH RADIO

Chassis 5F03, used in Models XD60C, F, L, V.

Chassis 5E04 used in Models E514B, L, V, W, is the same electrically.

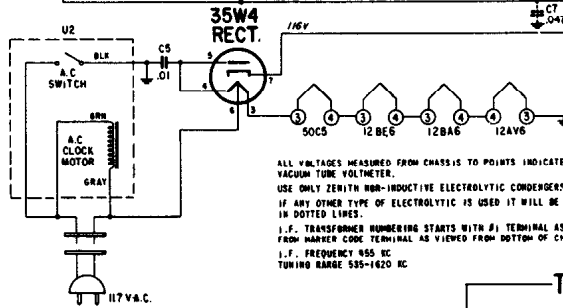

ALL VOLTAGES MEASURED FROM CHASSIS TO POINTS INDICATED WITH AN A.C., D.C. OR VACUUM TUBE VOLTMETER.
USE ONLY ZENITH NON-INDUCTIVE ELECTROLYTIC CONDENSERS FOR REPLACEMENT.
IF ANY OTHER TYPE OF ELECTROLYTIC IS USED IT WILL BE NECESSARY TO ADD CT SHOWN IN DOTTED LINES.
I.F. TRANSFORMER NUMBERING STARTS WITH J1 TERMINAL AS FIRST TERMINAL CLOCKWISE FROM MARKER CODE TERMINAL AS VIEWED FROM BOTTOM OF CHASSIS.
I.F. FREQUENCY 455 KC
TUNING RANGE 535-1620 KC

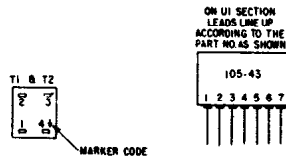

- T1 1ST I.F. TRANSFORMER
- L3 PRIMARY BOTTOM
- L4 SECONDARY TOP

- T2 2ND I.F. TRANSFORMER
- L5 PRIMARY BOTTOM
- L6 SECONDARY TOP

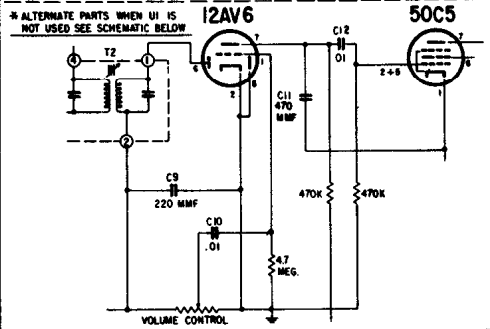

C1D OSCILLATOR TRIMMER

C1B ANTENNA TRIMMER

L2 OSCILLATOR COIL

SPEAKER LEADS

VOLUME CONTROL

ALIGNMENT PROCEDURE

Operation	Connect Oscillator To	Dummy Antenna	Input Sig. Frequency	Set Dial At	Trimmers	Purpose
1	Converter Grid	.5 Mfd	455 Kc.	600 Kc.	L3, L4, L5, L6	For I.F. Alignment.
2	One Turn Loop Coupled Loosely to Wave Magnet	—	1600 Kc.	1600 Kc.	C1D	Set Oscillator to Dial Scale
3		—	1400 Kc.	1400 Kc.	C1B	Align Antenna Stage

ZENITH RADIO MODELS F512F, C, W, L, CHASSIS 5F13

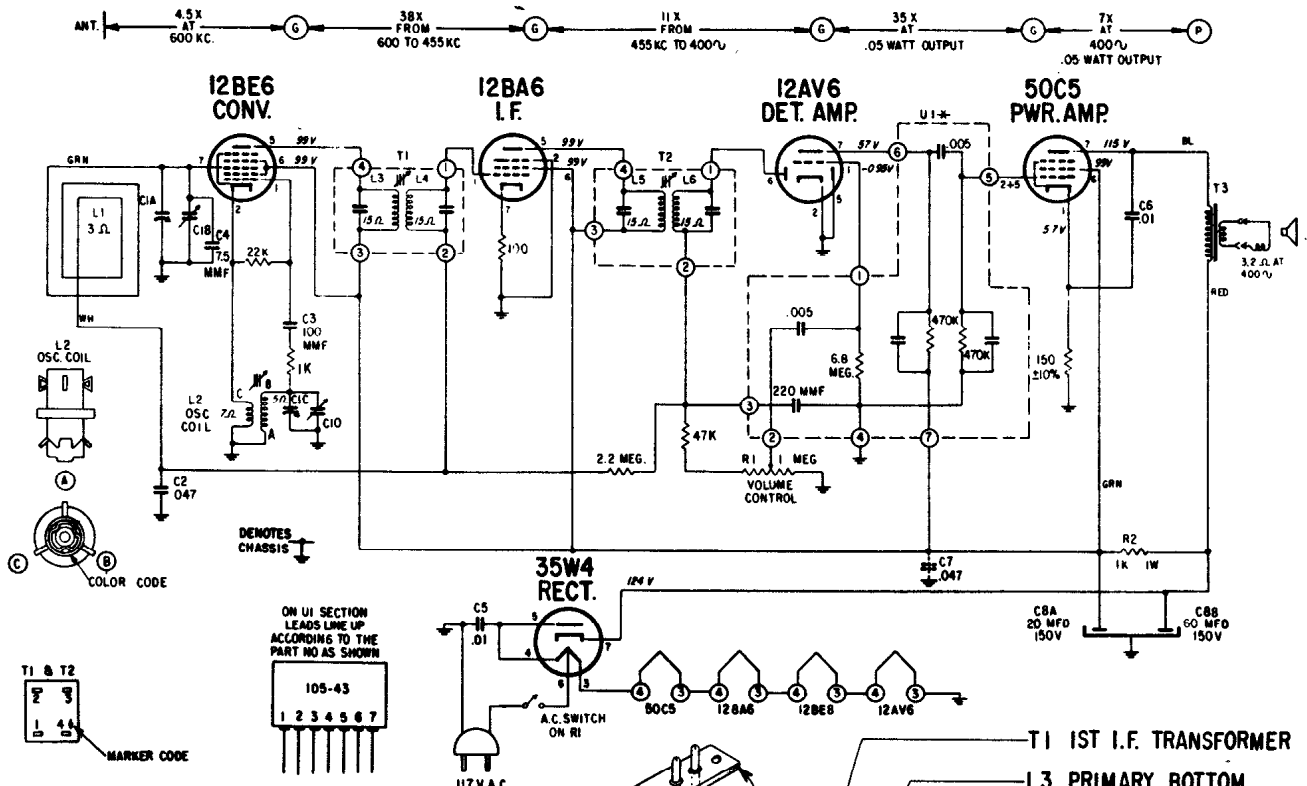

NOTES:
 ALL VOLTAGES MEASURED FROM CHASSIS TO POINTS INDICATED WITH AN A.C., D.C. OR VACUUM TUBE VOLTMETER.
 USE ONLY ZENITH NON-INDUCTIVE ELECTROLYTIC CONDENSERS FOR REPLACEMENT.
 IF ANY OTHER TYPE OF ELECTROLYTIC IS USED IT WILL BE NECESSARY TO ADD C7 SHOWN IN DOTTED LINES.
 I.F. TRANSFORMER NUMBERING STARTS WITH #1 TERMINAL AS FIRST TERMINAL CLOCKWISE FROM MARKER CODE TERMINAL AS VIEWED FROM BOTTOM OF CHASSIS.
 I.F. FREQUENCY 455 KC
 TUNING RANGE 535-1620 KC
 ALL RESISTORS ±20% TOLERANCE, 1/2 WATT, CARBON UNLESS OTHERWISE SPECIFIED.

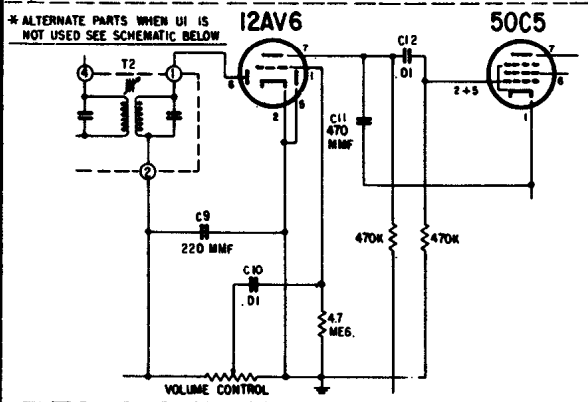
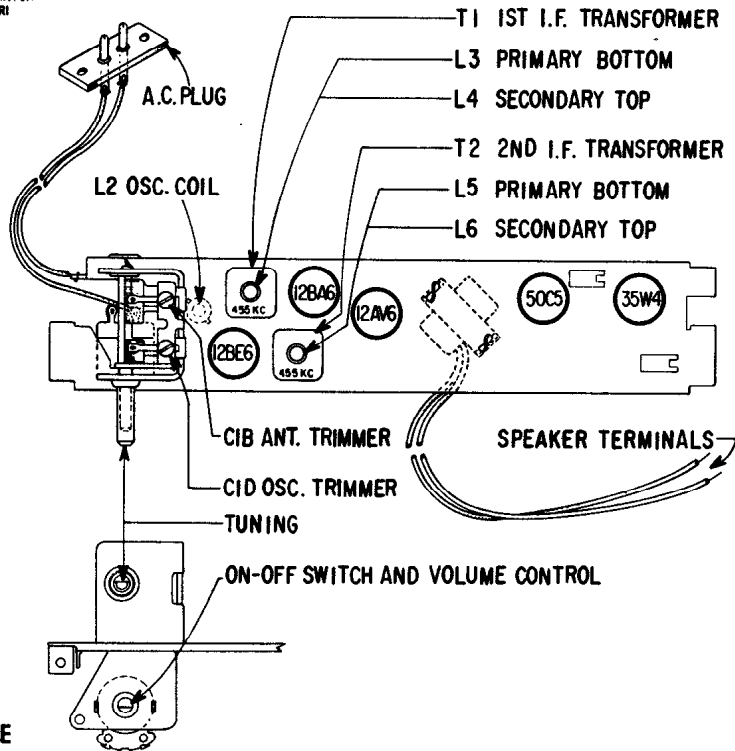

ALIGNMENT PROCEDURE

OPERATION	CONNECT OSCILLATOR TO	DUMMY ANTENNA	INPUT SIG. FREQUENCY	SET DIAL AT	TRIMMERS	PURPOSE
1	Converter Grid	.5 Mfd.	455 Kc.	600 Kc.	L3,4,5,6	For I.F. Alignment.
2	One Turn Loop Coupled Loosely to Wave Magnet	—	1600 Kc.	1600 Kc.	CID	Set Oscillator to Dial Scale
3		—	1400 Kc.	1400 Kc.	CIB	Align Antenna Stage

VOLUME R-21, MOST-OFTEN-NEEDED 1961 RADIO SERVICING INFORMATION

ZENITH RADIO CORPORATION MODELS XD50C, G, R, W, CHASSIS 5D12

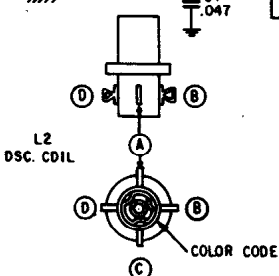
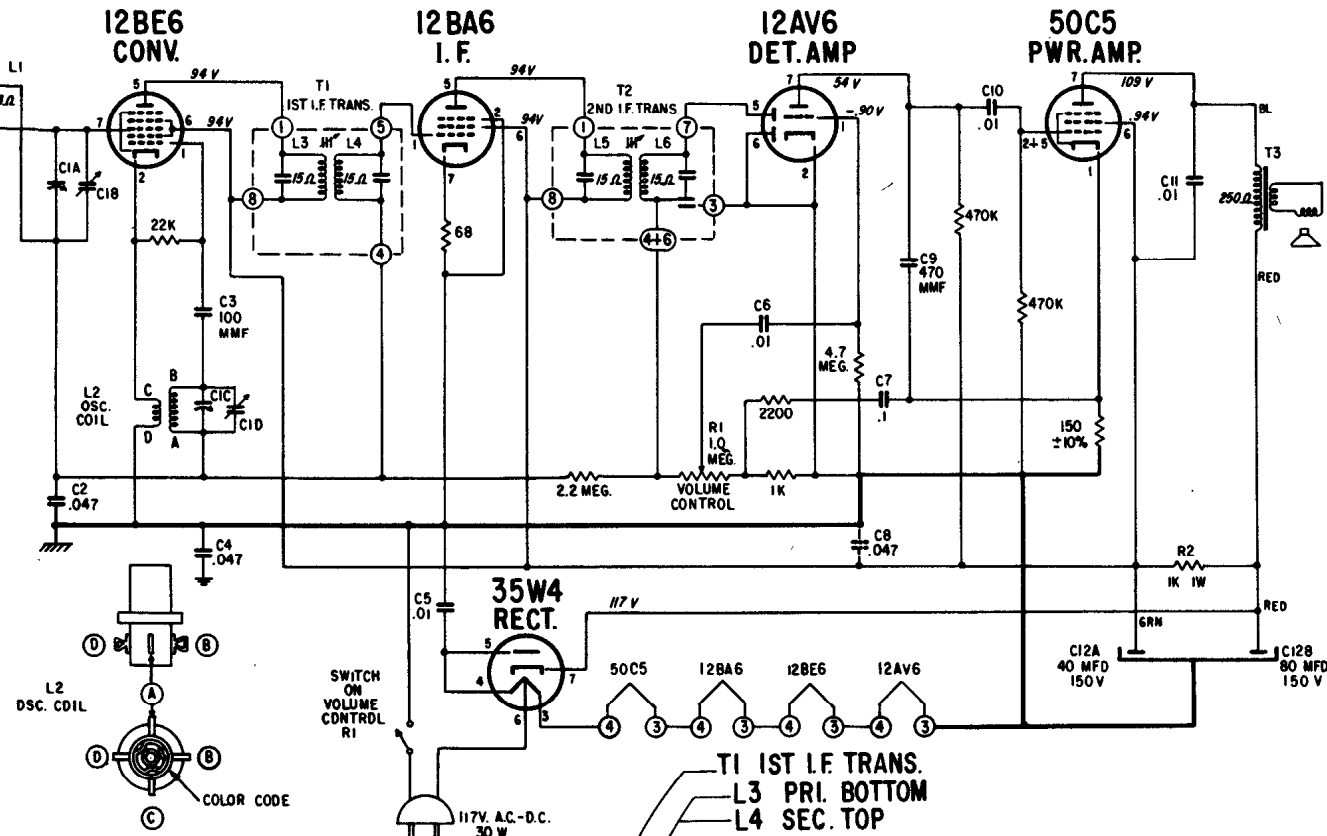
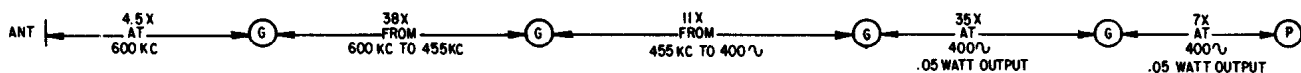

NOTES:
 ALL VOLTAGES MEASURED FROM COMMON RETURN TO POINTS INDICATED WITH AN A.C., D.C. OR VACUUM TUBE VOLTMETER
 ALL VOLTAGES ARE D.C. UNLESS OTHERWISE SPECIFIED.
 USE ONLY ZENITH NON-INDUCTIVE ELECTROLYTIC CONDENSERS FOR REPLACEMENT. IF ANY OTHER TYPE OF ELECTROLYTIC IS USED IT WILL BE NECESSARY TO ADD C8 SHOWN IN DOTTED LINES.
 I.F. TRANSFORMER NUMBERING STARTS WITH #1 TERMINAL, AS 1ST TERMINAL CLOCKWISE AND ADJACENT TO MARKER AS VIEWED FROM BOTTOM OF CHASSIS.
 ALL RESISTORS ±20% TOLERANCE, 1/2 WATT, CARBON UNLESS OTHERWISE SPECIFIED.
 I.F. FREQUENCY 455 KC.
 TUNING RANGE 535-1620 KC
 ⚡ DENOTES CHASSIS ⚡ DENOTES COMMON RETURN B-

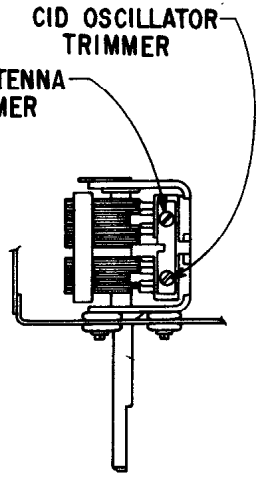
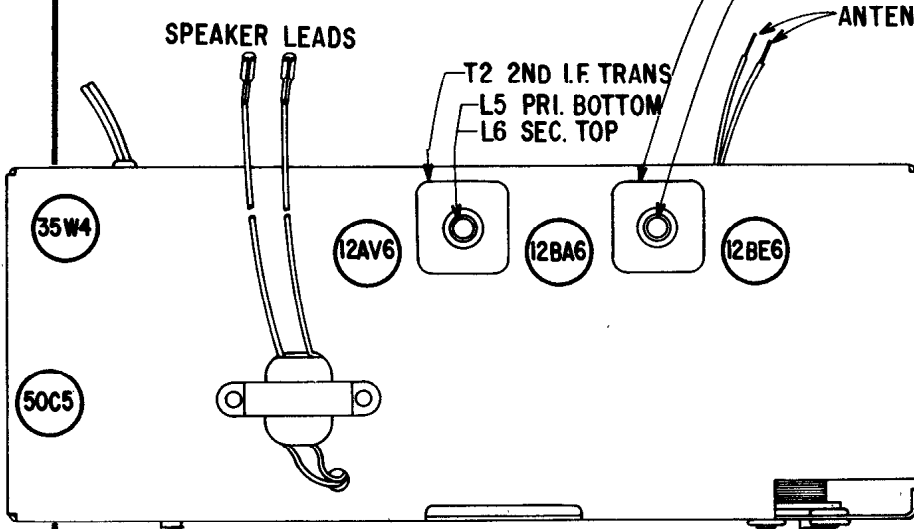

ALIGNMENT PROCEDURE

Operation	Connect Oscillator To	Dummy Antenna	Input Sig. Frequency	Set Dial At	Trimmers	Purpose
1	Converter Grid	.5 Mfd.	455 Kc.	600 Kc.	L3, L4, L5, L6	For I.F. Alignment.
2	One Turn Loop Coupled	—	1600 Kc.	1600 Kc.	C1D	Set Oscillator to Dial Scale
3	Loosely to Wave Magnet	—	1400 Kc.	1400 Kc.	C1B	Align Antenna Stage

VOLUME R-21, MOST-OFTEN-NEEDED 1961 RADIO SERVICING INFORMATION

ZENITH RADIO Chassis 5G09, Models G516C, L, V, W

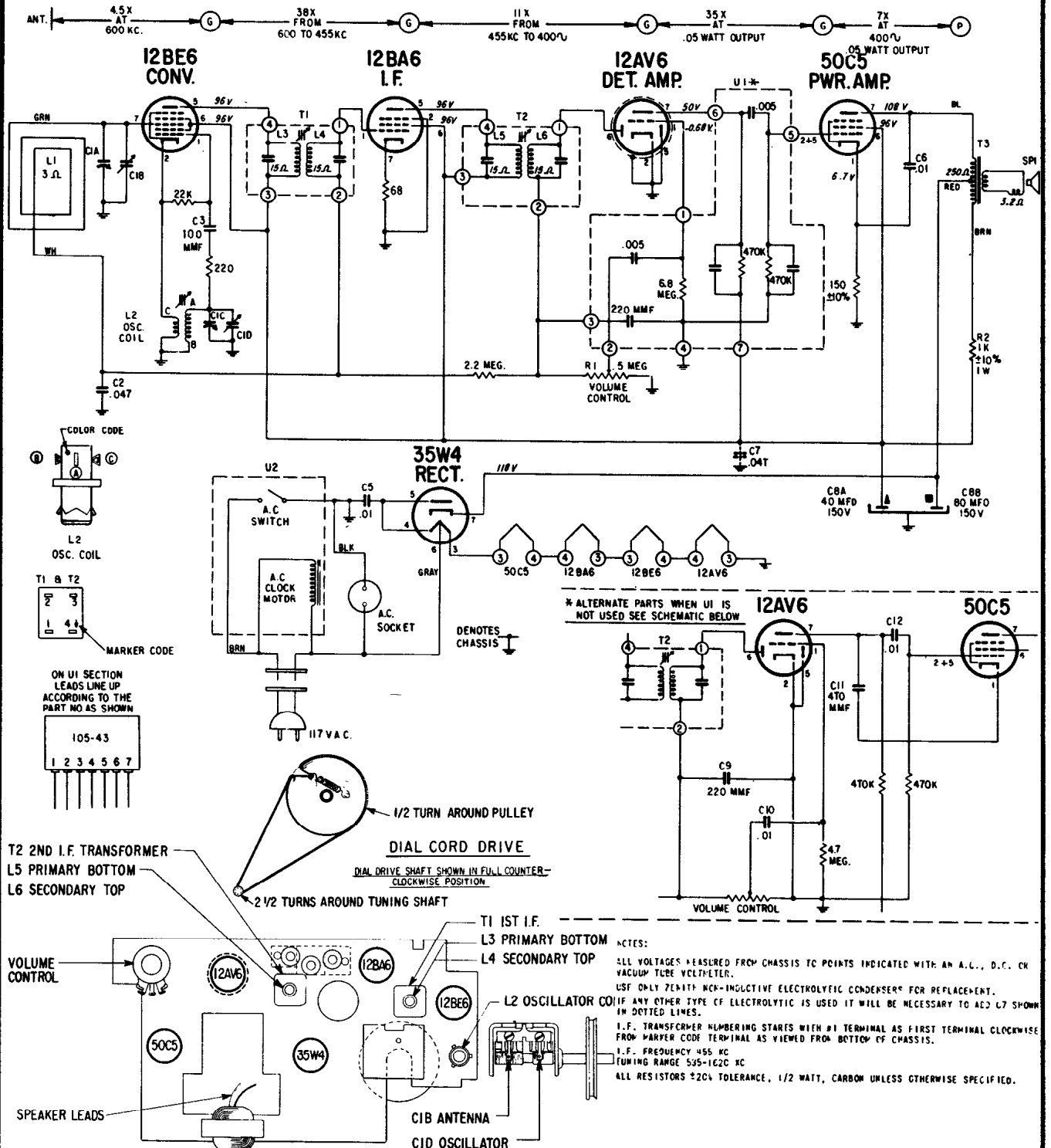

Alignment Procedure

OPERATION	CONNECT OSCILLATOR TO	DUMMY ANTENNA	INPUT SIG. FREQUENCY	SET DIAL AT	TRIMMERS	PURPOSE
1	Converter Grid	.05 Mfd.	455 Kc.	600 Kc.	L3, 4, 5, 6	For I.F. Alignment.
2	One Turn Loop Coupled Loosely to Wave Magnet	—	1600 Kc.	1600 Kc.	CID	Set Oscillator to Dial Scale
3		—	1400 Kc.	1400 Kc.	C1B	Align Antenna Stage

ZENITH RADIO MODEL D720C,P CHASSIS 6D01

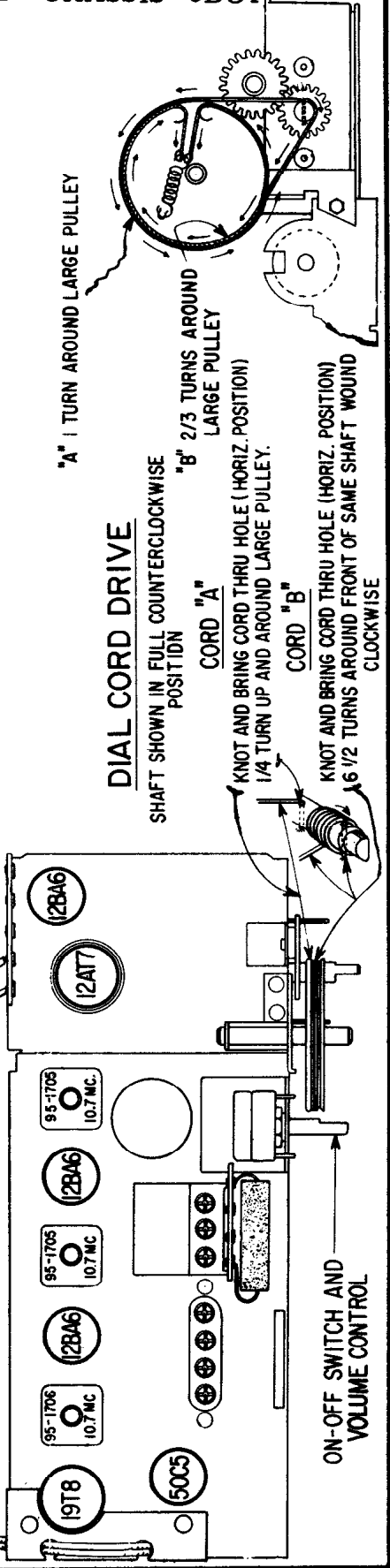
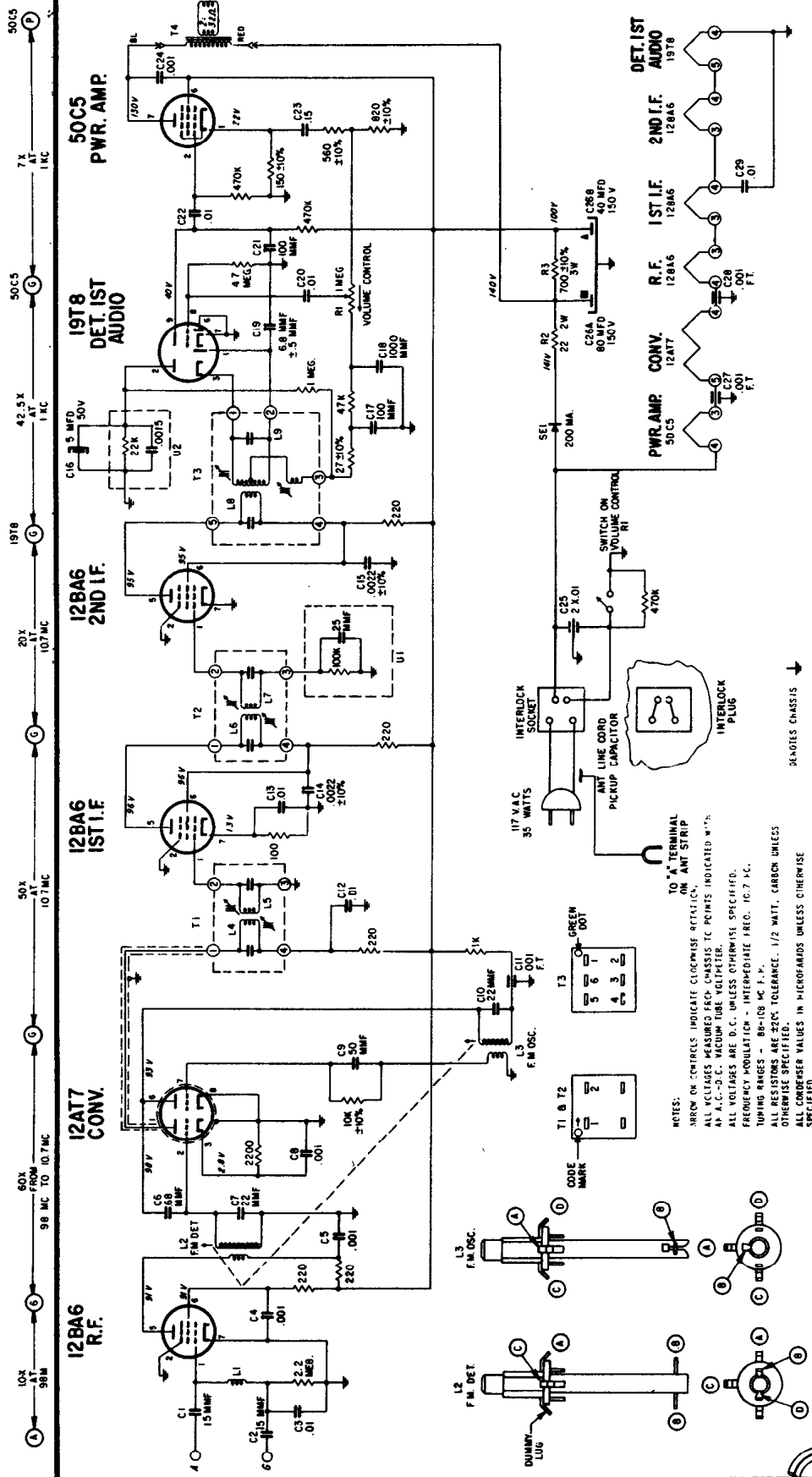

ZENITH MODEL F728C, L & W, CHASSIS 7F03

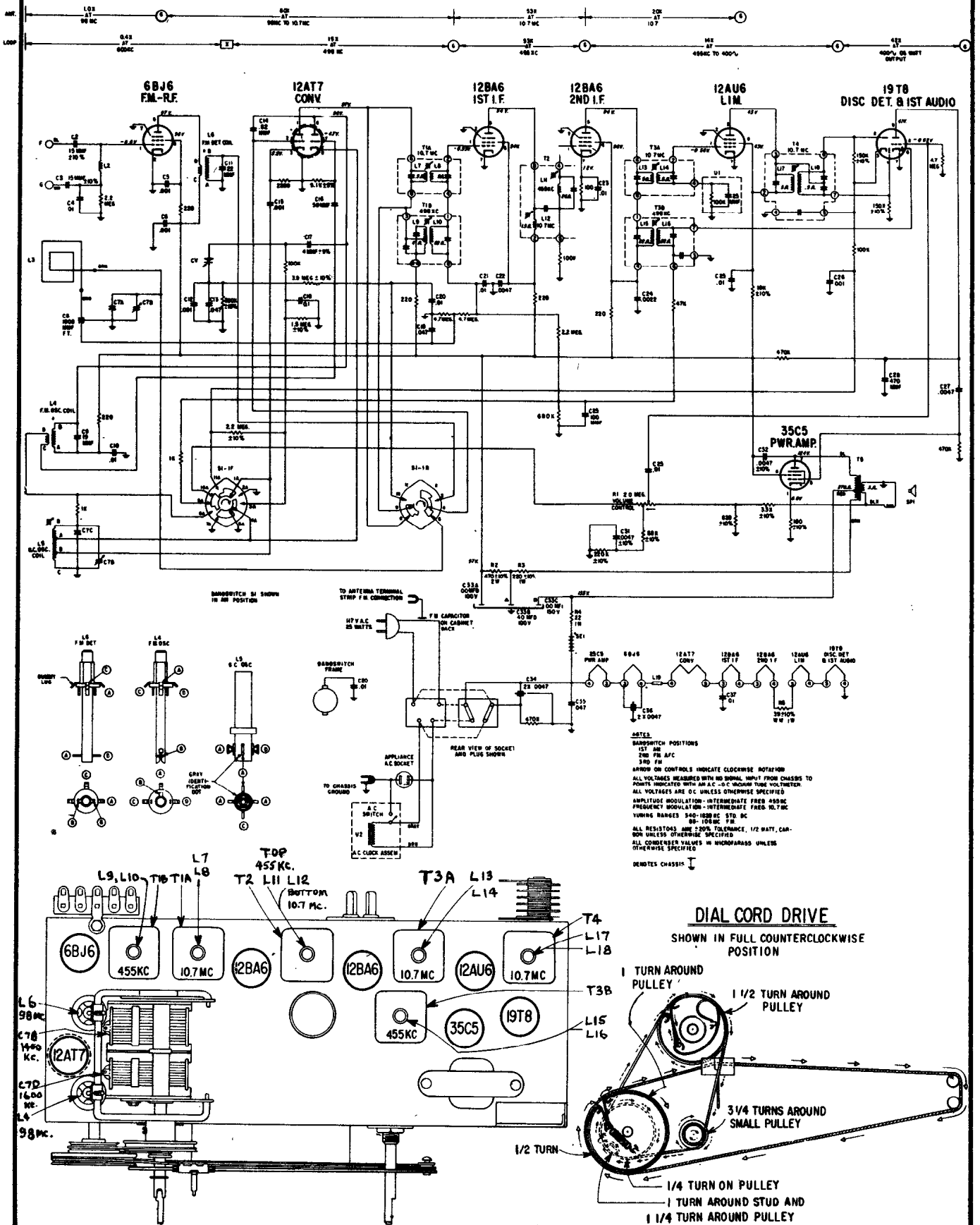

ZENITH RADIO Chassis 7FT45Z1, Model "Royal 475"

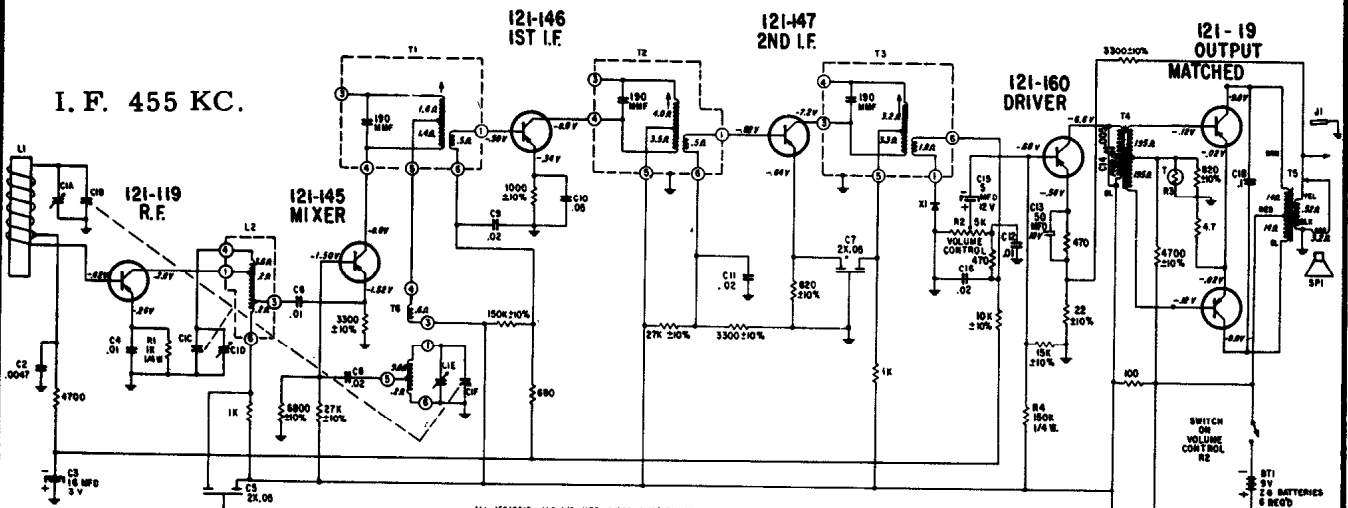

ALL RESISTORS ARE 1/2 WATT, CARBON 5% TOLERANCE UNLESS OTHERWISE SPECIFIED.
 ALL VOLTAGES ARE D.C. UNLESS OTHERWISE SPECIFIED.
 ALL CAPACITORS ARE IN MICROFARADS UNLESS OTHERWISE SPECIFIED.
 D.C. VOLTAGES SHOWN ARE MEASURED FROM CHASSIS WITH NO SIGNAL PRESENT USING
 A 50- μ C OR μ C/VOLTS TUBE VOLTMETER.

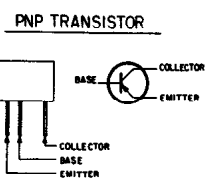
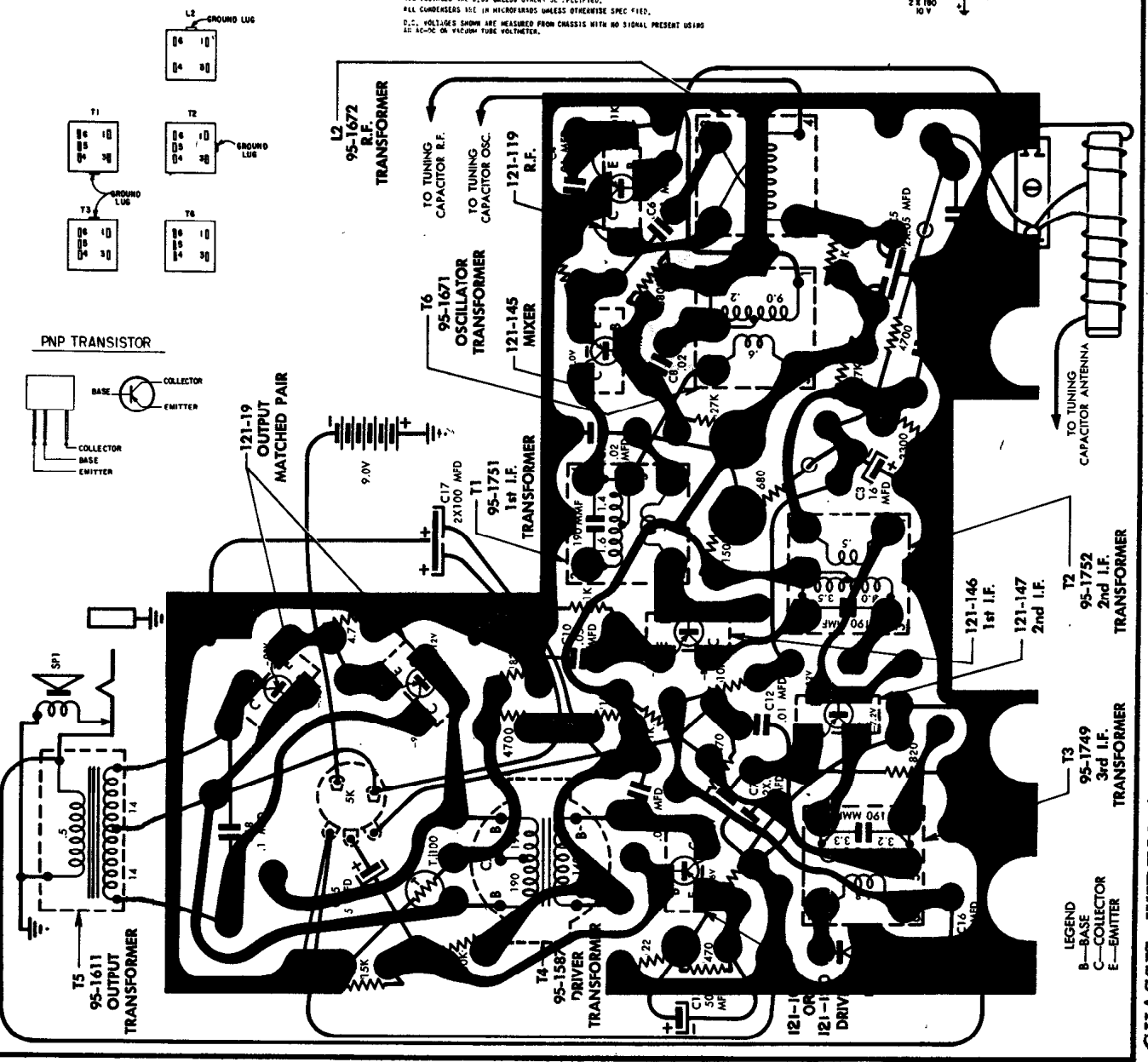

LEGEND
 B—BASE
 C—COLLECTOR
 E—EMITTER

CHASSIS, WIRING AND COMPONENTS VIEWED FROM WIRING SIDE

ZENITH Chassis 6GT40Z1 & 6GT40Z2, Model "Royal 50"
(Additional service material on page 187)

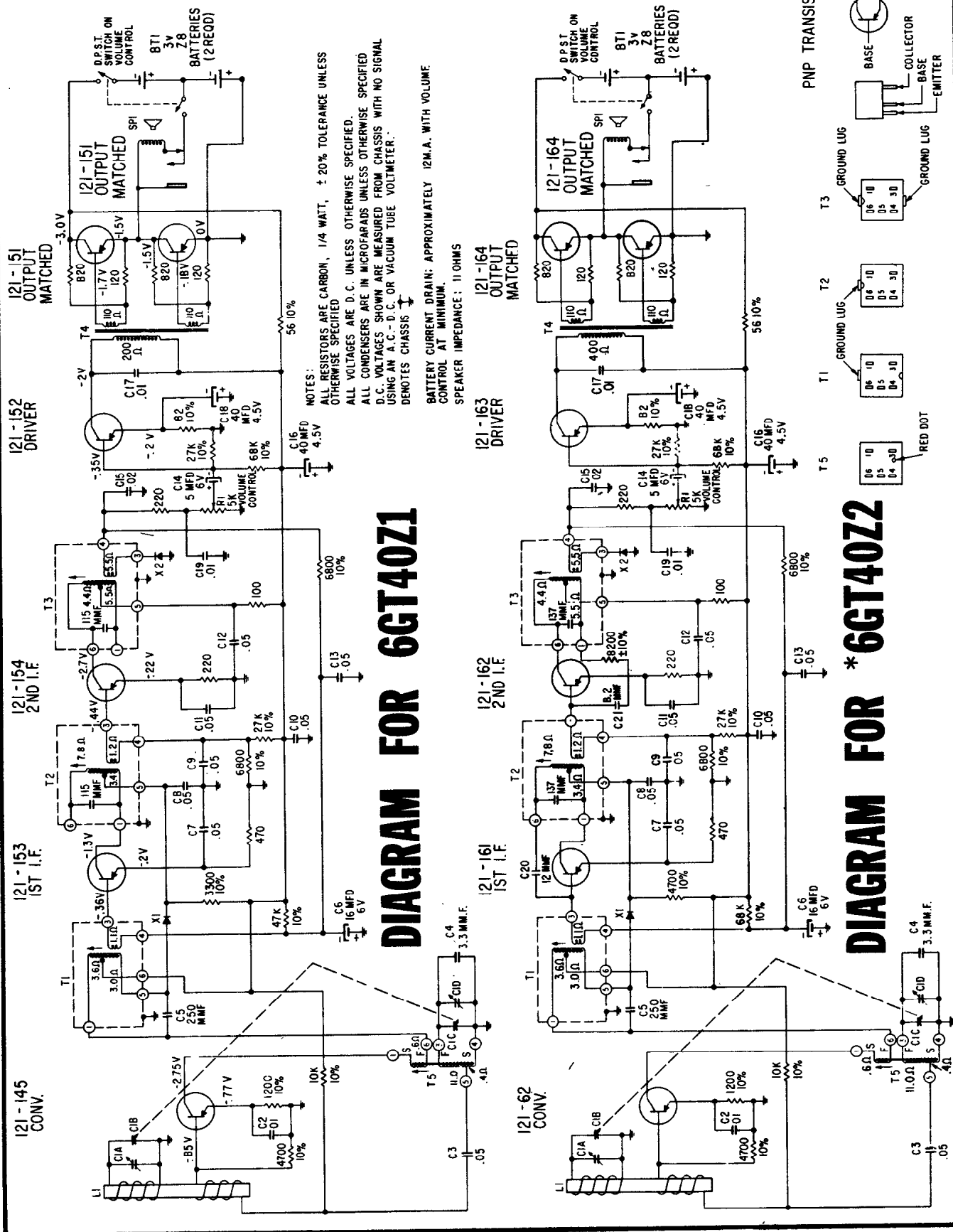

ZENITH Chassis 6GT40Z1 & 6GT40Z2, Model "Royal 50" Continued

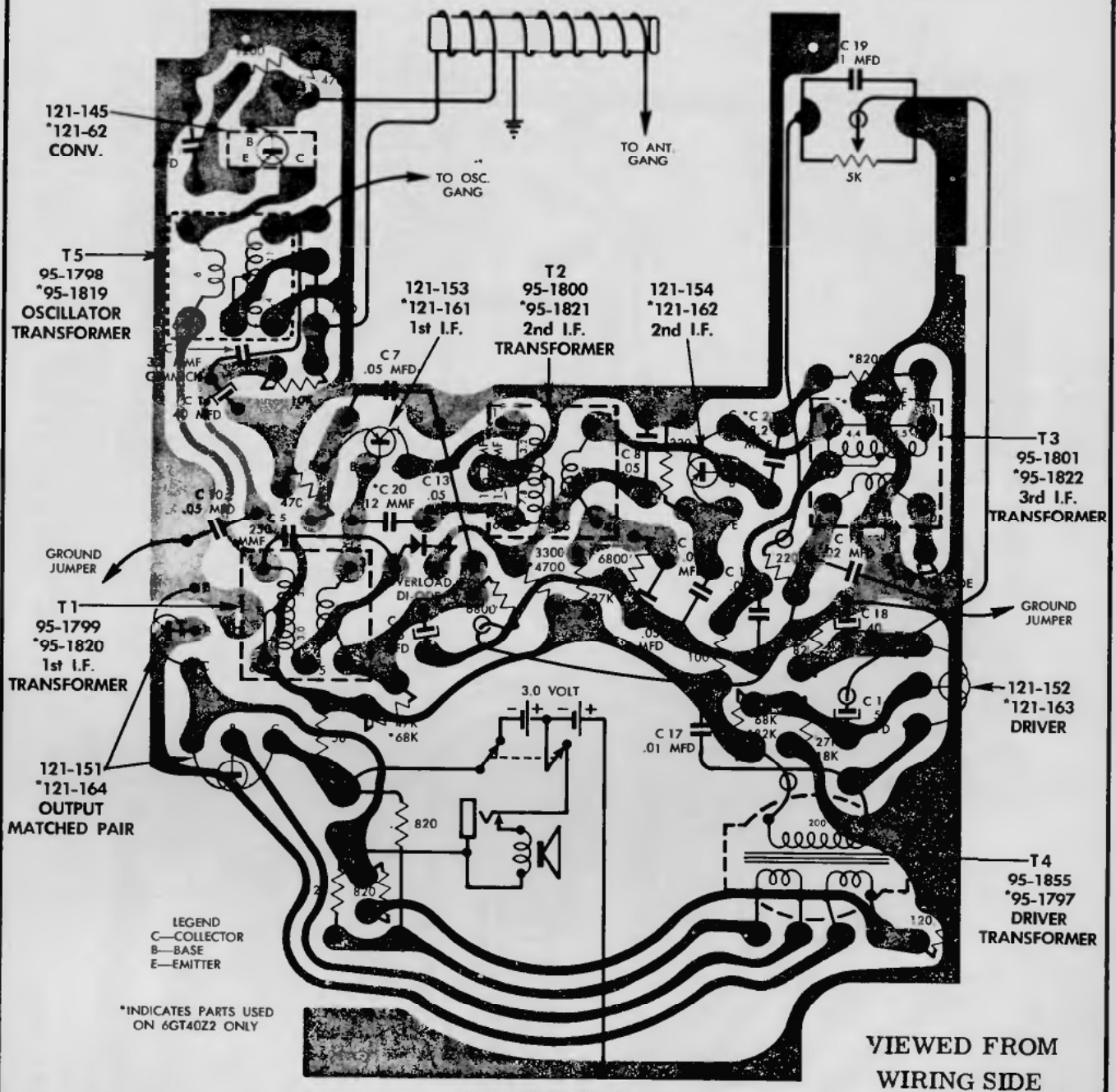

ALIGNMENT PROCEDURE

Operation	Input Signal Frequency	Connect Inner Conductor From Oscillator To	Connect Outer Shield Conductor From Oscillator To	Set Dial At	Trimmers	Purpose
1	455 KC	ONE TURN LOOSELY COUPLED TO WAVEMAGNET	Chassis	600 KC	Adj. T1, T2, T3 for maximum output.	For I.F. Alignment
2	1620 KC		—	Gang wide open.	C1D	Set Oscillator to dial scale.
3	600 KC		—	Near 600 KC	Adjust slug in T5	While rocking gang, adjust T5 for maximum output regardless of dial accuracy.
4	REPEAT STEPS 2 & 3		—	—	—	—
5	1260 KC		—	1260 KC	C1A	Align loop ant.

DIAGRAM FOR 6ET42Z2

VOLUME R-21, MOST-OFTEN-NEEDED 1961 RADIO

ZENITH Chassis 6ET42Z1 & 6ET42Z2, Model "Royal 100"
(Continued on page 189)

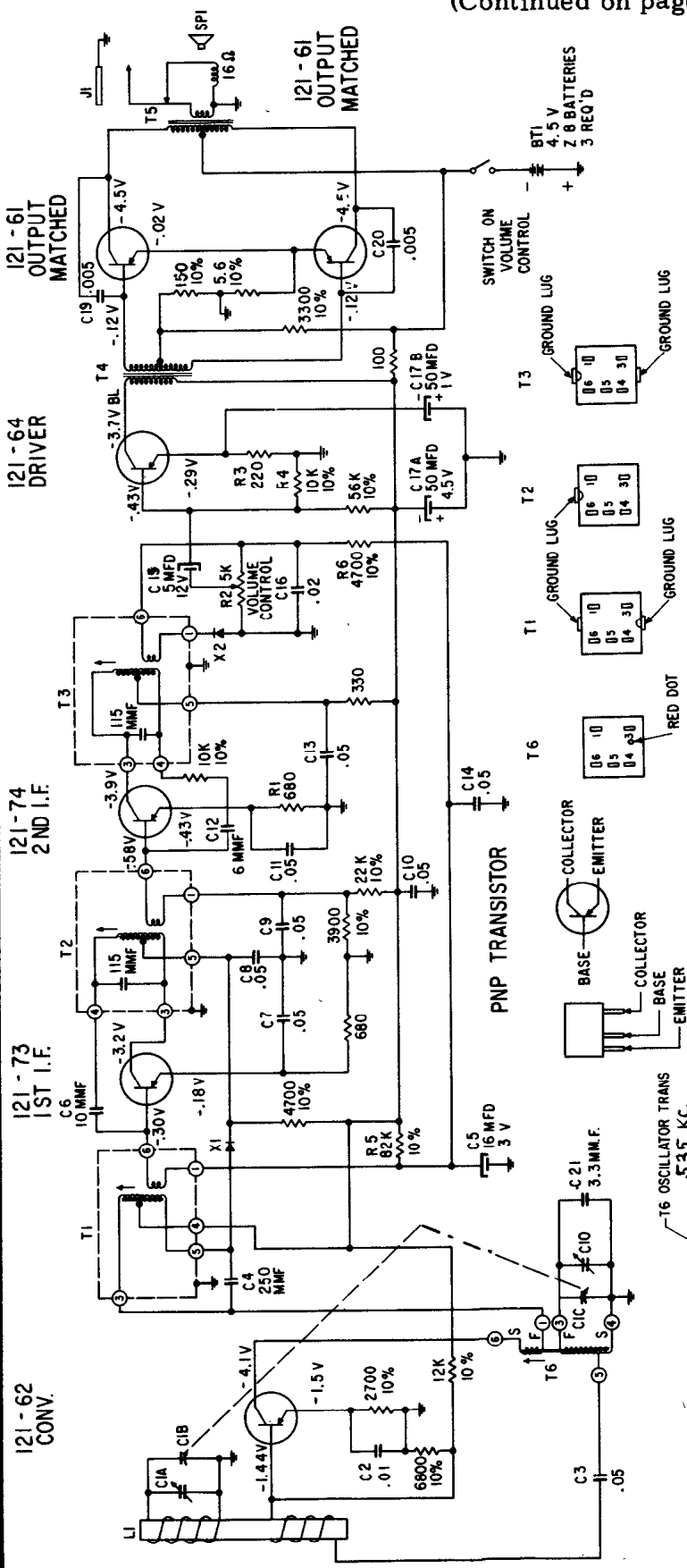

These transistor portable chassis are conventional superheterodyne receivers. Chassis 6ET42Z2 & 6ET42Z1 are virtually identical except for different transistors and a few other parts. The parts marked by asterisks on the chassis wiring and component drawing apply only to chassis 6ET42Z1. Both chassis have a converter to produce the 455 Kc intermediate frequency.

CHASSIS INFORMATION CHART

Chassis	Transistor Layout Label Color	Part No.	Conv.	1st I.F.	2nd I.F.	Crystal Diode Detector	Driver	Output-Output	Supplier
*6ET42Z1	Red 102-7651	Zenith RETMA Type	121-145 2N1108 PNP	121-146 2N1110 PNP	121-147 2N1111 PNP	103-19 1N87G	121-52 R120 PNP	121-19 R16 Matched Pair PNP	Texas Instrument
6ET42Z2	102-7302	Zenith RETMA Type	121-62 2N411 PNP	121-73 2N409 PNP	121-74 2N409 PNP	103-19 1N87G	121-64 2N407 PNP	121-61 2N407 Matched Pair PNP	R.C.A.

NOTES:
ALL RESISTORS ARE CARBON, 1/2 WATT, ±20% TOLERANCE UNLESS OTHERWISE SPECIFIED.
ALL VOLTAGES ARE D.C. UNLESS OTHERWISE SPECIFIED.
ALL CONDENSERS ARE IN MICROFARADS UNLESS OTHERWISE SPECIFIED.
D.C. VOLTAGES SHOWN ARE MEASURED FROM CHASSIS WITH NO SIGNAL USING AN A.C.-D.C. OR VACUUM TUBE VOLTMETER.
RED DOT DENOTES CHASSIS

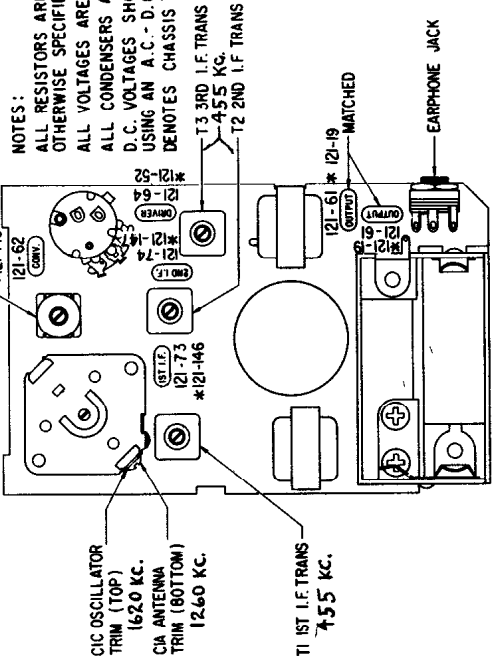

TRANSISTOR & TRIMMER LAYOUT FOR CHASSIS 6ET42Z2 & 6ET42Z1

VOLUME R-21, MOST-OFTEN-NEEDED 1961 RADIO SERVICING INFORMATION

ZENITH Chassis 6ET42Z1 & 6ET42Z2, Model "Royal 100" Continued

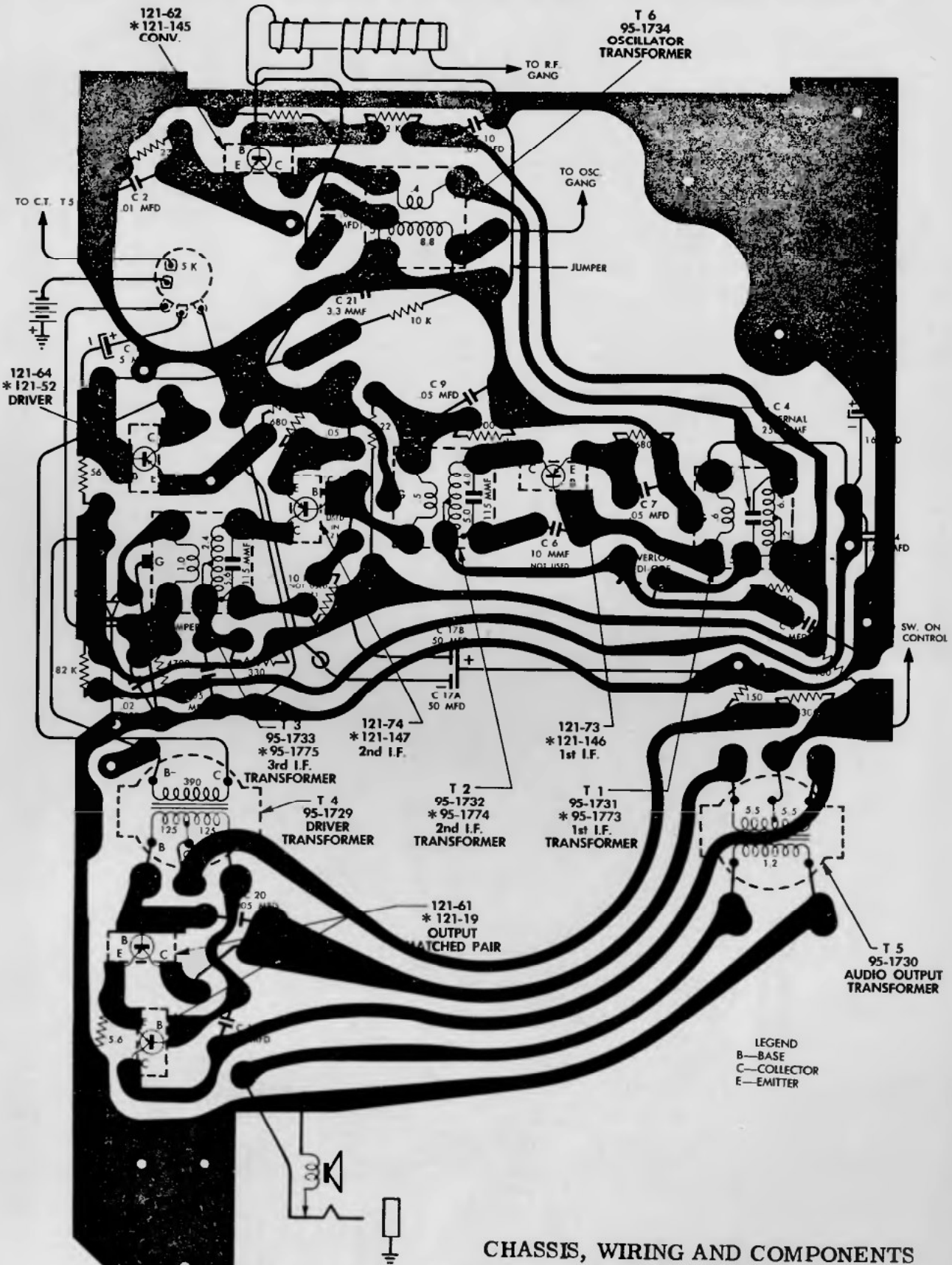

CHASSIS, WIRING AND COMPONENTS
VIEWED FROM WIRING SIDE

VOLUME R-21, MOST-OFTEN-NEEDED 1961 RADIO SERVICING INFORMATION

ZENITH Chassis 5F29, Models SFF2503T, SFF2505T, SFF2603, etc.,

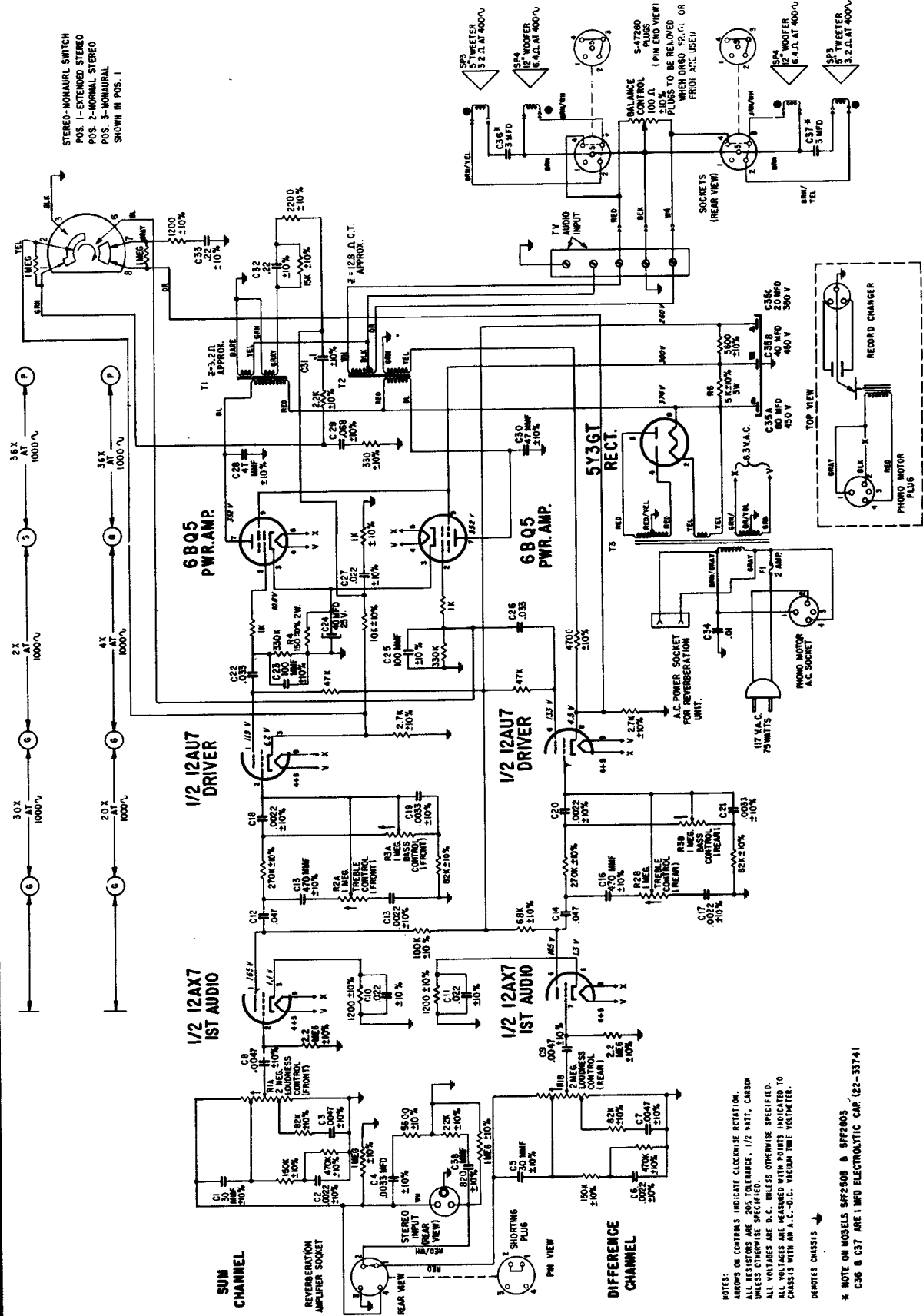

5F29 Schematic For Models SFF2503T, SFF2603, SFF2505T, SFF2605, SFF2606 & SFF2607



Index

Admiral Corp.	Admiral, Cont.	Chevrolet +	Gamble-Skogmo	Motorola, Cont.	Motorola, Cont.
3N1A 3	Y4072 3	988414 34	RA 48-8182A 46	A11A 97	109 80
4E3A 4	Y4073 3	988460 26	RA 50-8231 47	A11W 97	111 80
4F3A 5	Y4081 5	988468 35	RA 50-8232 47	C10N 95	113 80
4L2B 6	Y4082 5	<u>Coronado</u>		C10P 95	114 80
4L26B 6	Y4083 5	RA 48-8182A 46	<u>General</u>	C10W 95	309 80
4L27B 6	Y4131 9	RA 50-8231 47	<u>Electric</u>	C11B 95	310X 82
4L28B 6	Y4132 9	RA 50-8232 47	T100A 48	C11G 95	311 80
4L29B 6	Y4159 9	<u>Delco</u>	T145A 49	C11S 95	311X 83
4N3 4		AC-2977 26	T146A 49	A12N 104	314L,V 80
4P3, -A 7	<u>American</u>	AC-2978 27	T150B 50	C12B 96	500X 79
5B5B 8	<u>Motors</u>	AC-3084 26	T151B 50	C12P 96	HS-746 85
5B5C 8	8990831 67	AC-3085 27	T165A 51	C12W 96	HS-775 86
5K5A 9	8990832 66	AC-3086 26	T166A 51	13MA 66	HS-776 86
5K5B 9	8990833 70	AC-3087 27	T210B 52	13MAM 67	HS-778 86
5M5 10		980051 28	C403A 48	14MF 68	HS-795 88
5R5 11	<u>Arvin</u>	980052 29	P790A, B 53	14MFM 68	HS-796 89
5S5 12	5R65 22	980132 31	P791A, B 53	14MR 70	HS-797 90
6T5 13	5R67 22	980134 32	P805A 54	X14B 88	HS-798 91
5V5 14	10R16 19	980135 29	P806A 54	X14E 88	HS-799 92
7A2 16	10R18 19	988062 26	P807A 54	X14R 88	HS-800 93
7D2 17	10R32 20	988275 26	P807B 55	X14W 88	HS-802 94
8D2 18	10R38 20	988276 30	P808A 54	SF15, -1 110	HS-813 95
Y853C 8	10R39 20	988413 33	P808B 55	SF15-2 110	HS-814 95
Y865B 8	30R12 21	988414 34	P815A 56	X15A 89	HS-815 96
Y866B 8	30R18 21	988460 26	P816A 56	X15E 89	HS-819 98
Y979 9	60R23 23	988468 35	P830C 57	X15N 89	HS-820 100
Y1002 9	60R28 23	989387 31	P830E 58	X16B 90	HS-821 102
Y1009 9	60R29 23	989392 36	P831C 57	X16G 90	HS-824 97
Y1021 9	60R47 23	989693 37	P831E 58	X16N 90	HS-825 104
Y1022 9	60R49 23	989792 26	RP1100A 59	X17B 91	HS-827 105
Y1023 9	60R58 24	<u>Emerson Radio</u>	RP1112A 60	X17N 91	HS-828 105
Y1189A 4	60R63 24	907B 39	RP1127A 59	X17R 91	HS-829 106
Y2061 16	60R69 24	914B 44	RP1128A 59	XT18B 94	HS-830 106
Y2063 16	60R73 24	920 40		XT18S 94	HS-831 107
Y2067 16	60R79 24	925 40	<u>Hitachi, Ltd.</u>	SH19 111	HS-832 107
Y2068 16	90P53 25	926B 39	TH-627R 61	X19A 92	HS-833 108
Y2119 17	90P58 25	933B 41		X19E 92	HS-835 109
Y2127 18	1.42202 19	935B 41	<u>Magnavox</u>	L20E 93	HS-860 110
Y2993 7	1.47001 22	937B 41	65-01 62	SH20 105	HS-861 111
Y2996 7	1.48101 21	938B 42		SH21 106	HS-869 111
Y2998 7	1.48102 21	944B 44	<u>Montgomery</u>	X21W 112	HS-876 112
Y2999 7	1.49201 23	977 43	<u>Ward</u>	SH22 107	HS-898 110
Y3021 11	1.49501 25	120478B 39	GEN-1667A 64	SK32W 86	FM-900 84
Y3027 11	1.49801 20	120482B 44	GEN-1668A 64	SK33W 86	1500 94
Y3037 4	1.50101 24	120483B 44	GEN-2030A 63	SK35W 86	<u>Oldsmobile</u>
Y3037A 7	1.50300 24	120494B 40	GEN-2030B 63	SK39MB 86	989387 31
Y3038 4	1.50401 23	120505B 39		SK40, -1 108	989392 36
Y3046 12		120522B 44	<u>Motorola, Inc.</u>	SK41 108	
Y3048 12	<u>Buick</u>	120523B 44	BJJ 98	SK43, -1 109	<u>Packard-Bell</u>
Y3049 12	980051 28	120528 43	BLW 98	BKA 60X 72	5R8 113
Y3051 13	980052 29	120547B 41	B2G 100	CRA 60X 73	5RC8 113
Y3053 13	980132 31	120548B 41	B2N 100	CRM 60X 75	
Y3058 13	980134 32	120558B 41	B2W 100	OEA 60X 76	
Y3083 14	980135 29	120559B 42	A3B, N 85	PCA 60X 72	<u>Philco Corp.</u>
Y4017 10	<u>Chevrolet</u>		B3E 102	VWA 60 74	T-50(126) 114
Y4049 3	988062 26	<u>Ford</u>	B3W 102	BKA 61 77	T-51(124) 114
Y4057 5	988275 26	COAF-18805D 68	O4MD 68	CTA 61 77	T-52(124) 115
Y4067 9	988276 30	CLAF-18805+ 68	10AX 65	CTM61X 78	TC-57 115
Y4071 3	988413 33			CTM61XA 78	T-62 116

(Index continued on page 192, over)

VOLUME R-21, MOST-OFTEN-NEEDED 1961 RADIO SERVICING INFORMATION

Philco, Cont.		RCA, Cont.		Sylvania, Cont.		Webcor, Inc.		Westinghouse+	
T-66	117	DK-111	139	8F16	148	14X310-1	159	H-F1011A	171
T-70	118	RS-171D	140	8P18	151	14X331	160	H-F1012A	171
T-74	119	RS-171F	140	45C13	146	1050-1A	159	H-F1013A	171
T-76	120	RS-175B	138	45C14	146	BC1055	160	H-F1050B	171
J-769	121	RS-177A	140	45P19	156	MC1055	160	H-F1051B	171
J-772	121	RS-179	140	630-5,-6	143	WC1055	160	H-F1052B	171
J-773	121	RS-182A	137	630-7,-8	143	1172-1	159	H-F1053B	171
J-774	121	RS-187	139	631-2,-3	144			V-2395-2	163
J-775	121	RS-188	136	632-3	145	<u>Western Auto</u>		V-2395-3	163
T-802	124	VC-270	136	649-1,-2	147	DC2082B	161	V-2397-4	166
J-838	121	VC-271	136	651-1,-2	143	DC2083B	161	V-2399-1	164
J-840	121	VC-272	136	651-3,-4	143	DC2172A	161	V-2401-3	167
J-842	121	VC-273	136	652-1	148	DC2173A	161	V-2404-1	168
J-845	121	RC-1192	140	653-1	148	DC3085C	162	V-2410-1	169
J-846	121	RC-1199	132	661-1	149	DC3160	162	V-2410-2	170
T-901	125	RC-1199A	132	668-1,-2	150			V-2506-5	177
J-996	126	RC-1199B	133	673-1	151	<u>Westinghouse</u>		V-2507-4	176
J-997	127	RC-1200	130	676-1	152	H-61MP2	172	V-2507-5	175
J-1423	128	RC-1200A	130	677-1	153	H-61MP3	172	V-2507-6	174
J-1425	128	RC-1201A	129	678-1	154	H-63AC1	176	V-2507-8	173
J-1525	128	RC-1202A	134	679-1	155	H-63AC2	176	V-2508-3	172
J-1626	128	RC-1202B	134	680-1	156	H-64ACS1	172	V-2508-5	176
		RC-1202C	134	690-1	157	H-64ACS2	172	V-2508-6	172
				1100	143	H-65ACS1	177	V-2508-7	172
<u>Pontiac</u>		<u>Studebaker</u>		1111	143	H-65ACS2	177	V-2512-3	171
989693	37	AC-2977	26	1160	143	H-66ACS1	176		
989792	26	AC-2978	27	1212	143	H-66ACS2	176	<u>Zenith Radio</u>	
		AC-3084	26	1219	143	H-67ACS1	175	5D12	181
<u>RCA Victor</u>		AC-3085	27	1286	143	H-67ACS2	175	5D20	178
1F1	129	AC-3086	26	1300	143	H-68ACS1	174	5F03	179
1F2	129	AC-3087	27	1301	143	H-68ACS2	174	5F04	179
1T1	130			1306	143	H-70ACS1	173	5F13	180
1T2	130	<u>Sylvania Elec.</u>		1309	143	H-70ACS3	173	5F29	190
1T3	130	1-647-1	146	1322	143	H-70ACS4	173	5G09	182
1TC4	130	4C09	150	1400	143	H-712P9	164	6D01	183
1TP1	132	4C15	150	1512	143	H-713P9	164	6ET42Z1	188
1TP2	132	4P05	157	1519	143	H-718T5A	167	6ET42Z2	188
LX2	134	4P06	157	1600	143	H-719T5A	167	6GT40Z1	186
LX3	134	4P14	149	1701	143	H-720T5A	167	6GT40Z2	186
LX4	134	4P15	149	1704	143	H-725P6A	166	7F03	184
BK-1	139	4T09	150	1708	143	H-726P6A	166	7FT45Z1	185
TPM-11	140	4T15	150	1709	143	H-727P6A	166	50	186
TPM-12	140	5C10B,P	143	2300	147	H-728P6A	166	XD50C,+	181
TPM-13	140	5C11B,T	143	2400	147	H-737P7	168	XD60C,+	179
VC-13	140	5C12R,T,W	143	2500	147	H-738P7	168	100	188
VCR-13	140	5C13	144	2600	147	H-748T5	163	475	185
VC-14	140	5P16	147	2700	147	H-749T5	163	E512C,+	180
VCR-14	140	5T10B,P	143			H-750T5	163	E514B,+	179
VC-16	140	5T11B,T	143	<u>Trav-ler</u>		H-753L5	163	G516C,+	182
PM-17	140	5T12R,T,W	143	60C300	158	H-755L5	163	SFD660	178
VC-17	140	5T13	144	60C301	158	H-756T5	169	D720C,P	183
PM-18	140	5T17	152	60C302	158	H-757T5	169	F728C,+	184
VC-22	140	6F17	153	60C303	158	H-759T6	170	SFF2503T	190
VP-33	136	6F18	154	60C320	158	H-760T6	170	SFF2505T	190
RS-34P	135	6T14	145	60C321	158	H-771P6,+	166	SFF2603	190
VP-34	135	7K10	155	60C322	158	H-772P6,+	166	SFF2605	190
VP-36	137	7K11	155	60C323	158	H-773P6,+	166	SFF2606	190
DK-109	139	8F15	148	1130	158	H-F1010A	171	SFF2607	190
DK-110	139								